

Overlap Cladding

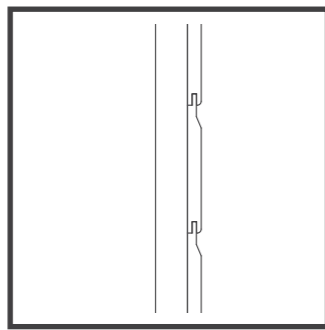

Shiplap Cladding

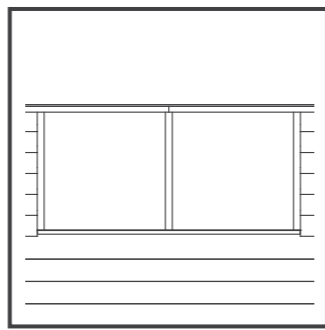

Fixed Windows

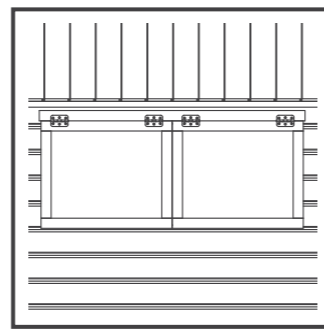

Opening Windows

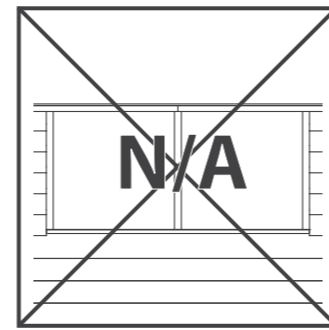

No Windows

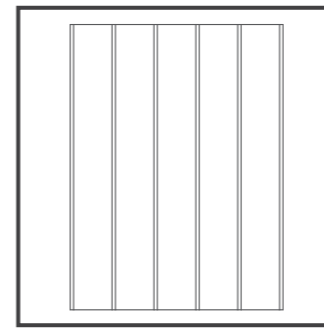

Solid Sheet Floor

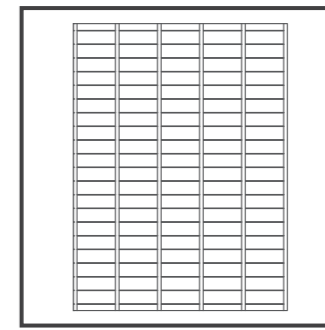

T&G Floor

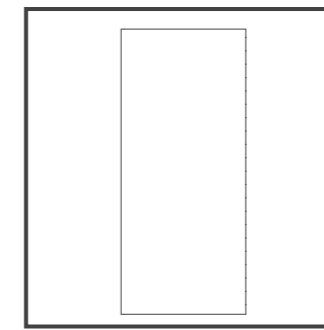

Solid Sheet Roof

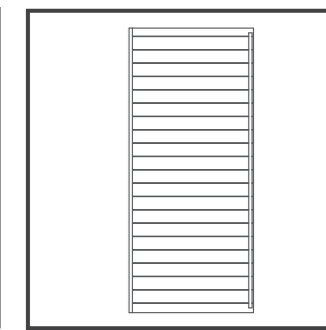

T&G Roof

01OVLPA1010DDFW-V1

10x10 Overlap apex shed with double doors, fixed windows, solid sheet floor and roof.

01OVLPA1010DDFW-V1-NW

10x10 Overlap apex shed with double doors, no windows, solid sheet floor and roof.

01OSBA1010DDFW-V1

10x10 Shiplap apex shed with double doors, fixed windows, solid sheet floor and roof.

01OSBA1010DDFW-V1-NW

10x10 Shiplap apex shed with double doors, no windows, solid sheet floor and roof.

01SHPA1010DDOW-V1

10x10 Shiplap apex shed with double doors, opening windows, T&G floor and roof.

01SHPA1010DDOW-V1-NW

10x10 Shiplap apex shed with double doors, no windows, T&G floor and roof.

BEFORE YOU START PLEASE READ INSTRUCTIONS CAREFULLY

- Check the pack and make sure you have all the parts listed.
- When you are ready to start, make sure you have the right tools at hand (**not supplied**) including a Phillips screwdriver, Stanley knife, wood saw, step ladder and drill with 2mm bit.
- Ensure there is plenty of space and a clean dry area for assembly.

TIMBER

As with all natural materials, timber can be affected during various weather conditions. For the duration of heavy or extended periods of rain, swelling of the wood panels may occur. Warping of the wood may also occur during excessive dry spells due to an interior moisture loss. Unfortunately, these processes cannot be avoided but can be helped. It is suggested that the outdoor building is sprayed with water during extended periods of warm sunshine and sheltered as much as possible during rain or snow.

Our buildings are pre treated with a water based treatment**; this only helps to protect the product during transit and for upto 3 months against mould. To validate your guarantee and ensure longevity of the product, it is **ESSENTIAL** the building is treated with a wood preserver within the first three months of assembly and thereafter in accordance with the manufactures recommendations. Care must be taken to ensure the product is placed on a suitable base.

BUILDING A BASE

When thinking about where the building and base is going to be constructed: Ensure that there will be access to all sides for maintenance work and annual treatment.

Ensure the base is level and is built on firm ground, to prevent distortion. Refer to diagrams for the base dimensions, The base should be slightly smaller than the external measurement of the building, i.e. The cladding should overlap the base, creating a run off for water. It is also recommended that the floor be at least 25mm above the surrounding ground level to avoid flooding.

TYPES OF BASE

- Concrete 75mm laid on top of 75mm hard-core.
- Slabs laid on 50mm of sharp sand.

Whilst all products manufactured are made to the highest standards of Safety and in the case of childrens products independently tested to EN71 level, we cannot accept responsibility for your safety whilst erecting or using this product.



x2

All building's should be erected by two adults



2mm Drill bit

For ease of assembly, you must pilot drill all screw holes and ensure all screw heads are countersunk.



Winter = High Moisture = Expansion
Summer = Low Moisture = Contraction



CAUTION

Every effort has been made during the manufacturing process to eliminate the prospect of splinters on rough surfaces of the timber. You are strongly advised to wear gloves when working with or handling rough sawn timber.

For Assistance Please Contact Customer Care on 01636 880514

****Protim Fentex E5****

Biocidal Product Regulation (EU 528/2012) Article 58 Information
Protim Fentex E2 preserved wood is a "treated article" which incorporates biocidal products. Wood correctly preserved with Protim Fentex E2 is protected against mould in storage. Contains: IPBC (3-iodo-2-propynyl-N-butyl carbamate) and propiconazole.

Wear gloves when handling freshly treated wood.
Avoid breathing dust when cutting treated or untreated wood.
Dispose of off-cuts responsibly – do not burn.

01OVLPA1010DDFW-V1 & 01OVLPA1010DDNW-V1

Please retain product label and instructions for future reference

Overall Dimensions:

Length = 3028mm
Width = 3095mm
Height = 2257mm

Base Dimensions:

Length = 2974mm
Width = 2974mm

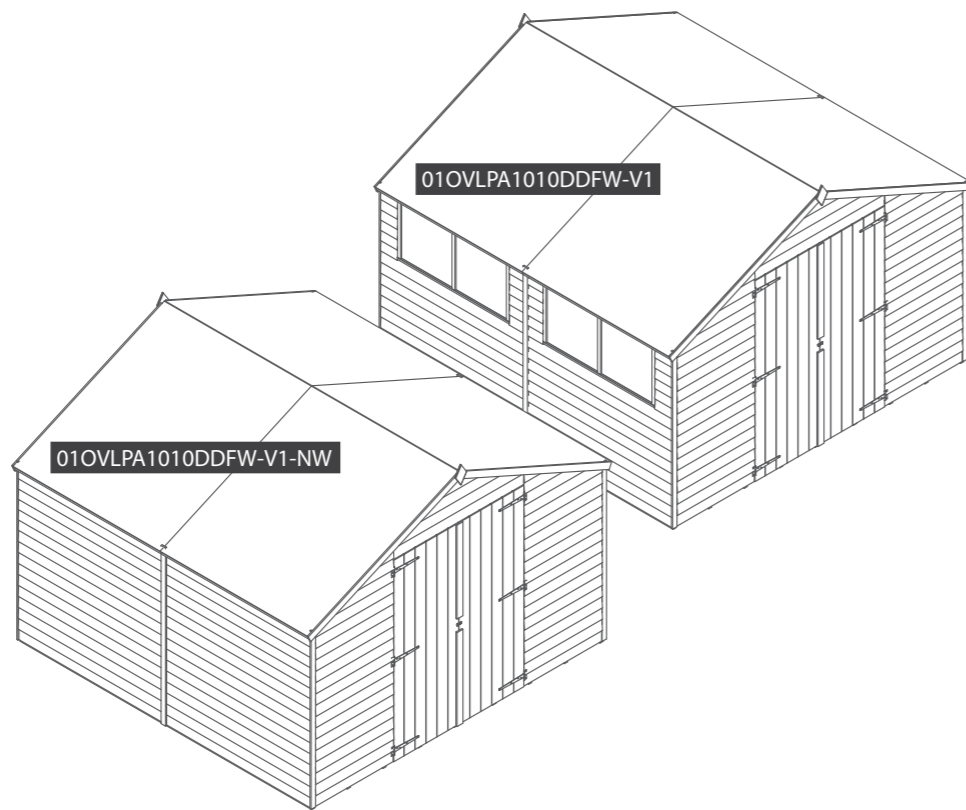

Before assembly please make sure you have a suitable base ready to erect your building

Building content

- | | | | | | | | | | |
|-------------------|------------------|-----------------|------------------|-----------------|----------------------------|-----------------------------|-------------|------------------|------------|
| 1 | 2 | 3 | 4 | 5 | 6 | 7 | 8 | 9 | 10 |
| | | | | | | | | | |
| Front Gable Right | Front Gable Left | Front Gable Top | Back Gable Right | Back Gable Left | Plain Side Qty 2 - NW Only | Window Side Qty 2 - FW Only | Floor Qty 4 | Roof Sheet Qty 4 | Door Qty 2 |
-
- | | | |
|----|--|---------------------------------------|
| 11 | | Truss |
| 12 | | Ridge Bar - 1462mm Qty 2 |
| 13 | | Truss Block - 140mm Qty 2 |
| 14 | | Floor Blocks - 400mm Qty 8 |
| 15 | | Door Gable Bottom Rail - 1332mm Qty 1 |
| 16 | | Door Block - 140mm Qty 2 |
| 17 | | Door Strip - 830mm Qty 2 |
| 18 | | Cover Trim - 1575mm Qty 6 |
| 19 | | Door Beading Strip - 1720mm Qty 2 |
| 20 | | Fascia - 1667mm Qty 4 |
| 21 | | Plain Gable Strip - 2164mm Qty 1 |
-
- | | | |
|----|--|---------------------------------------|
| 22 | | Door Gable Strip - 1875mm Qty 1 |
| 23 | | Eaves Frame - 1502mm Qty 4 |
| 24 | | Window Strip - 546mm Qty 10 - FW Only |
| 25 | | Finial Qty 2 |
| 26 | | T Hinge Qty 6 |
| 27 | | Plastic Window Cill Qty 2 - FW Only |
| 28 | | Turn Button Qty 3 |
| 29 | | Felt |
| 30 | | Styrene Qty 4 - FW Only |
| 31 | | L-Bracket Qty 2 |

Nail Bag

- | | | | |
|--|------------------|--|----------------------|
| | 30mm Screw x 147 | | Felt Tacks x 170 |
| | 40mm Screw x 130 | | 16mm Screws x 25 |
| | 50mm Screw x 60 | | 20mm Screw x 32 |
| | 70mm Screw x 7 | | 30mm Black Screw x 3 |
| | 100mm Screw x 3 | | |

Pre Assembly

Remove transportation blocks from the bottom of each panel before beginning assembly. Each Panel should have two

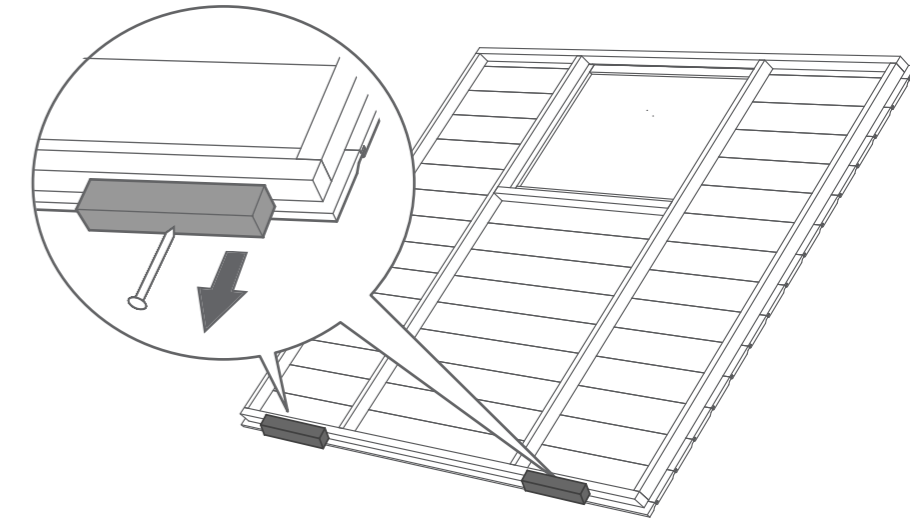

Step 1 Door Gable Assembly

Lay the Front Gable Right and Front Gable top on a level floor place them next to each other, ensure they are level at the top then fix together using 2x50mm screws. Stagger the screws so they do not collide.

2 x 50mm screws

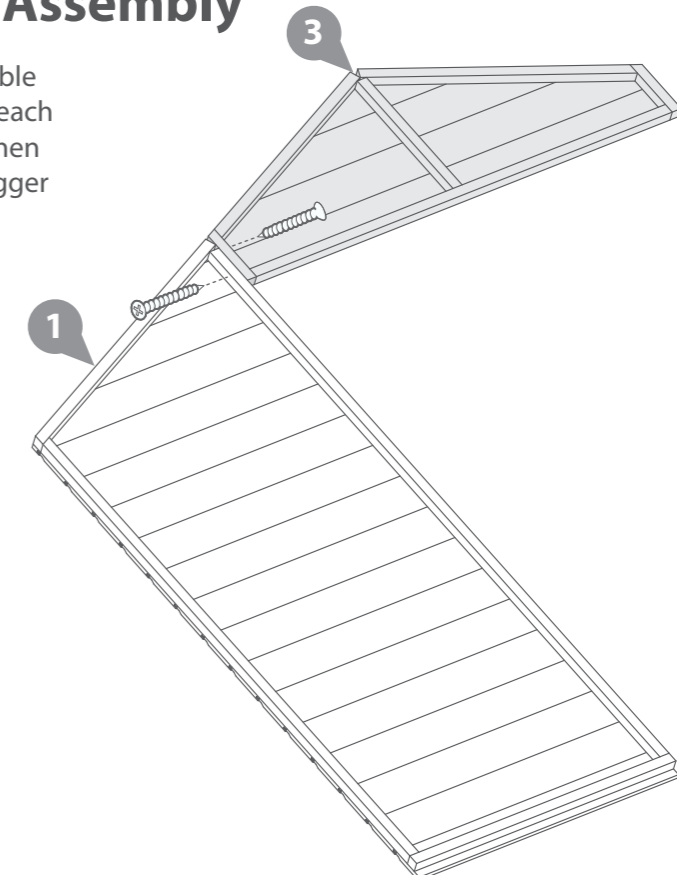

Step 2

Lay the Front Gable Left next to the Front Top Gable, ensure they are level at the top then fix together using 2x50mm screws. Stagger the screws so they do not collide.

2 x 50mm screws

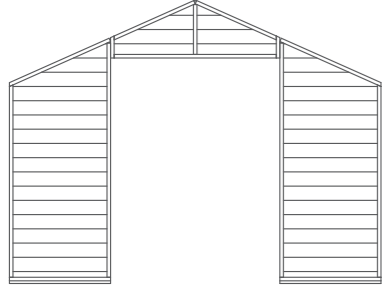
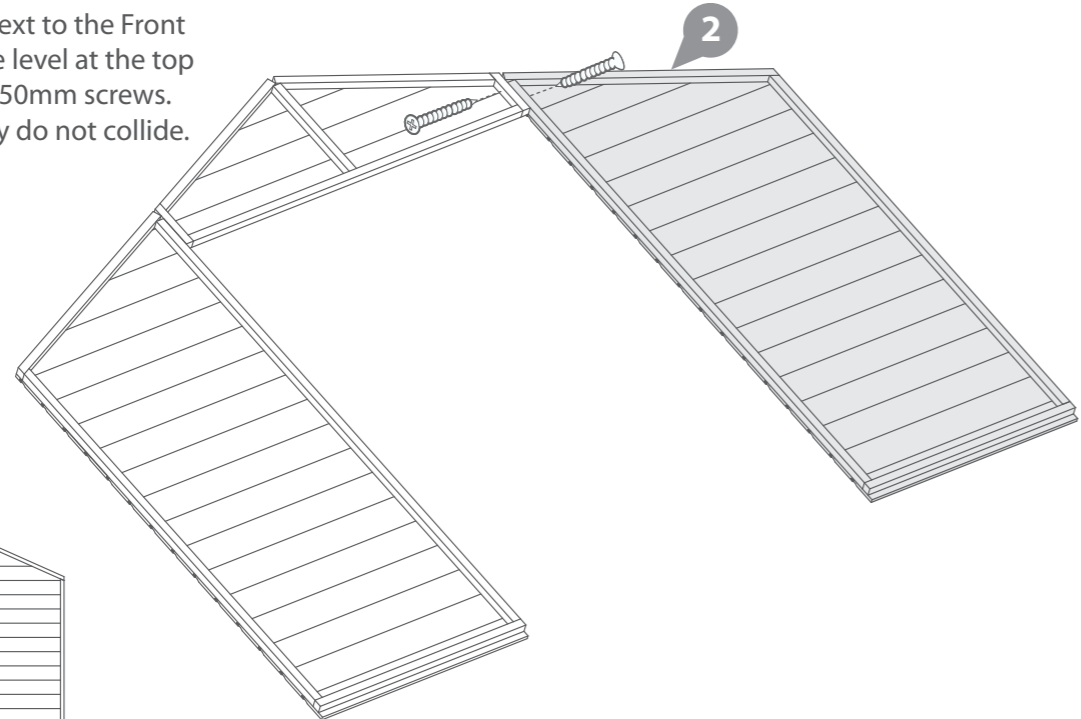
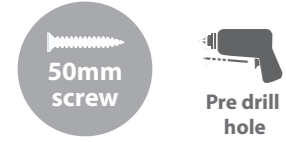

Line the Door Gable Strip up to the assembled gable at the corners as shown in the illustration and fix in place using 40mm screws

6 x 40mm screws

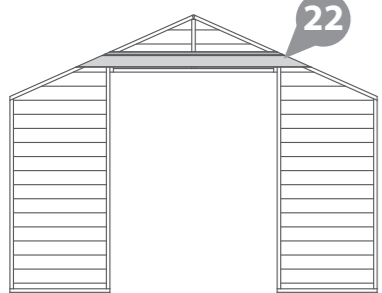
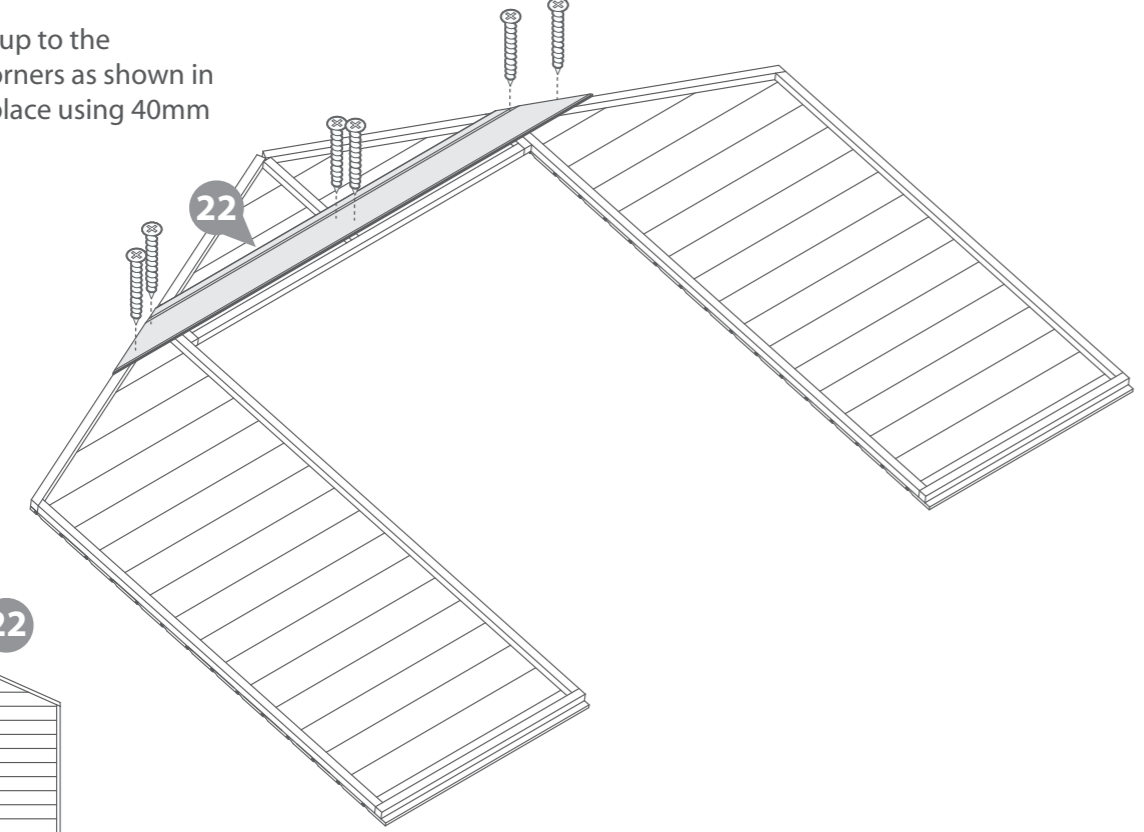

Step 3 Plain Gable Assembly

Lay the Back Left Gable and Back Right Gable on a level floor place them next to each other, ensure they are level at the top and bottom then fix together using 10x50mm screws. Stagger the screws so they do not collide.

10 x 50mm screws

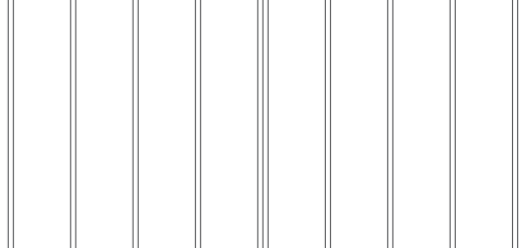
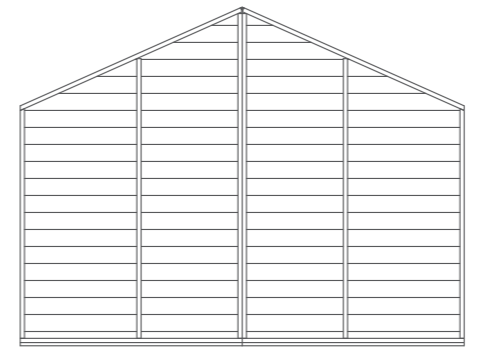
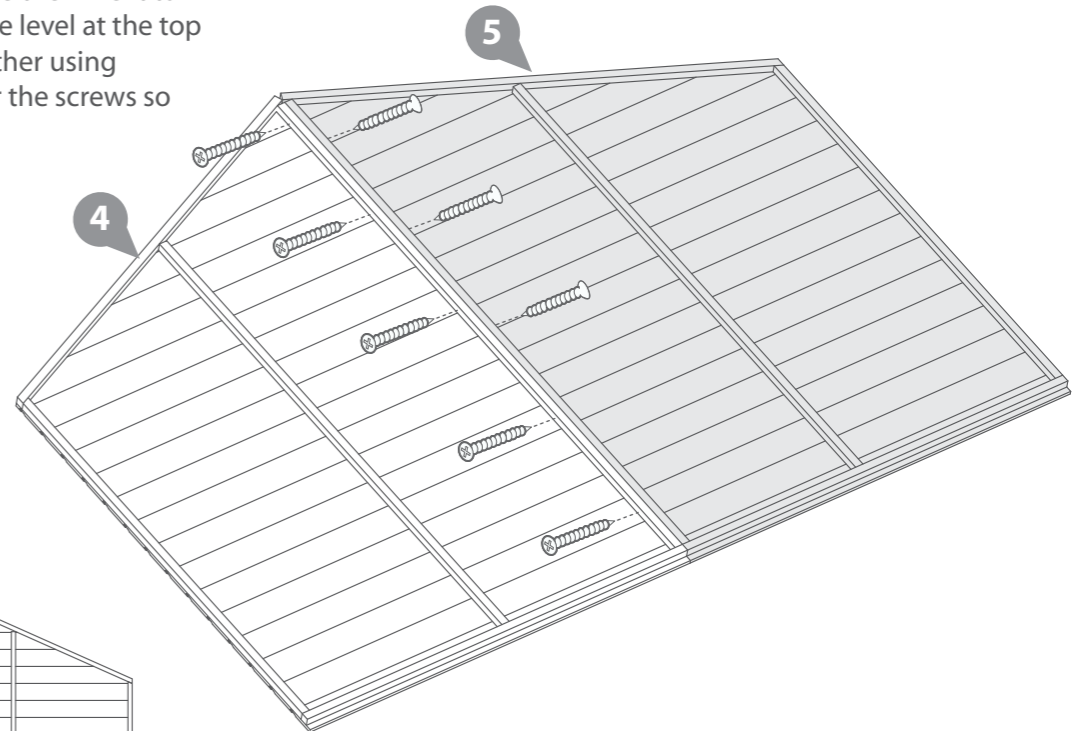
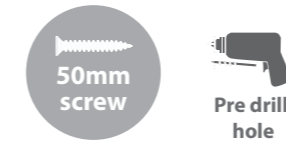

Step 4

Place floor on firm and level base, ensure base has suitable drainage free from areas where water can collect. (See front page on base requirements).

Attach the floors using 8 x 40mm screws

8 x 40mm screws

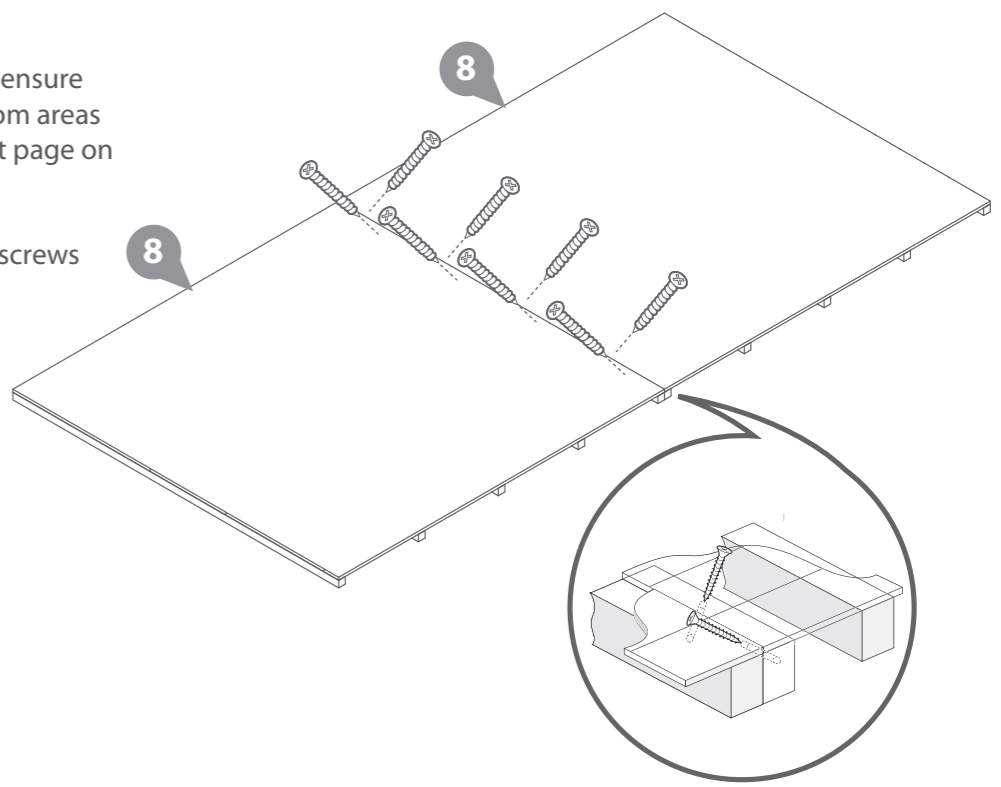

Step 5

Fix another two floor panels using the floor blocks provided.

Place the floor blocks in between the framing as shown in the diagram.

Screw the floor blocks to floor using 2x40mm screws per block screwing through the floor into the floor blocks.

Fix the two floor panels together using the same method shown in step 4 using 8x40mm screws.

Repeat this step once more if you are assembling the 15x10 and another two times if you are assembling the 20x10.

10x10 - 24x40mm screws
15x10 - 48x40mm screws
20x10 - 72x40mm screws

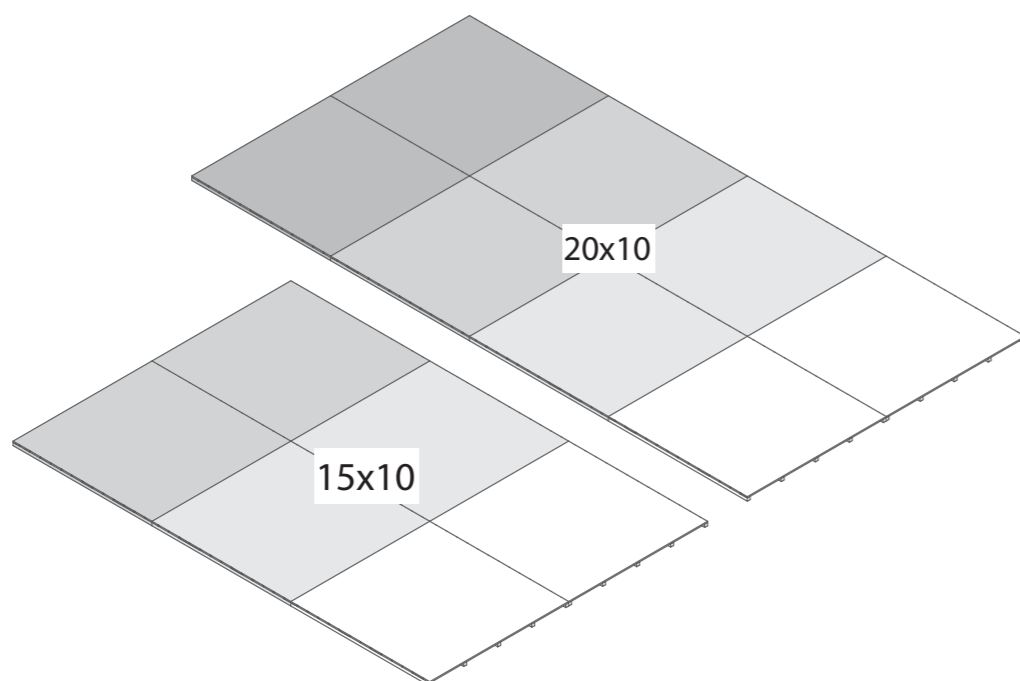
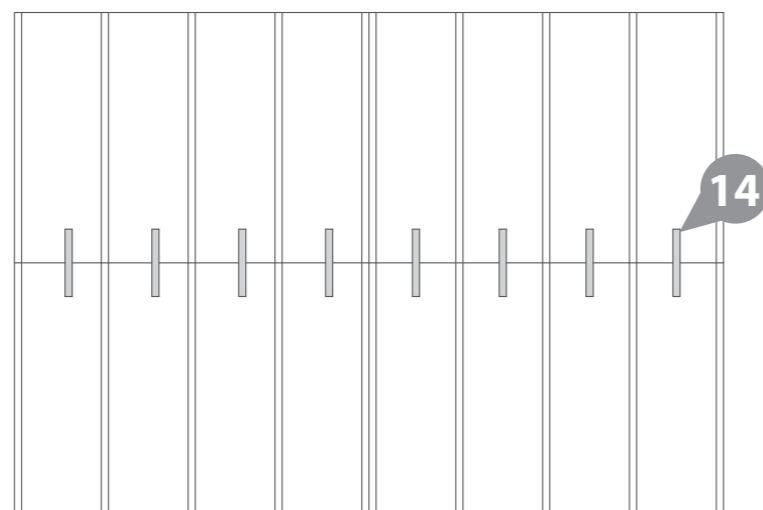
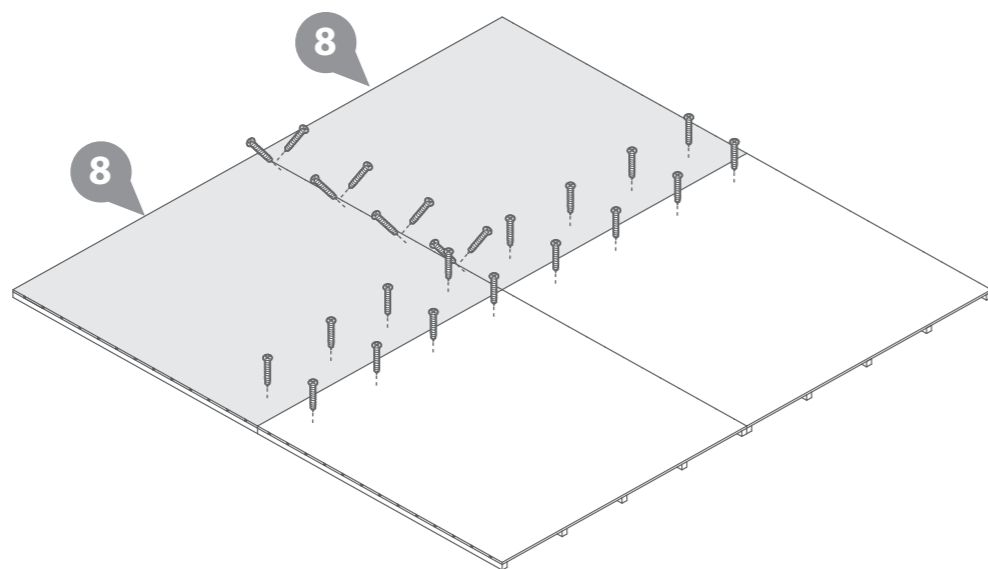
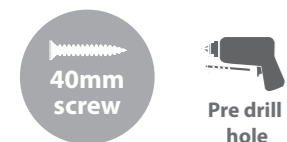

Step 6

a Fix the corners with 50mm screws as shown in diagram.

b Do not secure the building to the floor until the roof is fitted.

Position the panels so there is equal spacing between the floor and cladding on all 4 sides

3x50mm Screws

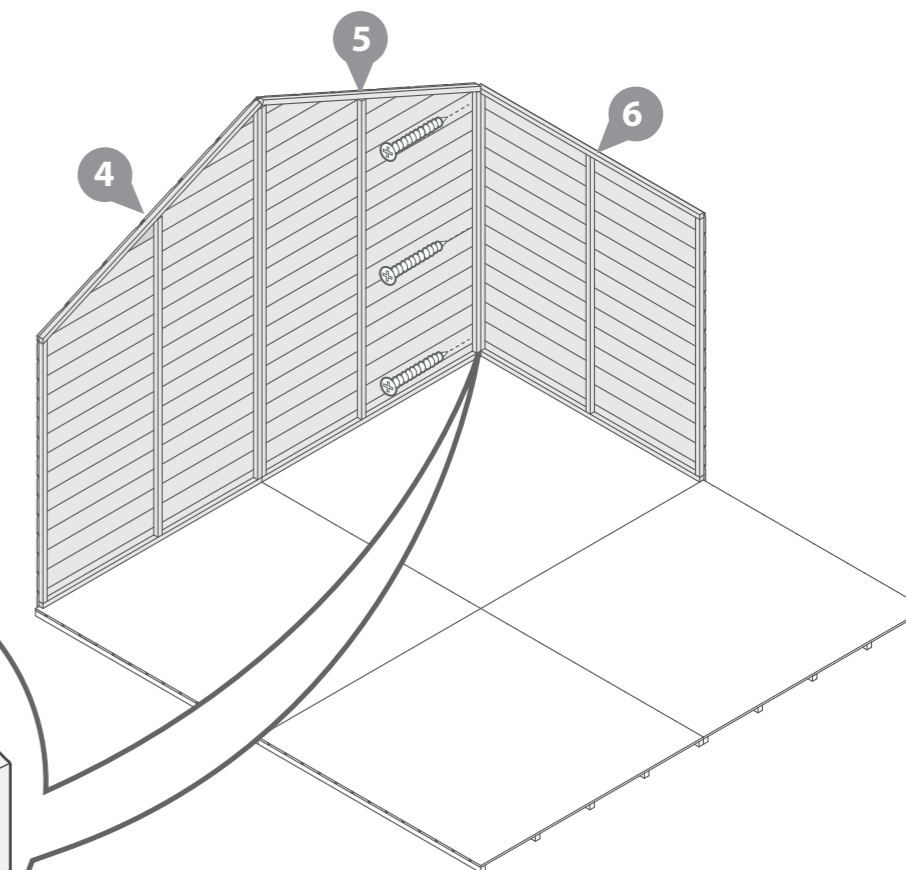
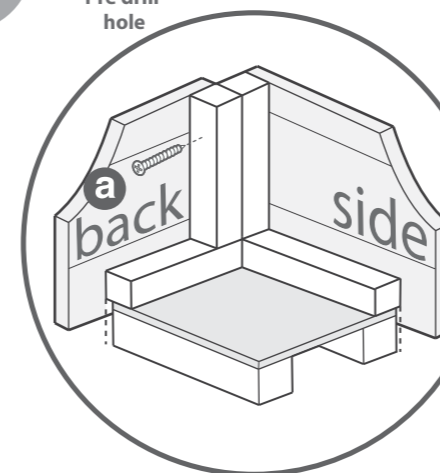
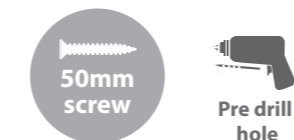

Step 7

Fix the remaining plain side and a window side at the corners with 50mm screws as shown in diagram.

6x50mm Screws

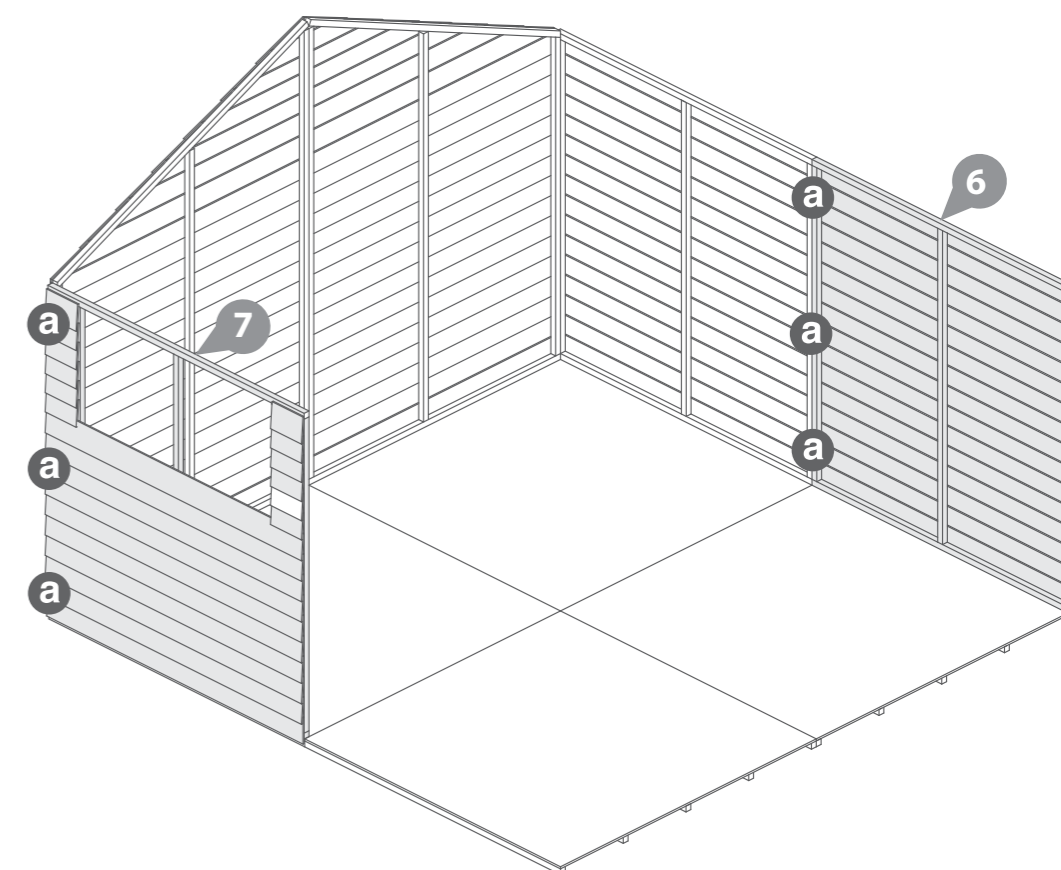
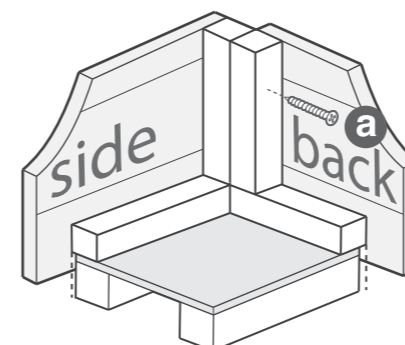
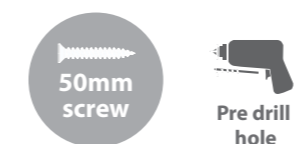

Step 8

Fix the remaining window side at the corners with 50mm screws as shown in diagram.

Continue to add window sides and plain sides using the same method if you are assembling a 15x10 or 20x10.

For a 15x10 you will have an extra Plain and Window Side panel.

For a 20x10 you will have extra two Plain and Window sides.

- 10x10 - 3x50mm Screws
- 15x10 - 9x50mm Screws
- 20x10 - 15x50mm Screws

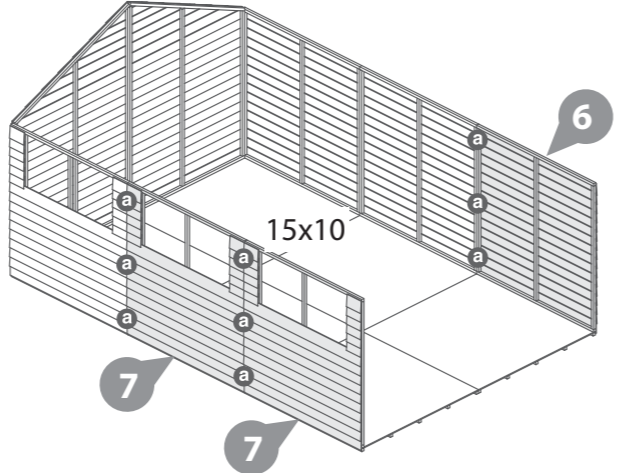
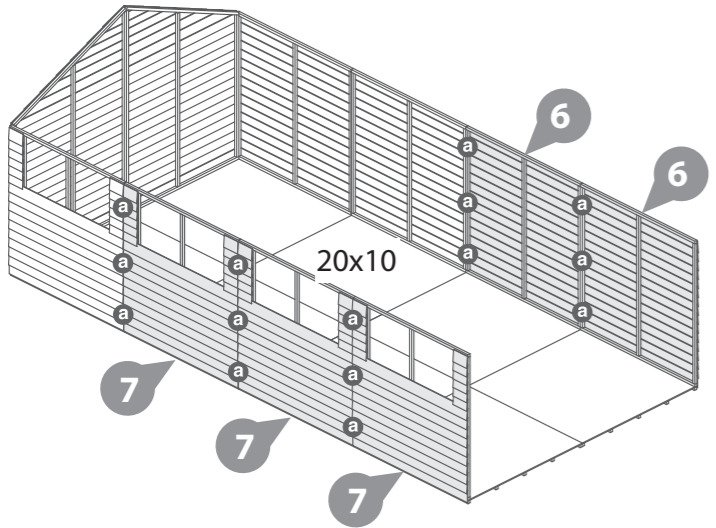
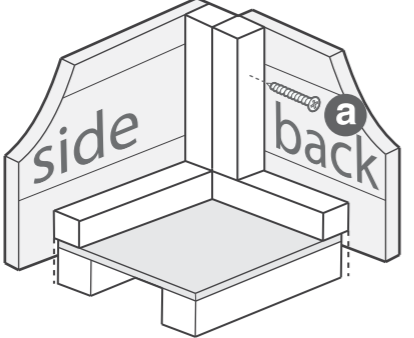
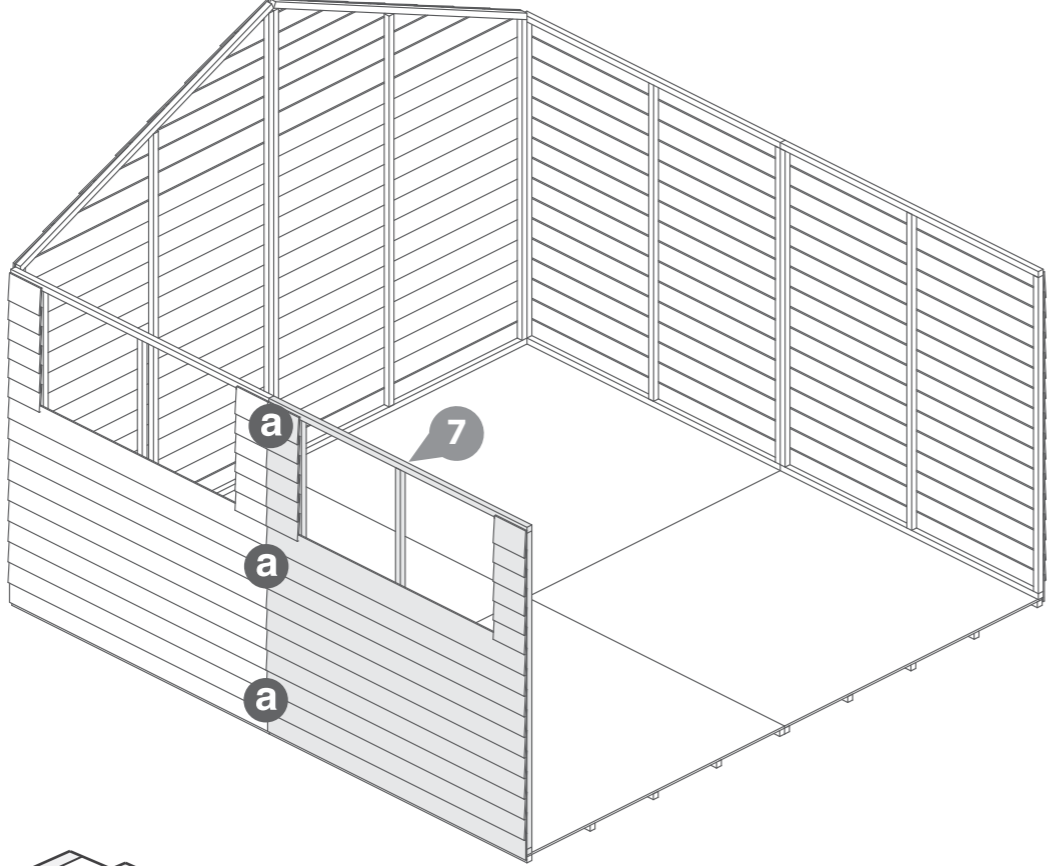

Step 9

Fix the Door Gable (refer to steps 1 and 2 if you have not already assembled this) at the corners with 50mm screws as shown in diagram.

6x50mm Screws

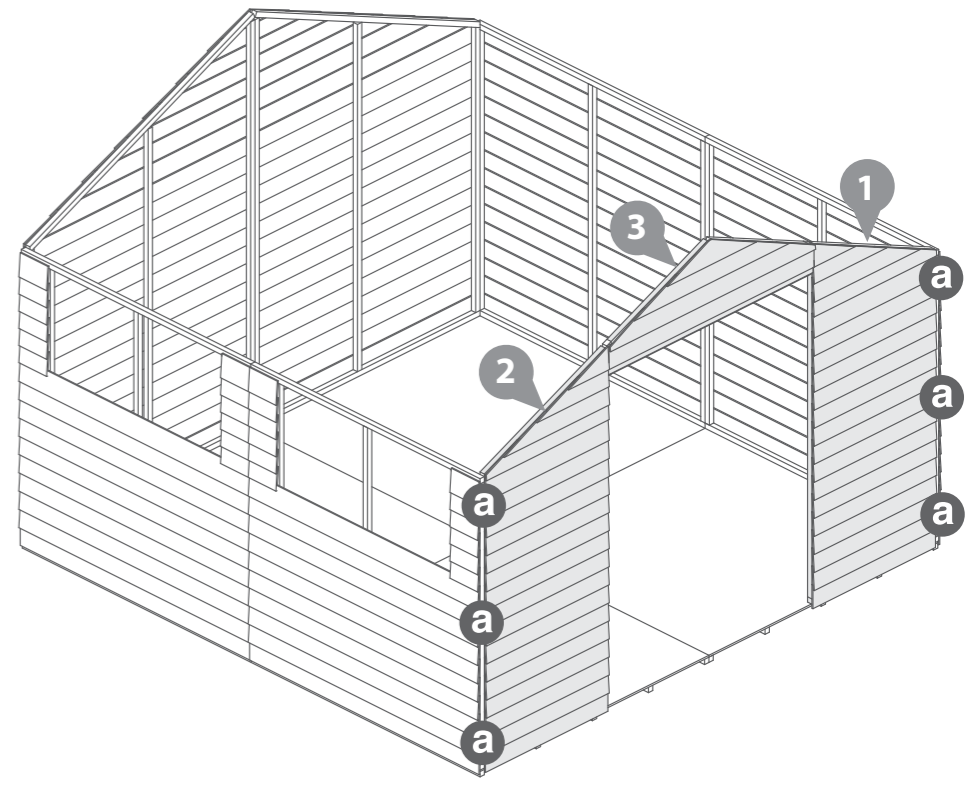
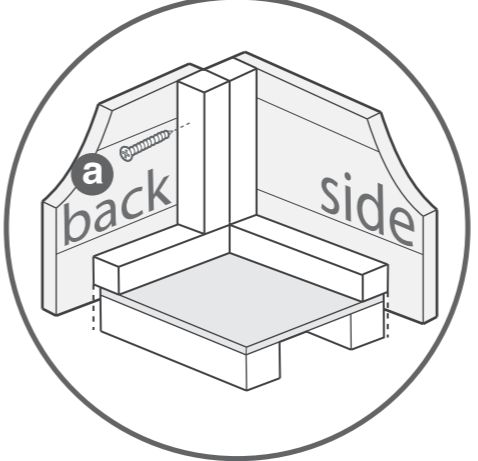

Step 10

Fit the Door Gable Bottom rail between the Front Gable Left and Right. Fix to the floor using 3x50mm screws making sure the screws go through to the floor framing.

3x50mm Screws

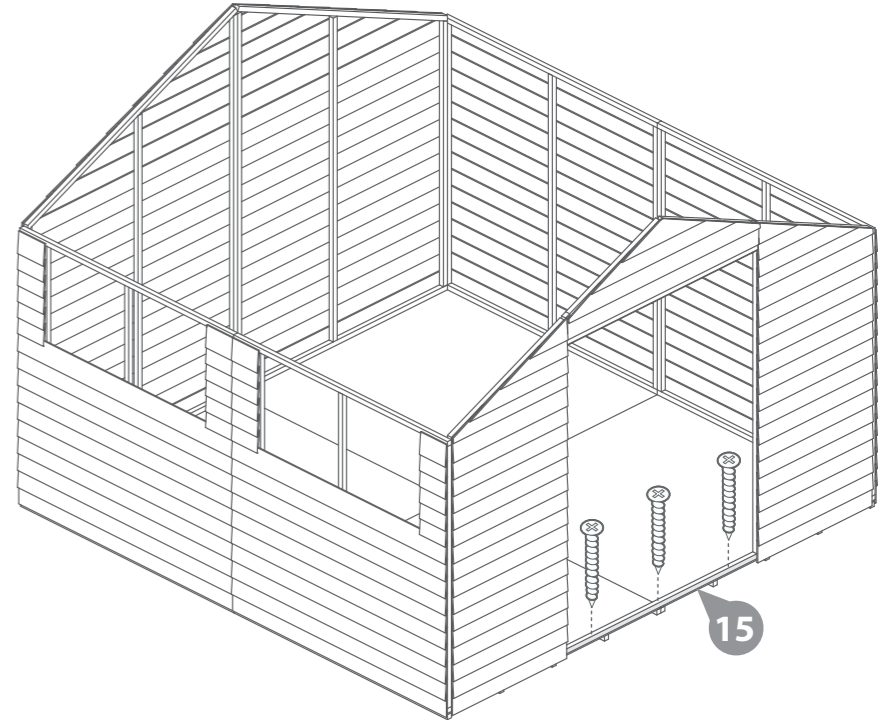
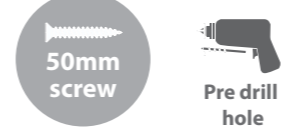

Step 11

Fix the T Hinges onto the doors and door gable as shown. Ensure that the screws go through the cladding and into the framing behind.

42x30mm screws

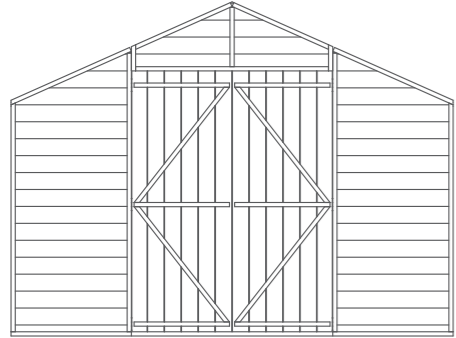
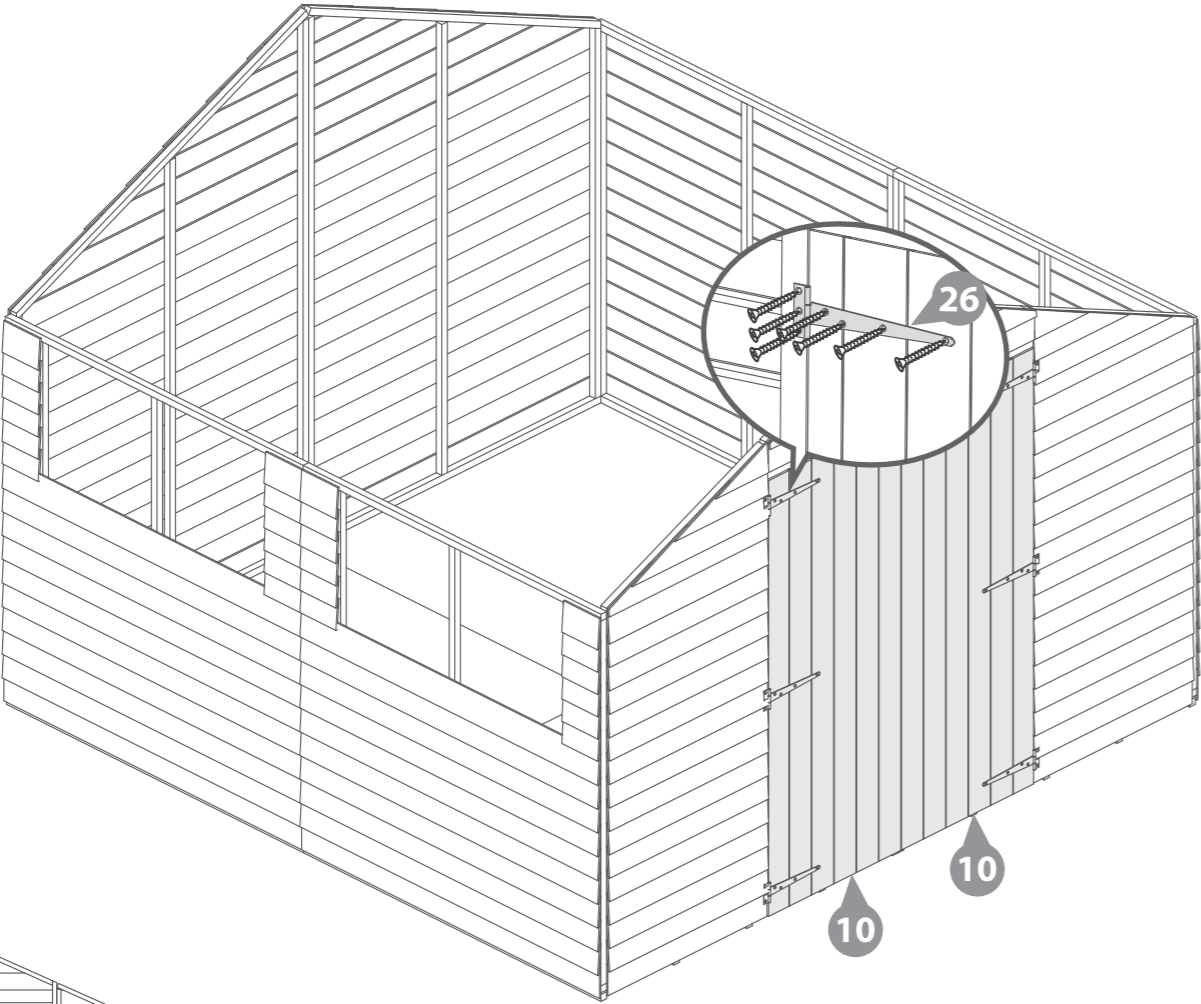

Internal View

Step 12

Place a Truss central to where two panels join. Align the top of the truss with the top of the sides as shown in the diagram.

HINT - Use a piece from the fixing kit as a guide.

Pencil mark the truss position and remove truss.

Place the truss blocks up to the pencil mark and fix using 2x70mm screws per block.

Place the truss back into position on top of the support block and secure using 100mm screw each side from the top down through the truss and into the block.

For 15x10 and 20x10 build a truss where each panel joins, for 15x10 you will have two trusses and for the 20x10 you will have three trusses.

10x10 - 4x70mm Screws
2x100mm Screws

15x10 - 8x70mm Screws
4x100mm Screws

20x10 - 12x70mm Screws
6x100mm Screws

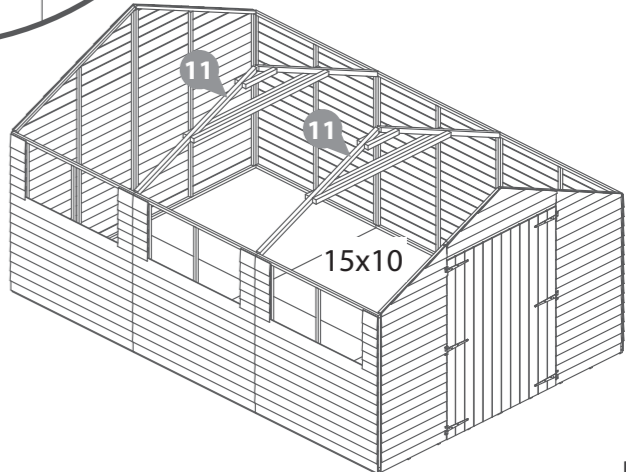
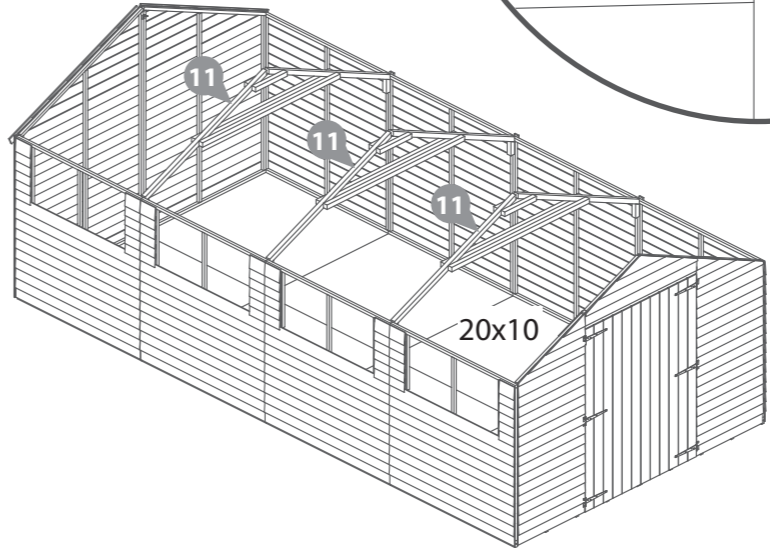
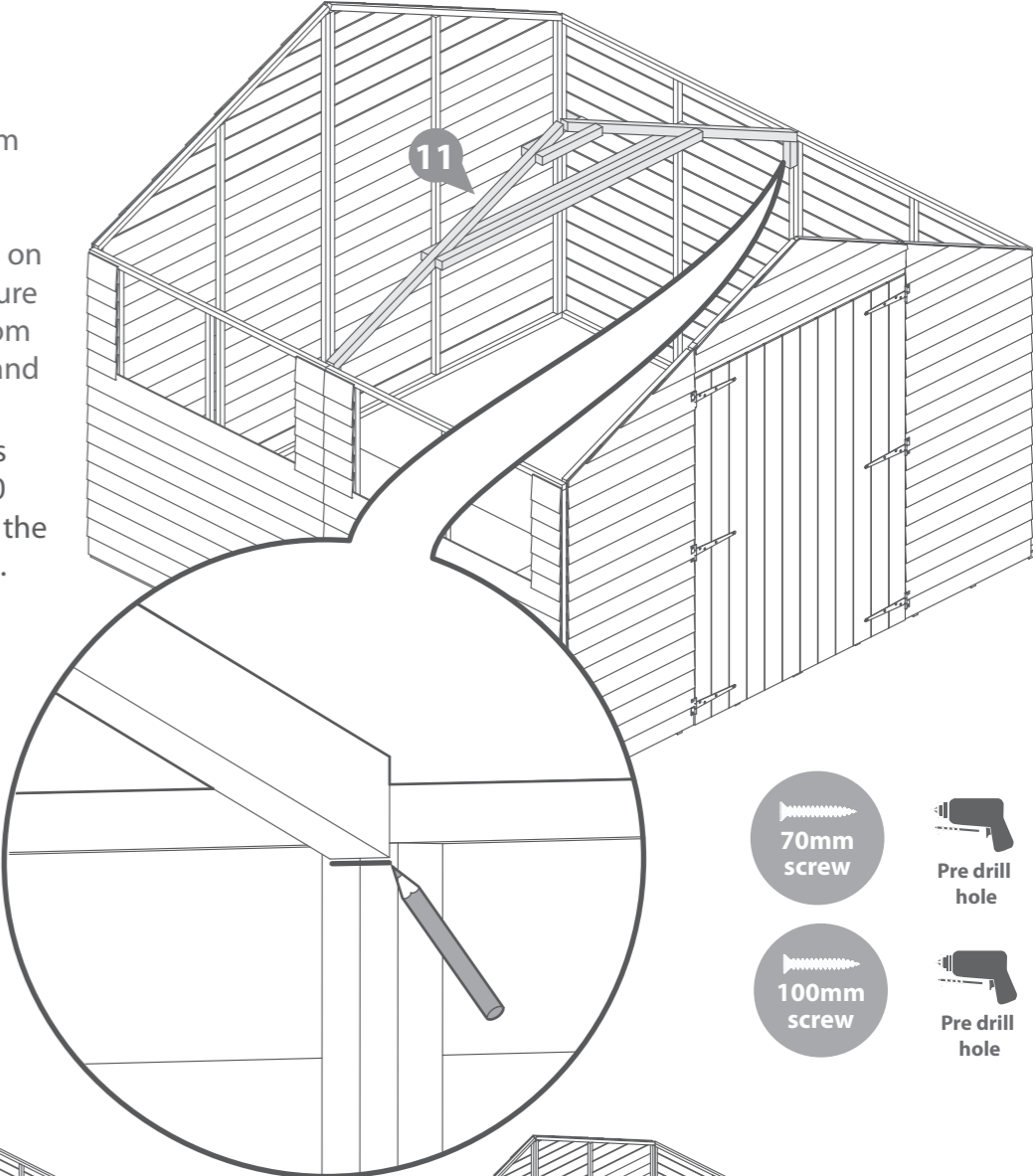
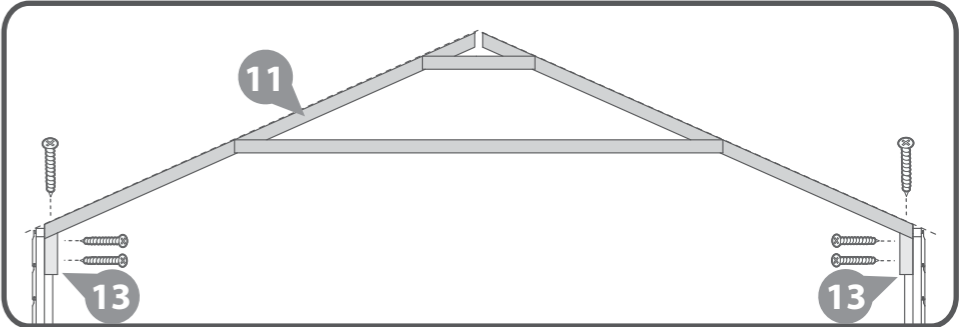

Step 13

Place the two ridge bars in between the front and back panels. Ensure the top corners of the support bar are flush with each top point. Secure in place using the L Bracket on each end with 4x30mm screws. Using a 70mm screw secure the ridge bar to the truss by screwing through the underneath of the truss into the ridge bar.

- 10x10 - 2x70mm Screws
- 8x30mm Screws
- 15x10 - 4x70mm Screws
- 8x30mm Screws
- 20x10 - 6x70mm Screws
- 8x30mm Screws

For a 15x10 building you will need to add another Ridge Bar.
For a 20x10 building you will need to add another two ridge bars.

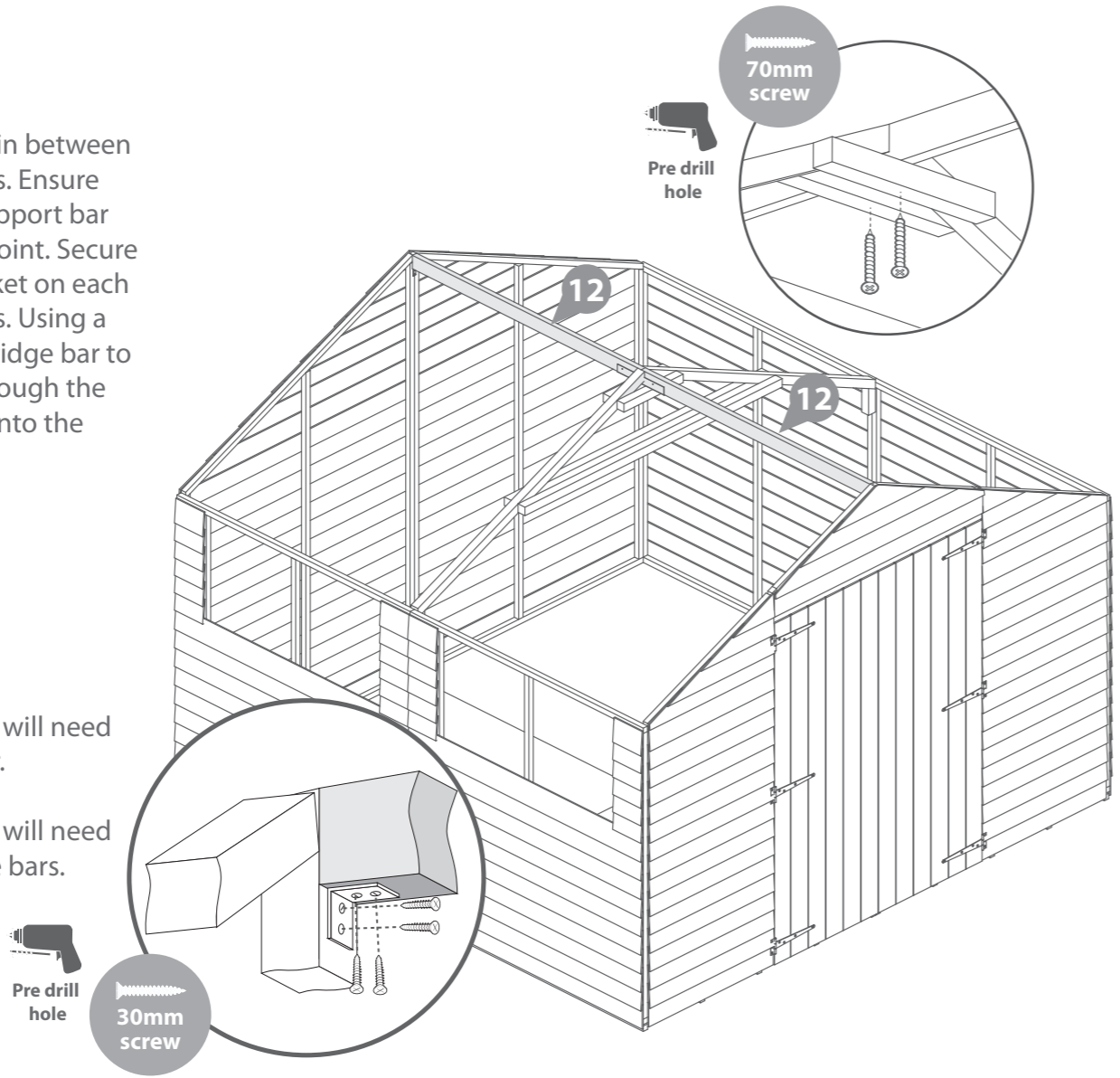

Step 14

Fix the eaves frame to the roof sheet using 4x30mm screws for each sheet.

8x30mm Screws

Place two roof sheets on top of the plain gable and truss making sure the roof sheet sits flush to the outside edge of the plain gable and fix using 40mm screws. Before fixing the roof sheet to the truss frame make sure the edge of the roof sheet sits in the middle of the truss then fix using 40mm screws.

24x40mm Screws

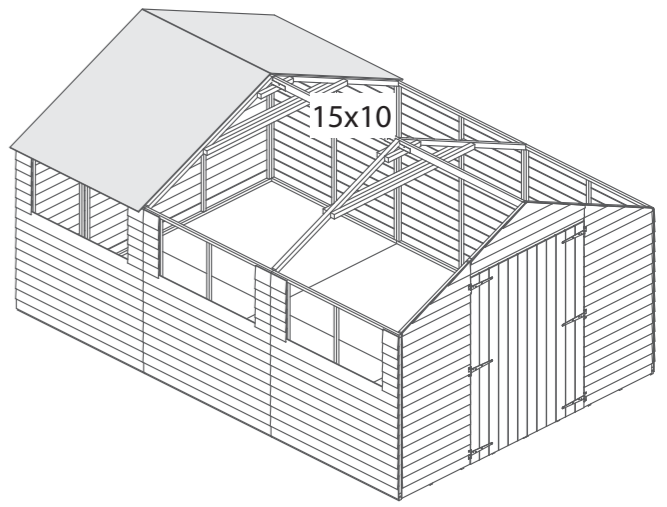
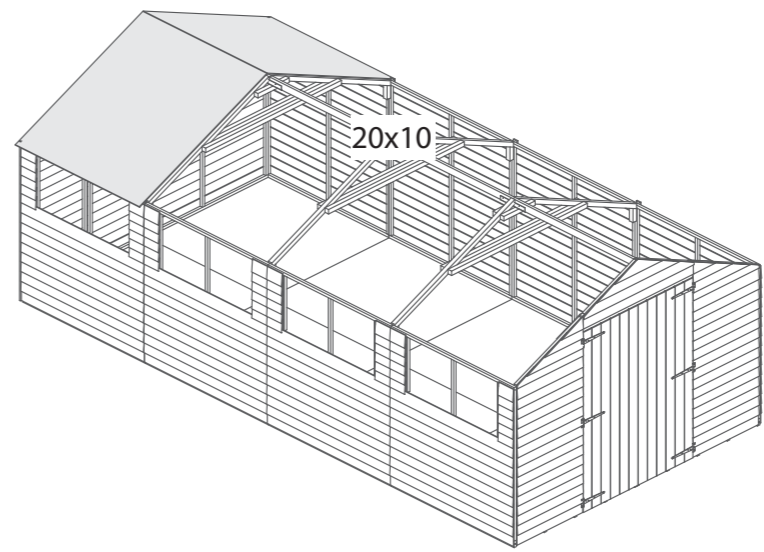
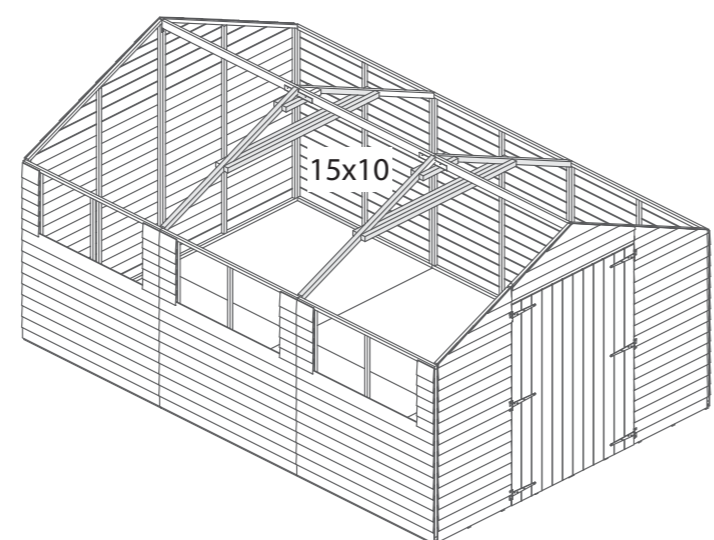
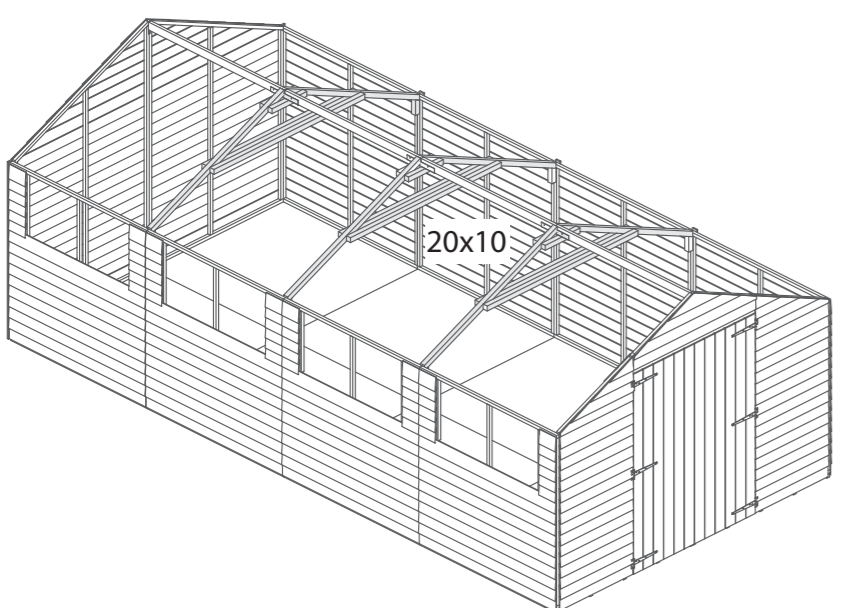
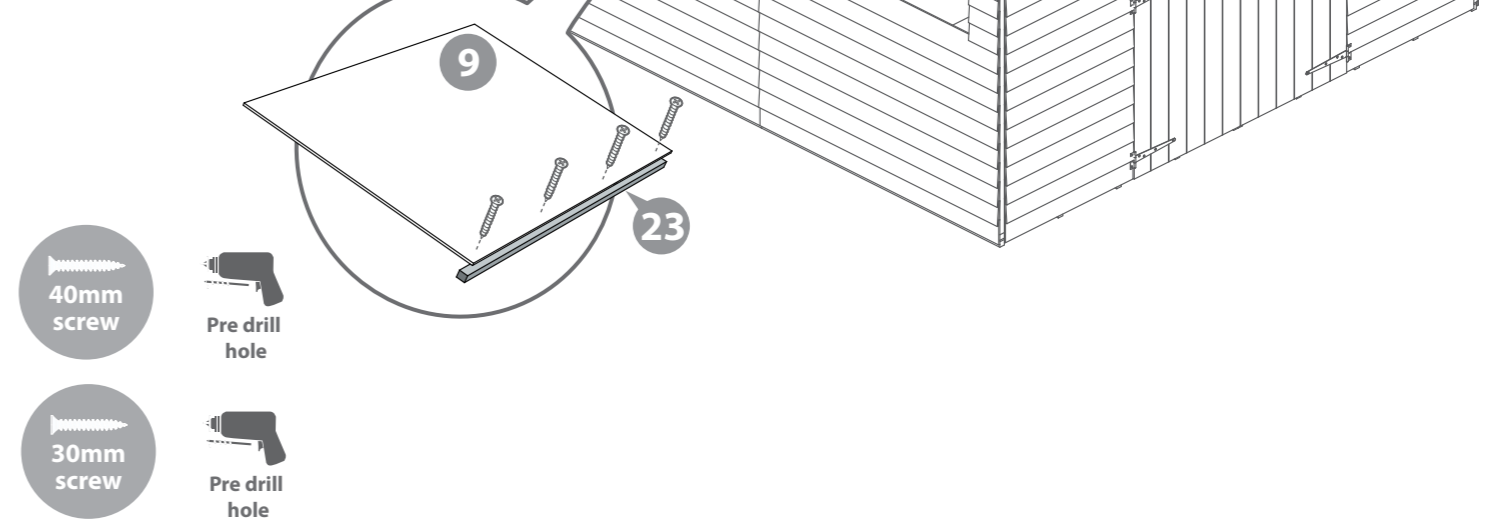

Step 15

Fix the remaining eaves frames to the remaining roof sheets using 4x30mm screws per sheet.

Place the roof sheet on top of the truss and ensure that it butts up to the one already fixed. Fix in place with 40mm screws ensuring they go through to the framing.

For 15x10 & 20x10 buildings continue this process until the roof is complete.

- 10x10 - 8x30mm Screws
- 24x40mm Screws
- 15x10 - 16x30mm Screws
- 48x40mm Screws
- 20x10 - 24x30mm Screws
- 72x40mm Screws

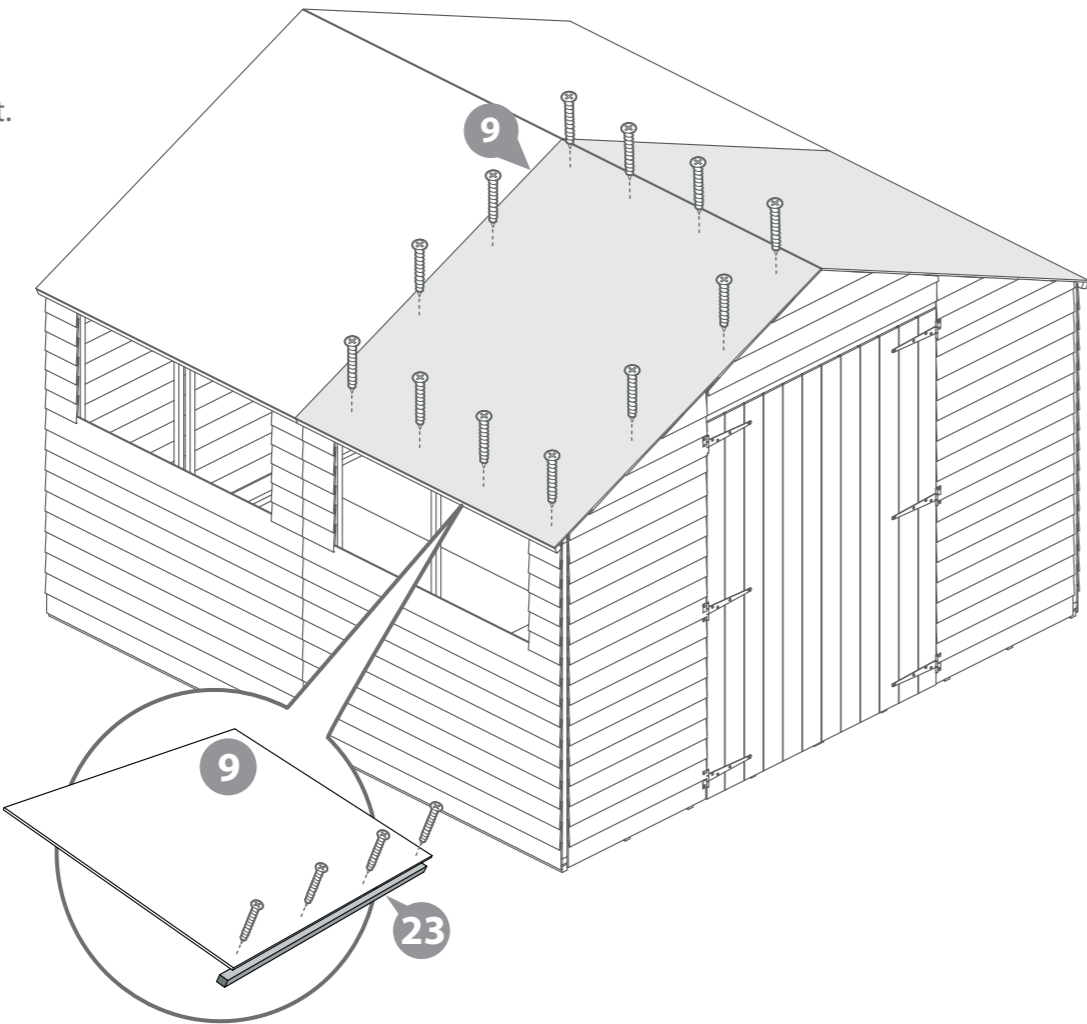
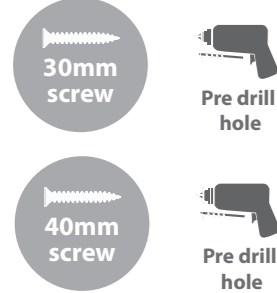

Step 16

Once the roof is fixed attach the building to the floor with 50 mm screws.

- 10x10 - 24 x 50mm Screws
- 15x10 - 40 x 50mm Screws
- 20x10 - 56 x 50mm Screws

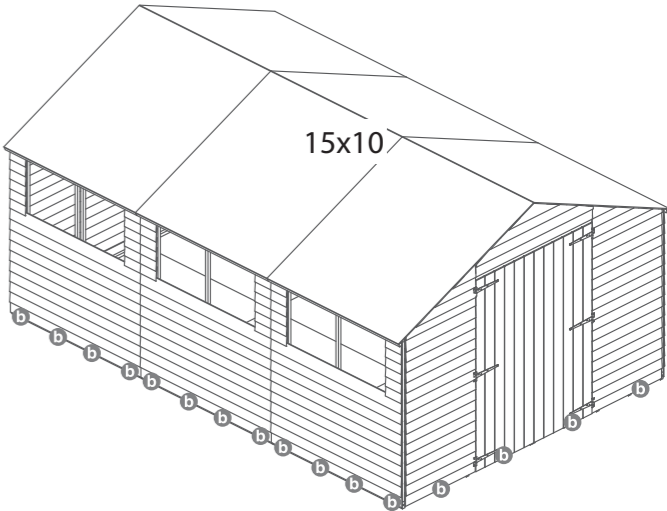
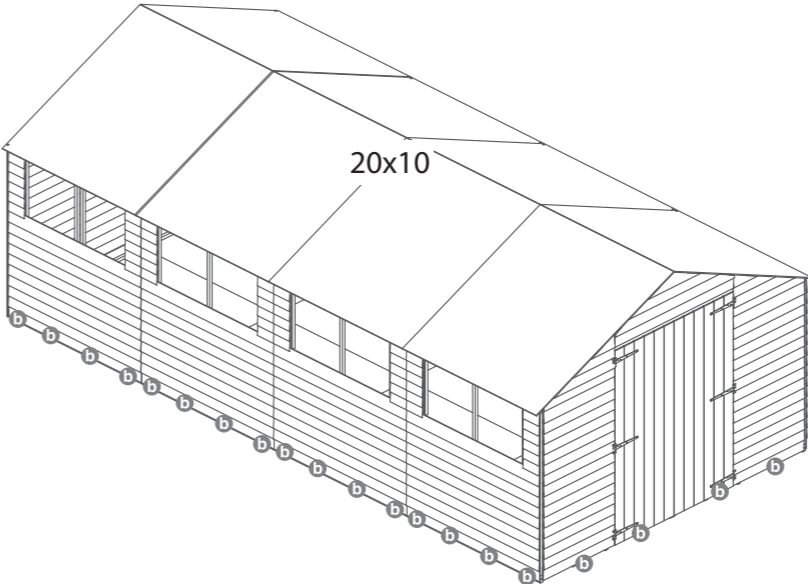
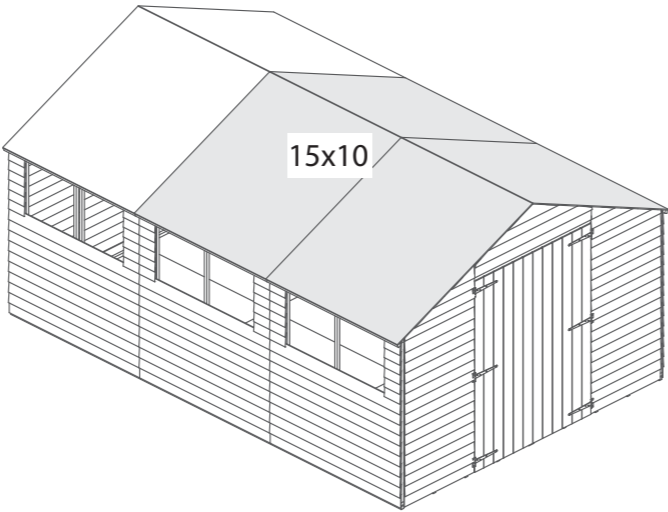
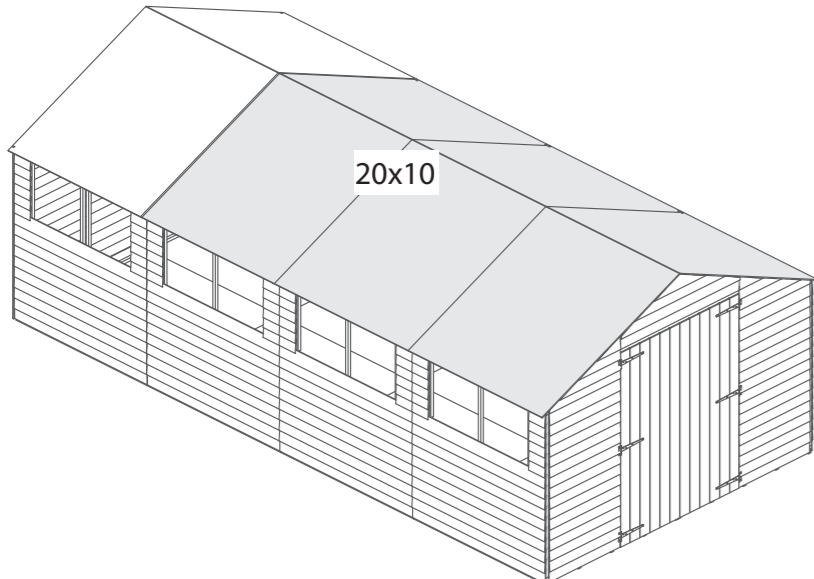
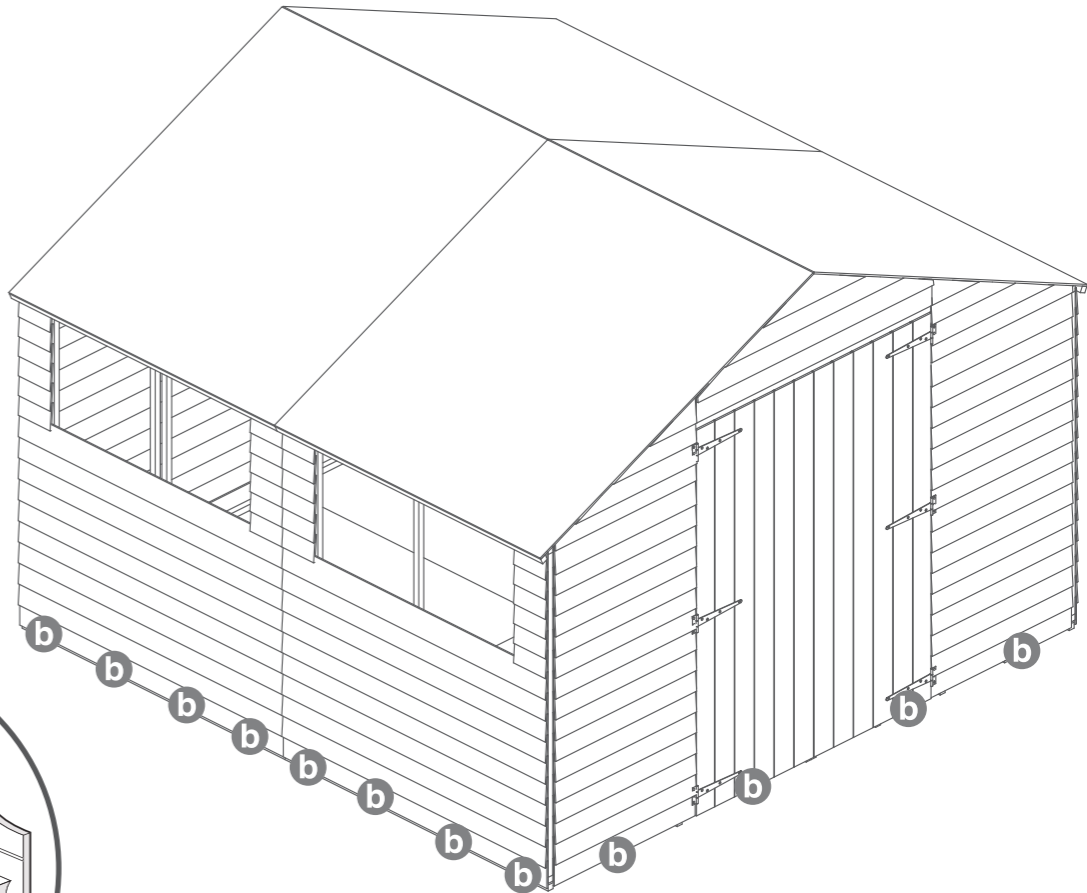
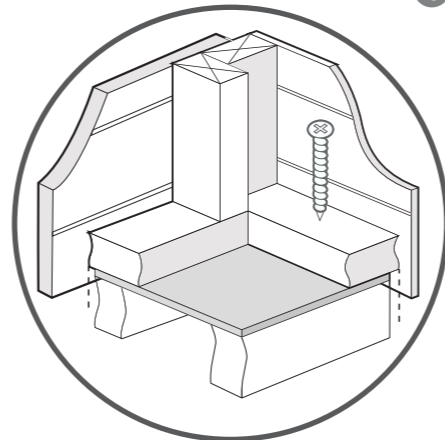

Step 17

Cut four strips of felt and place onto the roof. See below for sizes.

Place the felt flat onto the roof in the order that is stated on the diagram below.

Once the sheets are laid out fix them onto the roof with tacks 100mm apart.

- Felt Strip Sizes**
 10x10 - 3210mm
 15x10 - 4690mm
 20x10 - 6180mm

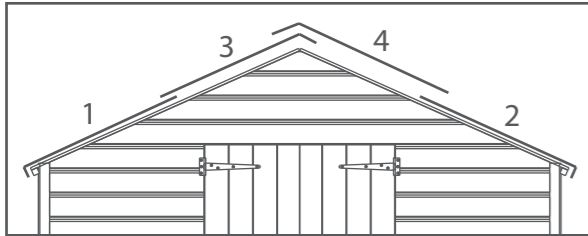
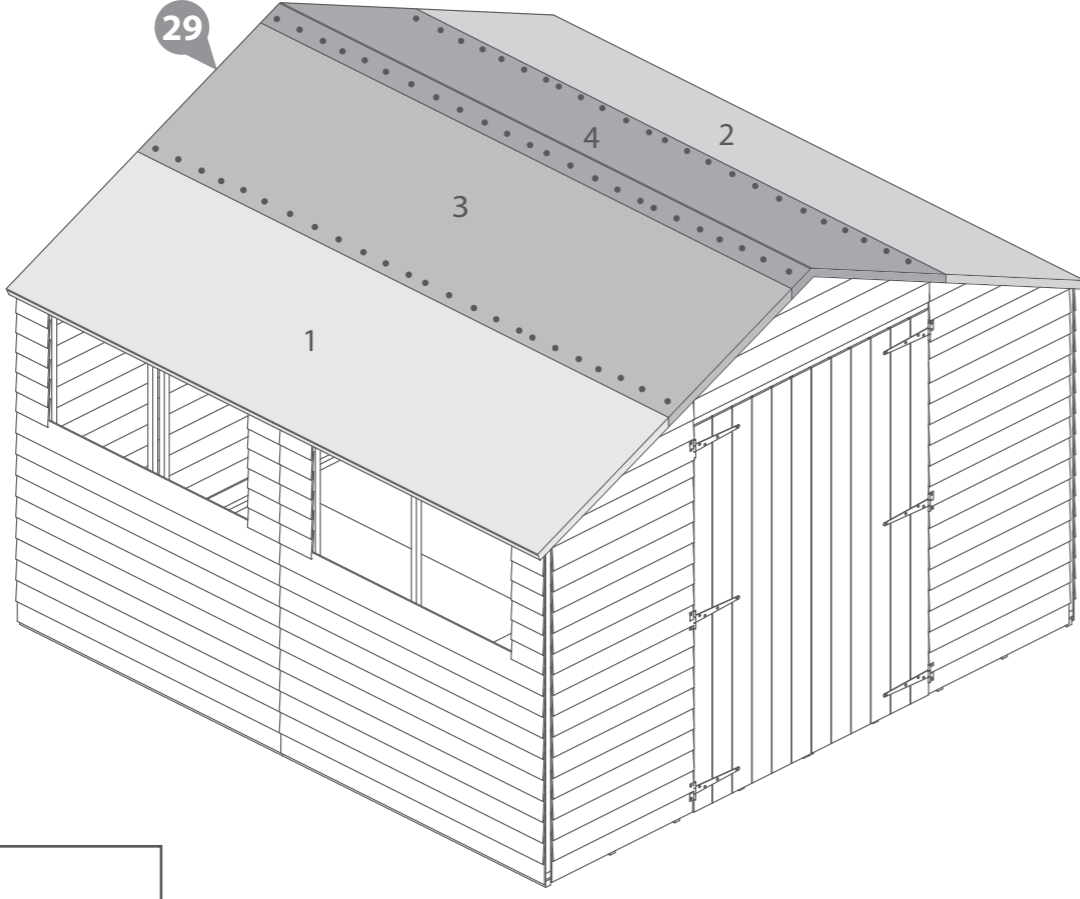

- 10x10 - 170 x felt tacks
 15x10 - 240 x felt tacks
 20x10 - 310 x felt tacks

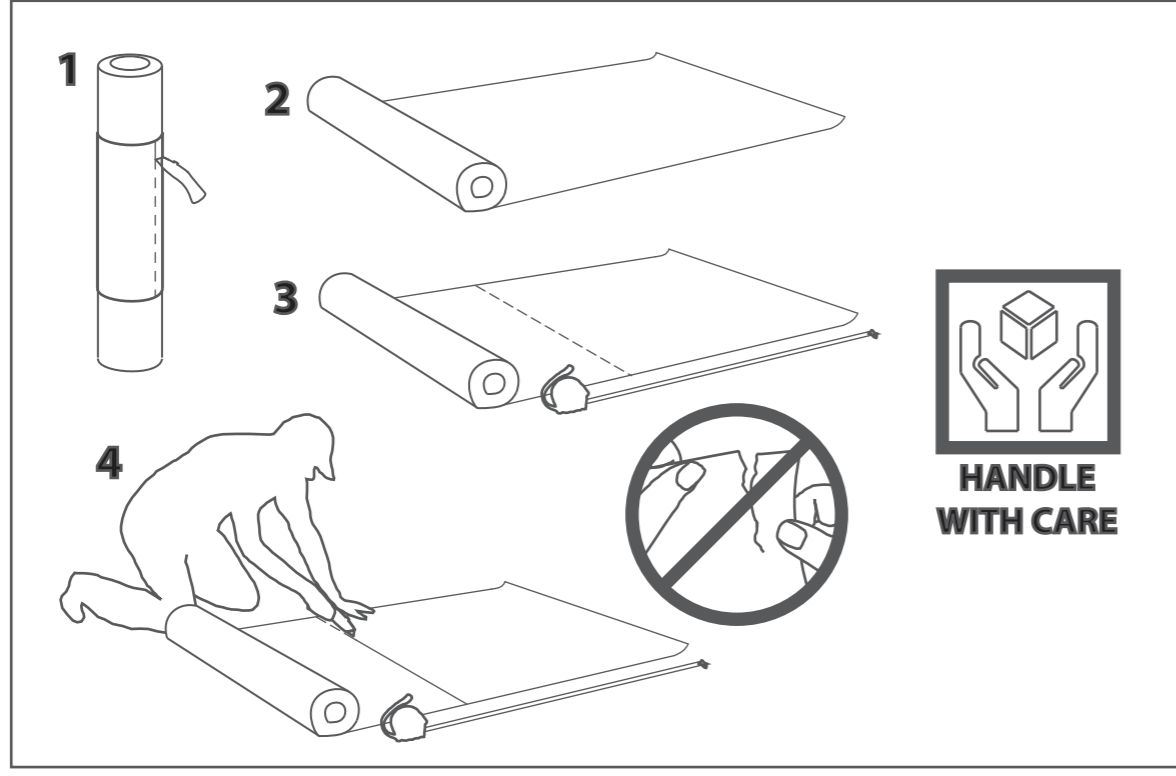

Step 18

Fit the cover trims to the building and secure in place with 40mm screws as shown. Fit the Plain Gable Strip where the two back gables join using 4x40mm screws. Pre drill to avoid splitting.

- 10x10 - 22x40mm Screws
 15x10 - 28x40mm Screws
 20x10 - 34x40mm Screws

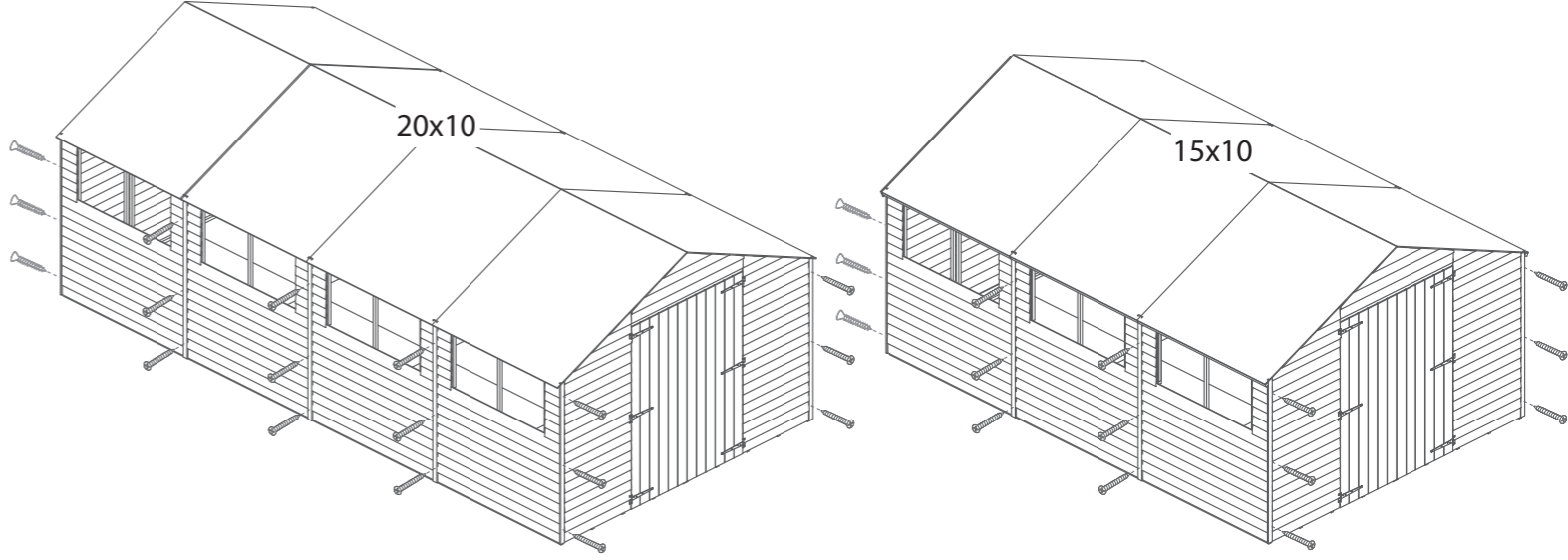
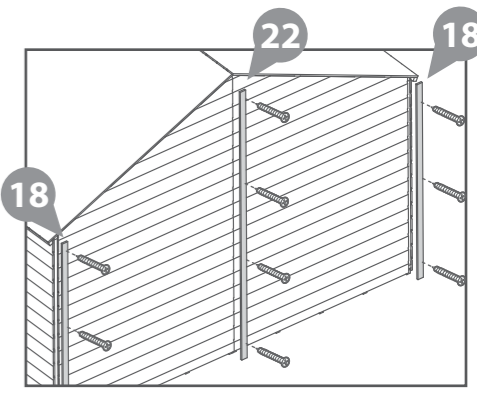
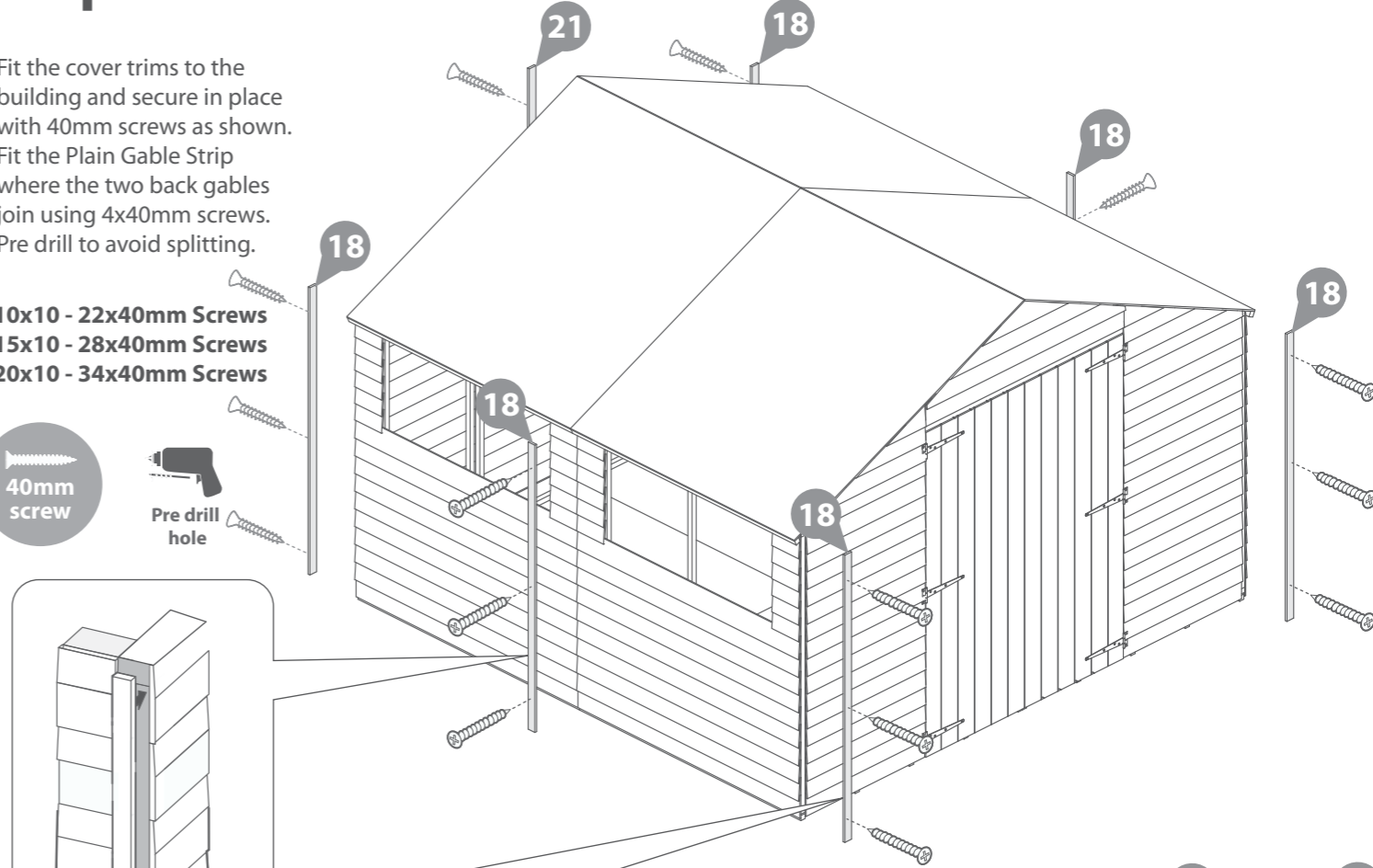

Step 19

Attach fascias to the roof leaving a slight overhang at the top.

Fit the fascias to the roof over the felt and secure in place with 40mm screws as shown. Pre drill to avoid splitting.

16x40mm Screws

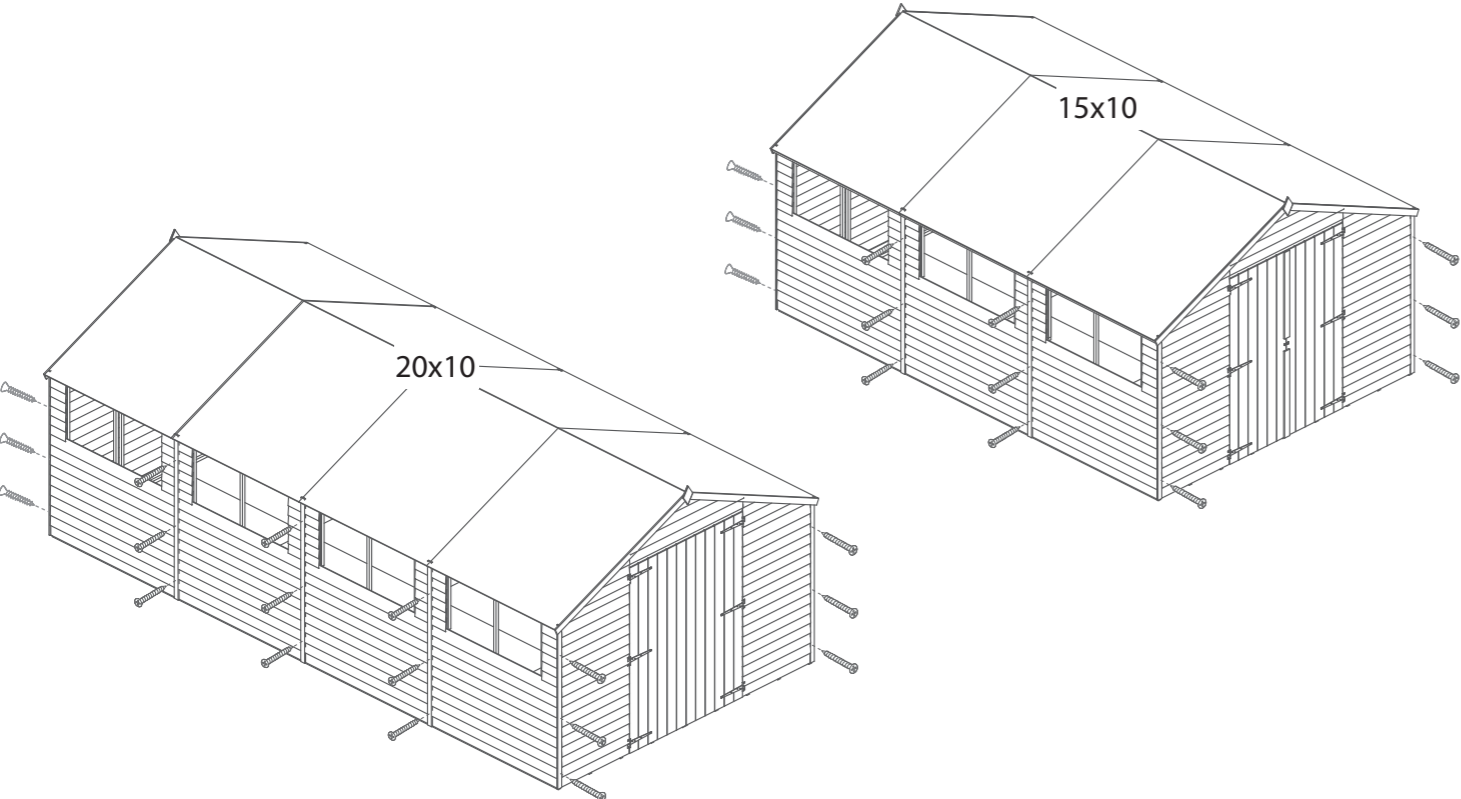
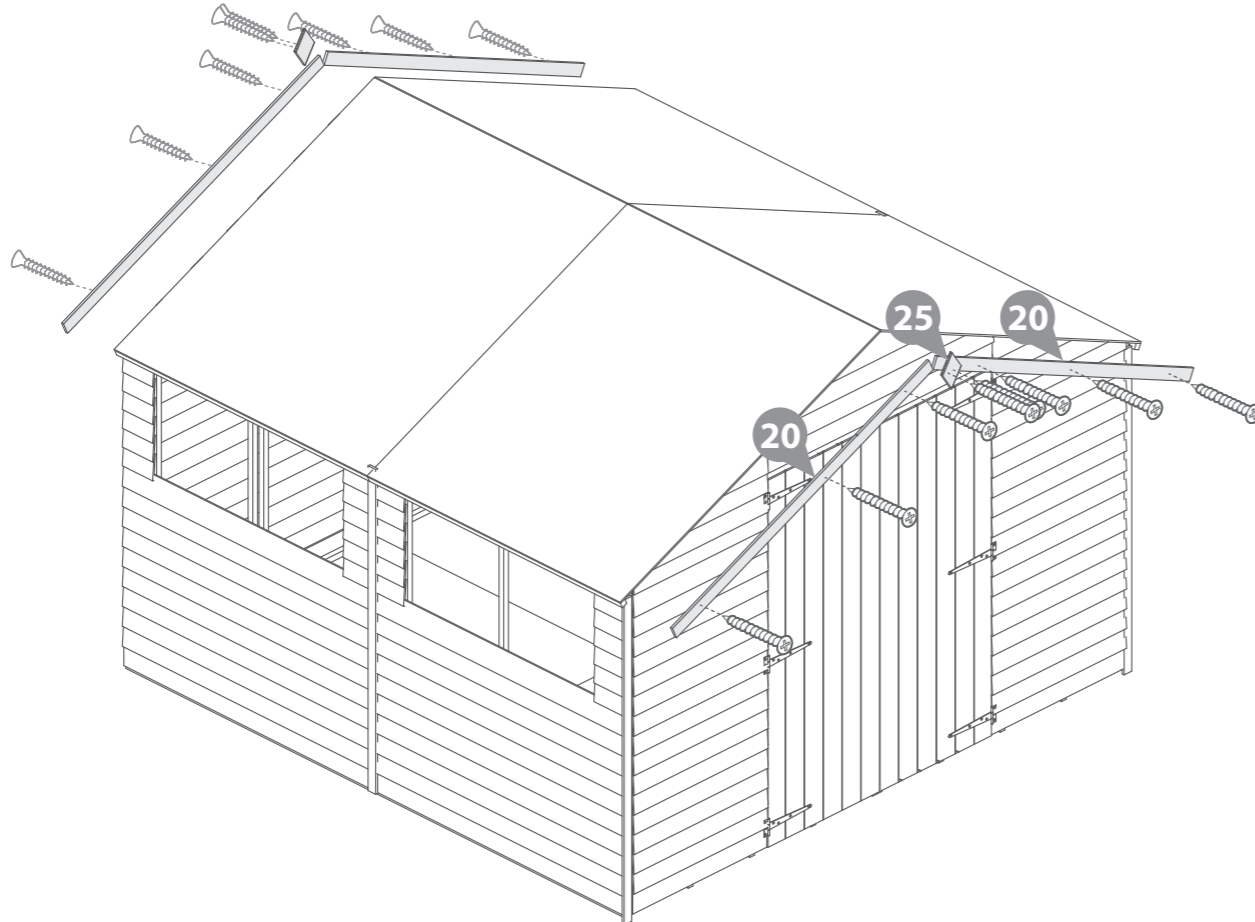

Step 20

- a** First line up the door blocks on top of the framing of the doors. Then fix with 2x30mm screws by screwing through the matchboard door into the block. The two central blocks are only for 01SHPA buildings
8x30mm Screws
- b** Use 4x30mm Screws to fix each beading strip onto the door gable. Ensure that the screw is parallel with the door frame when fixing the strip to the door gable as shown in the close up view.
8x30mm Screws
- c** Attach the turn button to the top and bottom door blocks with 1x30mm screw for each one.
2x30mm Black Screws

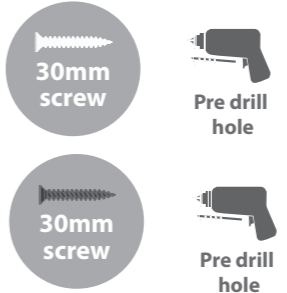
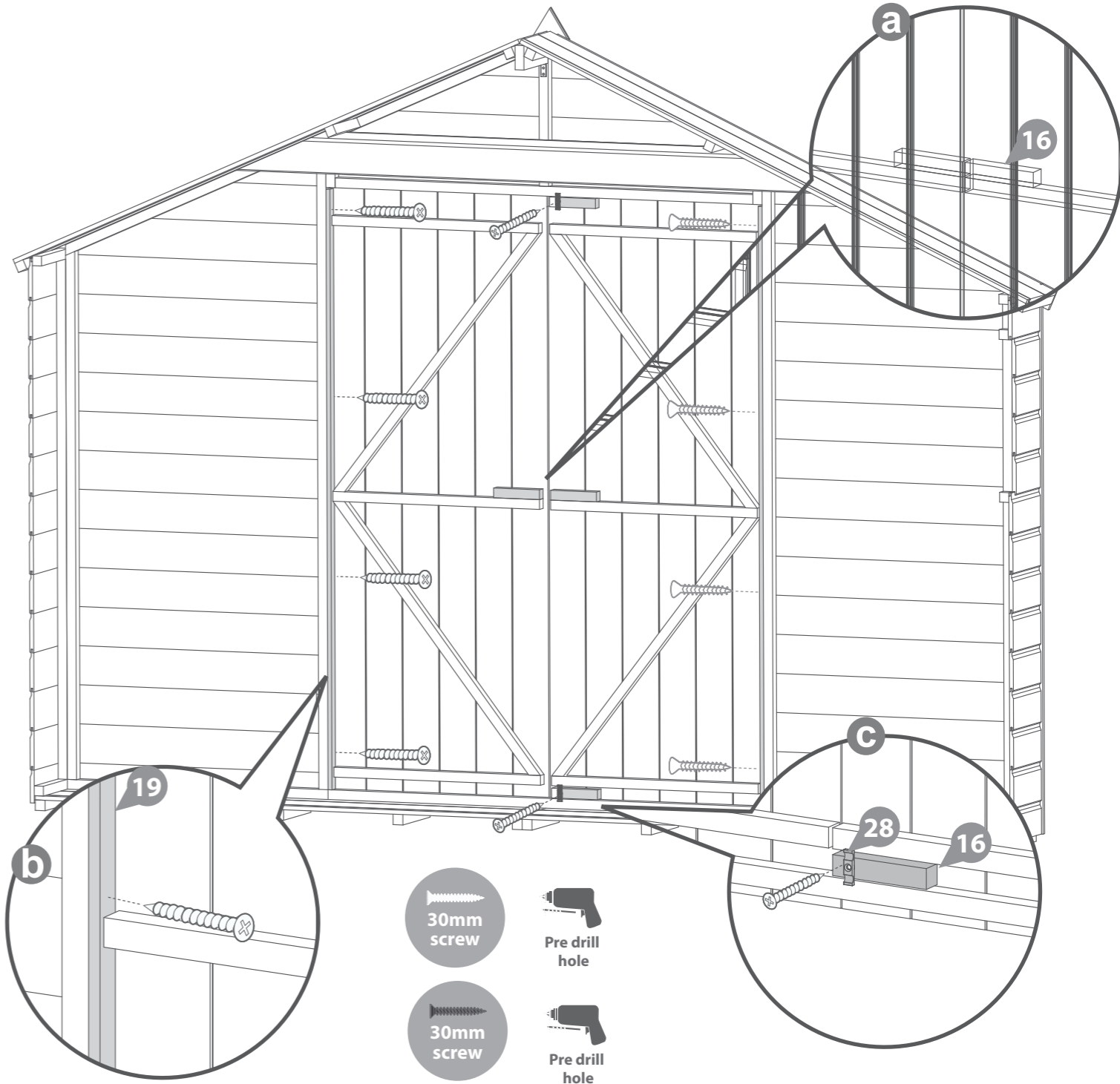

Step 21

a Fix the door strips to the master door using 5x30mm screws.
If the strips are attached to the slave door the doors will not open properly.

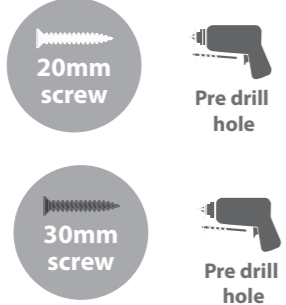

6x20mm Screws
b Use 1x30mm screw to secure the turn button to the master door.

1x30mm Black Screws

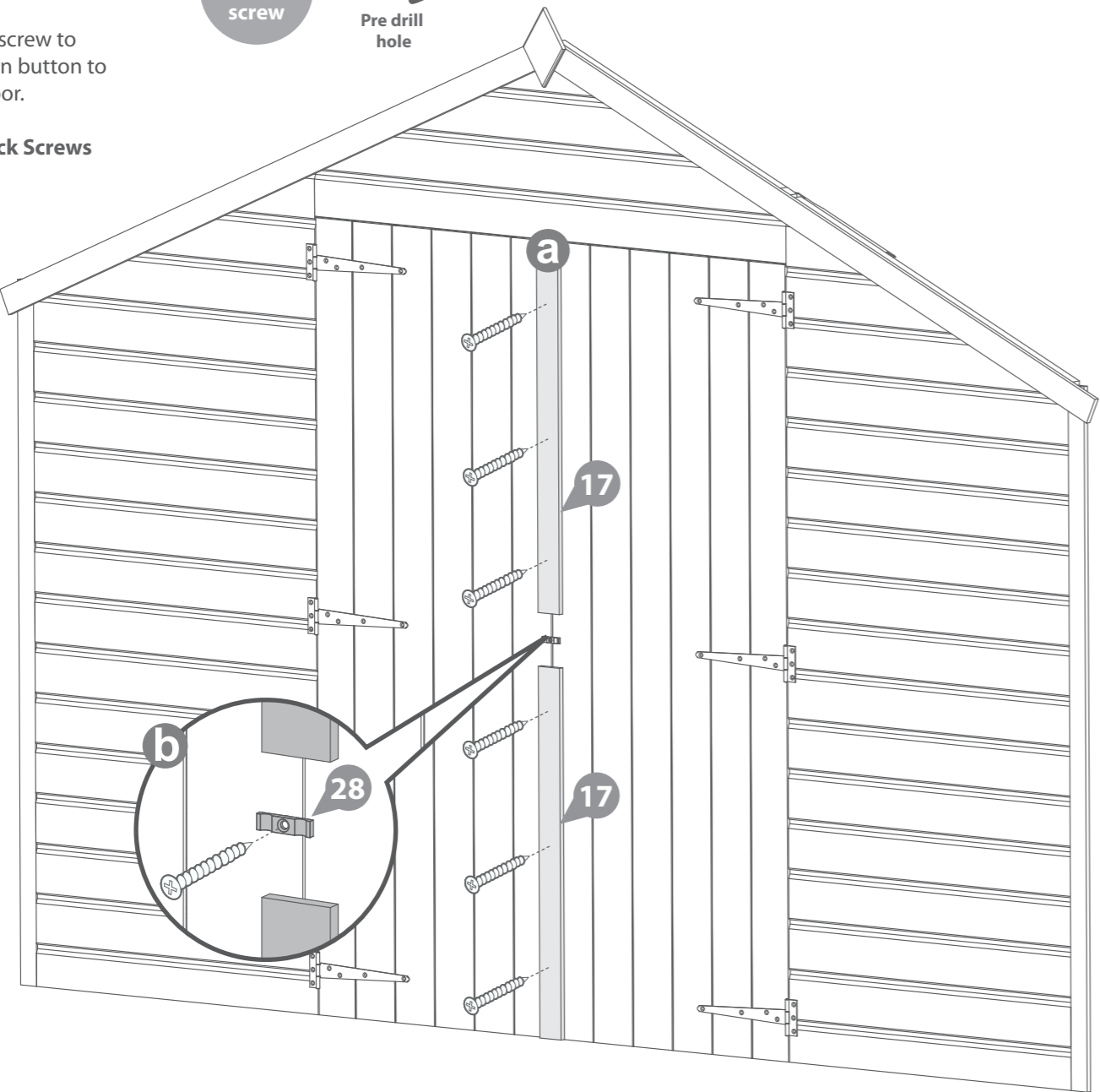

Step 22

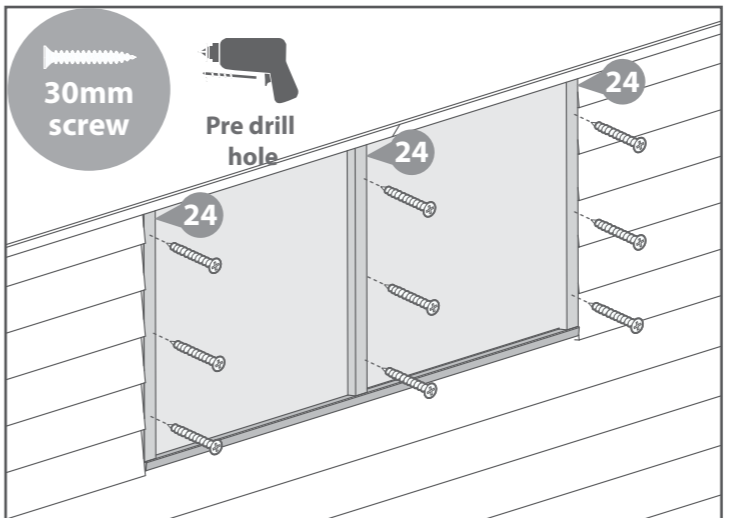
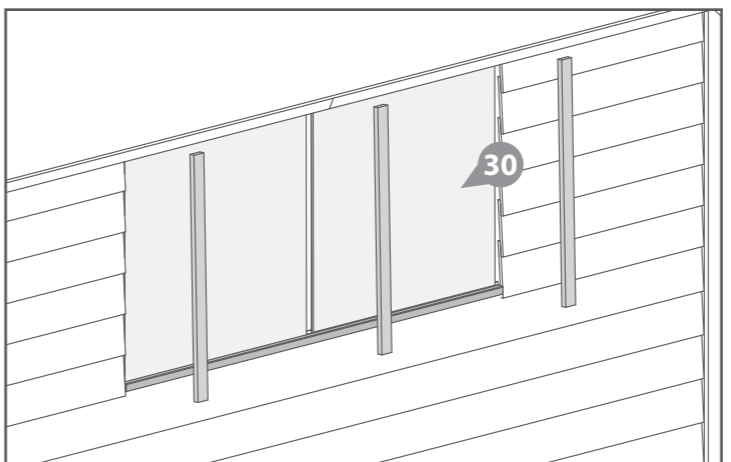
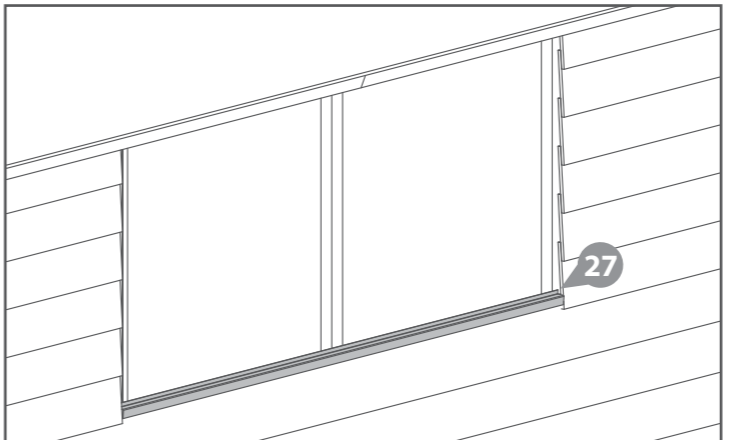
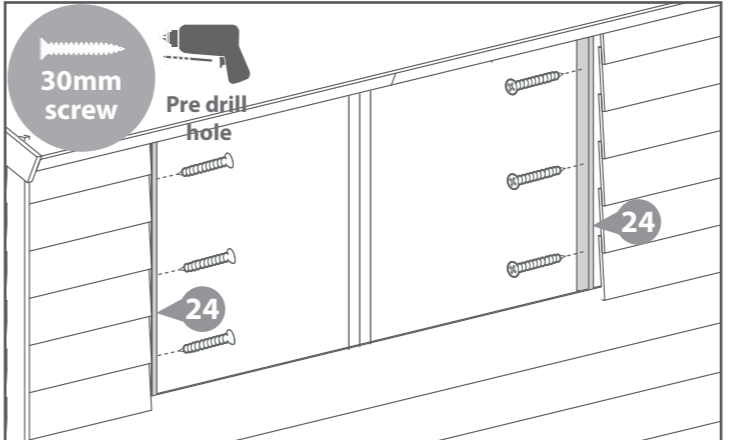

Fix the window strips to the two pieces of framing that sit alongside the outside edges of the window with 3x30mm screws for each strip.

6x30mm Screws

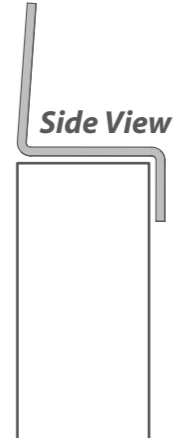

Side View
Place the plastic window cill onto the Window Panel in the same way as shown on both diagrams to the left.

Fit the styrene sheets on top of the window cill.

When positioning the styrene sheets ensure there is an equal distance between them and at either side of the windows.

Attach the three window strips at either side of the windows using 3x30mm screws each. Make sure the screws enter the framing in the window panel and not the styrene.

9x30mm Screws



It is ESSENTIAL that you apply wood treatment immediately after the building has been assembled.

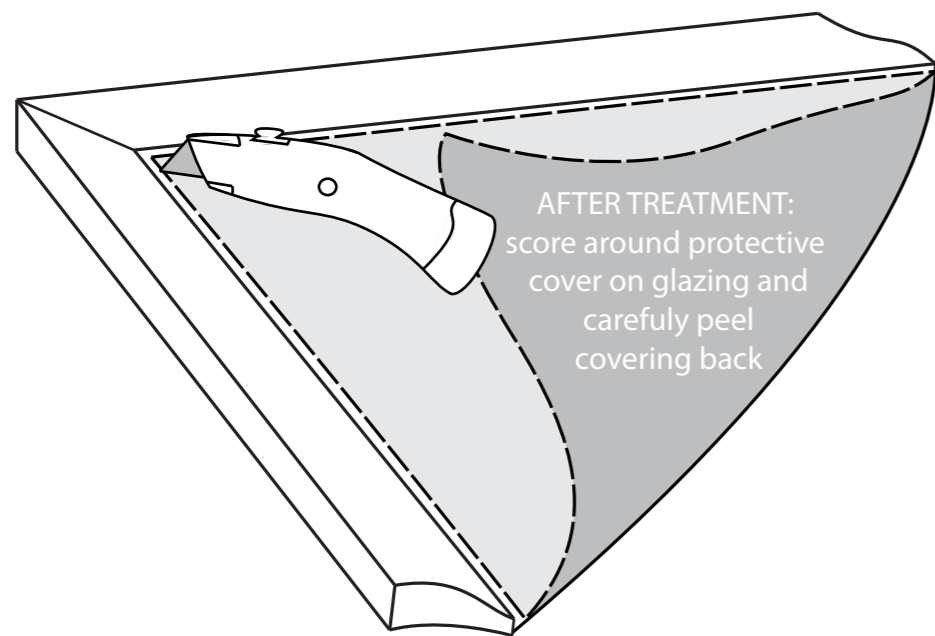

AFTER TREATMENT:
score around protective cover on glazing and carefully peel covering back