

Overlap Cladding

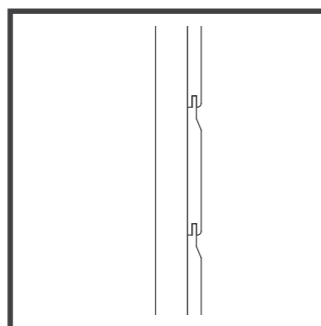

Shiplap Cladding

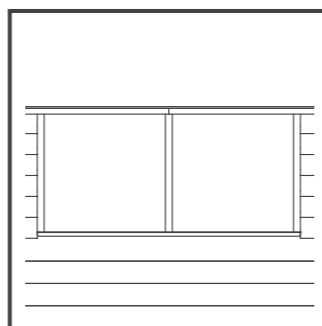

Fixed Windows

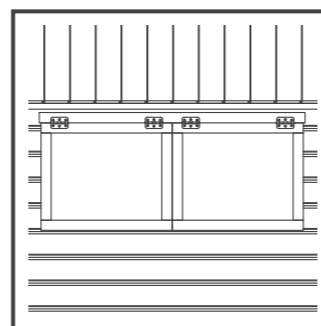

Opening Windows

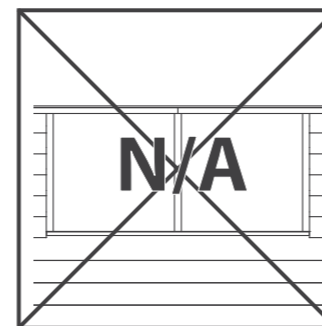

No Windows

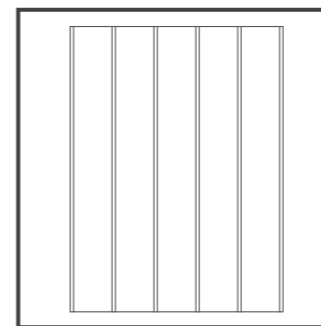

Solid Sheet Floor

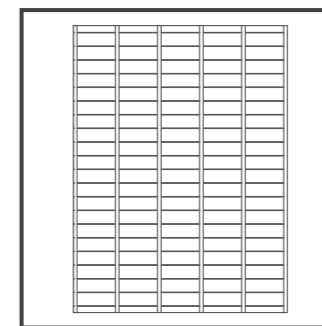

T&G Floor

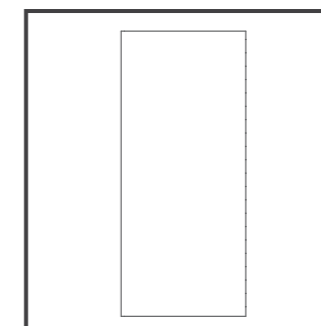

Solid Sheet Roof

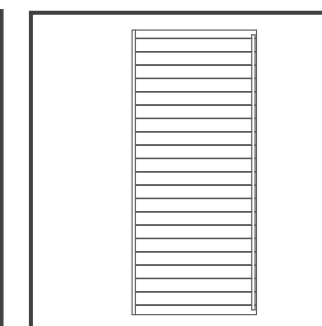

T&G Roof

01OVLPA0604SDFW-V1

6x4 Overlap apex shed with single door, fixed windows, solid sheet floor and roof.

01OVLPA0604SDFW-V1-NW

6x4 Overlap apex shed with single door, no windows, solid sheet floor and roof.

01OSBA0604SDFW-V1

6x4 Shiplap apex shed with single door, fixed windows, solid sheet floor and roof.

01OSBA0604SDFW-V1-NW

6x4 Shiplap apex shed with single door, no windows, solid sheet floor and roof.

01SHPA0604SDOW-V1

6x4 Shiplap apex shed with single door, opening windows, T&G floor and roof.

01SHPA0604SDOW-V1-NW

6x4 Shiplap apex shed with single door, no windows, T&G floor and roof.

BEFORE YOU START PLEASE READ INSTRUCTIONS CAREFULLY

- Check the pack and make sure you have all the parts listed.
- When you are ready to start, make sure you have the right tools at hand (**not supplied**) including a Phillips screwdriver, Stanley knife, wood saw, step ladder and drill with 2mm bit.
- Ensure there is plenty of space and a clean dry area for assembly.

TIMBER

As with all natural materials, timber can be affected during various weather conditions. For the duration of heavy or extended periods of rain, swelling of the wood panels may occur. Warping of the wood may also occur during excessive dry spells due to an interior moisture loss. Unfortunately, these processes cannot be avoided but can be helped. It is suggested that the outdoor building is sprayed with water during extended periods of warm sunshine and sheltered as much as possible during rain or snow.

Our buildings are pre treated with a water based treatment**; this only helps to protect the product during transit and for upto 3 months against mould. To validate your guarantee and ensure longevity of the product, it is ESSENTIAL the building is treated with a wood preserver within the first three months of assembly and thereafter in accordance with the manufactures recommendations. Care must be taken to ensure the product is placed on a suitable base.

BUILDING A BASE

When thinking about where the building and base is going to be constructed: Ensure that there will be access to all sides for maintenance work and annual treatment.

Ensure the base is level and is built on firm ground, to prevent distortion. Refer to diagrams for the base dimensions, The base should be slightly smaller than the external measurement of the building, i.e. The cladding should overlap the base, creating a run off for water. It is also recommended that the floor be at least 25mm above the surrounding ground level to avoid flooding.

TYPES OF BASE

- Concrete 75mm laid on top of 75mm hard-core.
- Slabs laid on 50mm of sharp sand.

Whilst all products manufactured are made to the highest standards of Safety and in the case of childrens products independently tested to EN71 level, we cannot accept responsibility for your safety whilst erecting or using this product.



x2

All building's should be erected by two adults

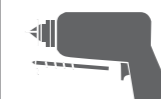

2mm Drill bit

For ease of assembly, you must pilot drill all screw holes and ensure all screw heads are countersunk.



Winter = High Moisture = Expansion
Summer = Low Moisture = Contraction



CAUTION

Every effort has been made during the manufacturing process to eliminate the prospect of splinters on rough surfaces of the timber. You are strongly advised to wear gloves when working with or handling rough sawn timber.

For Assistance Please Contact Customer Care on 01636 880514

****Protim Fentex E5****

Biocidal Product Regulation (EU 528/2012) Article 58 Information
Protim Fentex E2 preserved wood is a "treated article" which incorporates biocidal products. Wood correctly preserved with Protim Fentex E2 is protected against mould in storage. Contains: IPBC (3-iodo-2-propynyl-N-butyl carbamate) and propiconazole.

Wear gloves when handling freshly treated wood.
Avoid breathing dust when cutting treated or untreated wood.
Dispose of off-cuts responsibly – do not burn.

Overall Dimensions:

Length = 1794mm
Width = 1199mm
Height = 1863mm

Base Dimensions:

Length = 1753mm
Width = 1175mm

Before assembly
please make sure you have a
suitable base ready to erect your
building



MADE IN GREAT BRITAIN

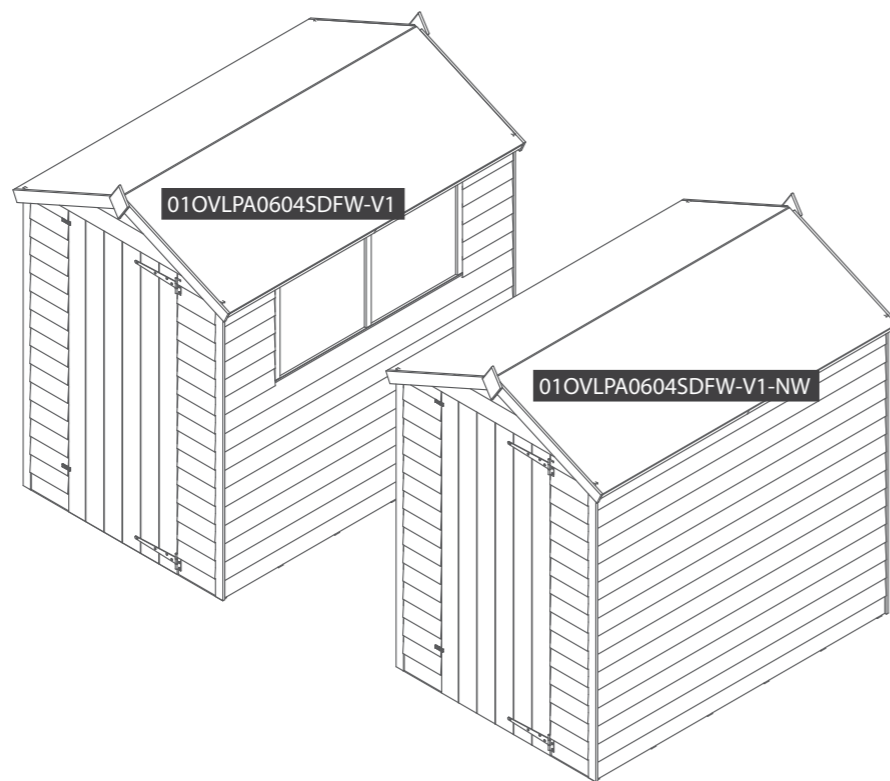

Pre Assembly

Remove transportation
blocks from the bottom
of each panel before
beginning assembly. Each
Panel should have two

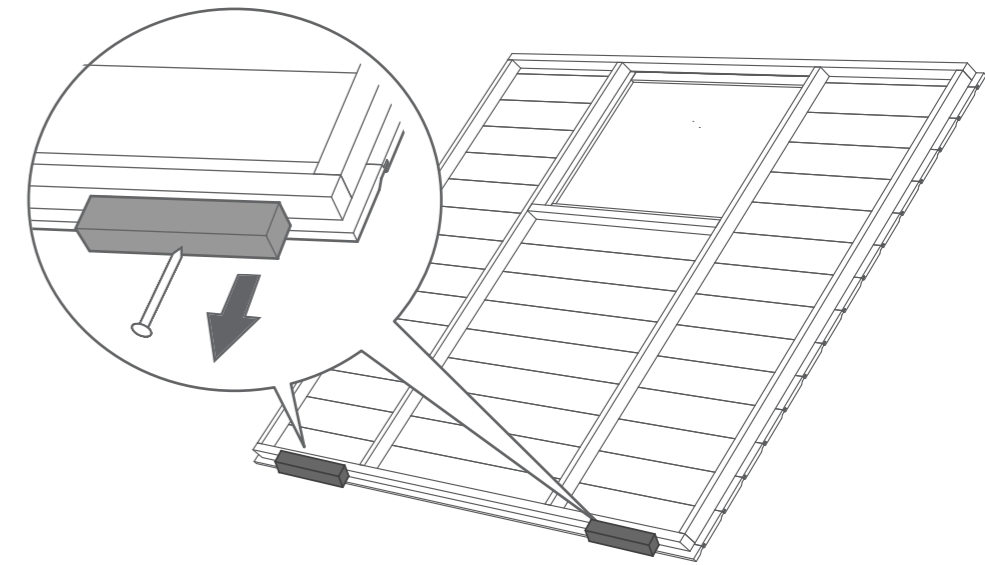

Building content

- 1 Door Gable
- 2 Back Gable
- 3 Plain Side
Qty 2 -NW only
- 4 Window Panel
FW-V1 ONLY
- 5 Floor
- 6 Roof
x2
- 7 Door
x2
- 8 Fascia 694mm x4
- 9 Fixed Window Strip 546mm x5 FW-V1 ONLY
- 10 Cover Trims 1575mm x4
- 11 Door Beading Strip 1530mm x2
- 12 Ridge Bar 1708mm
- 13 Eaves Frame 897mm x4
- 14 Finial x2
- 15 T Hinge
Qty 2
- 16 Plastic Window Cill
FW-V1 ONLY
- 17 Turn Button
Qty 2
- 18 Felt
- 19 Styrene Qty 2
FW-V1 ONLY
- 20 L-Bracket
Qty 2

Fix the T Hinges onto the
doors and door frame as
shown. Ensure that the
screws go through the
cladding and into the
framing behind.

14x30mm screws

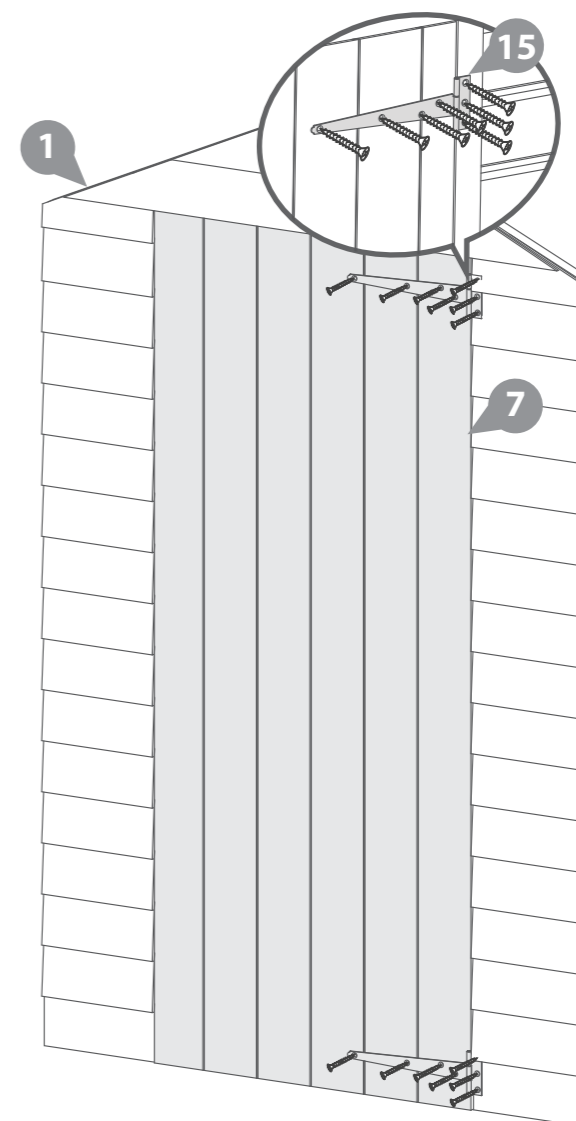

Nail Bag	
	Felt Tacks x 72
	20mm Screw x 8
	30mm Black Screw x 2
	30mm Screw x 62
	40mm Screw x 48
	50mm Screw x 41

Step 1

Place the floor on a firm and level base, ensure the base has suitable drainage free from areas where standing water can collect. See the front page for base requirements.

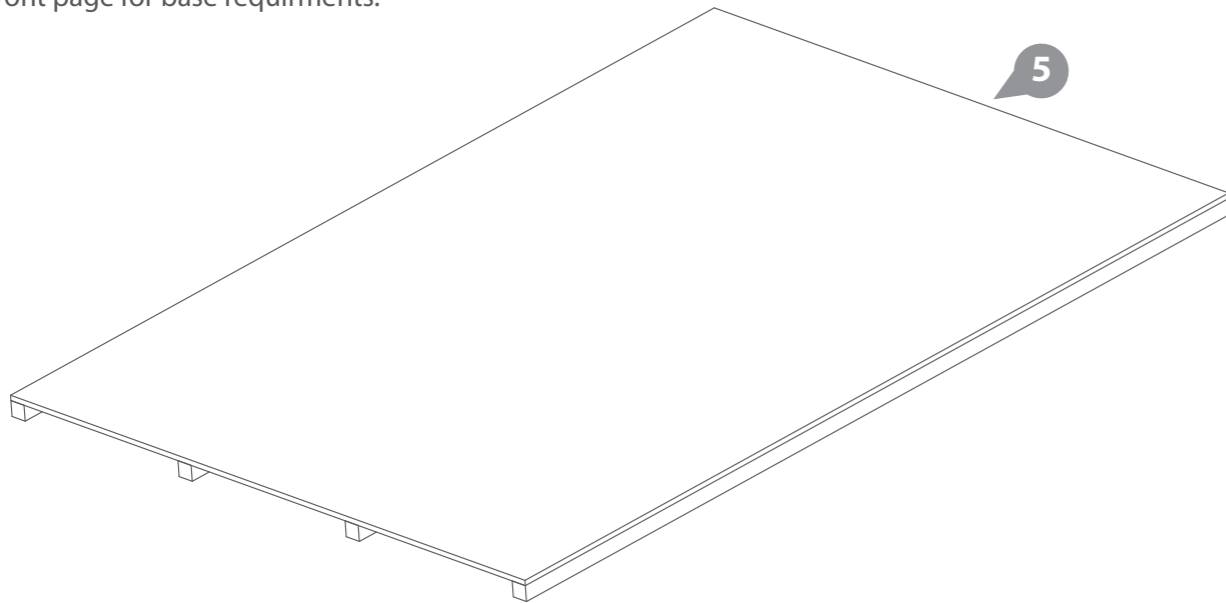

Step 2

Fix the corners with 50mm screws as shown in diagram.

Do not secure the building to the floor until the roof is fitted. Fix the panels onto the floor using 50mm screws in alignment with the floor joists

Position the panels so there is equal spacing between the floor and cladding on all 4 sides

3x50mm Screws

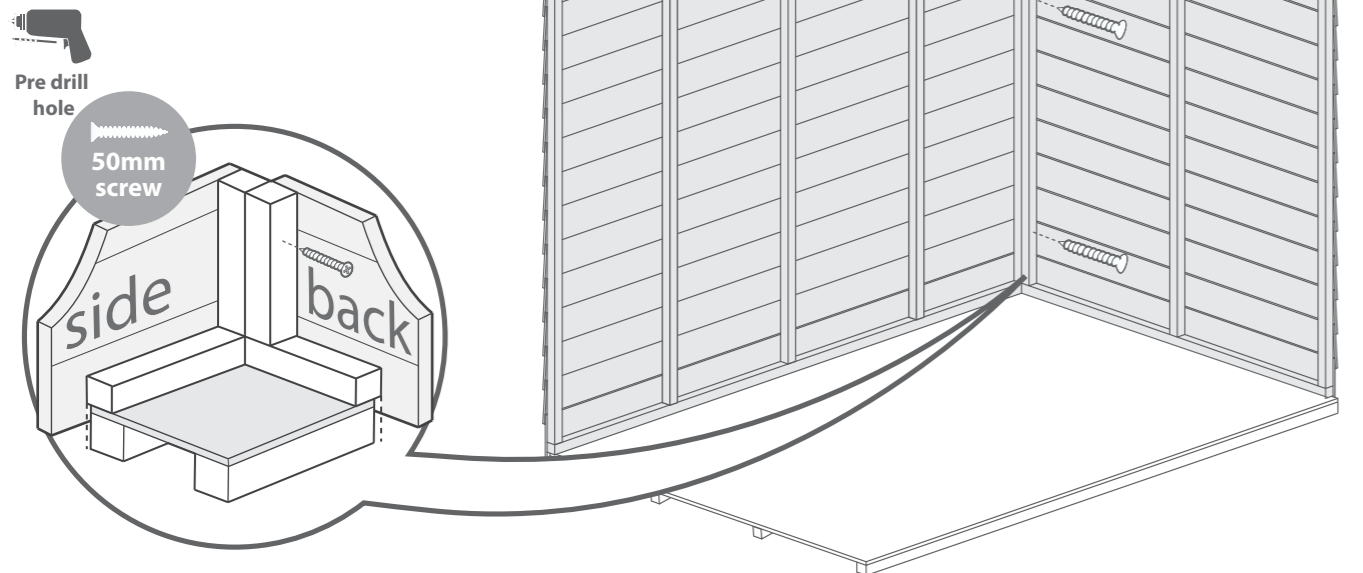

Step 3

Fix the corners with 50mm screws as shown in diagram.

9x50mm Screws

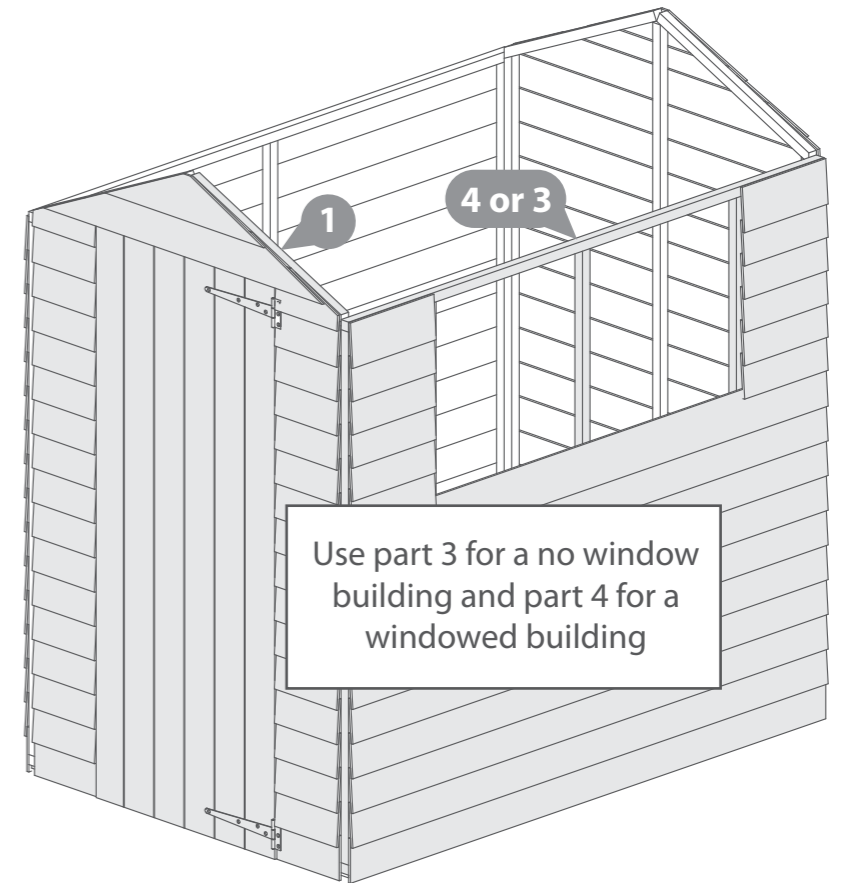
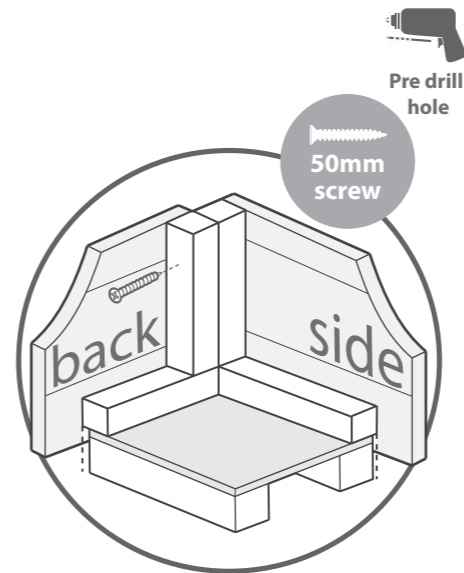

Step 4

Place the ridge bar in between the front and back gables. Ensure the top corners of the ridge bar sit flush with the top points of the door gable. Fix the ridge bar to the gable using one L bracket for each end.

Fix with 4x20mm screws each

8x20mm Screws

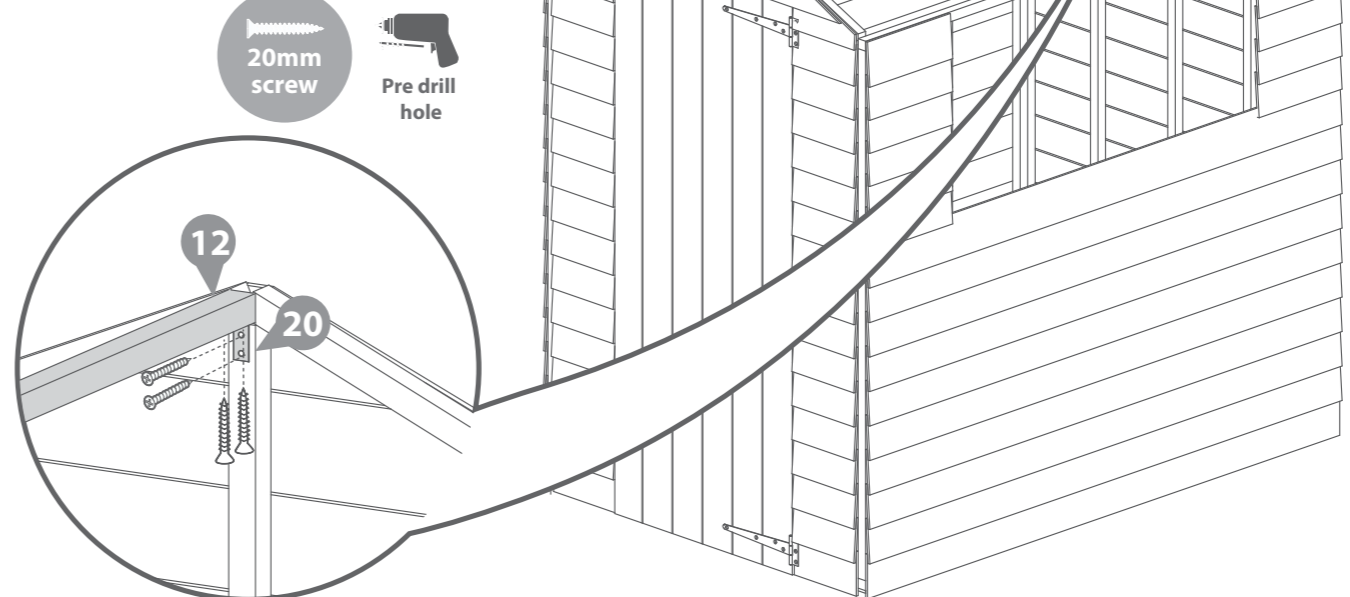

Step 5

Fix two eaves frames to each roof sheet using 3x30mm screws per eave.

Fix the roof sheets to the roof ensuring they come together at the top using 40mm screws directly through the roof sheet at the top. Make sure to attach the roofs to the ridge bar.

12x 30mm Screws
28x 40mm Screws

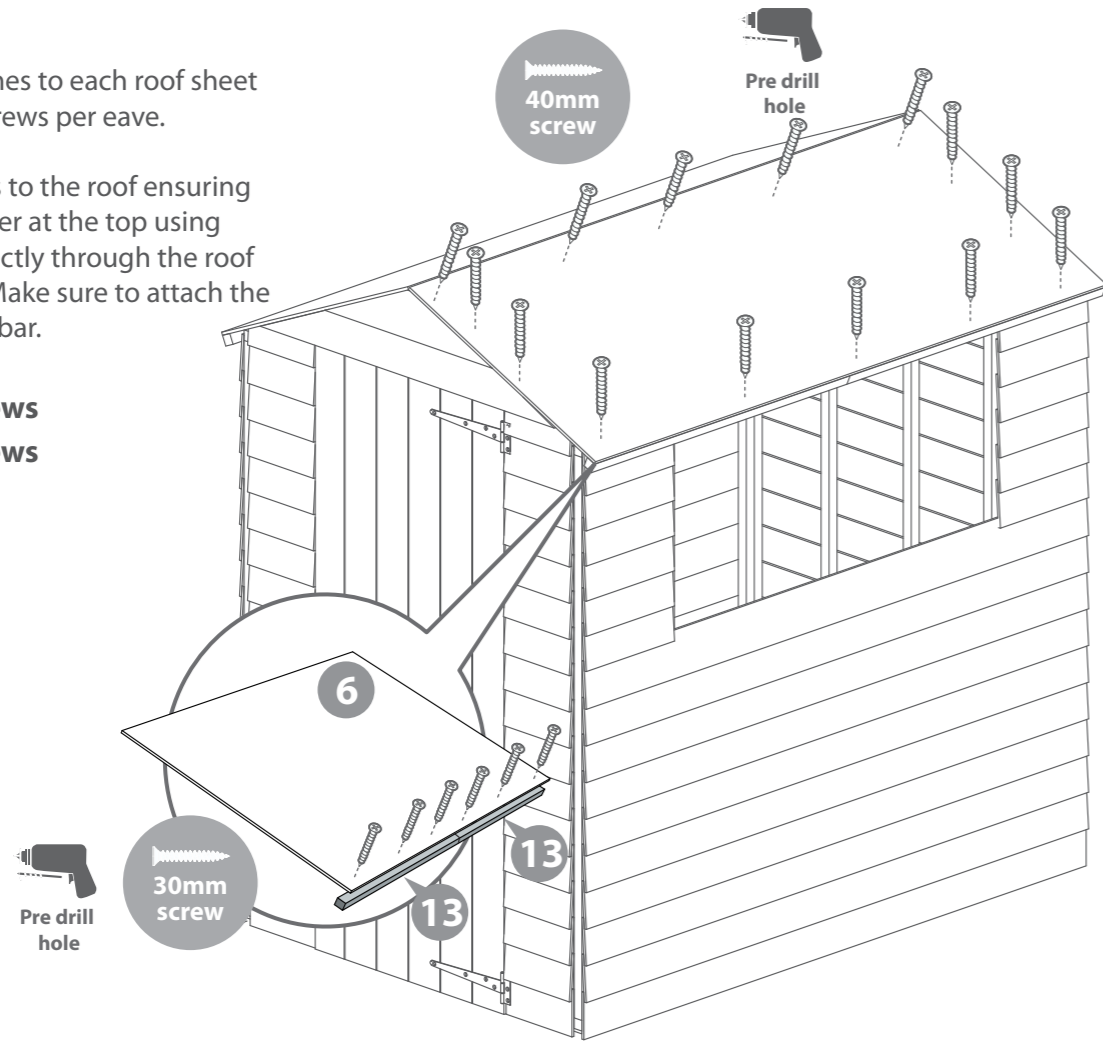

Step 6

b Once the roof is fixed attach the building to the floor with 50 mm screws.

16x 50mm Screws

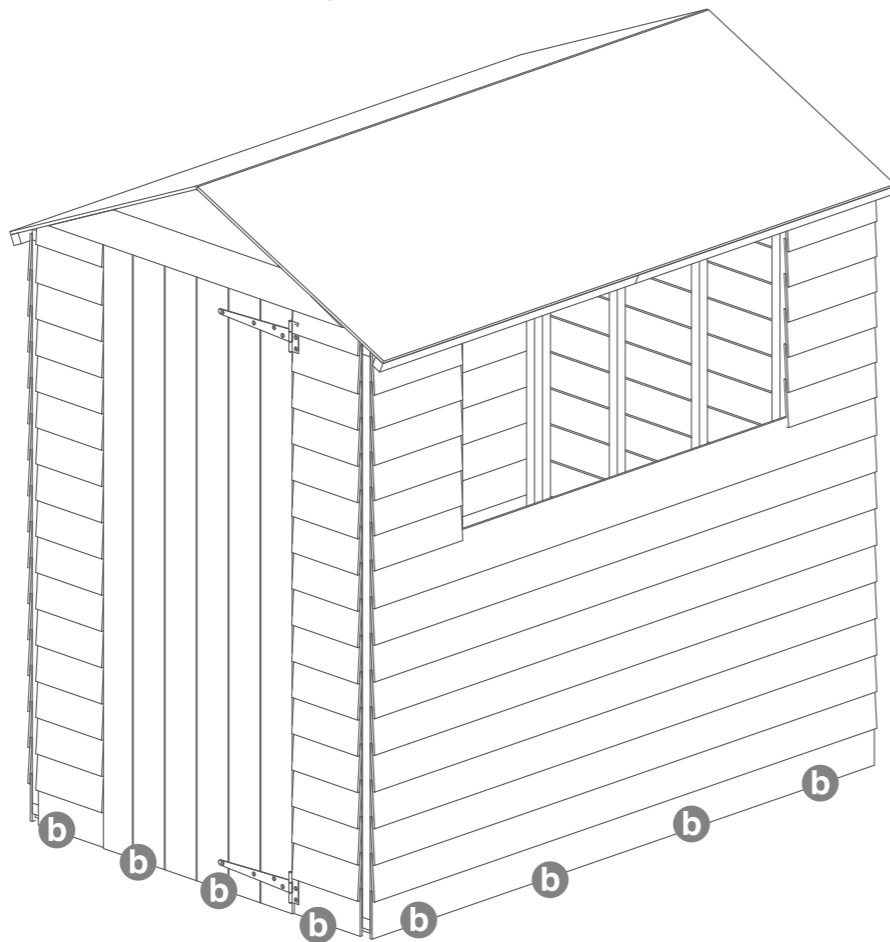
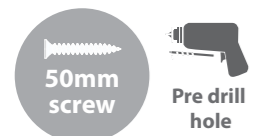

Step 7

Cut the felt into 2 sheets at 1894mm and fix onto the roof using felt tacks as shown in diagram ensuring there is 50mm overhang around the sides.

72x Tacks

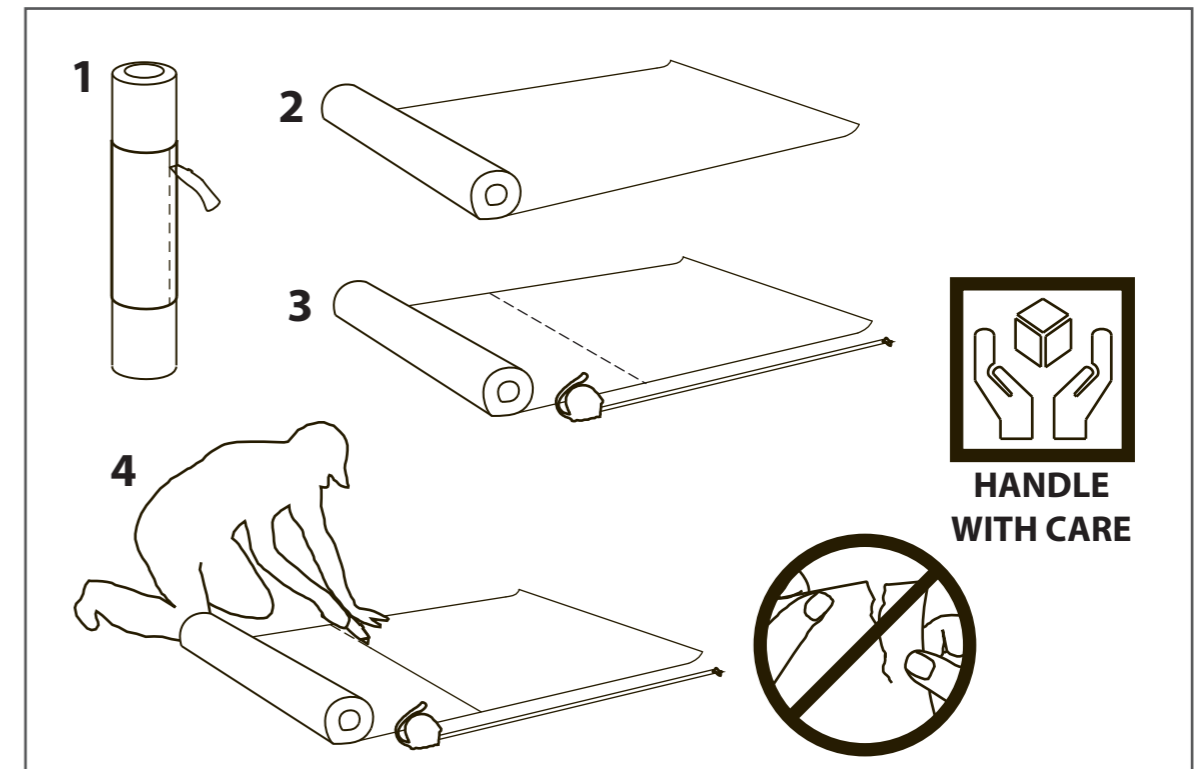
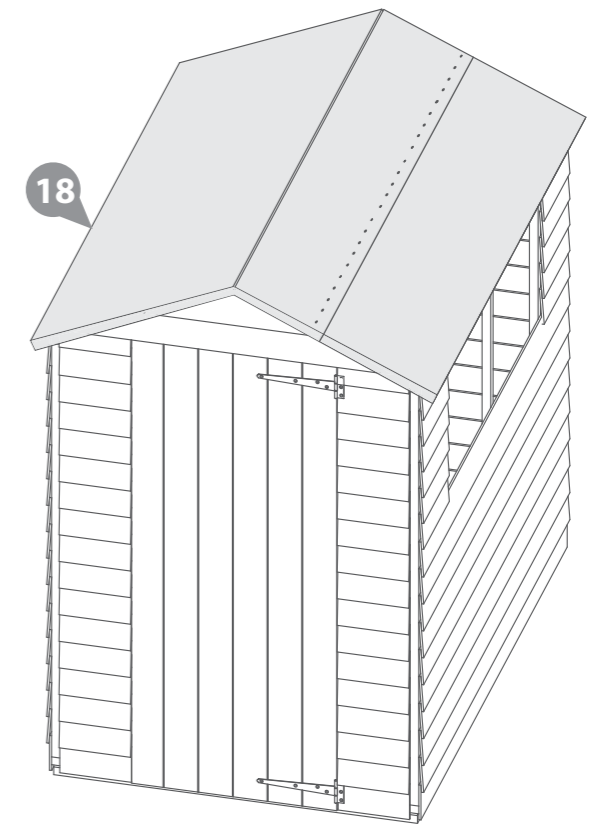
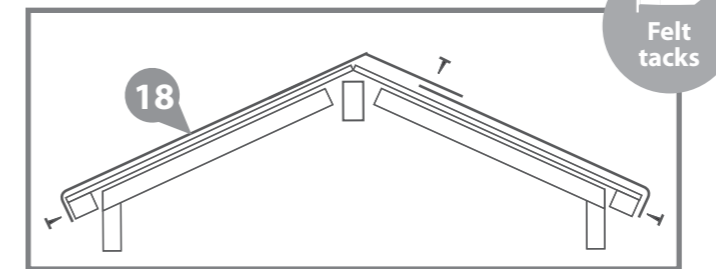
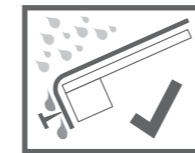

Step 8

Fit the Cover Trims to the front and back of the building as shown in the illustration using 30mm screws. Trim the length of the cover trims to the required size before fitting if necessary. Pre drill to avoid splitting.

12x30mm Screws

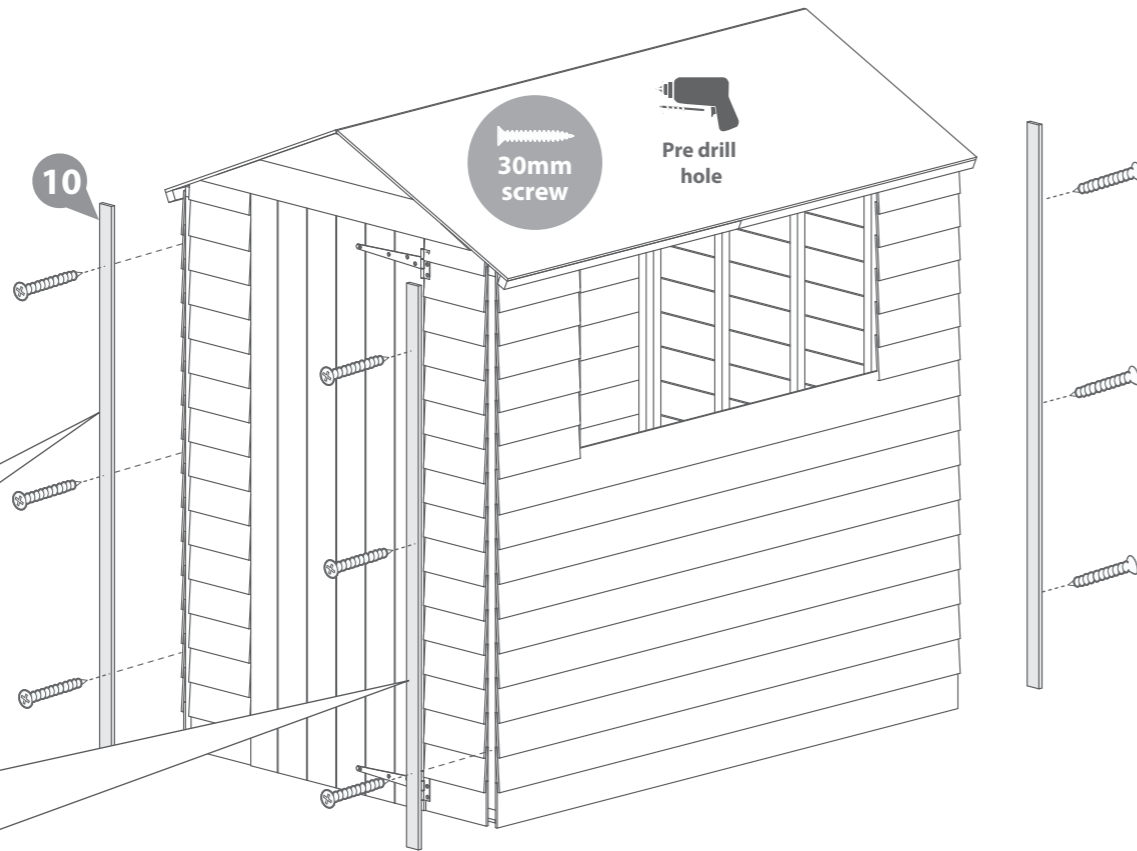
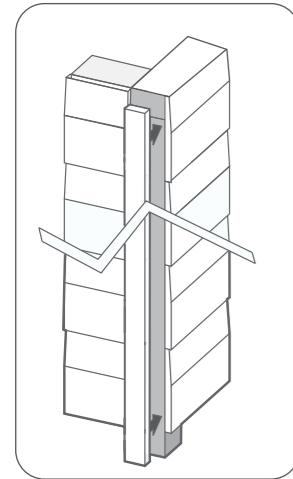

Step 9

Attach the fascias to the roof leaving a slight overhang at the top.

Fit the fascias to the roof over the felt and secure in place with 40mm screws as shown. Pre drill to avoid splitting.

16x40mm Screws

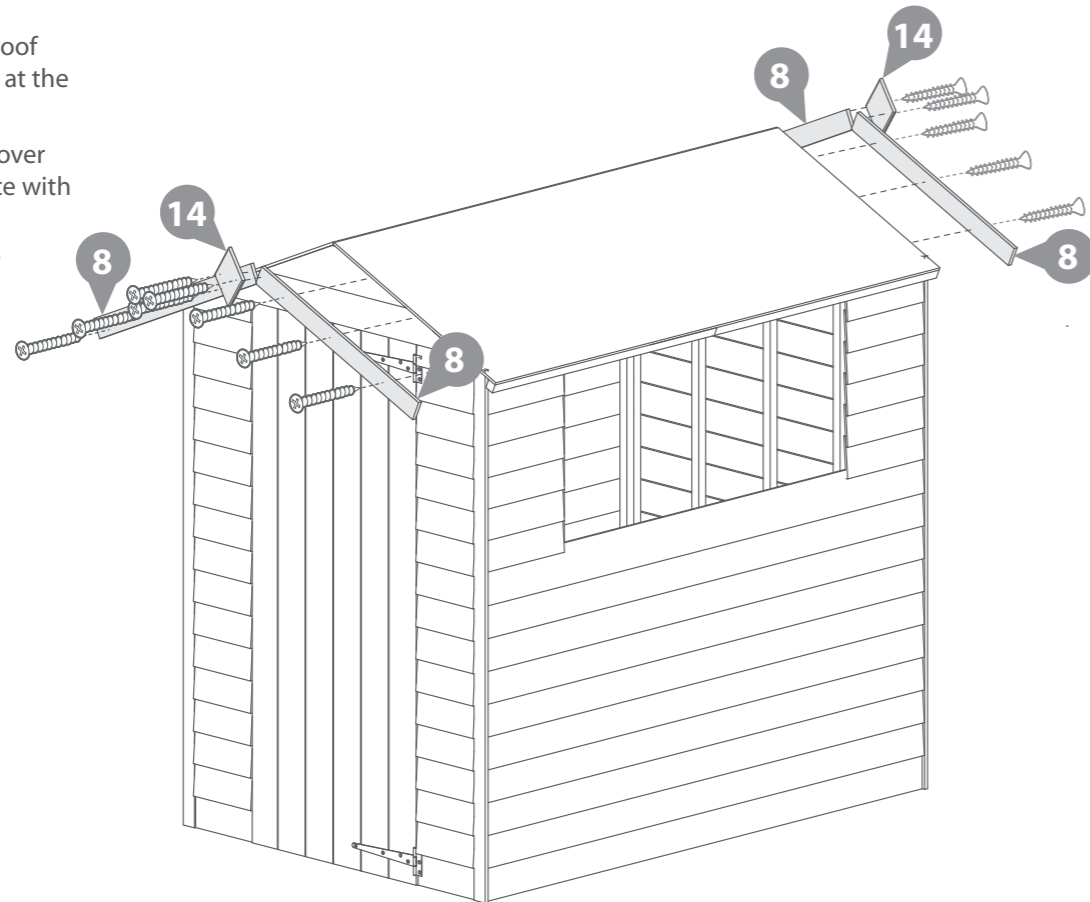
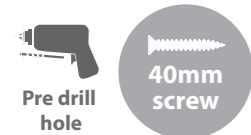

Step 10

For the no window version go to step 11

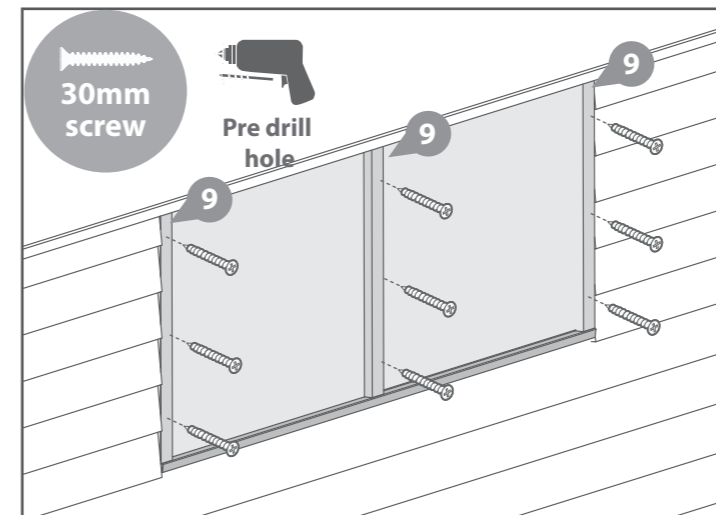
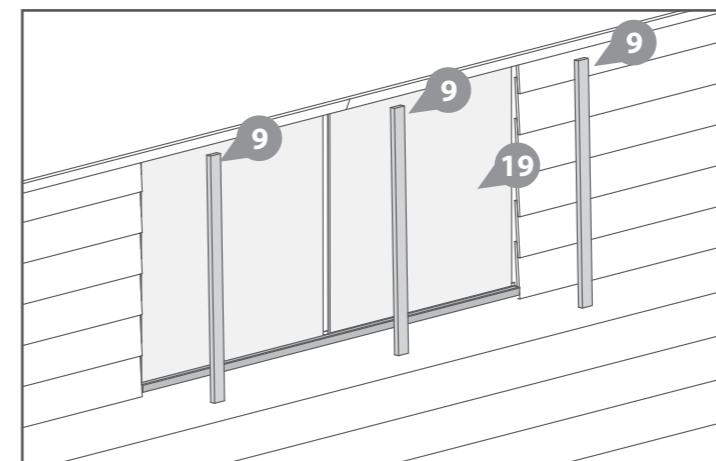
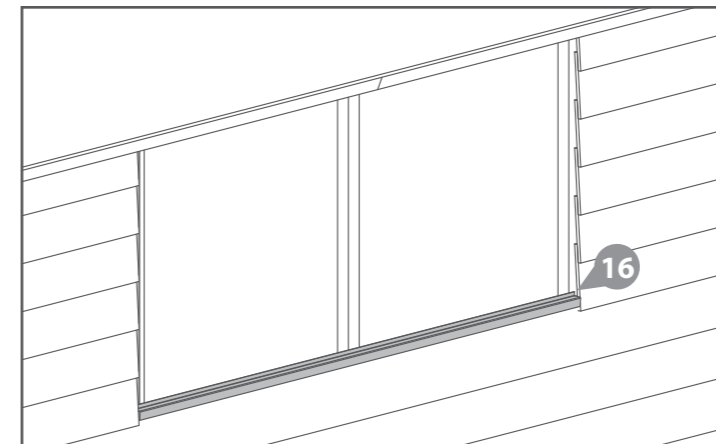
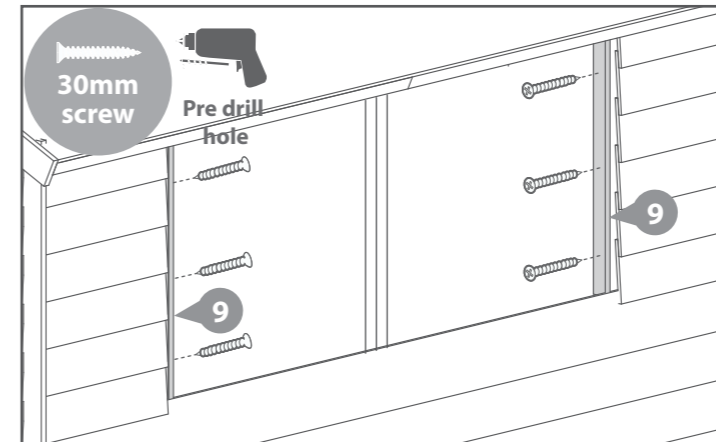

Fix the window strips to the two pieces of framing that sit alongside the outside edges of the window with 3x30mm screws for each strip.

6x30mm Screws

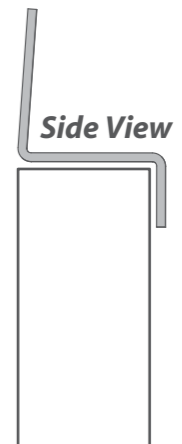

Side View

Place the plastic window cill onto the Window Panel in the same way as shown on both diagrams to the left.

Fit the styrene sheets on top of the window cill.

When positioning the styrene sheets ensure there is an equal distance between them and at either side of the windows.

Attach the three window strips at either side of the windows using 3x30mm screws each. Make sure the screws enter the framing in the window panel and not the styrene.

9x30mm Screws

Step 11



Use 4x30mm Screws to fix each beading strip onto the door gable. Ensure that the screw is parallel with the door frame when fixing the strip to the door gable as shown in the close up view.

8x30mm Screws

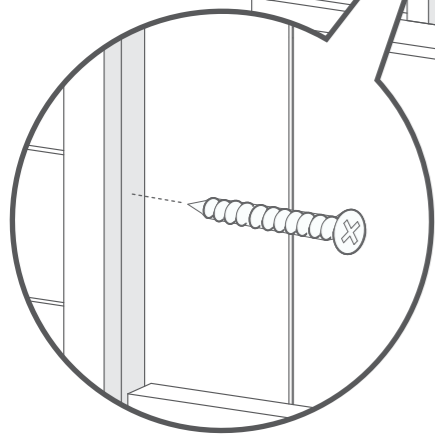

Step 12

Fix the Turn Button onto the door gable using 1x30mm black screw for each one.

2x 30mm Black Screw

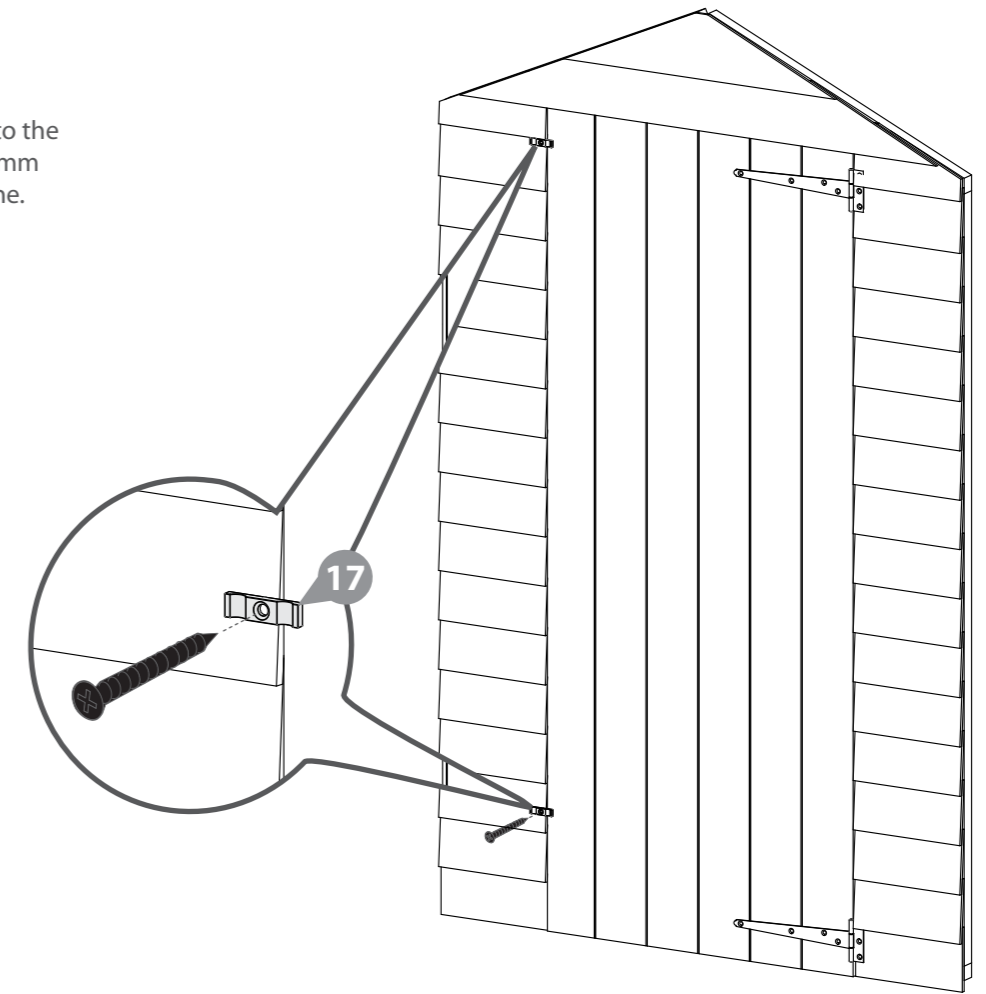
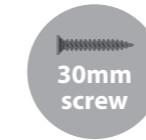

It is ESSENTIAL that you apply wood treatment immediately after the building has been assembled.

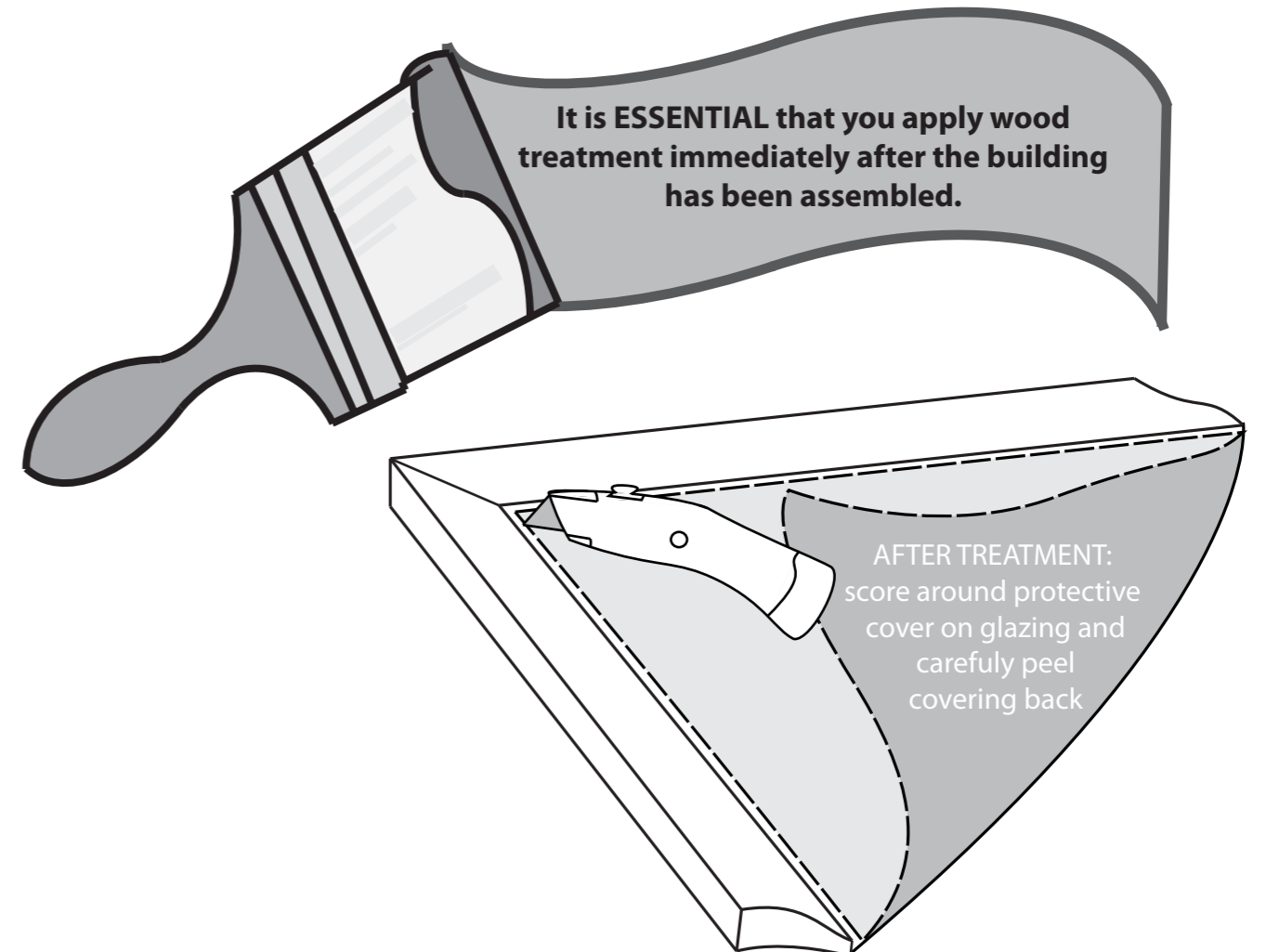

AFTER TREATMENT:
score around protective cover on glazing and carefully peel covering back