

**Overlap Cladding**

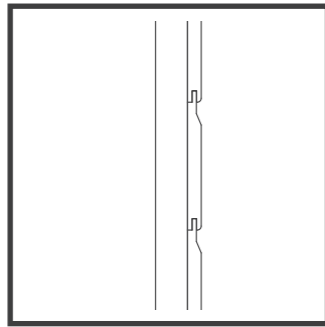

**Shiplap Cladding**

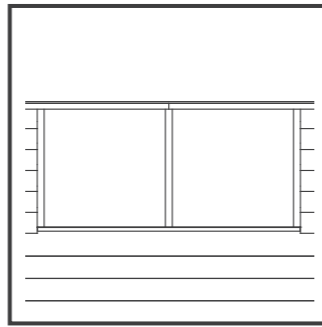

**Fixed Windows**

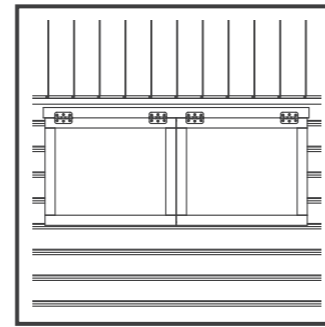

**Opening Windows**

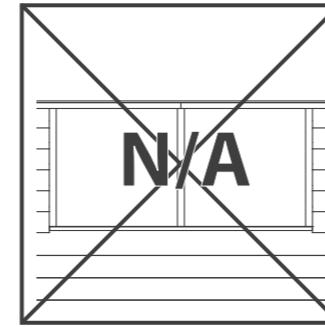

**No Windows**

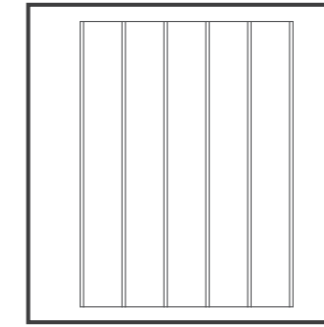

**Solid Sheet Floor**

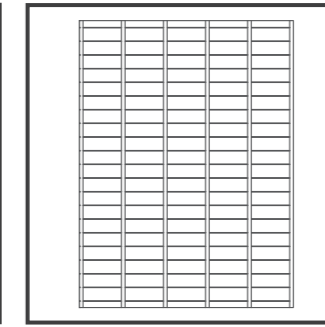

**T&G Floor**

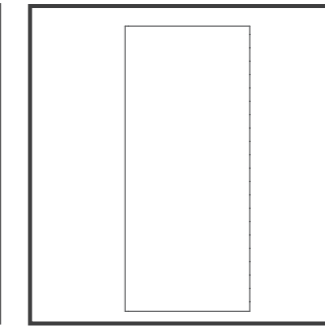

**Solid Sheet Roof**

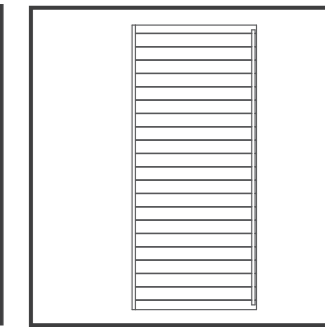

**T&G Roof**

**03BRN0705-V3**

**7x5 Bournemouth Summerhouse**

**03BRN0707-V3**

**7x7 Bournemouth Summerhouse with Veranda**

**03BRN0807-V3**

**8x7 Bournemouth Summerhouse with Veranda**

**BEFORE YOU START PLEASE READ INSTRUCTIONS CAREFULLY**

- Check the pack and make sure you have all the parts listed.
- When you are ready to start, make sure you have the right tools at hand (**not supplied**) including a Phillips screwdriver, Stanley knife, wood saw, step ladder and drill with 2mm bit.
- Ensure there is plenty of space and a clean dry area for assembly.

The images used throughout the instruction manual are generic and for illustration purposes only; they may vary dependant on your actual product. It is strongly advised they are read and understood before attempting installation.

**TIMBER**

As with all natural materials, timber can be affected during various weather conditions. For the duration of heavy or extended periods of rain, swelling of the wood panels may occur. Warping of the wood may also occur during excessive dry spells due to an interior moisture loss. Unfortunately, these processes cannot be avoided but can be helped. It is suggested that the outdoor building is sprayed with water during extended periods of warm sunshine and sheltered as much as possible during rain or snow.

Our buildings are coated with a water based high quality colorant; this only helps to protect the product during transit and for up to 3 months against mould. To validate your guarantee and ensure longevity of the product, it is ESSENTIAL the building is treated with a wood preserver within the first three months of assembly and thereafter in accordance with the manufactures recommendations. Care must be taken to ensure the product is placed on a suitable base

**BUILDING A BASE**

When thinking about where the building and base is going to be constructed: Ensure that there will be access to all sides for maintenance work and annual treatment. The base is level and is built on firm ground, to prevent distortion. Refer to diagrams for the base dimensions, The base should be slightly smaller than the external measurement of the building, i.e. The cladding should overlap the base, creating a run off for water. It is also recommended that the floor be at least 25mm above the surrounding ground level to avoid flooding.

**TYPES OF BASE**

- Concrete 75mm laid on top of 75mm hard-core.
- Slabs laid on 50mm of sharp sand.



All buildings should be erected by two adults



**2mm Drill bit**

For ease of assembly, it is advisable to pilot drill all screw holes and ensure all screw heads are countersunk.



Winter = High Moisture = Expansion  
Summer = Low Moisture = Contraction



**CAUTION**

Every effort has been made during the manufacturing process to eliminate the prospect of splinters on rough surfaces of the timber. You are strongly advised to wear gloves when working with or handling rough sawn timber.

**For Assistance Please  
Contact Customer Care on  
01636 880514**

Whilst all products manufactured are made to the highest standards of Safety and in the case of childrens products independently tested to EN71 level, we cannot accept responsibility for your safety whilst erecting or using this product.

### Overall Dimensions:

Length = 1744mm  
 Width = 2281mm  
 Height = 2191mm

### Base Dimensions:

Length = 1448mm  
 Width = 2082mm

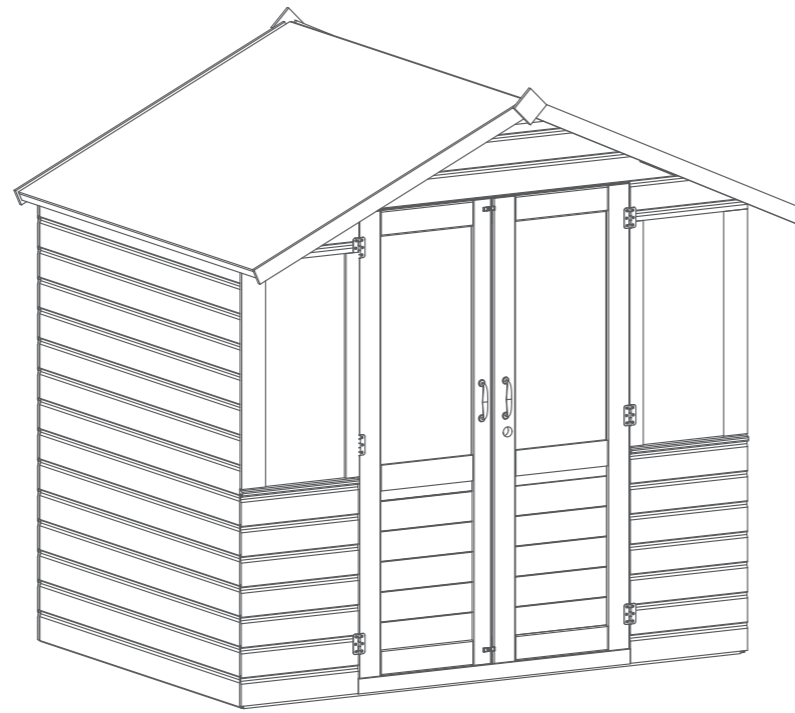

### Contents

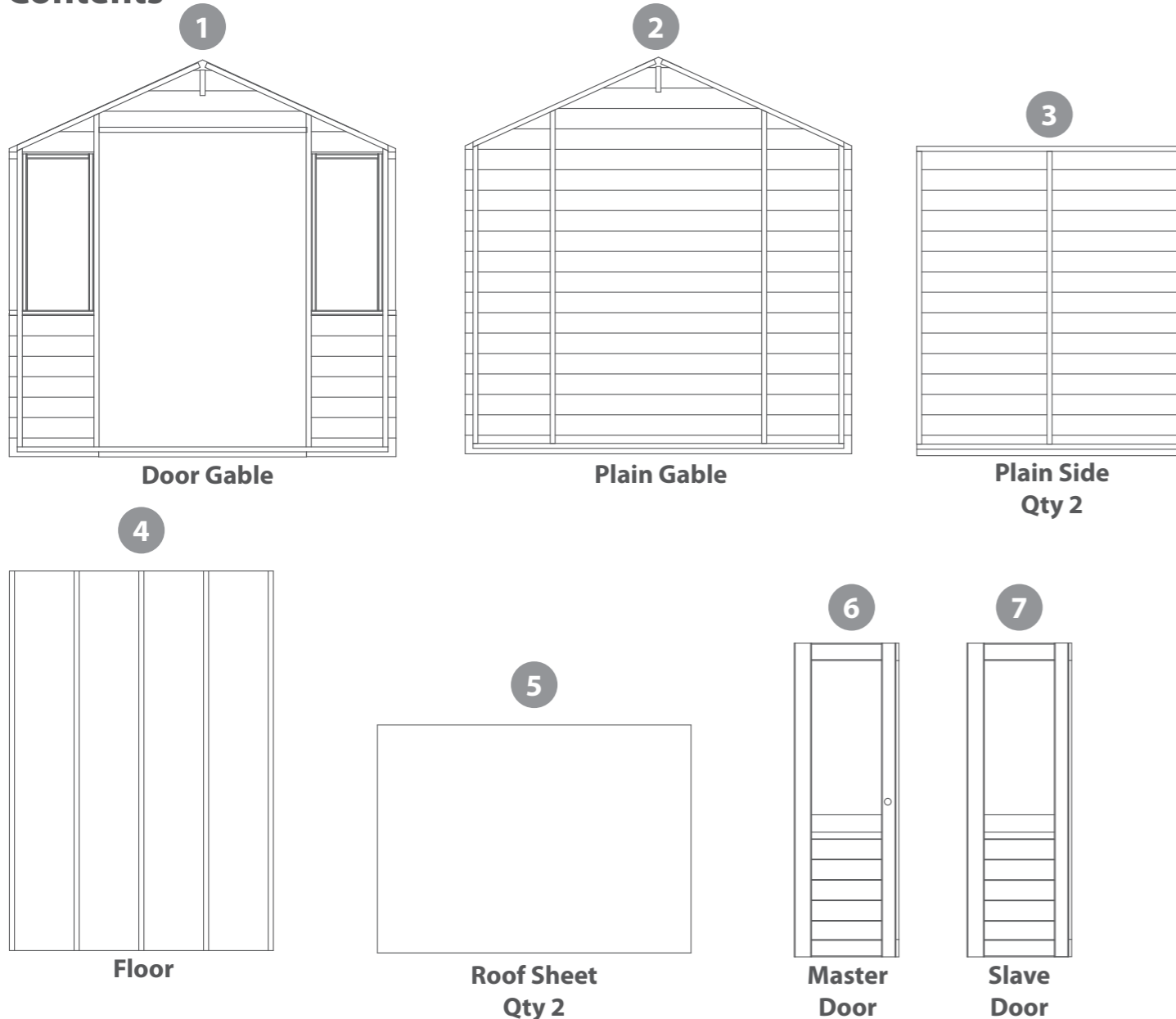

### Fixing Kit

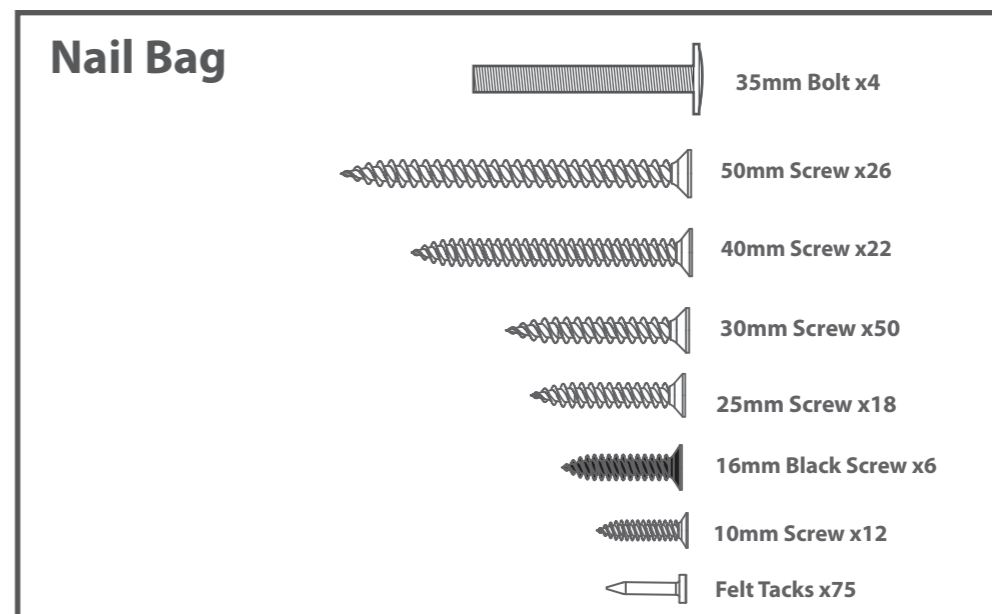
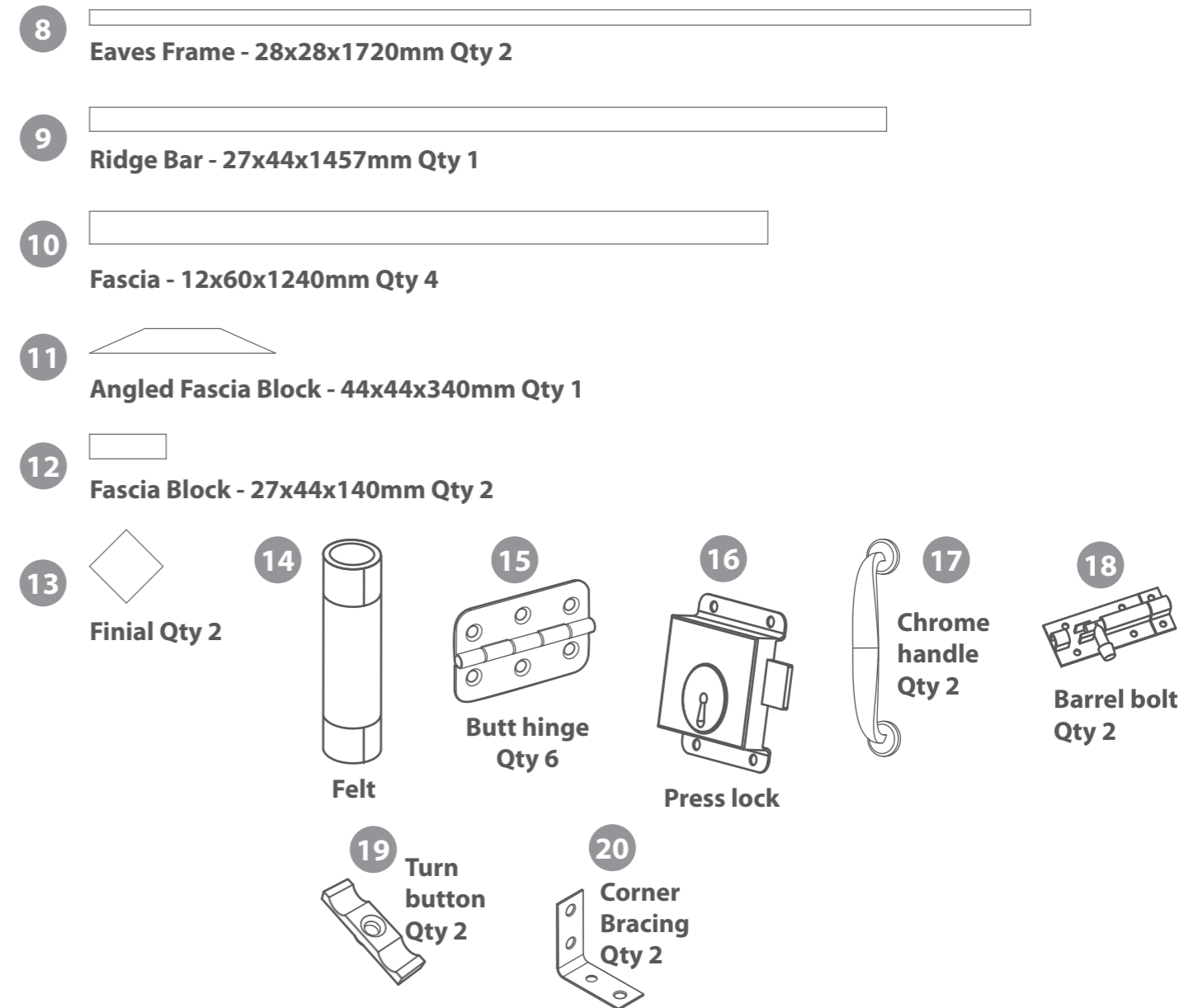

## Step 1

Remove transportation blocks from the bottom of each panel before beginning assembly. Each Panel should have two.

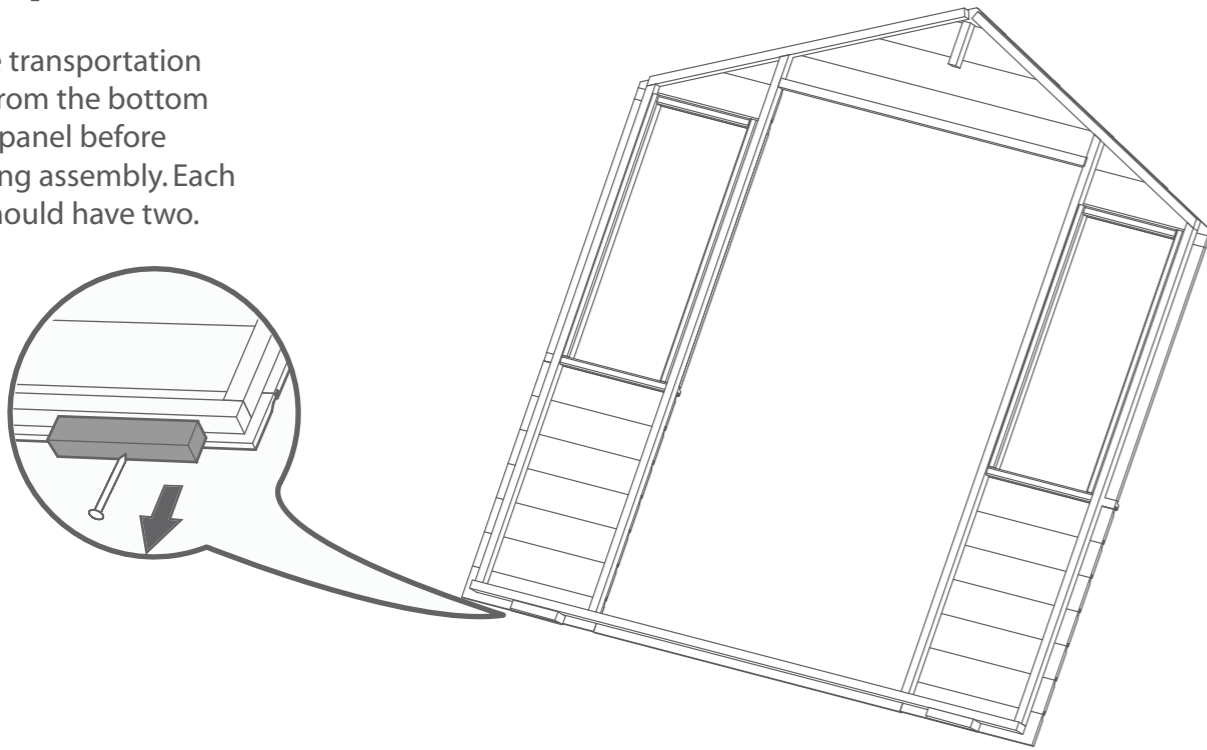

## Step 3

Place the floor on a firm and level base, ensure the base has suitable drainage free from areas where standing water can collect. (See front page on base requirements).

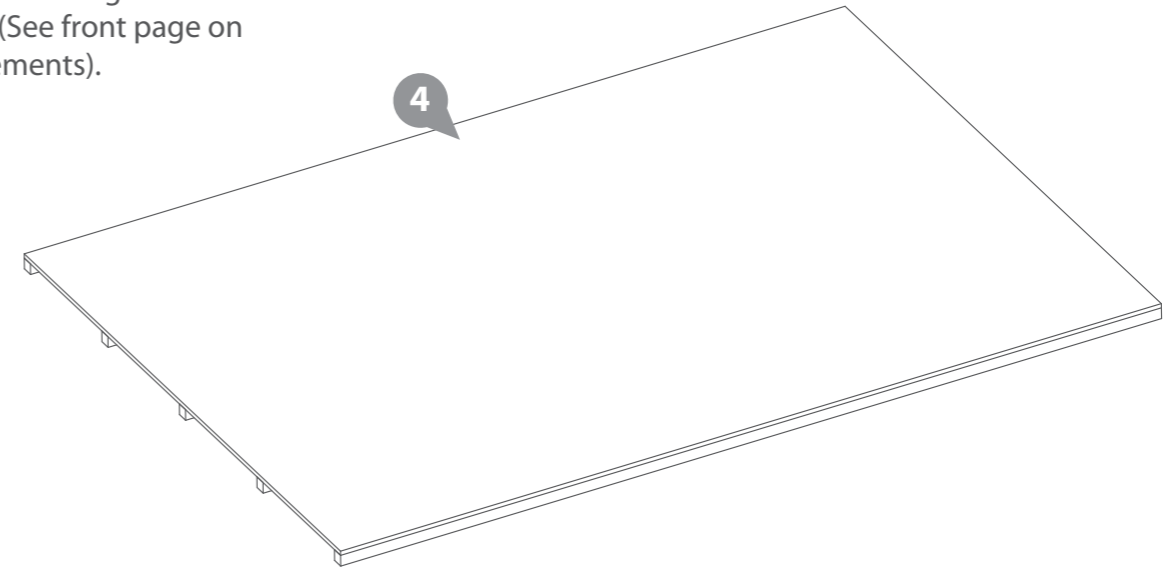

## Step 2

Lay the door gable on a flat surface and place both doors into the door aperture. Position the doors so that they are equally spaced within the opening.

Fix the butt hinge to the doors using 25mm screws. Ensuring the doors are positioned equally fix the hinges to the door panel using 30mm screws.

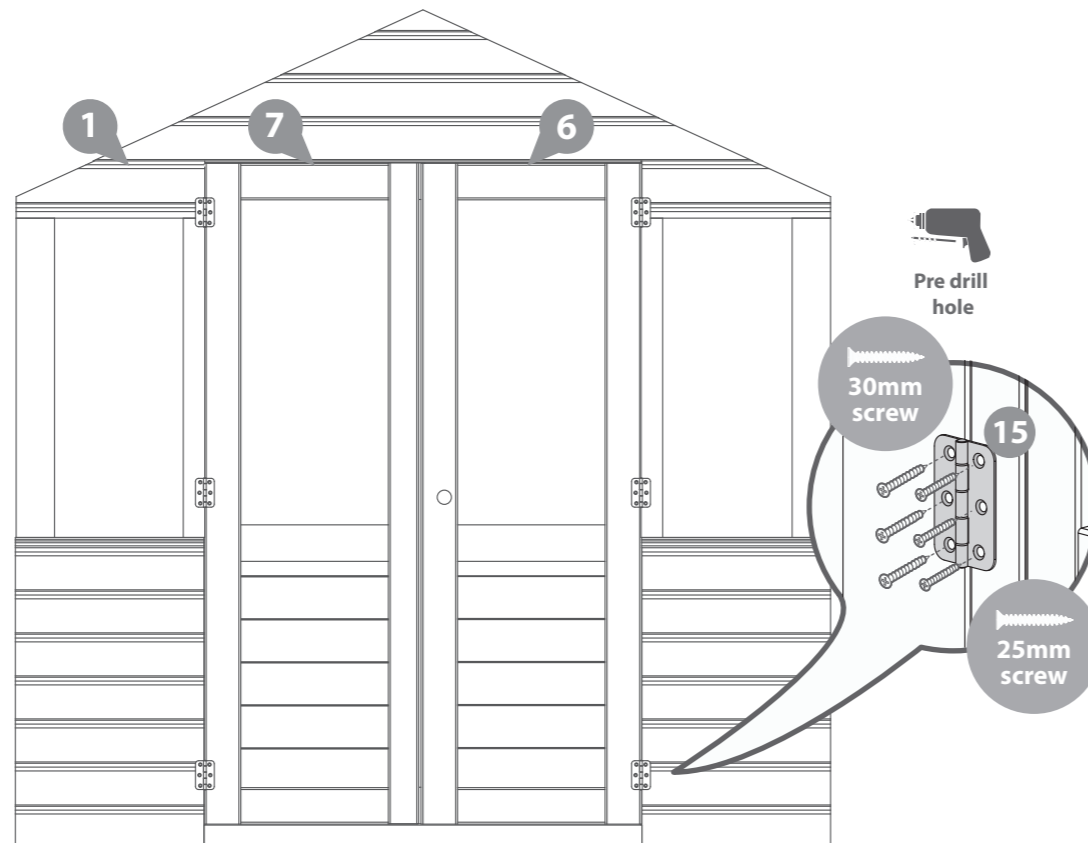

18x25mm Screws  
18x30mm Screws

## Step 4

**a** Fix the corner with 3x 50mm screw as shown in the diagram.

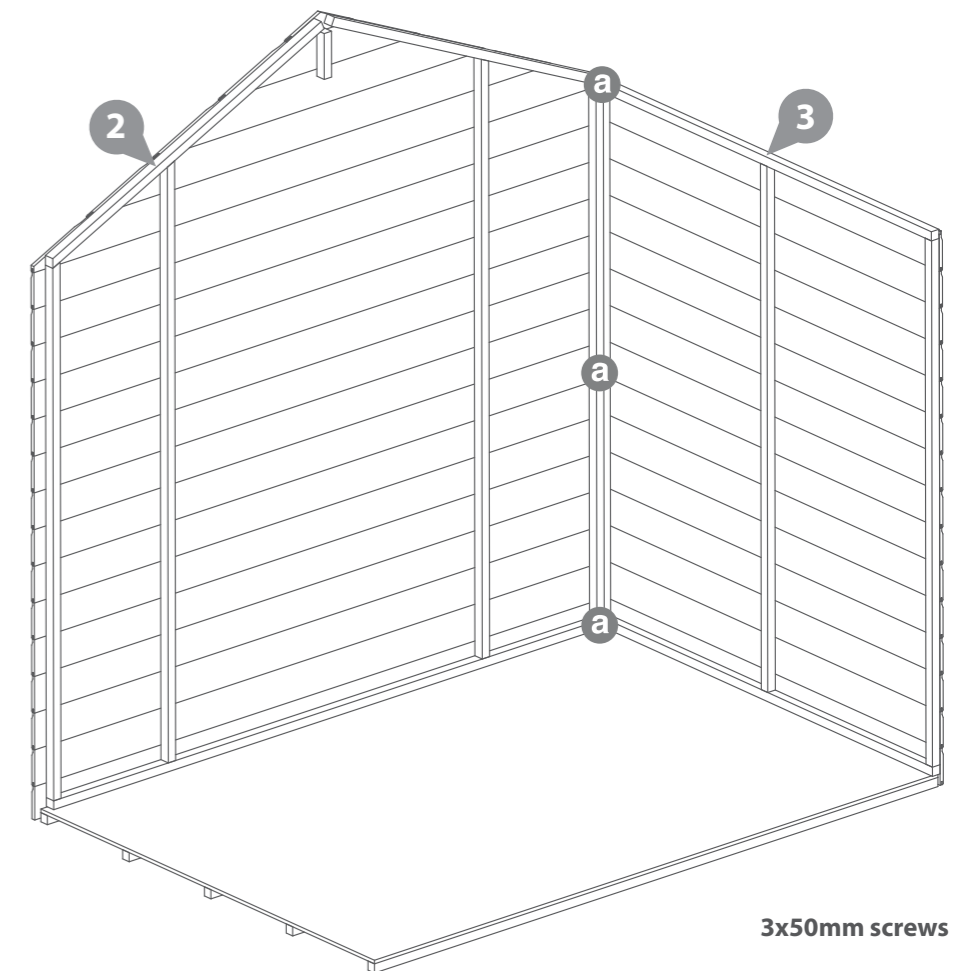
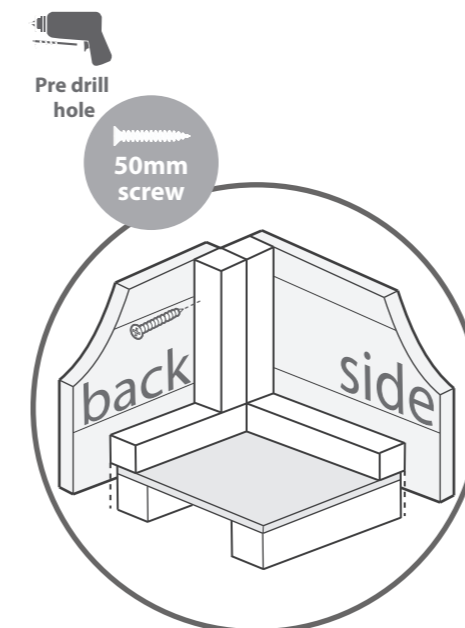

3x50mm screws

### Step 5

a Fix the corners with 3x 50mm screw as shown in the diagram.

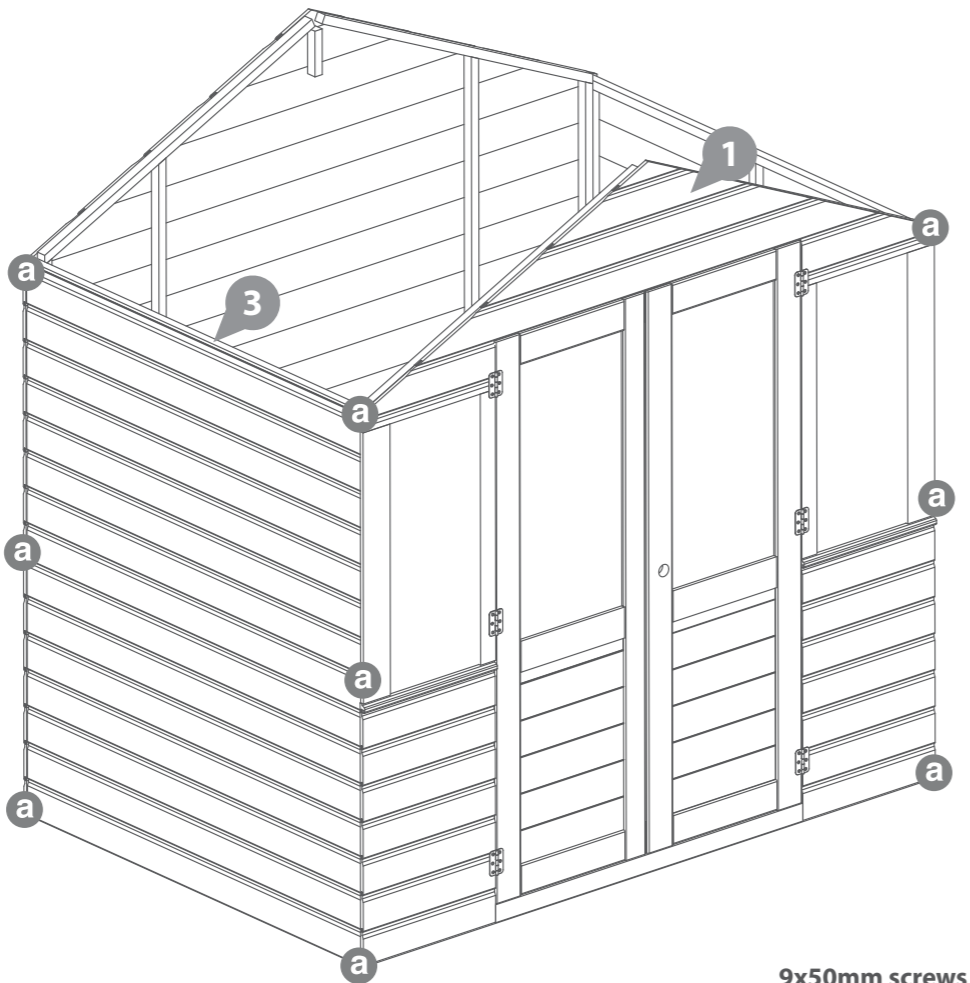
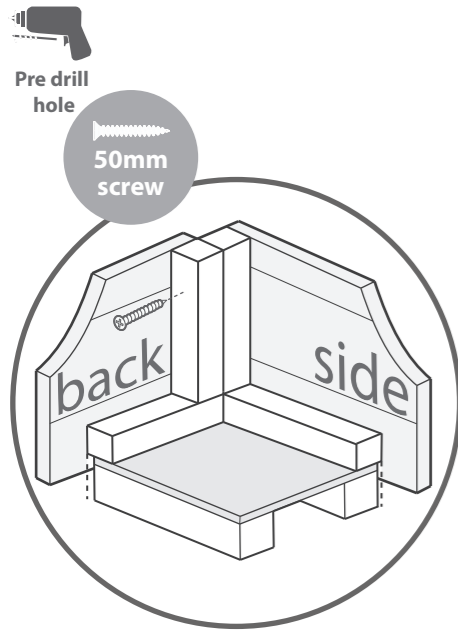

9x50mm screws

### Step 7

Fix a roof eave to the edge of the roof sheet using 30mm screws. Do this for both roof eaves and roof sheets.

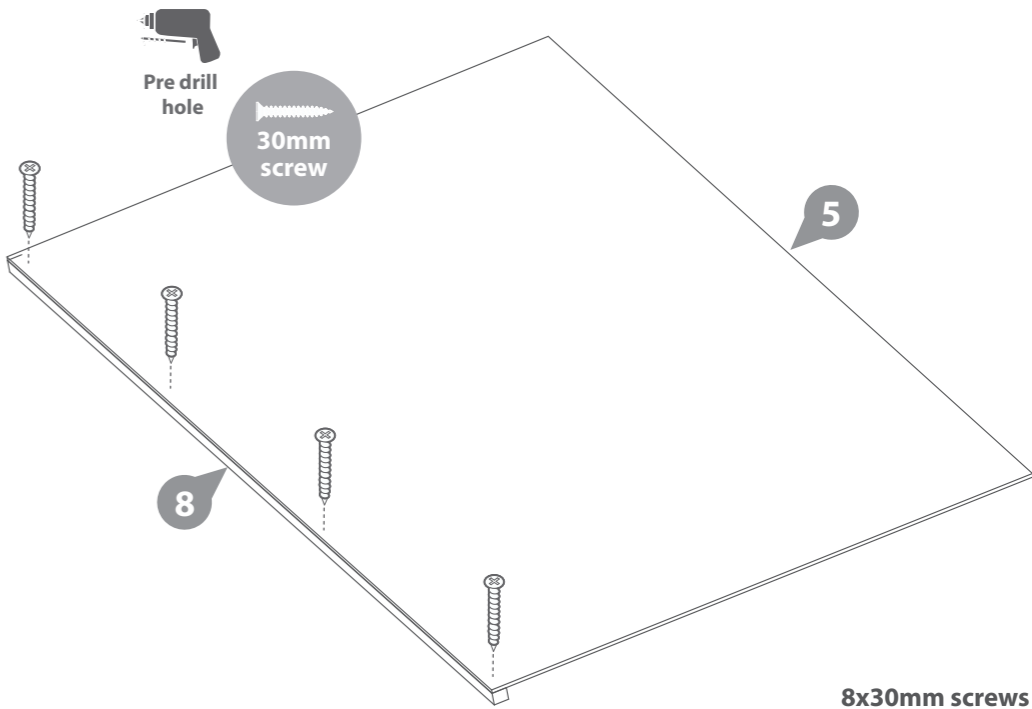

8x30mm screws

### Step 8

Fix the roof sheets on either side of the building as shown in the diagram.

Fix the panels into position using 30mm screws from the top of the panel straight into the framing and ridge bar.

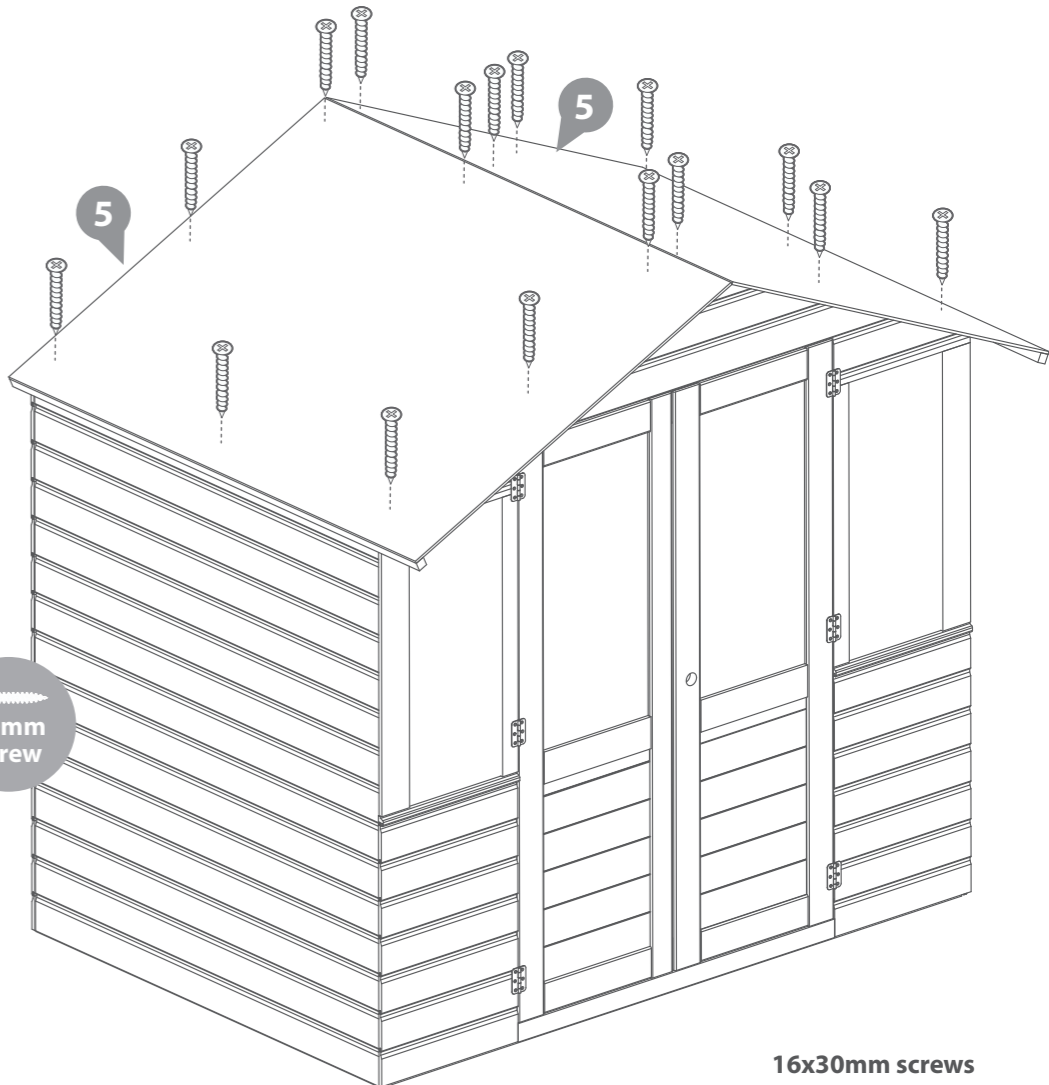

16x30mm screws

### Step 6

Fix a corner brace to both ends of the ridge bar using 30mm screws. Fix the Ridge bar between both gables ensuring the top edges of the ridge bar finish flush with the top of the gables. Fix in place using 30mm screws

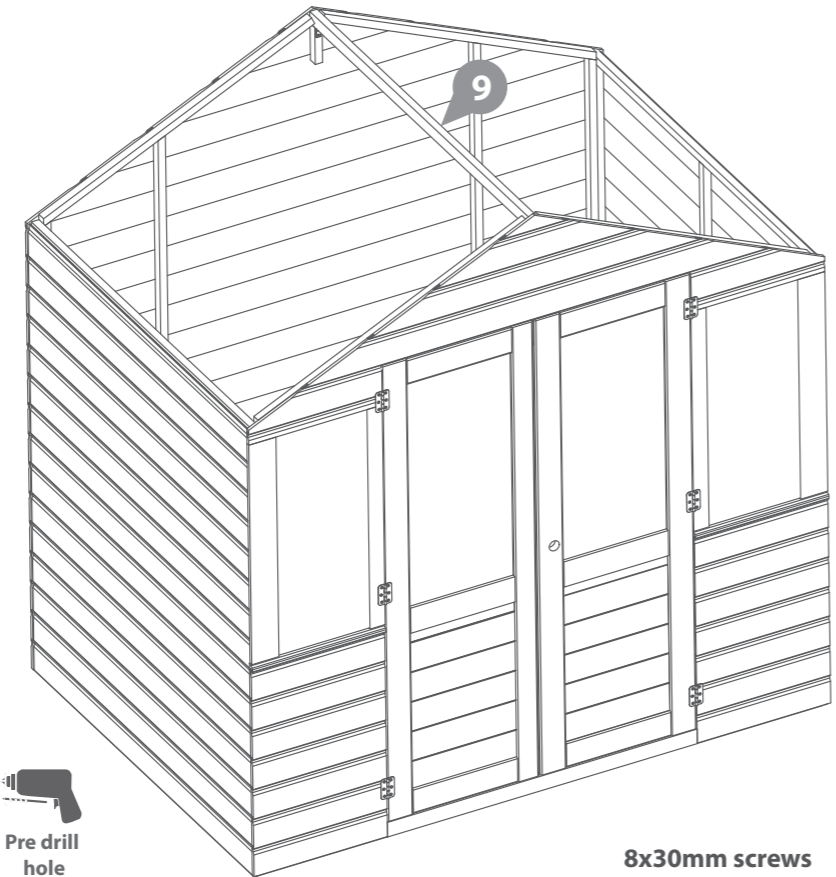
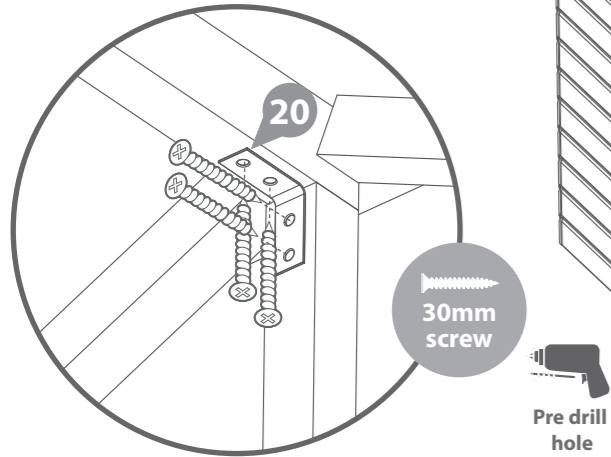

8x30mm screws

## Step 9

- b Fix the panels onto the floor using 50mm screws in alignment with the floor joists.

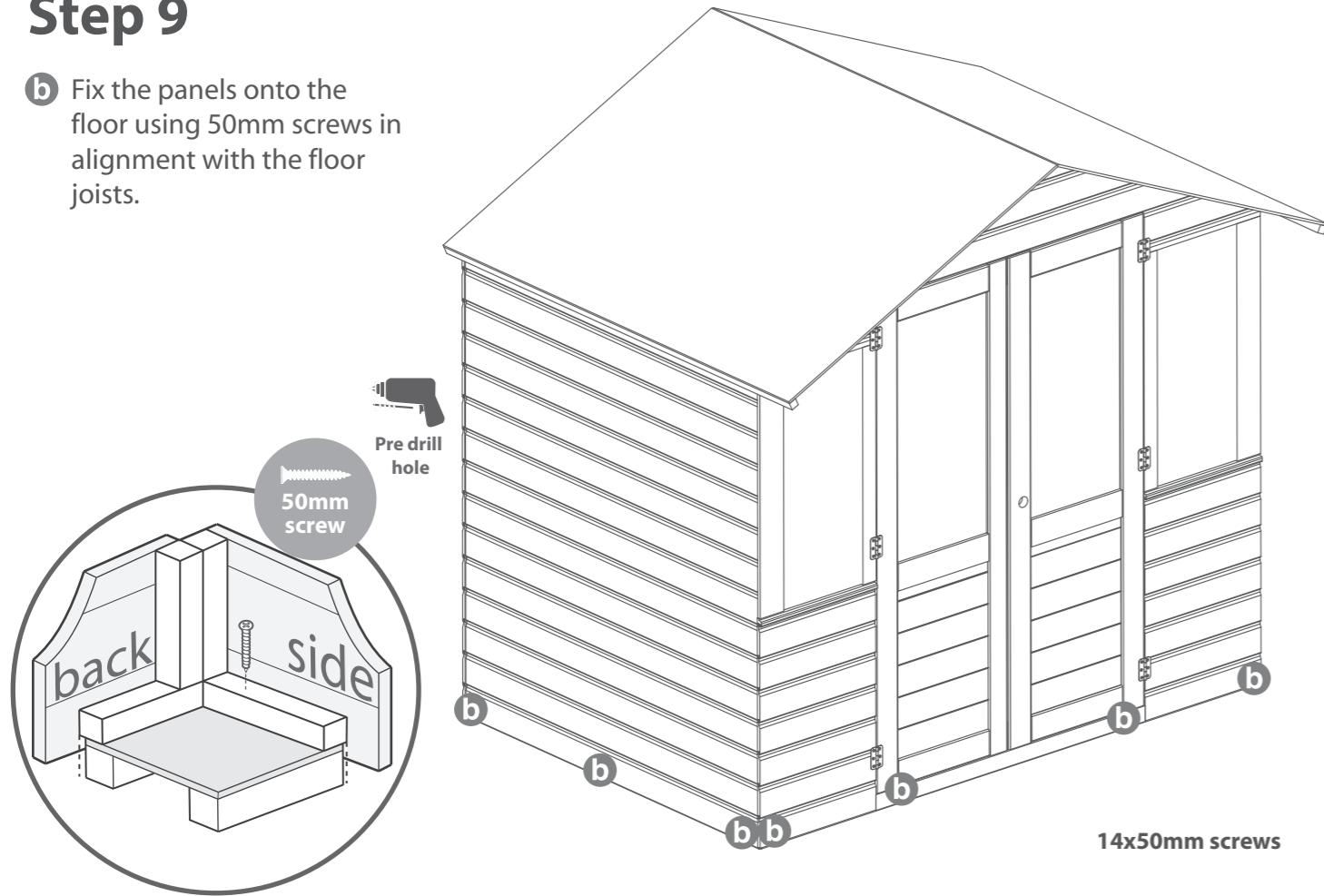

14x50mm screws

## Step 10

Fix the angled fascia block to the apex of the two roof sheets, ensure the block sits flush with the edge of the roof sheets. Secure with 2x40mm screws.

Place a fascia block in the middle of each roof sheet flush with the edge, fix in place with 2x40mm screw

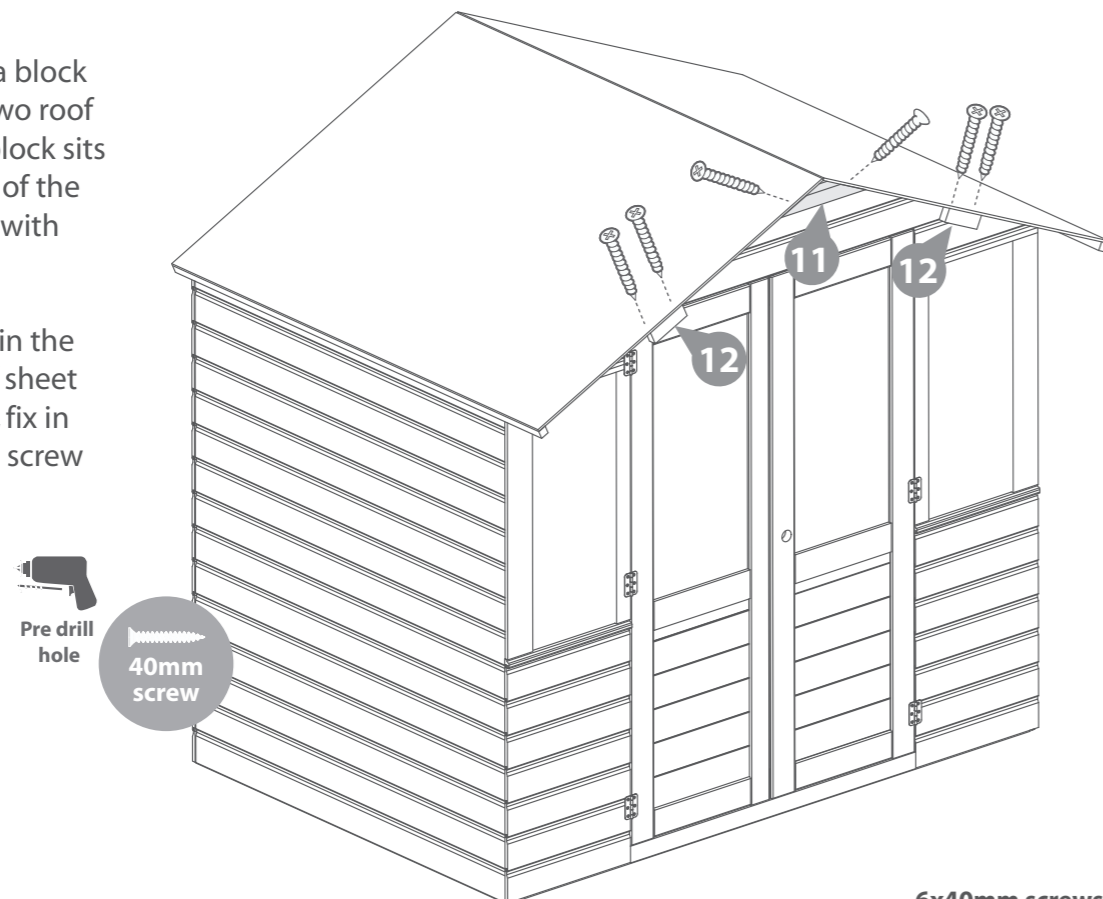

6x40mm screws

## Step 11

Cut felt into 3 equal sheets measuring 1820mm and lay onto roof as shown in diagram ensuring there is a 50mm overhang around the sides.

Fix using felt tacks at 100mm intervals

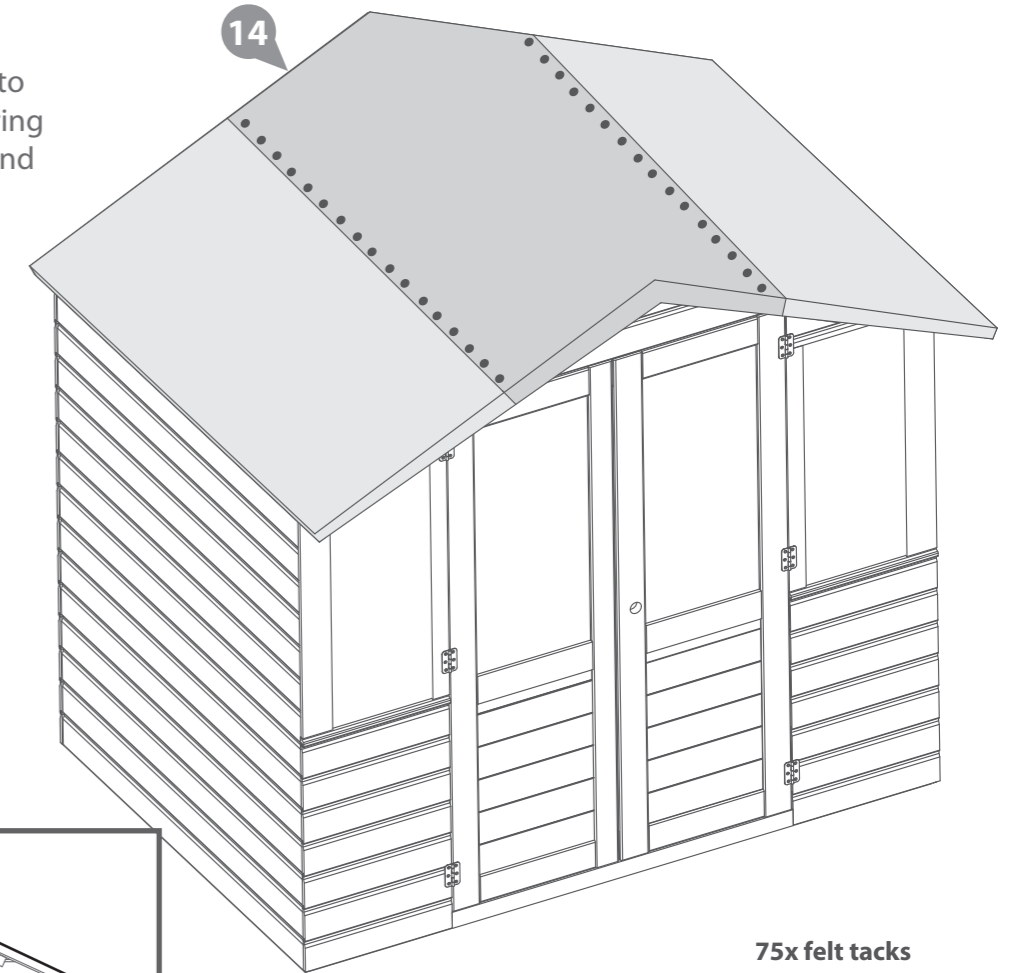
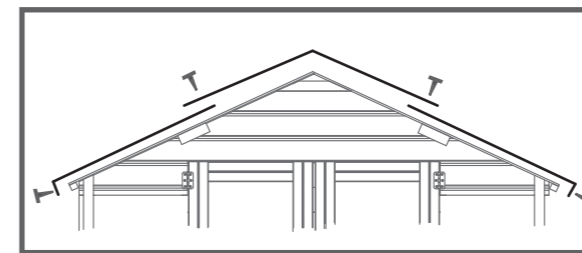

75x felt tacks

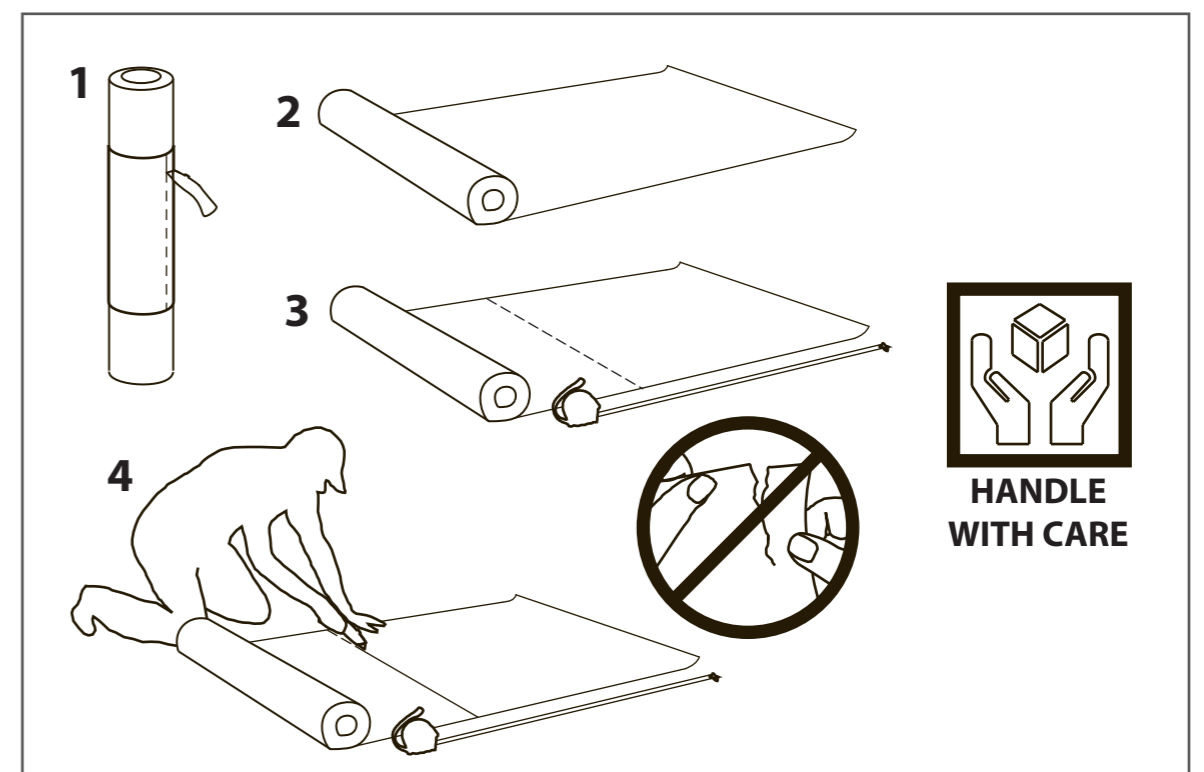

## Step 12

Fit the fascias to the front and back of the roof sheets ensuring to trap the felt between the fascia and the roof sheet. Use 40mm screws to fix the fascias in place.

Fix the finial where the fascias come together at the apex of the building at the front and back using 40mm screws.

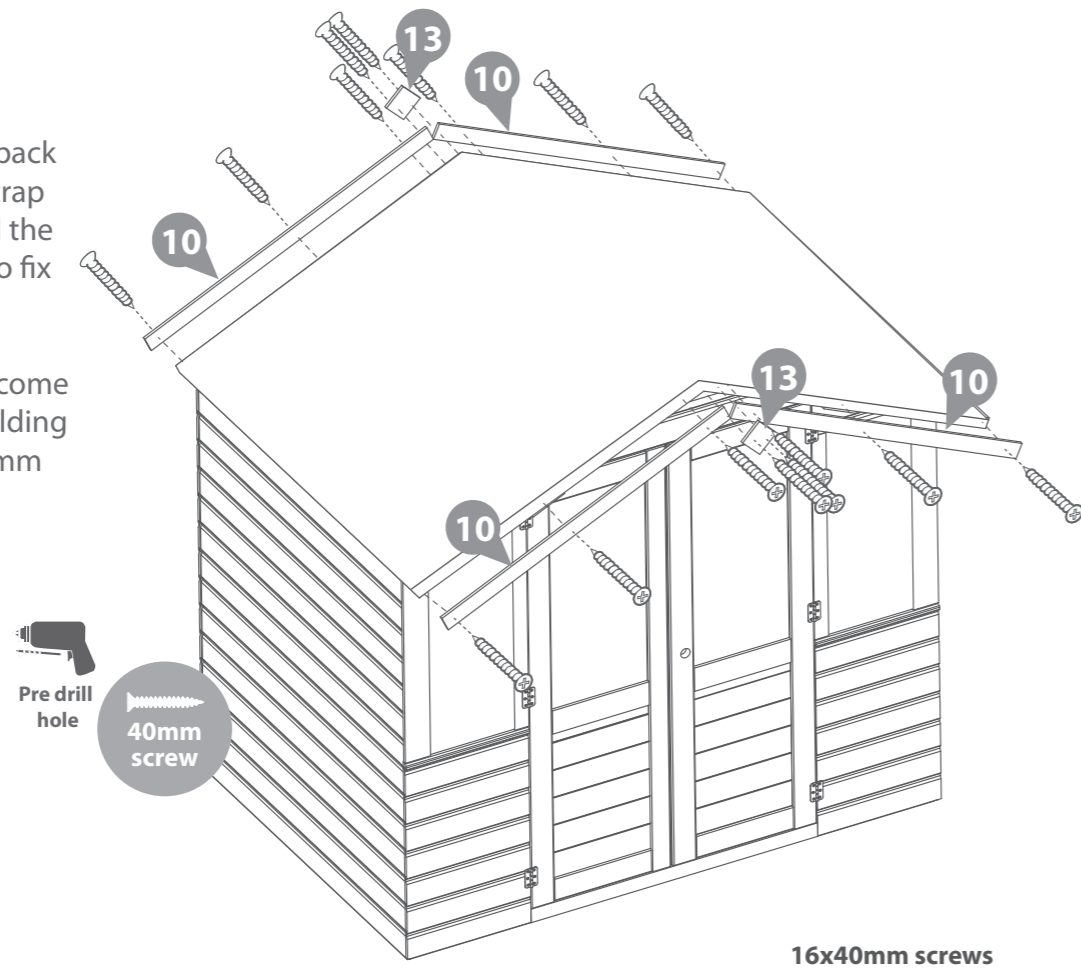

16x40mm screws

## Step 13

Pre drill holes then fix the Chrome Handle using 35mm bolt as shown in diagram.

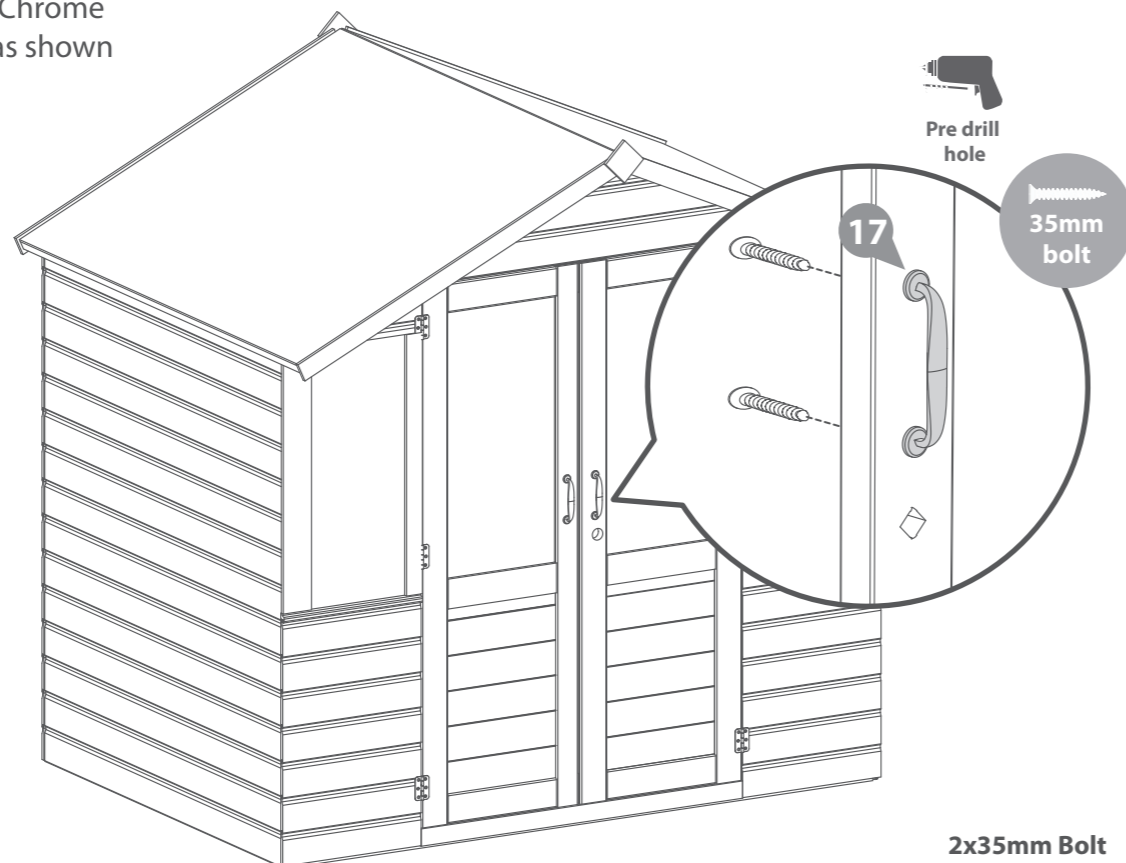

2x35mm Bolt

## Step 14

Fix the press lock to the door using 4x16mm black screws ensuring the key hole lines up with the hole in the door.

Fit the barrel bolts to top and bottom of the door as shown in the diagram. Use 4x10mm screws per barrel bolt.

Ensure doors open and close freely.

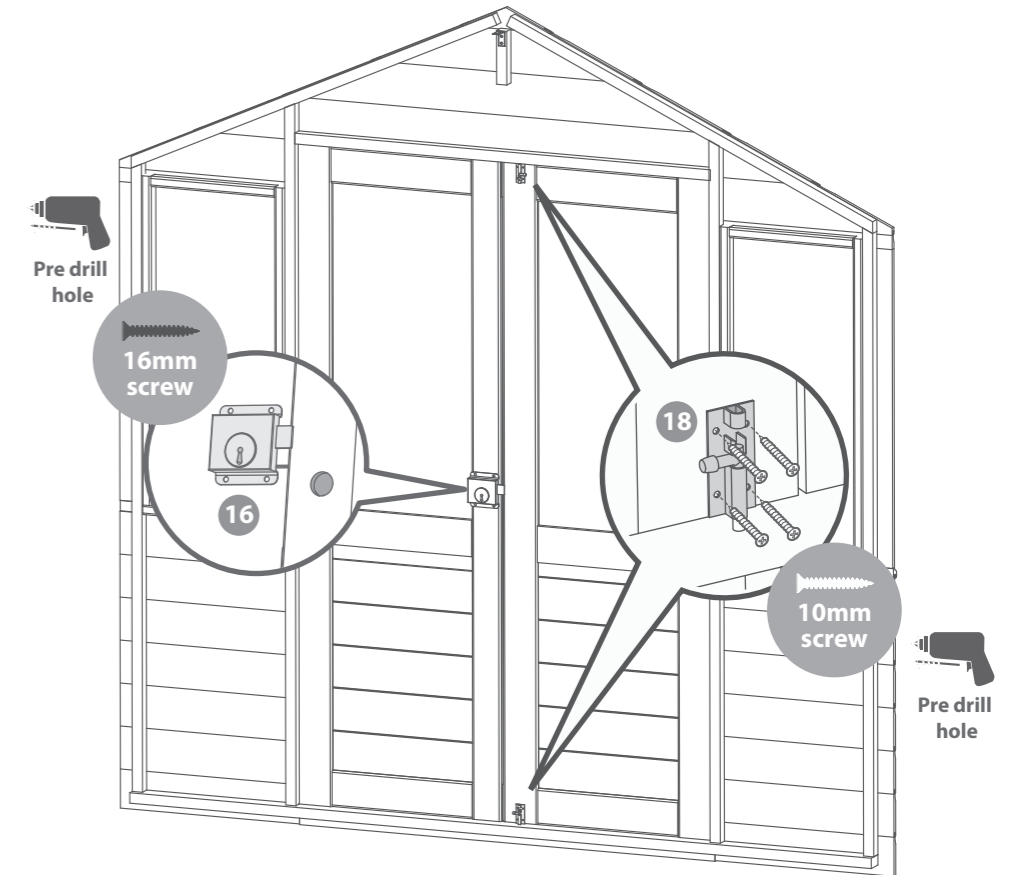

4x16mm Black Screws  
12x10mm Screws

## Step 15

Attach a turn button to the top and bottom of the slave door using 16mm black screws.

These turn buttons help to keep your doors straight during high levels and low levels of moisture content in the air.

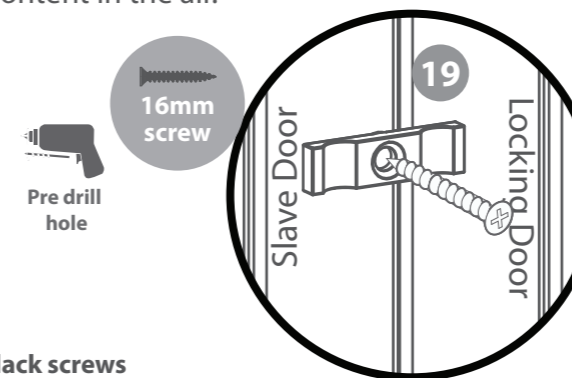

2x16mm Black screws

