

Thermo-electric actuator with manual opening and position indicator

6563 series



cert. n° 0003
ISO 9001

01142/06 GB



Function

The thermo-electric actuator, coupled with zone valves and distribution manifolds for radiant panel systems and radiators, performs the function of making the medium shut-off automatic with control by the room thermostat or another electrical switch.

The thermo-electric actuator 6563 series is equipped with a control knob for manual opening, valve opening/closing indicator and a device for returning to automatic operation from the manual position when the electricity supply is restored.

Patent application No. MI 2005 A 000742.

European directive conformity

CE mark in accordance with directives 89/336 EC and 73/23 EC.



Reference documentation

- Tech. broch. **01072** Zone valve 676 series
- Tech. broch. **01044** Distribution manifolds for radiant panel systems 668 series
- Tech. broch. **01065** Distribution manifolds for radiator systems 663 series
- Tech. broch. **01126** Manifolds in composite specifically designed for radiant panel systems 670 series

Product range

- Code 656302 Thermo-electric actuator with manual opening and position indicator _____ electric supply 230 V (ac)
- Code 656304 Thermo-electric actuator with manual opening and position indicator _____ electric supply 24 V (ac) or 24 V (dc)
- Code 656312 Thermo-electric actuator with manual opening, position indicator and auxiliary microswitch _____ electric supply 230 V (ac)
- Code 656314 Thermo-electric actuator with manual opening, position indicator and auxiliary microswitch _____ electric supply 24 V (ac) or 24 V (dc)

Technical specifications

Materials: - protective shell self-extinguishing polycarbonate
- colour (codes 656302/04) white RAL 9010
(codes 656312/14) grey RAL 9002

Normally closed
Electric supply: 230 V (ac) - 24 V (ac) - 24 V (dc)
Starting current: ≤ 1 A
Working current: 230 V (ac) = 13 mA
24 V (ac) - 24 V (dc) = 140 mA

Power consumption: 3 W
Auxiliary microswitch contacts rating (codes 656312/14): 0,8 A (230 V)
Protection class: IP 40
Double insulation construction: CE
Max. ambient temperature: 50°C
Operating time: opening and closing from 120 s to 180 s
Length of supply cable: 80 cm

Dimensions

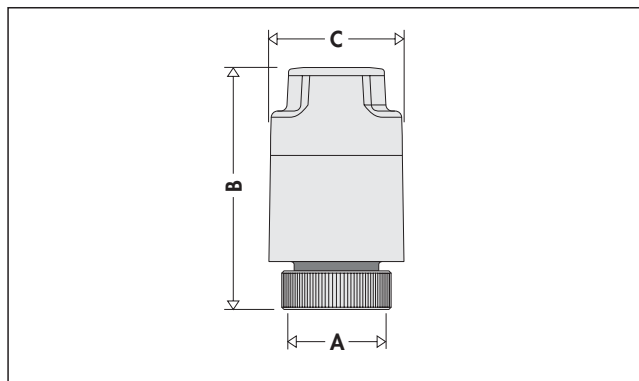

Code	A	B	C	Weight (kg)
6563..	M 30 x 1,5	76	42	0,18

Principle of operation

With no power, the device (actuator + valve), is “normally closed”. With power, the valve opens thanks to the action of a wax thermostatic expansion element governed directly by a PTC resistor.

Construction details

The thermo-electric actuator 6563 series is equipped with an automatic valve opening position indicator, a knob for opening the valve manually and a mechanism for returning to automatic mode if the electricity supply is restored.

The control knob for manual opening and the automatic return from the manual to the automatic position is particularly useful when testing or servicing the system if:

- hydraulic tests need to be carried out without having necessarily to connect and power up the controls.
- the knob is left on the manual position at the end of the tests. In this case the control automatically goes back onto automatic operation when the system is electrically put into operation.

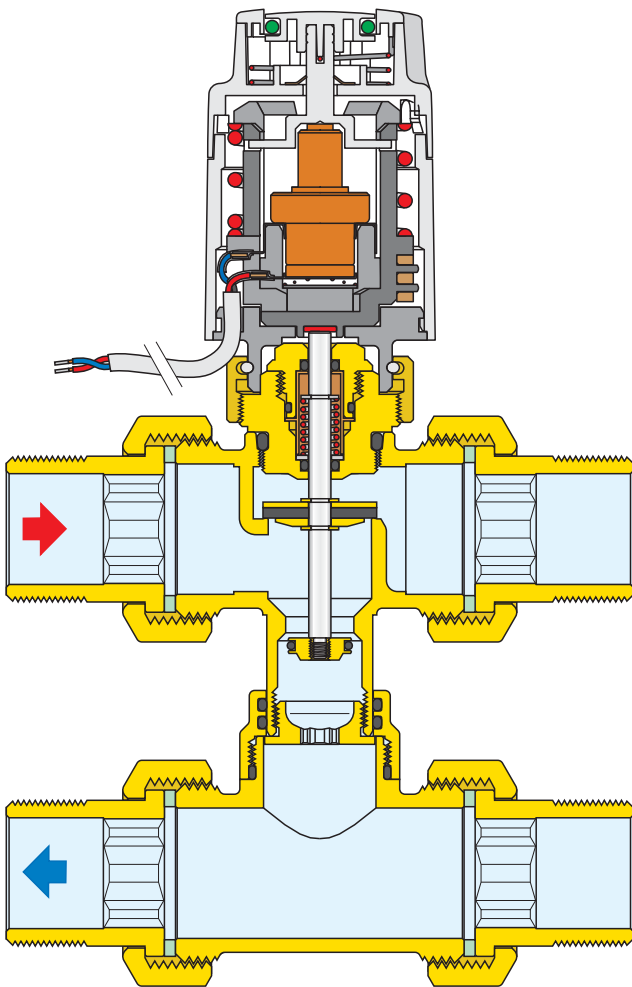

Valve in by-pass position

Using the thermo-electric actuator

1. Normal operation of the control in automatic mode.

In automatic mode, the thermo-electric actuator opens the valve when it is supplied with electricity. The opening is displayed by the central disc raising on the top of the knob and by the green circular indicator too.

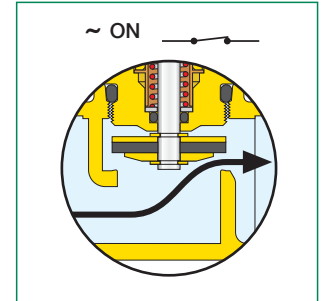
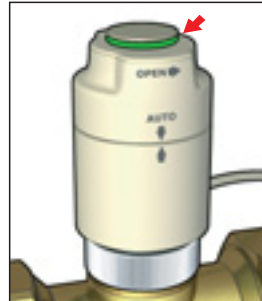

2. Using the knob to open the valve manually:

Turn the knob on the top of the control anticlockwise until its limit stop trips and the arrow symbols and  overlap. To close the valve manually and restore automatic operation of the device, turn the knob clockwise onto “AUTO”.

Note: On the series equipped with an auxiliary microswitch, in the manual opening position the micro contact is closed.

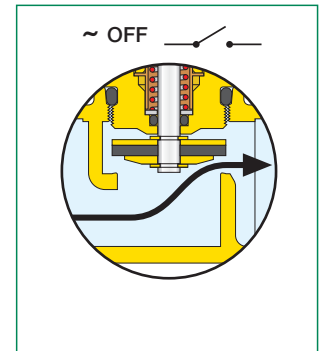

3. Automatic return from the manual position to the automatic one.

When the control in the manual position is powered, an internal mechanism enables automatic release from this position and a return to normal operation.

A few seconds after powering up, the knob will automatically return to the “AUTO” position and the opening indicator will stay on the open position.

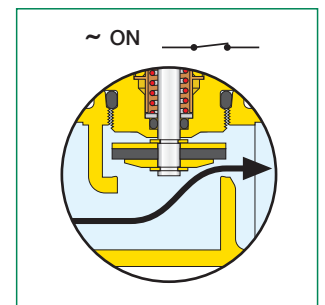

Electrical connections

- Electrical connections for codes 656302, 656304.

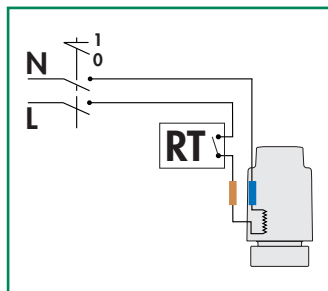
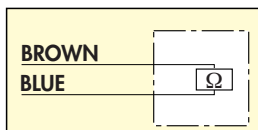

- Electrical connections for codes 656312 and 656314
Wiring diagram with pump disconnection.

The auxiliary microswitch can be used to disconnect the pump when the services do not need any heat and the valves are shut.

If the pump input exceeds the capacity of the contacts equal to 0,8 A, an intermediate contactor should be used.

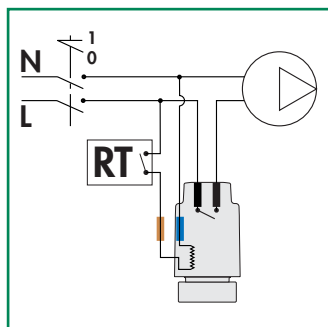
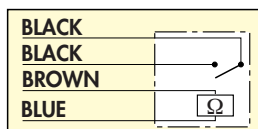

The auxiliary microswitch turns on for an average opening value of the thermo-electric actuator of 80%.

Coupling table

				656302 656304 656312 656314	
676 	677 	678 			
663 	666-668 	670 			

Hydraulic characteristics

Table of hydraulic characteristics of control 6563 + valve body

656302, 656304, 656312, 656314 +	Series	DN	kv _{0,01} (l/h)	Δp _{max} * (m w.g.)
Zone valve (straight/by-pass)	676		370	12
	677	1/2"-1"	370/100	12
	678		370/100	12
Manifold for radiant panel systems and radiators	663	1 1/4"	287	25
	666	1 1/4"	287	25
	668	1 1/4"	287	25
	670	1"	240	25

* Maximum pressure differential assured by the servo control for regular operation

Installation

- The thermo-electric actuator should be tightened by hand without the use of tools.
- The thermo-electric actuator should not be dismantled for possible repair. Such interference could lead to permanent damage.
- The actuator should always be fitted in a horizontal or vertical position, **never upside-down**. In chilled water circuits, positions which allow condensation to get into the actuator are not advisable.
- For the correct functioning of the actuator, **the electrical circuit should be sized on the basis of the starting current.**
- **If it is necessary to control multiple zones with actuators in parallel using the same thermostat, the possibility of including an intermediate relay to prevent electrical overload should be considered.**
- In assemblies with zone valves or manifold in manifold boxes, a space of at least 20 mm between the thermo-electric actuator and the frame should be left for possible servicing or replacement.

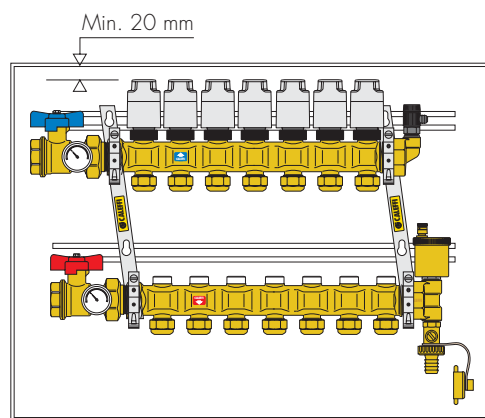

Recommendations for use

When thermo-electric actuators are to be installed on devices with automatically shut off the heating elements, it is always advisable to use a differential by-pass to control over-pressure of the system during the partial or total closure of the circuits:

- For pre-assembled manifolds 668 series a differential by-pass with a fixed calibration setting of 2500 mm w.g. is available, code 668000; whereas for pre-assembled manifolds 663 series a differential by-pass with a fixed calibration setting of 2000 mm w.g. is available, code 663000.

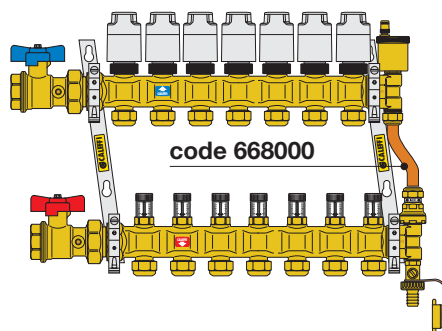

- For centralised installations or installations with rising pipes, a differential by-pass valve is available with an adjustable setting of 1 to 6 m w.g., 519 series.

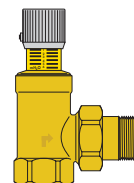

Applications

The thermo-electric actuators with manual opening and position indicator can be installed in the various types of systems listed below:

- In zone systems, requiring reduced overall dimensions and a limited coefficient of the flow rate to the automatic regulating valve.
- In systems with fan coils, if you want to fit them with valves to shut off the medium automatically.

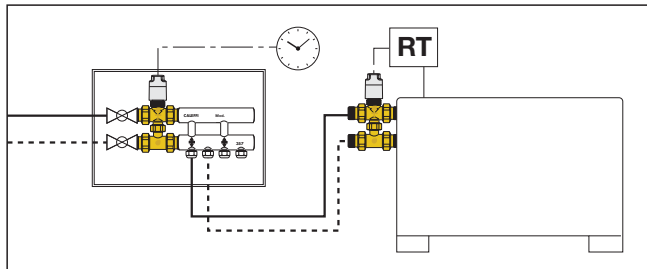

- In radiant panel systems and radiators, if you want to:
 - adjust the temperature in the single ambients heated by the circuits branching out from the manifold.
 - shut off each circuit directly from the manifold, with less work and expense to make the electrical connections.

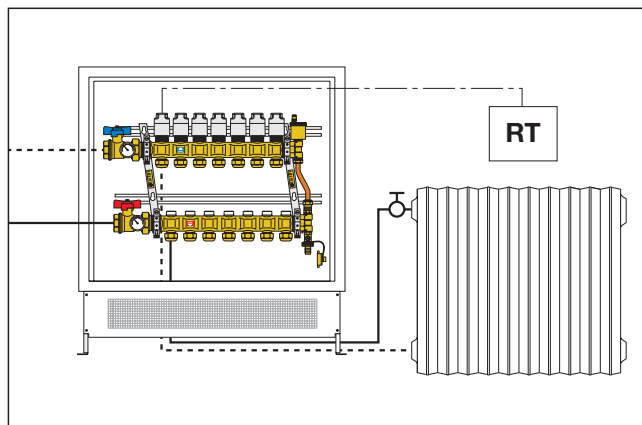
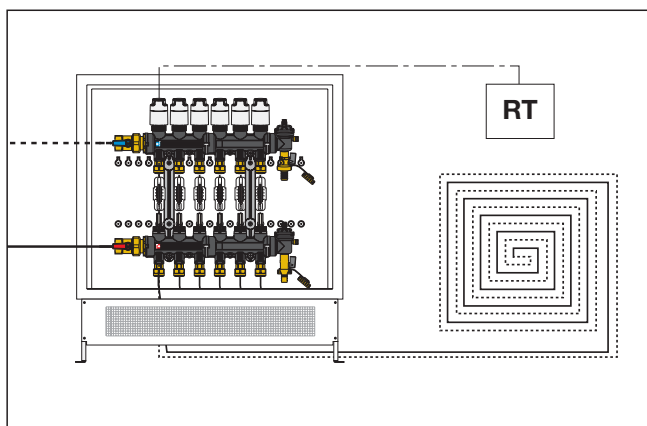

- In plumbing systems to adjust the temperature in water storage heaters.

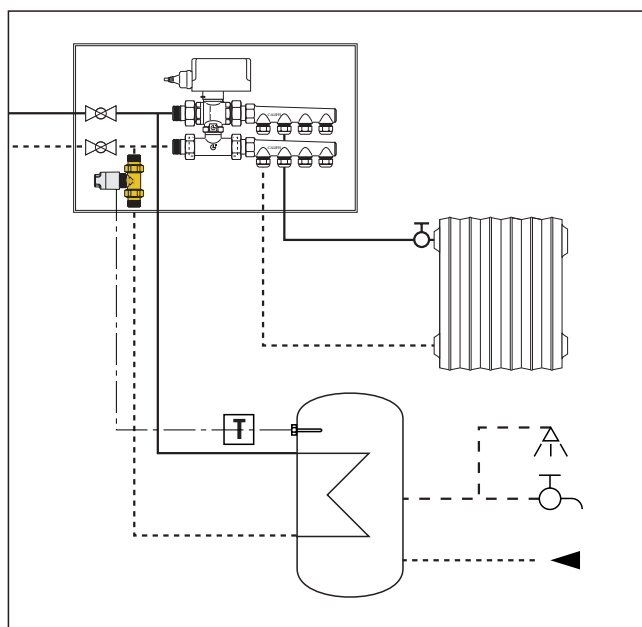

SPECIFICATION SUMMARIES

Codes 656302/04

Thermo-electric actuator with manual opening and position indicator. Normally closed. Self-extinguishing polycarbonate protective shell. RAL 9010 white colour. Supply voltage: 230 V (ac); 24 V (ac); 24 V (dc). Starting current: ≤ 1 A. Working current: 13 mA (230 V (ac)), 140 mA (24 V (ac) - 24 V (dc)). Power consumption: 3 W. Protection class: IP 40. Made with double insulation. Maximum ambient temperature: 50°C. Operating time opening/closing from 120 to 180 s. Length of supply cable: 80 cm.

Codes 656312/14

Thermo-electric actuator with manual opening and position indicator. Normally closed with auxiliary microswitch. Self-extinguishing polycarbonate protective shell. RAL 9002 grey colour. Supply voltage: 230 V (ac); 24 V (ac); 24 V (dc). Starting current: ≤ 1 A. Working current: 13 mA (230 V (ac)), 140 mA (24 V (ac) - 24 V (dc)). Power consumption 3 W. Auxiliary microswitch contacts rating 0,8 A (230 V). Protection class: IP 40. Made with double insulation. Maximum ambient temperature: 50°C. Operating time opening/closing from 120 to 180 s. Length of supply cable: 80 cm.

We reserve the right to change our products and their relevant technical data, contained in this publication, at any time and without prior notice.

