

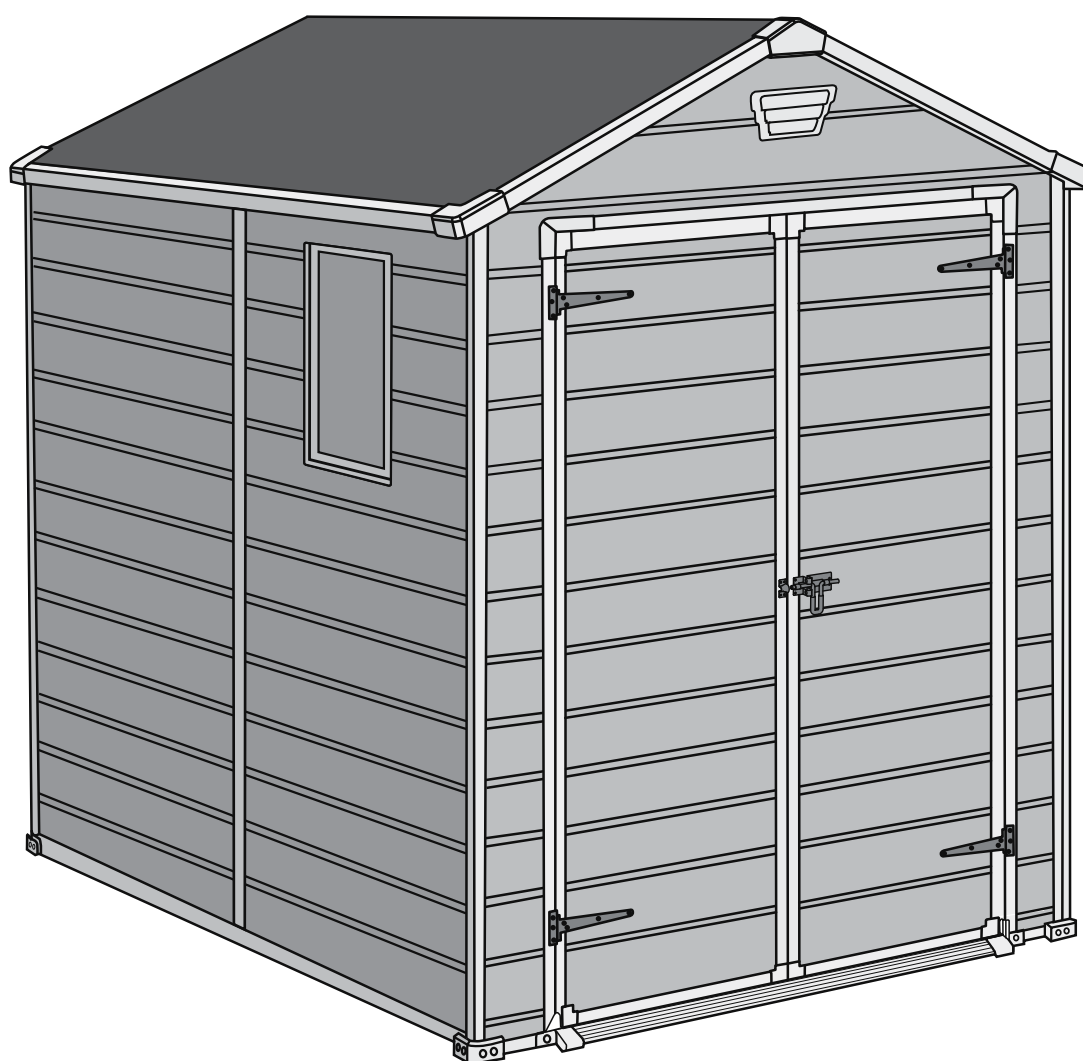

# MANOR 6x8DD

USER MANUAL | MODE D'EMPLOI | MANUAL DEL USUARIO | GEBRAUCHSANLEITUNG |  
GEBRUIKSHANDLEIDING | MANUALE PER L'UTENTE | MANUAL DO UTILIZADOR



A-1276-9 577718

SKU: 17196659 | 17197129

	<p>US, Canada : Tel: 1-(888)-374-4262, Fax: 317-575-4502 UK: Tel: 0121-5060008, Fax: 0121-4220808 Spain: Tlf: +34.949 27 74 21, Fax: +34.949 34 89 76 Other Eu ropean Countries : Tel: 31-1612-28301, Fax: 31-1612-28322</p>		
--	--	--	--

**WARRANTY ACTIVATION** Thank you for your purchase of the Keter shed. In order to activate your warranty, please log onto our website and fill in the form under warranty activation.

**SITE PREPARATION | PRÉPARATION DU SITE | PREPARACIÓN DEL LUGAR | VORBEREITUNG DES AUFSTELLUNGORTES  
| VOORBEREIDING VAN HET TERREIN | PREPARAZIONE DEL LUOGO DI MONTAGGIO | PREPARAÇÃO DO LOCAL**

**Level the ground surface | Égalisez la surface du sol | Nivele la superficie del suelo | Ebnen Sie die Bodenoberfläche |  
Maak de bodem vlak | Livella la superficie del terreno | Nivele a superfície do solo**

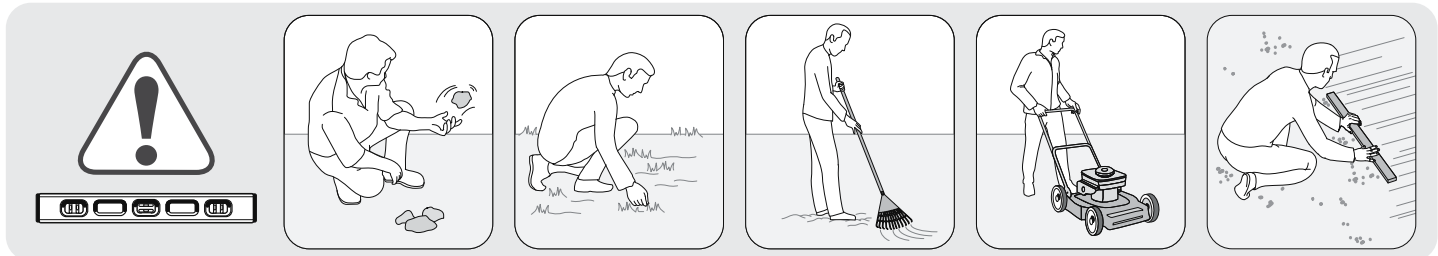

**Recommendation:** Construct a wooden or concrete base as a foundation | **Recommandation:** fabriquez une base en bois ou en béton en guise de fondation | **Recomendación:** construya una base de madera o de cemento a modo de cimiento | **Empfehlung:** Bauen Sie als Fundament eine Grundfläche aus Holz oder Beton | **Aanbeveling:** maak een houten of betonnen ondergrond als fundering | **Raccomandazione:** costruisci una base di legno o di cemento come fondamenta | **Recomendação:** Construa uma base de madeira ou de cimento como fundação

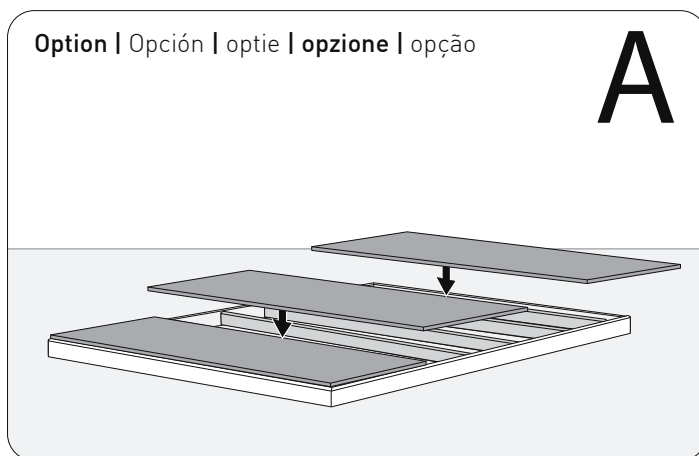

**External floor measurements are: | Les mesures externes de la étage sont: | Las medidas del suelo externo son: | Die Außen-Bodenmaße betragen: | De afmetingen van de externe vloer zijn: | Le misure del pavimento esterno sono: | As medidas externas do chão são:**

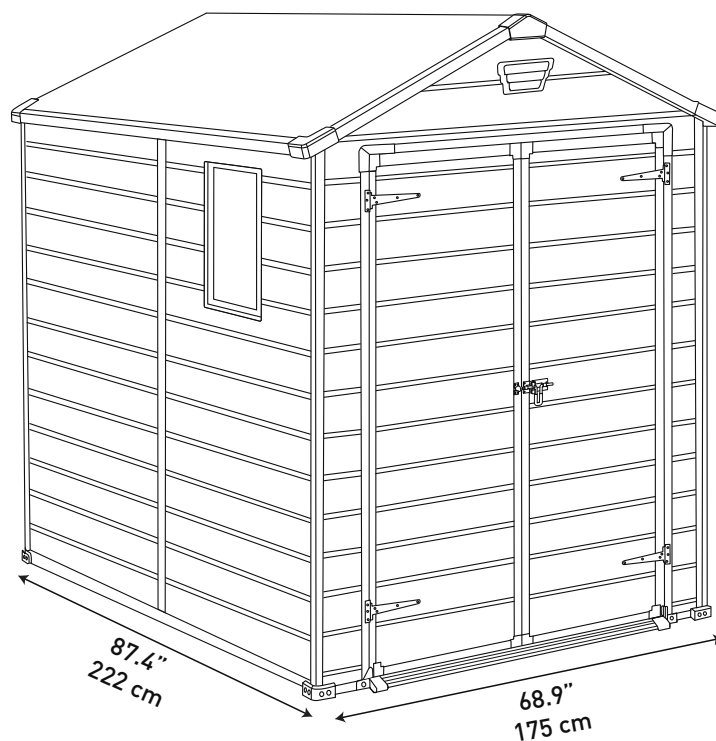

**BEFORE STARTING ASSEMBLY | AVANT DE COMMENCER LE MONTAGE | ANTES DE EMPEZAR EL ARMADO | VOR MONTAGEBEGINN | VOORDAT U BEGINT TE MONTEREN | PRIMA DI INIZIARE IL MONTAGGIO | ANTES DE INICIAR A MONTAGEM**

**Read the care and safety guidelines at the end of this manual | Check to ensure that there are no missing or damaged parts BEFORE starting or arranging assembly | Review all assembly instructions | Assemble all the parts according to the directions in this manual. Do not skip any steps.**

Lisez les instructions de précaution et de sécurité à la fin de ce manuel | Assurez-vous qu'il n'y a pas de pièces manquantes ou endommagées AVANT de commencer ou d'organiser l'assemblage | Lisez toutes les instructions de montage | Assemblez toutes les pièces selon les instructions de ce manuel. Ne sautez aucune étape.

**Lea las intrucciones de precauciones y seguridad que están al final de este manual | Asegúrese de que no faltan piezas ni están dañadas ANTES de comenzar o disponer el montaje | Revise todas las instrucciones de montaje | Monte todas las piezas según las instrucciones de este manual. No se saltee ningún paso.**

Lesen Sie die Sicherheitsrichtlinien am Ende des Benutzerhandbuchs durch | Prüfen Sie bitte VOR dem Zusammenbau, dass keine Teile beschädigt sind oder fehlen | Gehen Sie noch einmal die komplette Aufbauanleitung durch | Bauen Sie alle Teile entsprechend der Anleitung in diesem Handbuch zusammen. Lassen Sie dabei keinen Arbeitsschritt aus.

**Lees de richtlijnen voor zorg en veiligheid achterin deze handleiding | Controleer dat er geen onderdelen mankeren, of beschadigd zijn, VOORDAT u met de montage begint | Bekijk alle montagehandleidingen | Monteer alle onderdelen volgens de aanwijzingen van deze handleiding. Sla geen stappen over.**

Leggi le linee guida di assistenza e sicurezza alla fine di questo manuale | Verificare per assicurarsi che non ci siano parti mancanti o danneggiate PRIMA di iniziare o di disporre il montaggio | Consulta tutte le istruzioni di montaggio | Monta tutti i componenti secondo le istruzioni contenute in questo manuale. Non saltare nessuna fase.

**Leia as diretrizes de cuidados e segurança que constam da parte final deste manual | Verifique para se assegurar de que não há peças em falta ou danificadas ANTES de começar a preparar a montagem | Reveja todas as instruções de montagem | Monte todas as peças de acordo com as instruções do manual. Não salte quaisquer passos.**

**REQUIRED TOOLS | OUTILS EXIGÉS | HERRAMIENTAS NECESARIAS | BENÖTIGTE WERKZEUGE | BENODIGD GEREEDSCHAP | ATTREZZATURA OCCORRENTE | FERRAMENTAS NECESSÁRIAS**

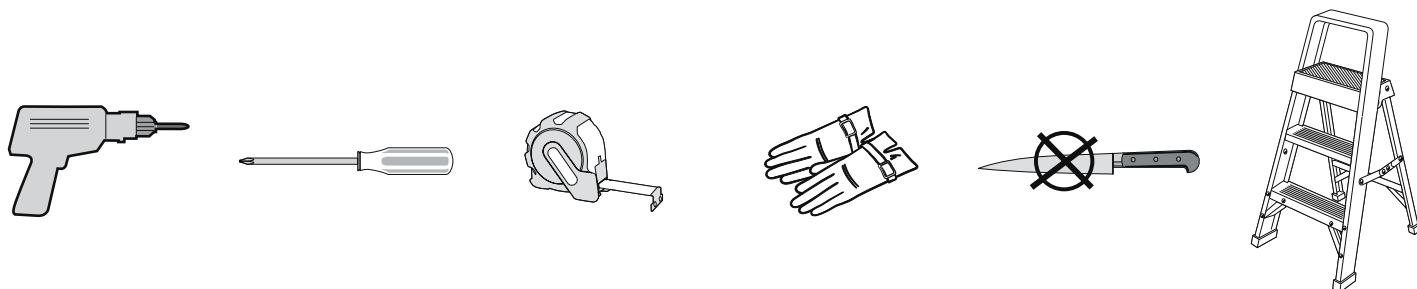

**SPATULA | SPATULE | ESPÁTULA | SPACHTEL | SPATEL | SPATOLA | ESPÁTULA**

- Use spatula (part "SPA") for easier insertion of panel into profile.
- Utilisez la spatule (partie "SPA") pour une meilleure insertion du panneau dans le profil.
- Utilice una espátula (pieza "SPA") para una mejor inserción del panel en el perfil.
- Benutzen Sie den Spachtel (Bezeichnung „SPA“), um die Platten leichter in die Nut einführen zu können.
- Gebruik spatel (onderdeel SPA) voor het gemakkelijk invoeren van het paneel in het profiel.
- Utilizzare la spatola (parte SPA) per inserire il pannello più facilmente nel profilo.
- Utilize uma espátula (peça "SPA") para facilitar a inserção do painel no perfil.

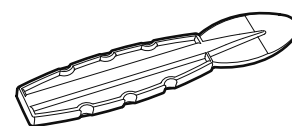

**spa x1**



**ASSEMBLY REQUIRES TWO PEOPLE | LE MONTAGE DOIT ÊTRE EFFECTUÉ PAR DEUX PERSONNES | SE NECESITAN DOS PERSONAS PARA ARMARLO | ZWEI PERSONEN ZUR MONTAGE NOTWENDIG | MONTAGE VEREIST TWEETWO PERSONEN | MONTAGGIO RICHIEDE DUE PERSONE | A MONTAGEM EXIGE DUAS PESSOAS**

## SHED PARTS | PIÈCES DE L'ABRI | PARTES DEL COBERTIZO | TEILE DES SCHUPPENS | ONDERDELEN VAN HET SCHUURTJE | COMPONENTI DEL DEPOSITO ATTREZZI | PEÇAS DO ABRIGO

Remove all parts from the package(s) and spread them out on a clean work surface | Code letters are imprinted on each part for easy identification | Retirez toutes les pièces du/des paquet(s) et étalez-les sur une surface de travail propre | Des lettres sont imprimées sur chaque pièce pour une identification facile | Saque todas las piezas del paquete o paquetes y póngalas sobre una superficie de trabajo limpia | El código de letras está marcado en cada pieza para que sea más fácil identificarla | Nehmen Sie alle Teile aus der Verpackung und breiten Sie sie auf einer sauberen Arbeitsfläche aus | Auf jedem Teil sind Kennbuchstaben aufgedruckt, die die Zuordnung der einzelnen Teile erleichtern | Haal alle onderdelen uit het pakket (of uit de pakketten) en leg ze op een schoon werkoppervlak | Op ieder onderdeel zijn codes aangebracht voor een gemakkelijke identificatie | Rimuovi tutti i componenti dal pacchetto (i) e spargili su una superficie di lavoro pulita | Le lettere del codice sono state stampate su ciascun componente per una facile identificazione | Retire todas as peças da embalagem e espalhe-as numa superfície de trabalho limpa | Existem letras de código impressas em cada peça para fácil identificação

## FLOOR PARTS | ÉLÉMENTS DU PLANCHER | PARTES DEL SUELO | BODENTEILE | VLOERONDERDELEN | PARTI DEL PAVIMENTO | PEÇAS DO CHÃO

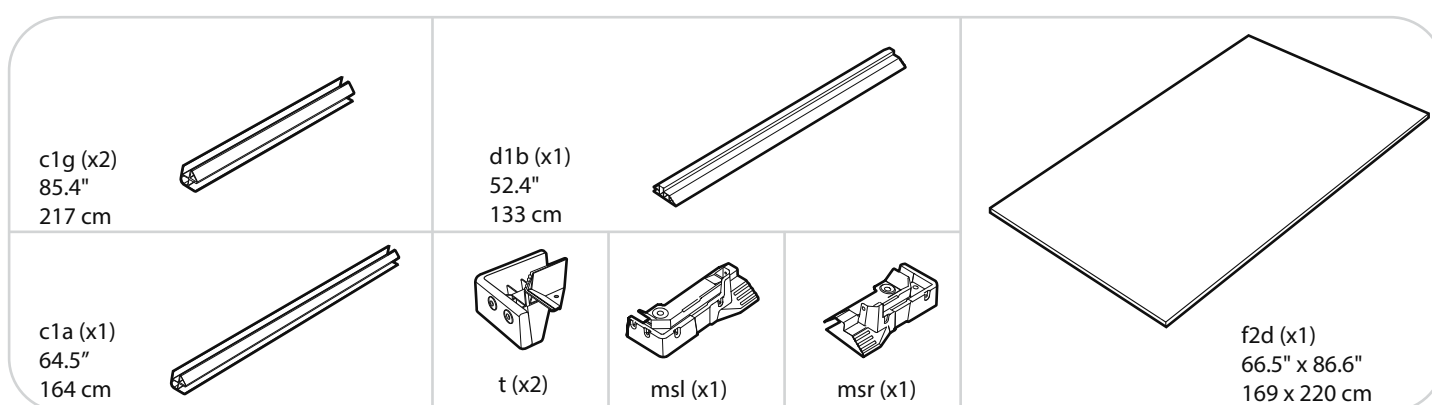

## WALL PARTS | PIÈCES DU CONTOUR | PARTES DE LAS PAREDES | WANDELEMENTE | MUURONDERDELEN | PARTI DELLA PARETE | PAINÉIS LATERAIS

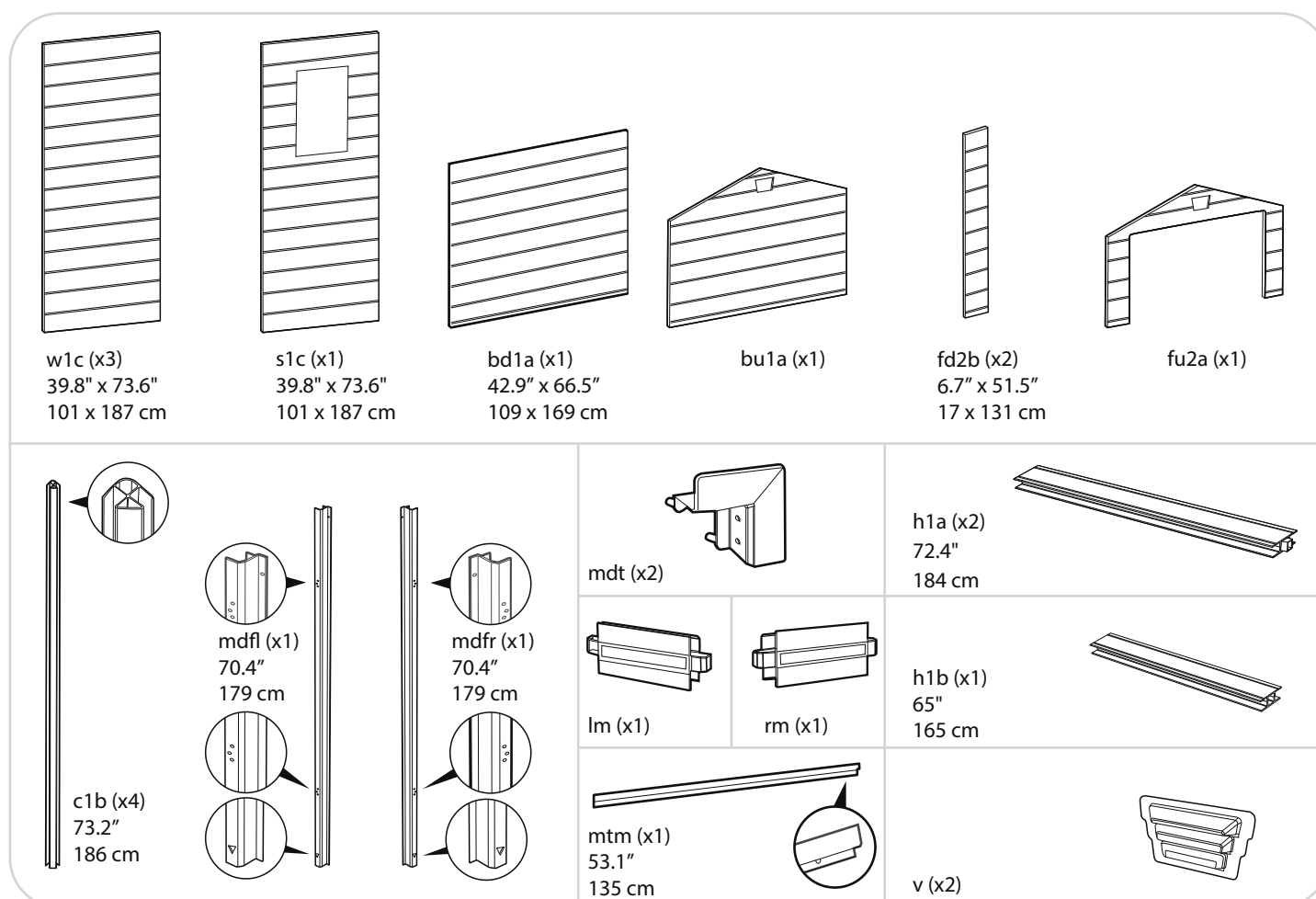

**DOOR PARTS | PIÈCES DE LA PORTE | TÜRELEMENTE | PARTES DE LA PUERTA | DEURONDERDELEN | PARTI DELLA PORTA | PEÇAS DAS PORTAS**

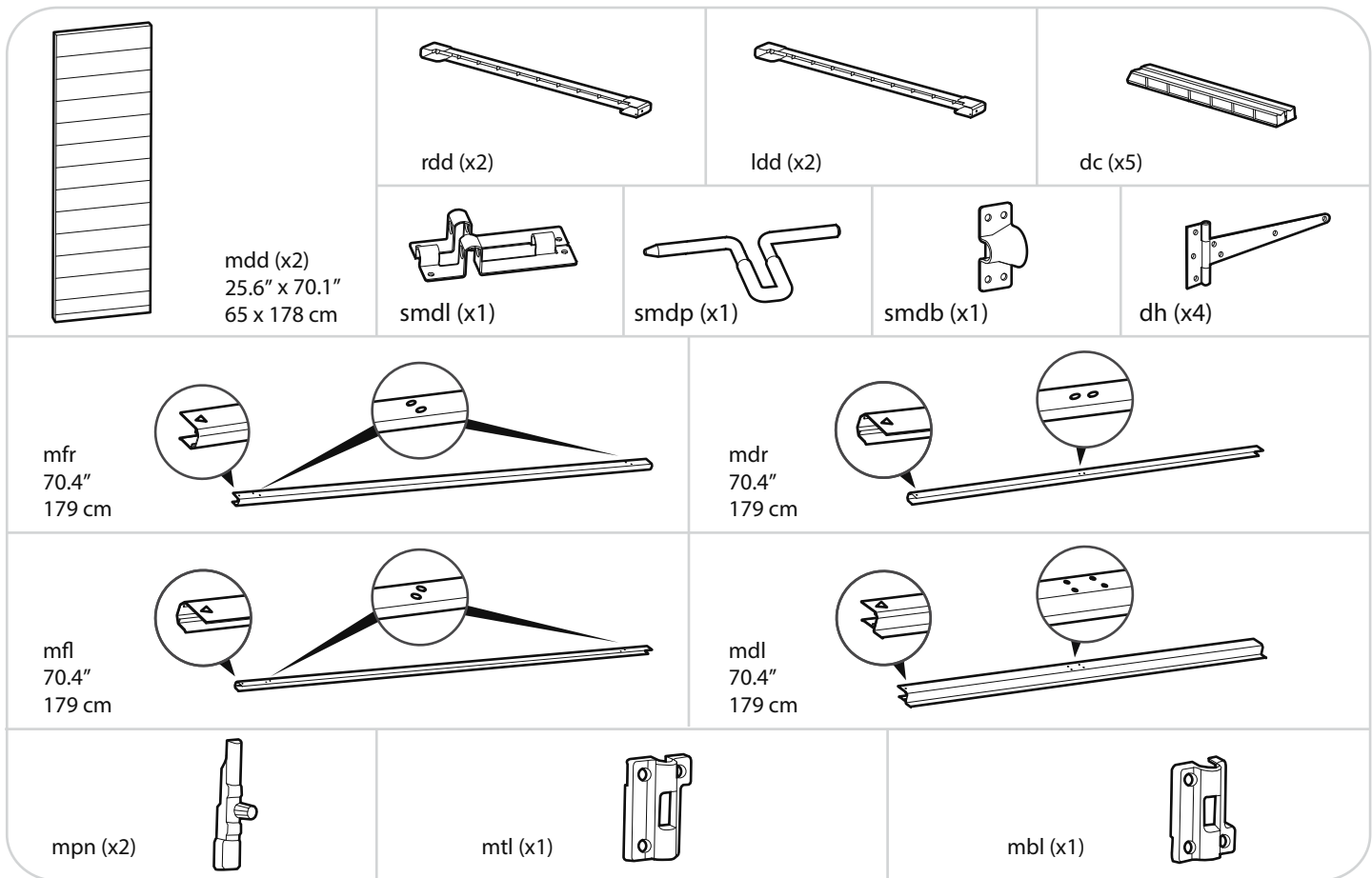

**ROOF PARTS | PIÈCES DU TOIT | PARTES DEL TECHO | DACHELEMENTE | DAKONDERDELEN | PARTI DEL TETTO | PEÇAS DO TELHADO**

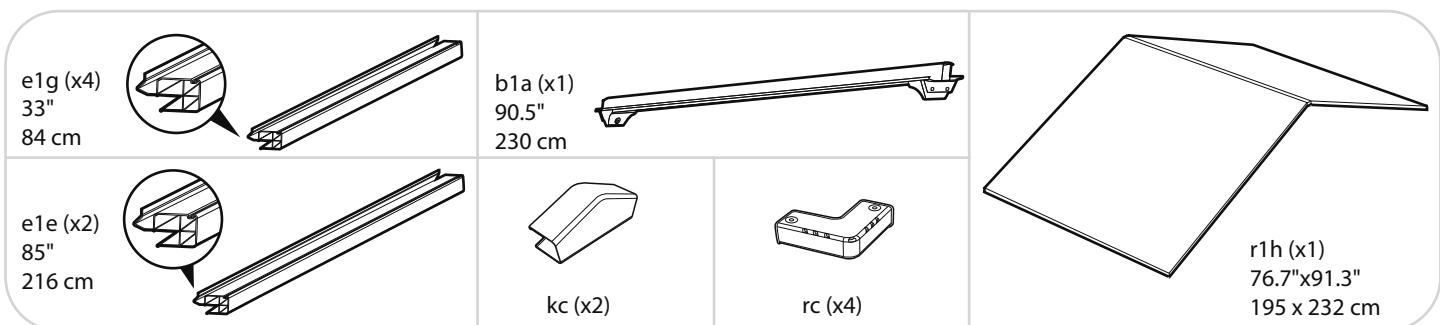

**WINDOW PARTS | PIÈCES DE LA FENÊTRE | PARTES DE LA VENTANA | FENSTERELEMENTE | VENSTERONDERDELEN | PARTI DELLA FINESTRA | PEÇAS DA JANELA**



**CONSTRUCTION PARTS | PIÈCES DE CONSTRUCTION | PIEZAS PARA EL MONTAJE | BAUTEILE | CONSTRUCTIEONDERDELEN | PARTI PER LA COSTRUZIONE | PEÇAS DE CONSTRUÇÃO**

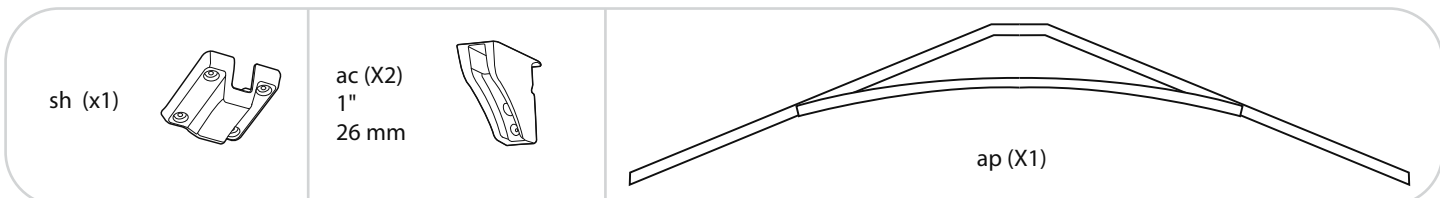

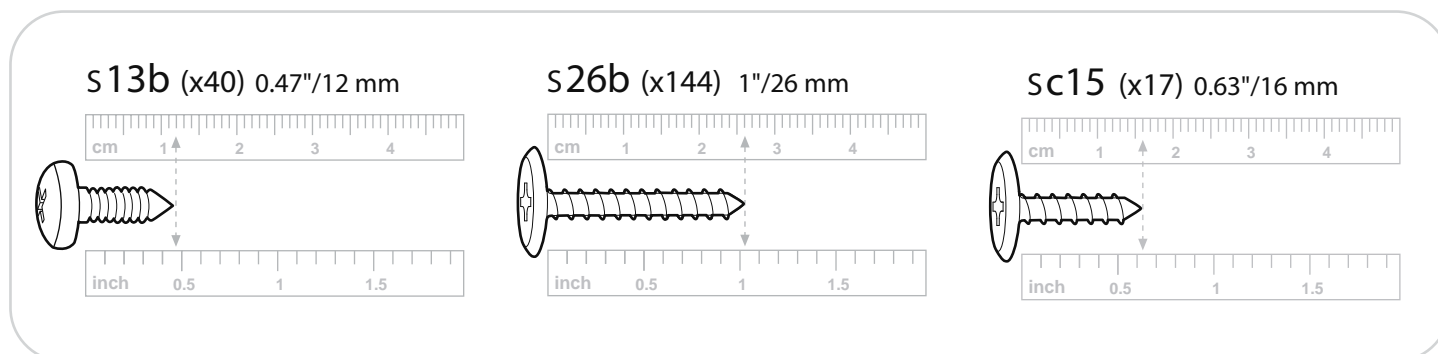
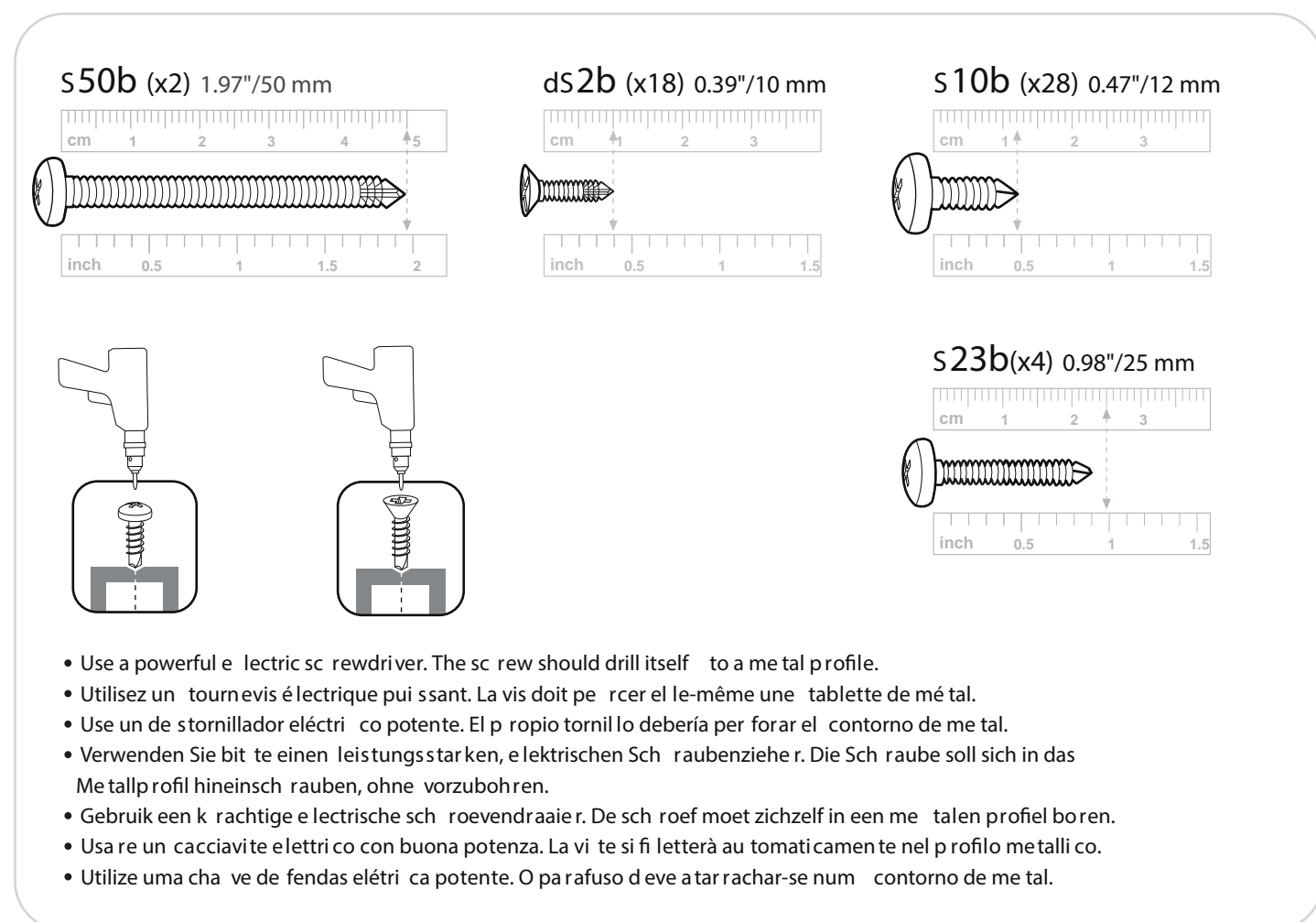
**SCREWS | VIS | TORNILLOS | SCHRAUBEN | SCHROEVEN | VITI | PARAFUSOS**

**SELF-DRILLING SCREW | VIS AUTO-FOREUSE | TORNILLO DE AUTO-ATORNILLADO | SELBSTBOHRENDE SCHRAUBE | ZELF TAPPENDE SCHROEF | VITE AUTOFILETTANTE | PARAFUSO AUTORROSCANTE**

**Packaging may contain some additional small parts for use as spare parts | L'emballage peut contenir de petites pièces supplémentaires à utiliser comme pièces de rechange | El envoltorio puede contener algunas piezas pequeñas adicionales que se pueden utilizar como repuestos | In der Verpackung können kleine Zusatzteile enthalten sein, die als Ersatzteile genutzt werden können | De verpakking kan een aantal kleine extra onderdelen bevatten, die als reserveonderdeel gebruikt kunnen worden | La confezione potrebbe contenere piccole parti supplementari da utilizzare come parti di ricambio | A embalagem pode conter algumas pequenas peças adicionais para utilização como peças de reposição**

**NOTE:** Due to variations in production, the actual assembled size may vary slightly from the specified dimensions.

**REMARQUE:** En raison de variantes dans la production, la taille de montage réelle peut différer quelque peu des dimensions indiquées.

**NOTA:** debido a las variaciones en la producción, el tamaño real al montarlo puede variar ligeramente con respecto a las dimensiones especificadas.

**BITTE BEACHTEN:** Aufgrund von Abweichungen in der Herstellung kann die tatsächliche Größe leicht von den angegebenen Maßen abweichen.

**LET OP:** vanwege afwijkingen in de productie kan de werkelijke afmeting na montage een klein beetje afwijken van de opgegeven afmetingen.

**NOTA:** a causa di variazioni nella produzione, la dimensione effettiva del prodotto assemblato può variare leggermente dalle dimensioni menzionate.

**NOTA:** Devido a variações na produção o tamanho real da montagem poderá variar ligeiramente das dimensões especificadas.

# FLOOR ASSEMBLY | MONTAGE DU SOL | ARMADO DEL PISO | MONTAGE DER BODENPLATTE | VLOERMONTAGE | MONTACCIO DEL PAVIMENTO | MONTAGEM DO PISO

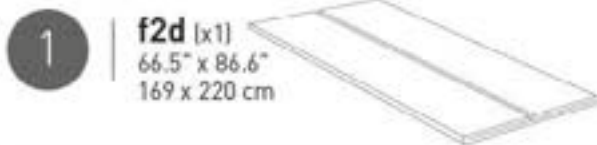

- Folded black panel
- Panneau noir à déplier
- Panel negro doblado
- Umgeklapptes, schwarzes paneel

- Gevouwen zwart paneel
- Piegato pannello nero
- Painel preto dobrado

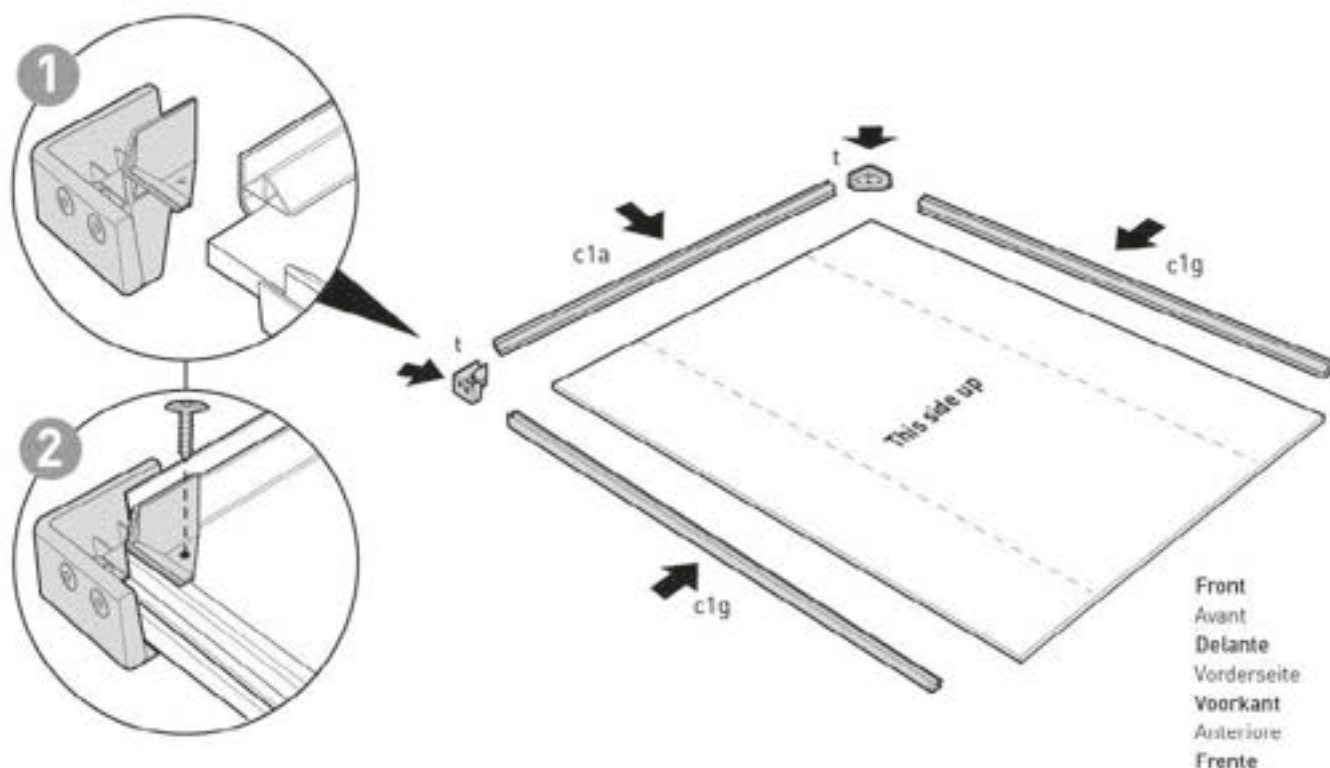
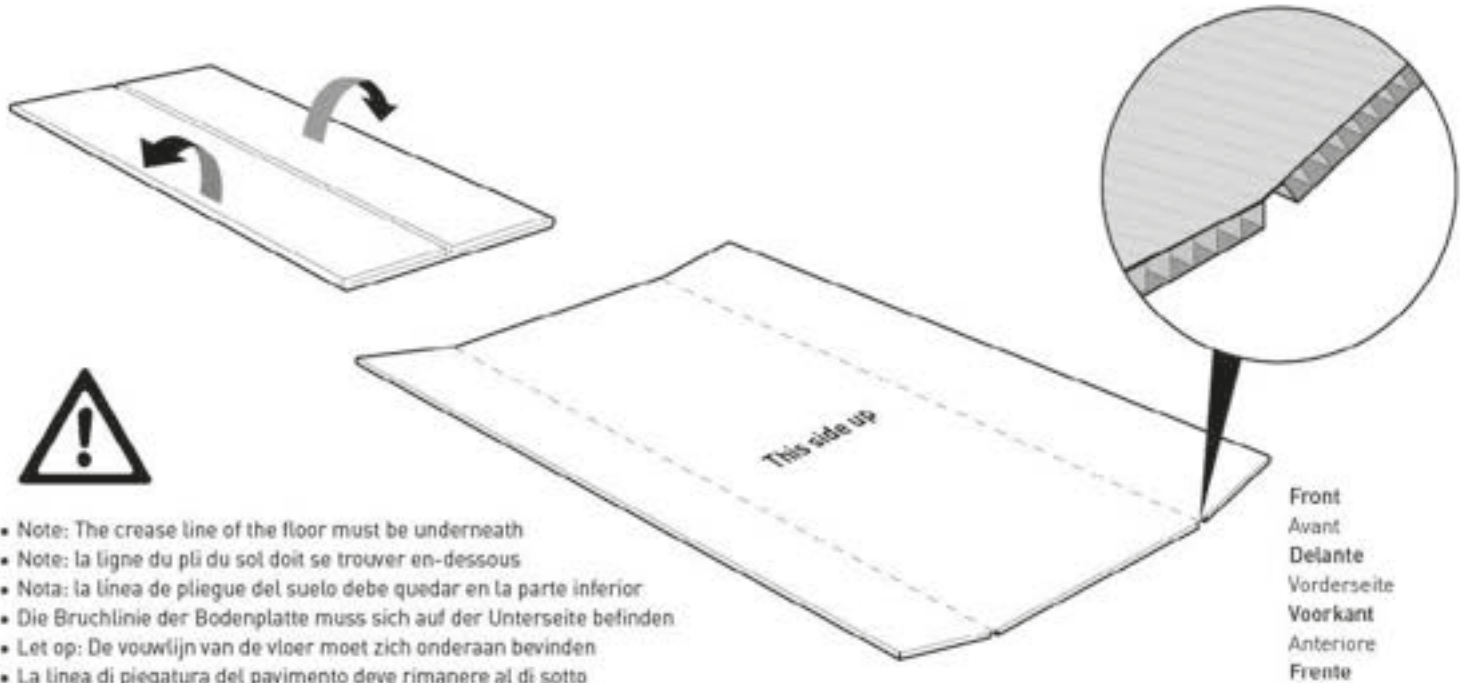

3

d1b (x1)



msl (x1)



msr (x1)

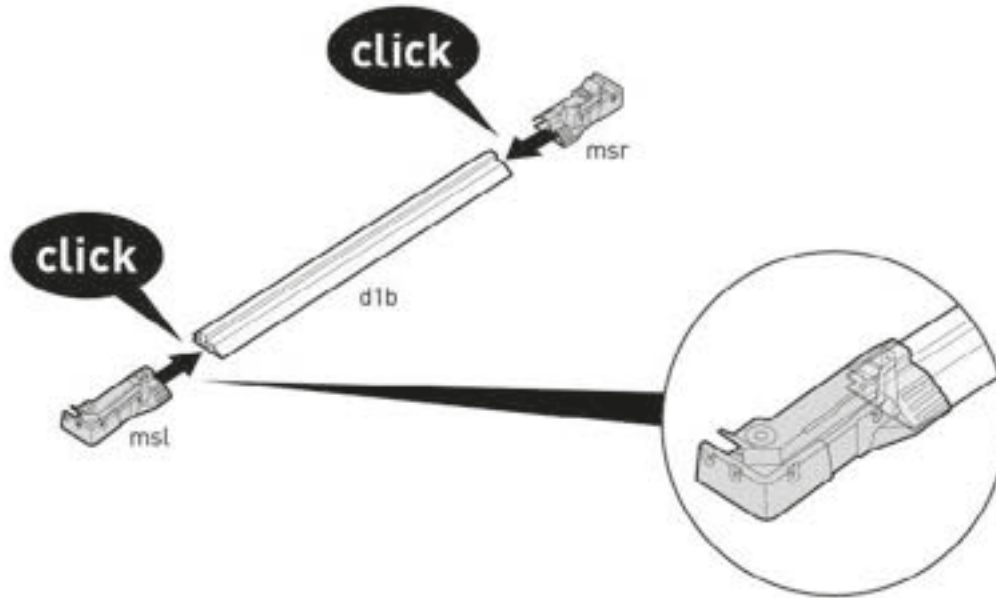

4

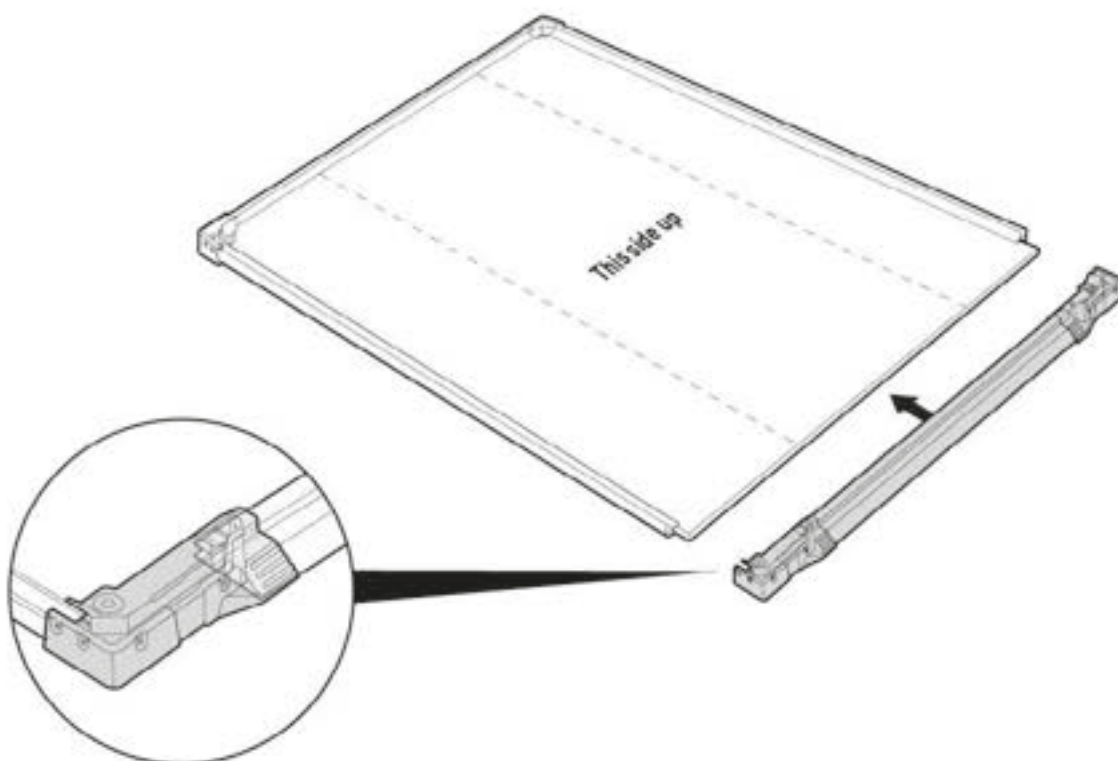



5

A

- Turn over the floor panel
- Retournez le panneau du sol
- Dé la vuelta al panel del suelo
- Drehen Sie die Bodenplatte um
- Draai het vloerpaneel om
- Capovolgli il pannello del pavimento
- Vire o painel do pavimento

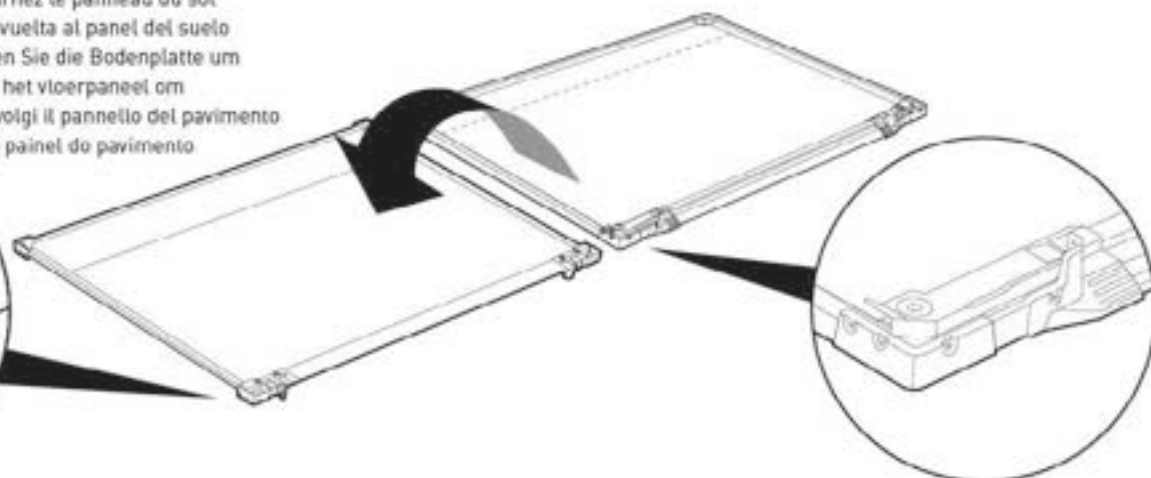
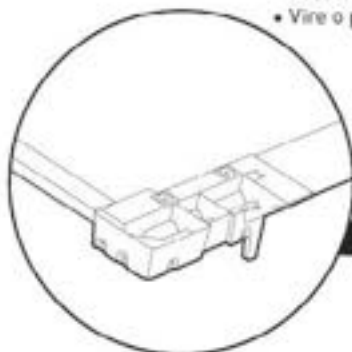

B

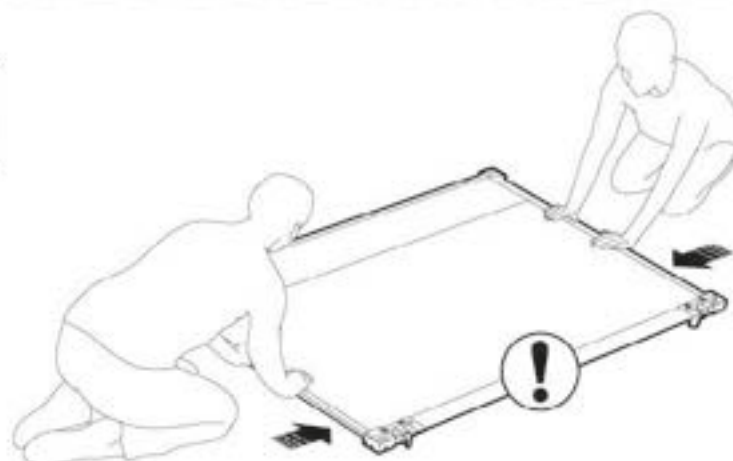

6

sc15 (x8)  
0.63"  
16 mm

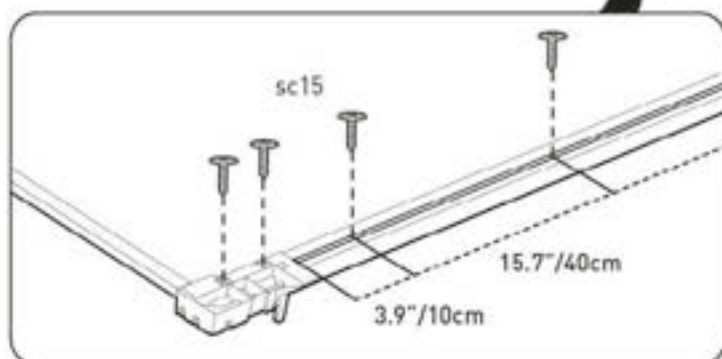
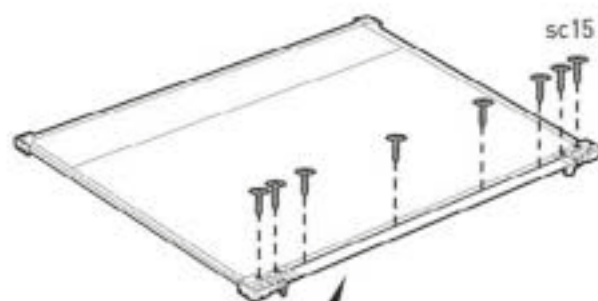

- Fit the panel inside the profile; screw on mark line
- Insérez le panneau à l'endroit prévu pour la vis sur la ligne dessinée
- Encaje el panel dentro del marco y atorníllelo en la línea marcada
- Verschrauben Sie die Bodenplatte an der markierten Linie auf dem Profil mit der Schraube
- Plaats het paneel binnen het profiel, schroef op de gemarkeerde lijn
- Inserite il pannelo nel profilo. Avvitare sulla linea guida
- Ajuste o Painel no Interior do Contorno. Aparafuse na linha Marcada.

7

**s26b** (x16)  
1"  
26 mm

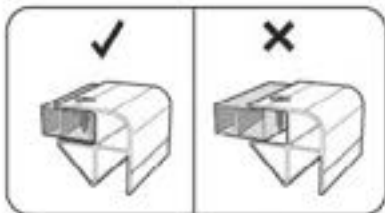
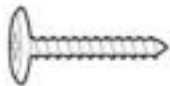

- Fully fit the panel inside the profile
- Fixez entièrement le panneau dans la découpe
- Coloque completamente el panel dentro del perfil
- Passen Sie das Panel genau und akkurat in das Profil ein
- Plaats het paneel volledig in het profiel
- Inserire correttamente il pannello all'interno delle guide
- Encaixe totalmente o painel dentro do contorno

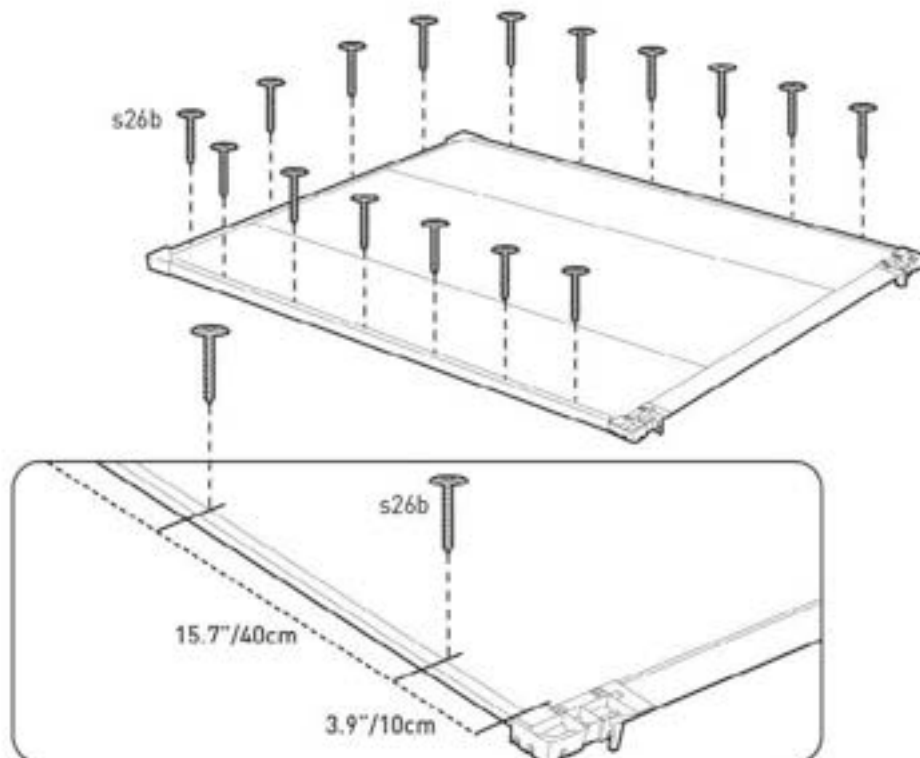

8

- Turn over the floor panel
- Retournez le panneau du sol
- Dé la vuelta al panel del suelo
- Drehen Sie die Bodenplatte um
- Draai het vloerpaneel om
- Capovolgi il pannello del pavimento
- Vire o painel do pavimento

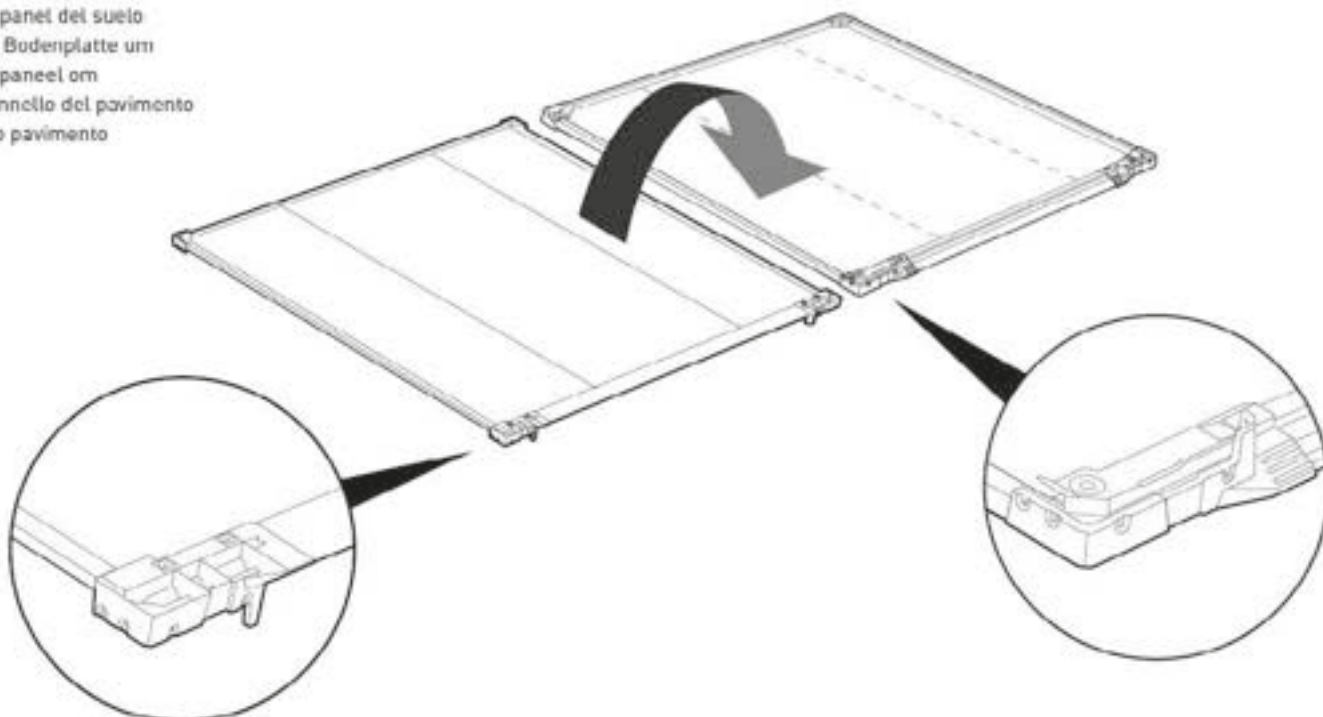

# WALL ASSEMBLY | MONTAGE DU MUR | ARMADO DE PAREDES | MONTAGE DER WÄNDE | MONTAGE VAN DE MUREN | ASSEMBLAGGIO DELLE PARETI | MONTAGEM DA PAREDE

- DECIDING ON THE LOCATION OF WINDOW
- EMBLACEMENT DES FENÊTRE
- DECIDIR LA UBICACIÓN DE LAS VENTANA
- BESTIMMUNG DER POSITION VON FENSTER
- OVER DE LOCATIE VAN RAMEN VENSTER
- SCEGLIERE LA POSIZIONE DELLE FINESTRA
- LOCALIZAÇÃO DAS JANELA

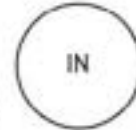

9

**c1b** (x1)  
73.2"  
186 cm



**bd1a** (x1)  
42.9" x 66.5"  
109 x 169 cm



- Use spatula (part "SPA") for easier insertion of panel into profile.
- Utilisez la spatule (partie « SPA ») pour une meilleure insertion du panneau dans le profil.
- Utilice una espátula (pieza "SPA") para una mejor inserción del panel en el perfil.
- Benutzen Sie den Spachtel (Bezeichnung „SPA“), um die Platten leichter in die Nut einführen zu können.
- Gebruik spatel (onderdeel SPA) voor het gemakkelijk invoeren van het paneel in het profiel.
- Utilizzare la spatola (parte SPA) per inserire il pannello più facilmente nel profilo.
- Utilize uma espátula (peça "SPA") para facilitar a inserção do painel no perfil.

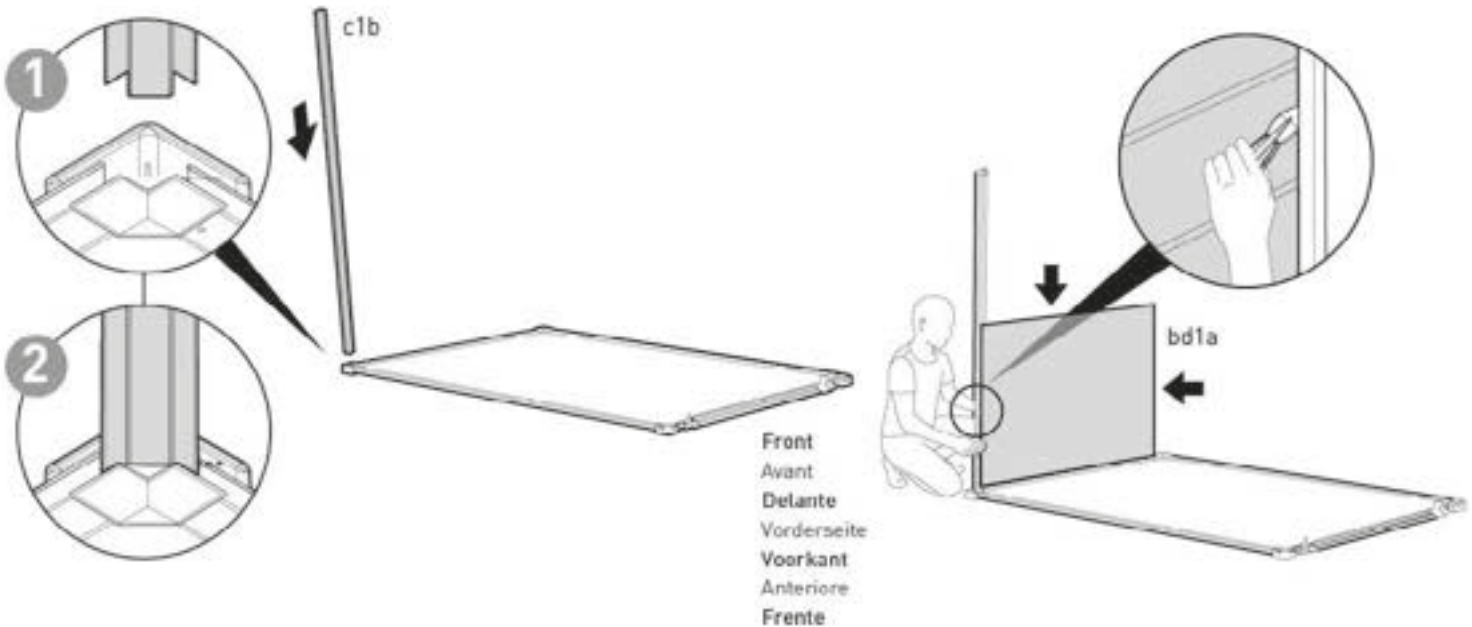

10

**w1c** (x1)  
39.8" x 73.6"  
101 x 187 cm

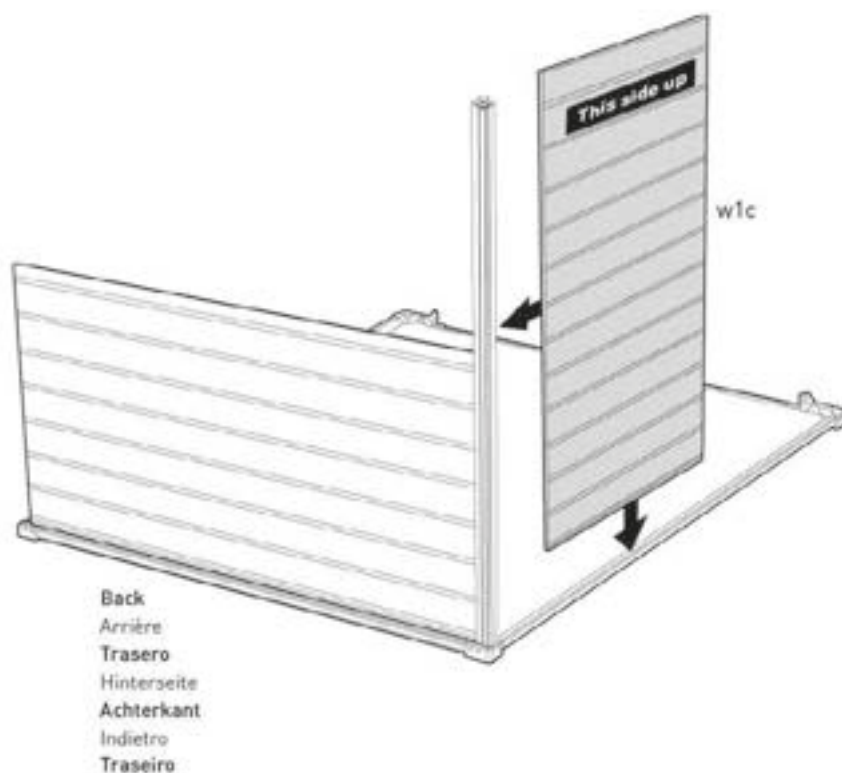

11

**s26b** (x8)  
1"  
26 mm

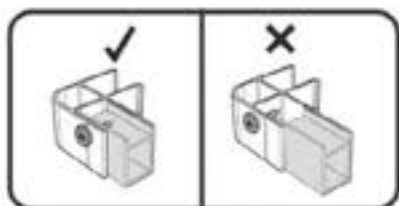
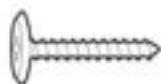

- Fully fit the panel inside the profile
- Fixez entièrement le panneau dans la découpe
- Coloque completamente el panel dentro del perfil
- Passen Sie das Panel genau und akkurat in das Profil ein
- Plaats het paneel volledig in het profiel
- Inserire correttamente il pannello all'interno delle guide
- Encaixe totalmente o painel dentro do contorno

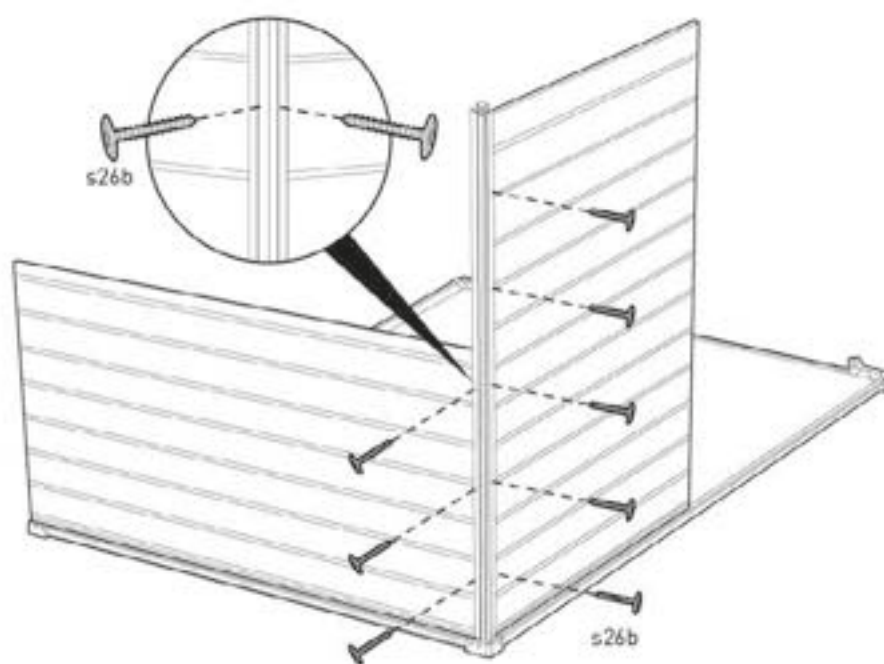

12

**h1b** (x1)  
65"  
165 cm

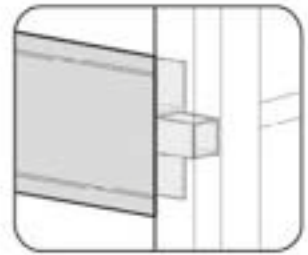
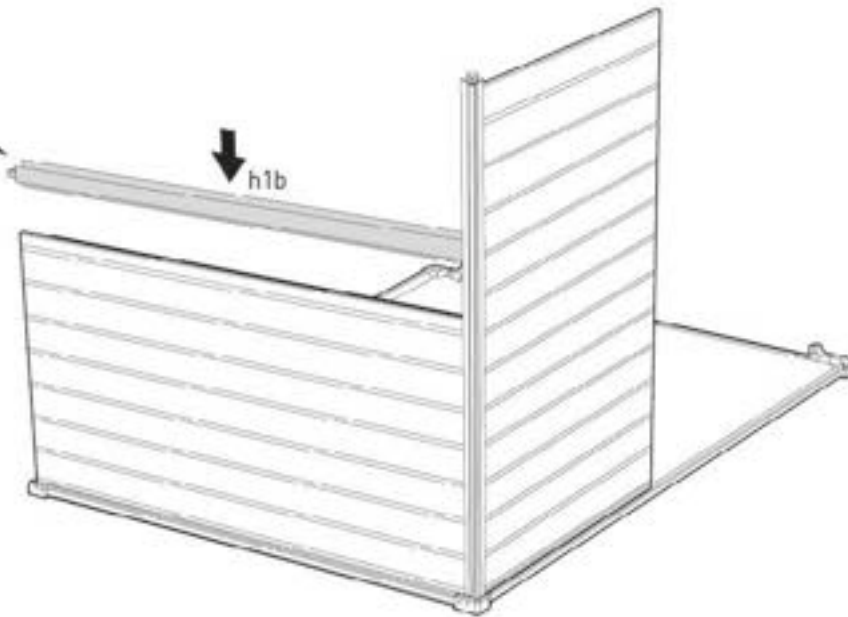
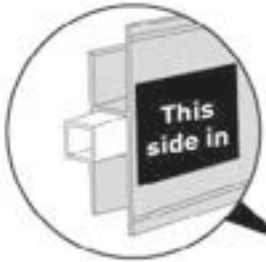

- Parts are tangent to one another
- Les parties sont tangentes les unes aux autres
- Las piezas son tangentes entre sí
- Die teile berühren einander
- Delen staan haaks op elkaar
- Le parti sono tangenti tra loro
- As peças são tangentes uma à outra

13

**c1b** (x1)  
73.2"  
186 cm



**bu1a** (x1)

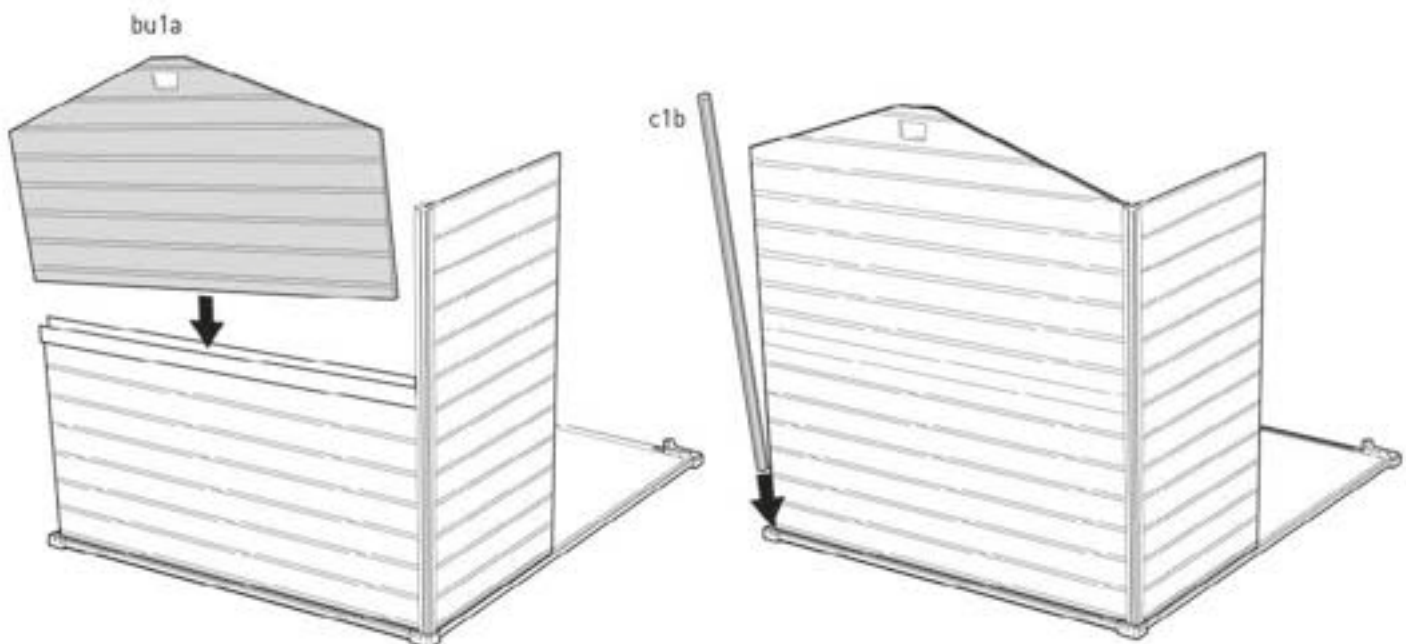

14

**s26b** (X7)  
1"  
26 mm

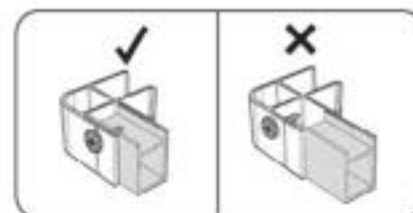
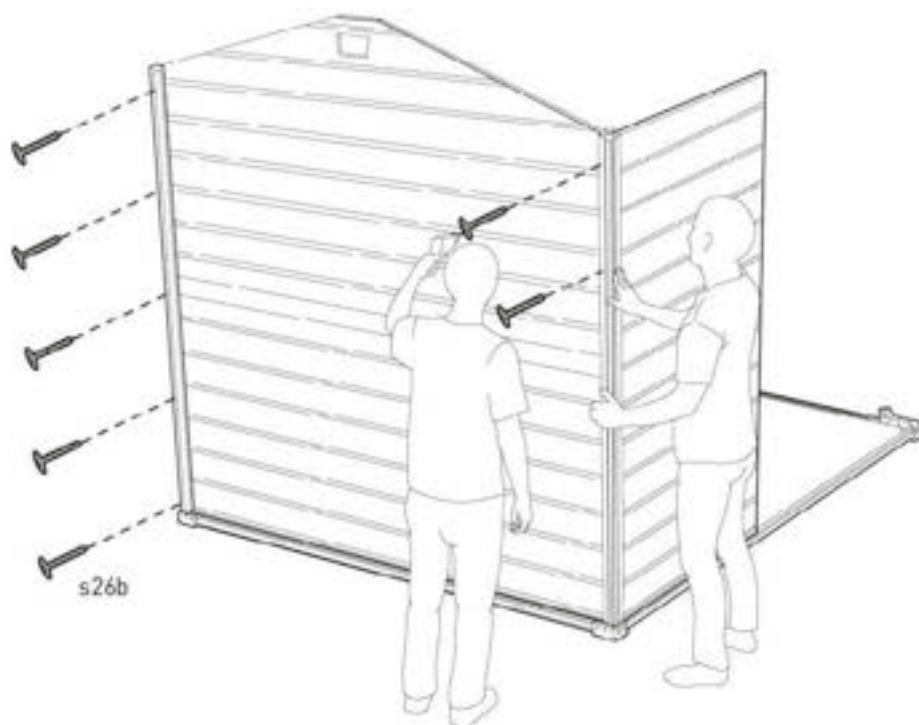
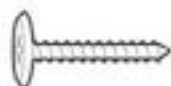

- Fully fit the panel inside the profile
- Fixez entièrement le panneau dans la découpe
- Coloque completamente el panel dentro del perfil
- Passen Sie das Panel genau und akkurat in das Profil ein
- Plaats het paneel volledig in het profiel
- Inserire correttamente il pannello all'interno delle guide
- Encaixe totalmente o painel dentro do contorno

15

**h1a** (x1)  
72.4"  
184 cm

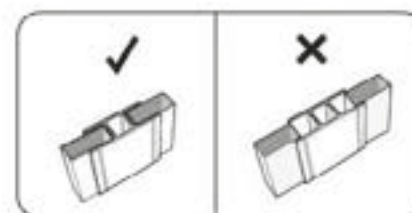
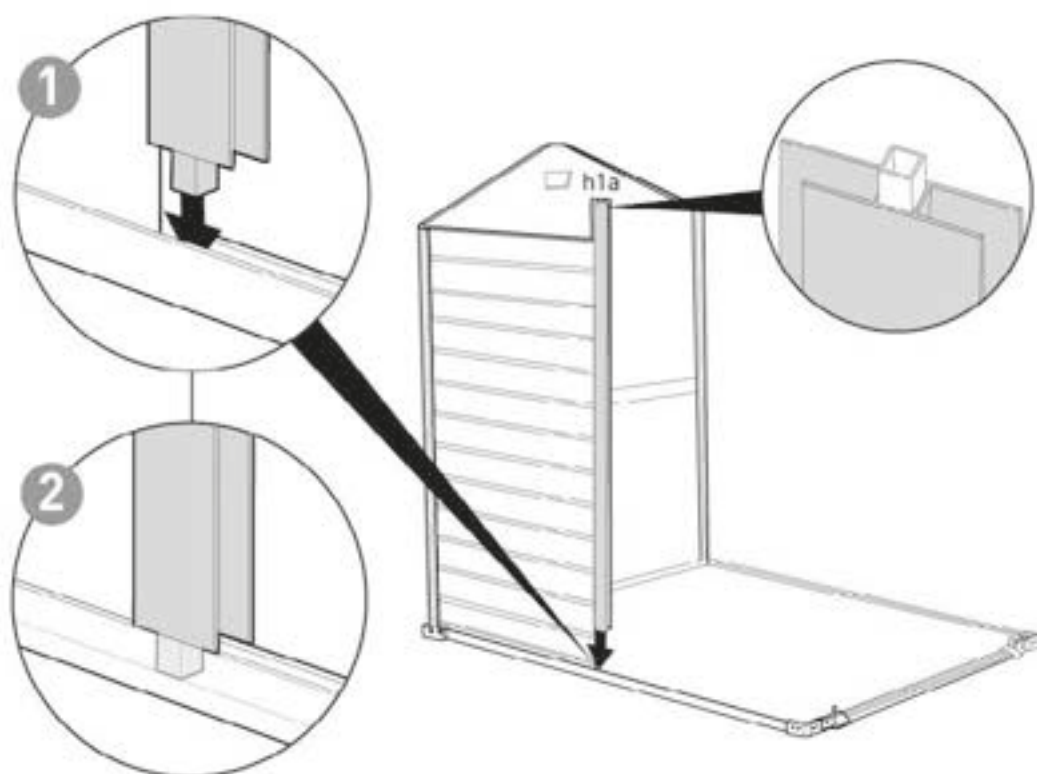

- Fully fit the panel inside the profile
- Fixez entièrement le panneau dans la découpe
- Coloque completamente el panel dentro del perfil
- Passen Sie das Panel genau und akkurat in das Profil ein
- Plaats het paneel volledig in het profiel
- Inserire correttamente il pannello all'interno delle guide
- Encaixe totalmente o painel dentro do contorno

16

**s1c** (x1)  
39.8" x 73.6"  
101 x 187 cm



**c1b** (x1)  
73.2"  
186 cm

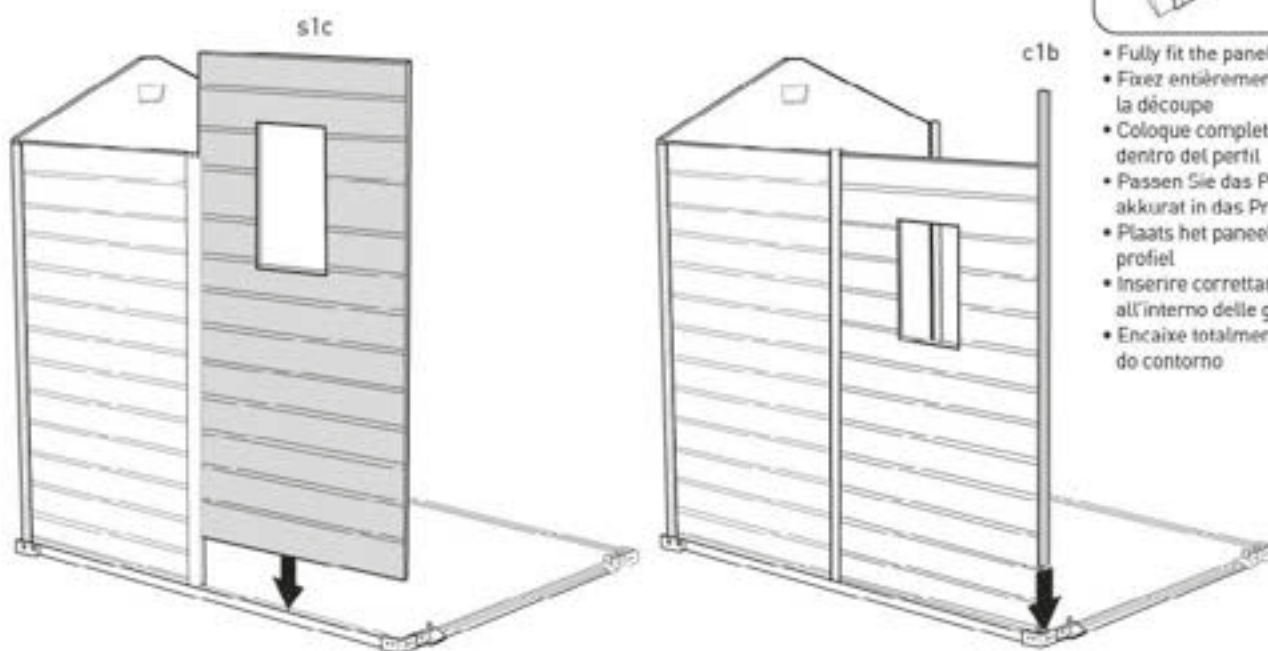
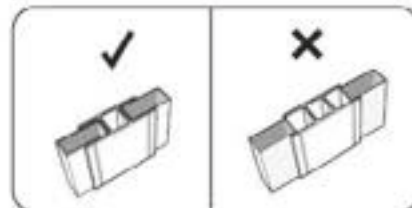

- Fully fit the panel inside the profile
- Fixez entièrement le panneau dans la découpe
- Coloque completamente el panel dentro del perfil
- Passen Sie das Panel genau und akkurat in das Profil ein
- Plaats het paneel volledig in het profiel
- Inserire correttamente il pannello all'interno delle guide
- Encaixe totalmente o painel dentro do contorno

17

**s13b** (x2)  
0.47"  
12 mm



**s26b** (x5)  
1"  
26 mm

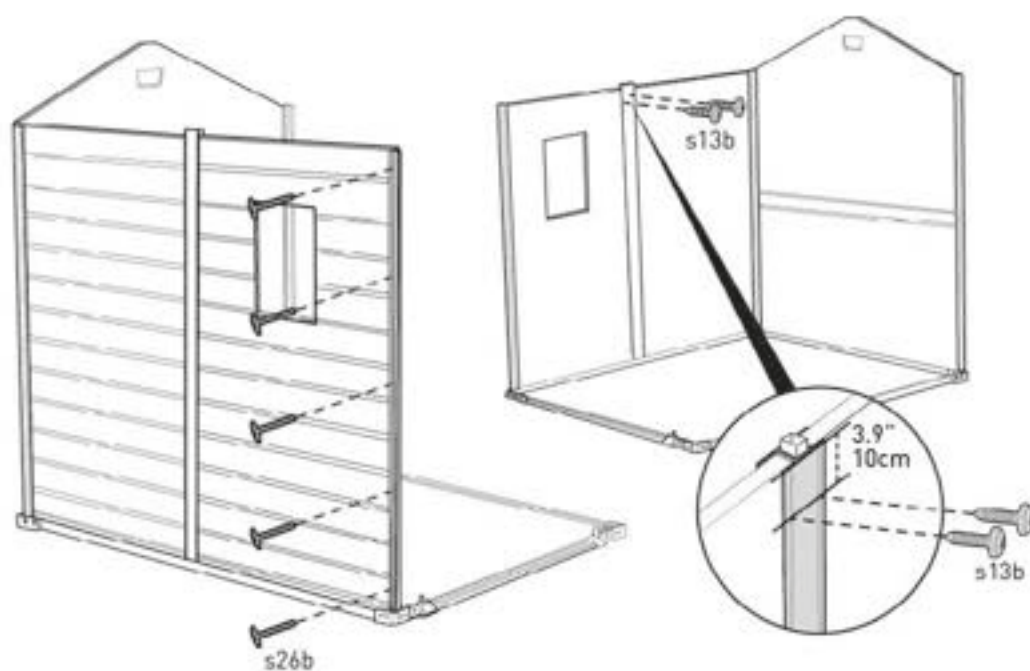
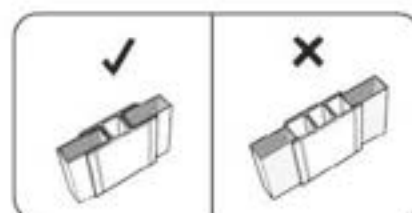

- Fully fit the panel inside the profile
- Fixez entièrement le panneau dans la découpe
- Coloque completamente el panel dentro del perfil
- Passen Sie das Panel genau und akkurat in das Profil ein
- Plaats het paneel volledig in het profiel
- Inserire correttamente il pannello all'interno delle guide
- Encaixe totalmente o painel dentro do contorno

18

**w1c** (x1)  
39.8" x 73.6"  
101 x 187 cm



**s26b** (x5)  
1"  
26 mm

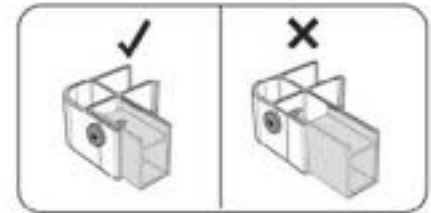
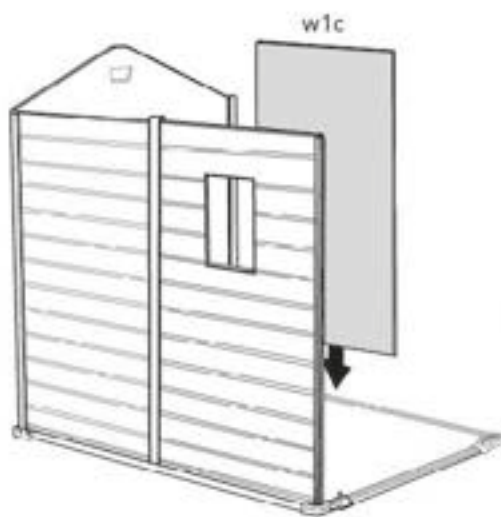

- Fully fit the panel inside the profile
- Fixez entièrement le panneau dans la découpe
- Coloque completamente el panel dentro del perfil
- Passen Sie das Panel genau und akkurat in das Profil ein
- Plaats het paneel volledig in het profiel
- Inserire correttamente il pannello all'interno delle guide
- Encaixe totalmente o painel dentro do contorno

19

**h1a** (x1)  
72.4"  
184 cm



**w1c** (x1)  
39.8" x 73.6"  
101 x 187 cm

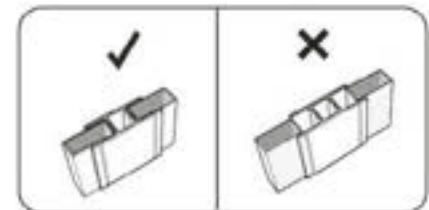
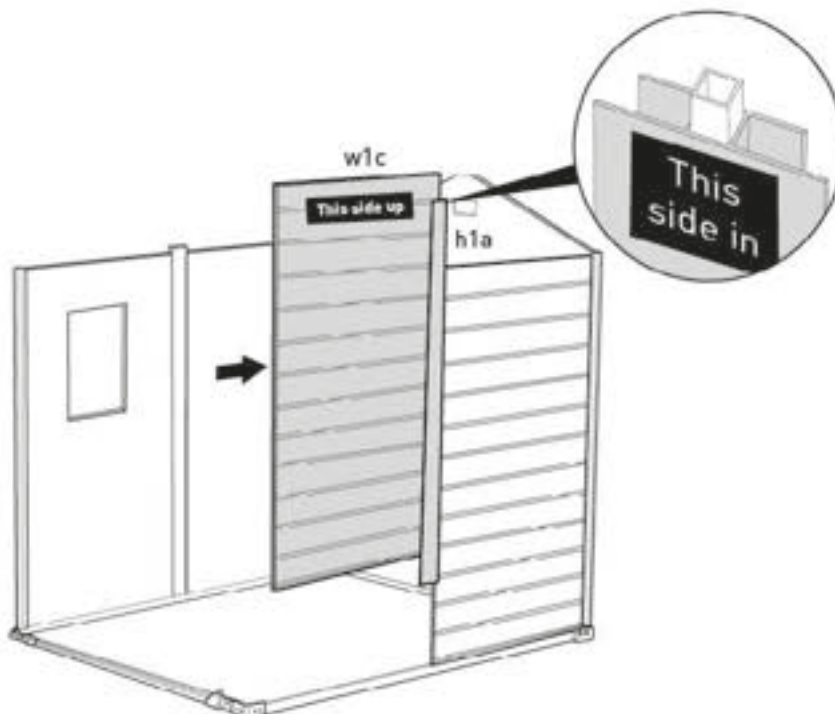

- Fully fit the panel inside the profile
- Fixez entièrement le panneau dans la découpe
- Coloque completamente el panel dentro del perfil
- Passen Sie das Panel genau und akkurat in das Profil ein
- Plaats het paneel volledig in het profiel
- Inserire correttamente il pannello all'interno delle guide
- Encaixe totalmente o painel dentro do contorno



20

**c1b** (x1)  
73.2"  
186 cm



**s13b** (x2)  
0.47"  
12 mm



**s26b** (x5)  
1"  
26 mm

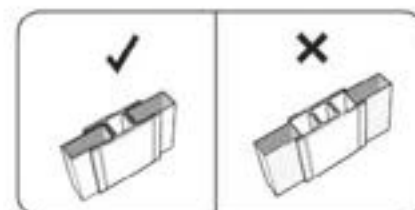
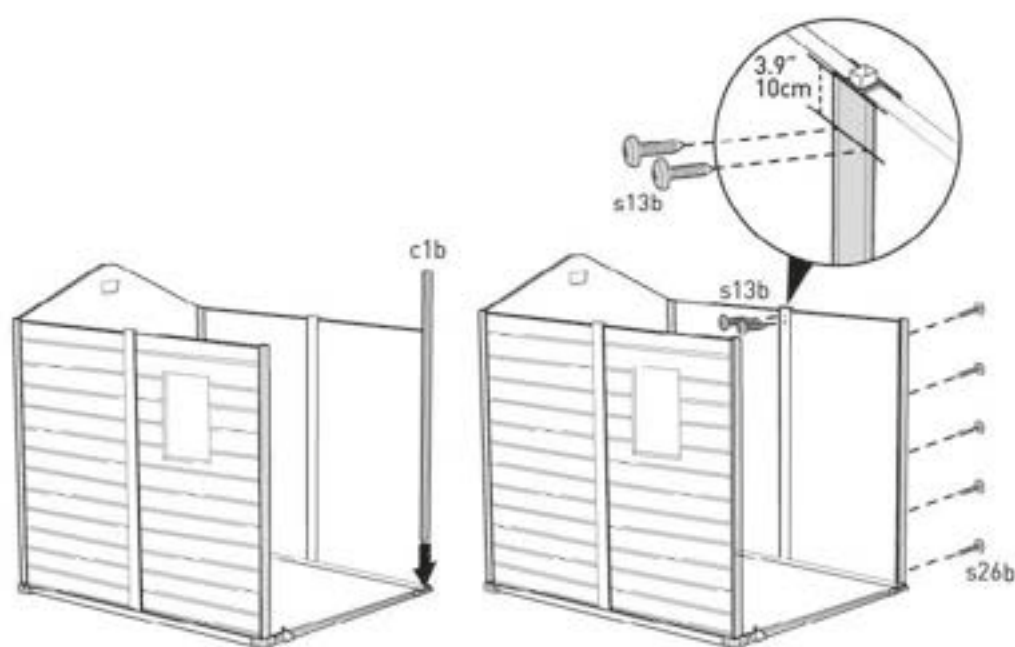
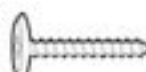

- Fully fit the panel inside the profile
- Fixez entièrement le panneau dans la découpe
- Coloque completamente el panel dentro del perfil
- Passen Sie das Panel genau und akkurat in das Profil ein
- Plaats het paneel volledig in het profiel
- Inserire correttamente il pannello all'interno delle guide
- Encaixe totalmente o painel dentro do contorno

FRONT WALL & DOOR FRAME ASSEMBLY | ASSEMBLAGE DU MUR DE DEVANT ET DU CADRE DE LA PORTE | MONTAJE DEL MARCO DE LA PUERTA Y DE LA PARED FRONTAL | MONTAGE DER VORDEREN WAND & DES TÜRRAHMENS | MONTEREN VOORSTE MUUR EN DEURFRAME | ASSEMBLAGGIO DEL MURO FRONTALE E DEL TELAIO DELLA PORTA | MONTAGEM DA PAREDE FRONTAL E DA ESTRUTURA DA PORTA

21

**fd2b** (x2)  
6.7" x 51.5"  
17 x 131 cm



**s26b** (x6)  
1"  
26 mm

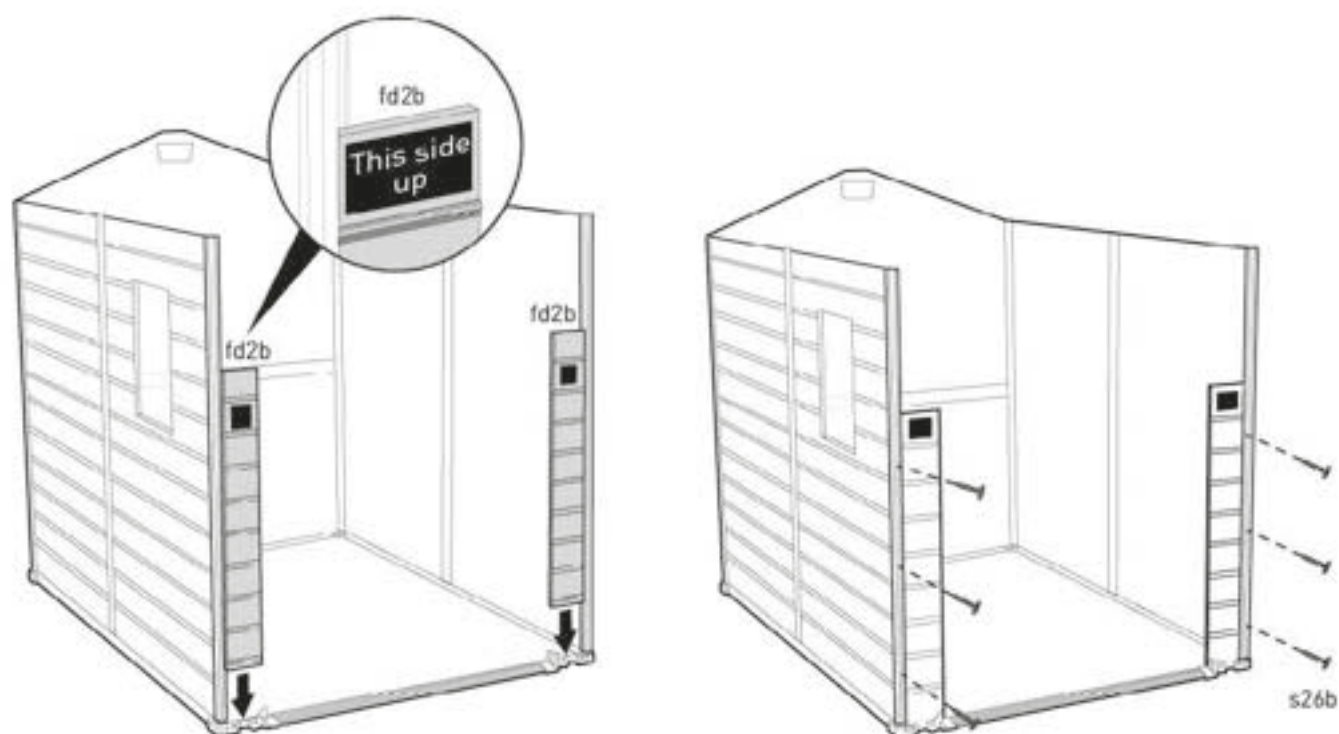
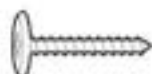

22

lm (x1)

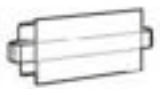

rm (x1)



Left  
Gauche  
Izquierdo  
Verließ  
Links  
Sinistra  
esquerdo

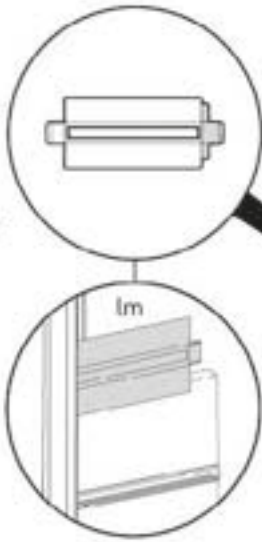

Right  
Droit  
Derecho  
Richtig  
Rechts  
Destra  
Direito

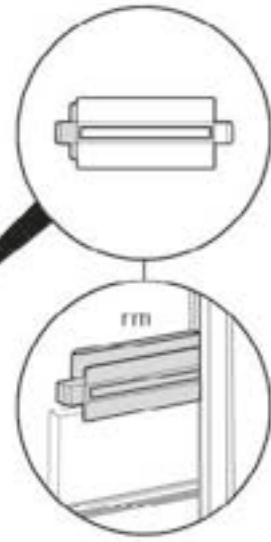

23

fu2a (x1)



s26b (x4)

1"  
26 mm

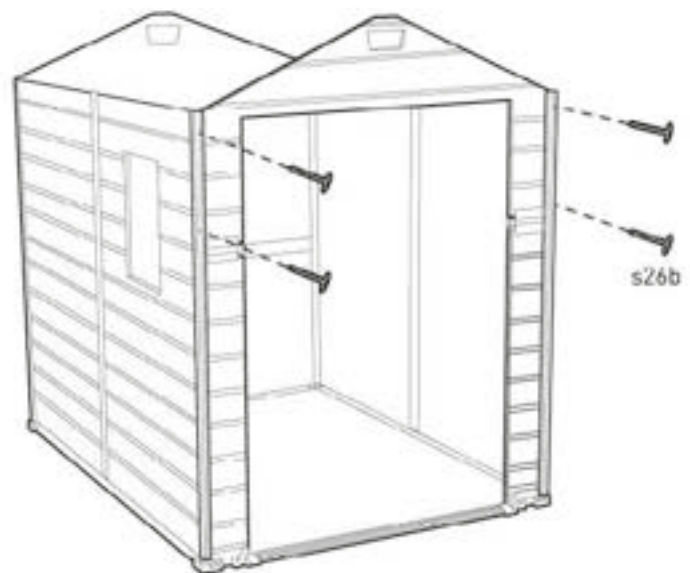
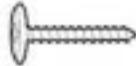

24

**mdfl** (x1)  
70.4"  
179 cm



Self drill screw  
**ds2b** (x1)  
0.39"  
10 mm

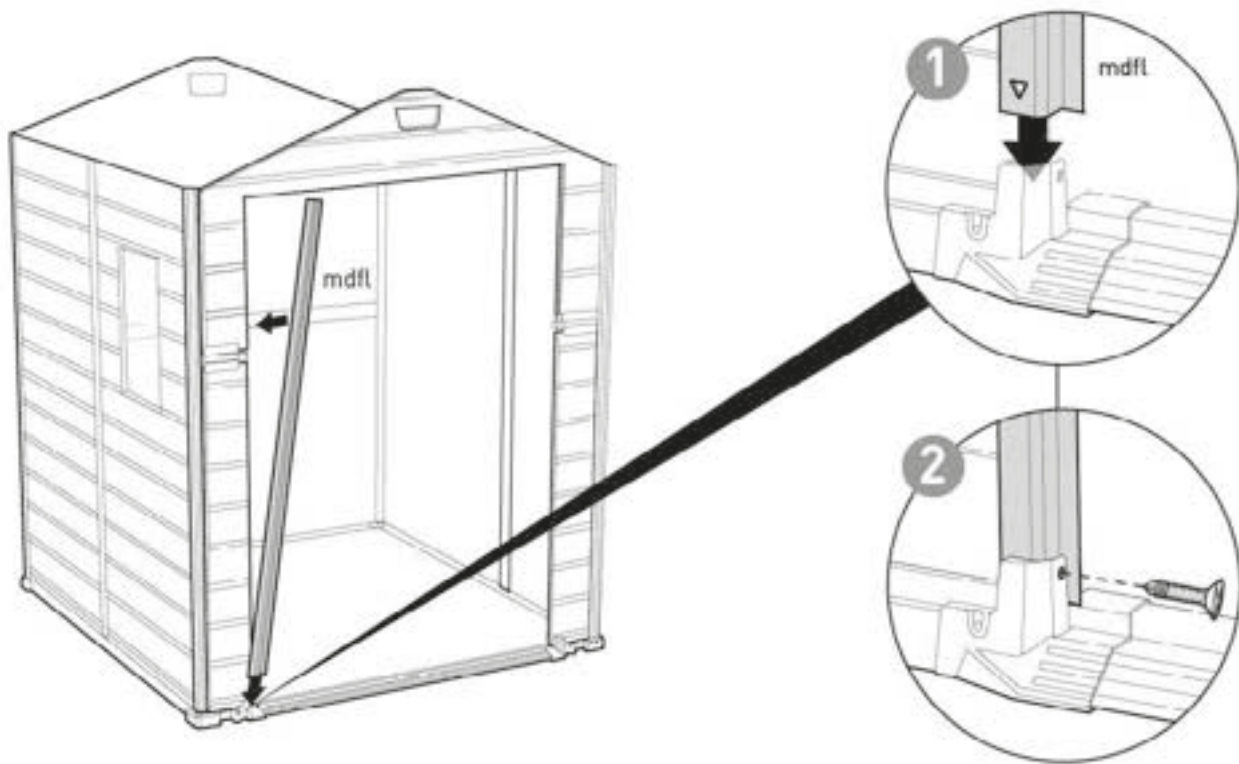

25

**mdfr**(x1)  
70.4"  
179 cm



Self drill screw  
**ds2b** (x1)  
0.39"  
10 mm

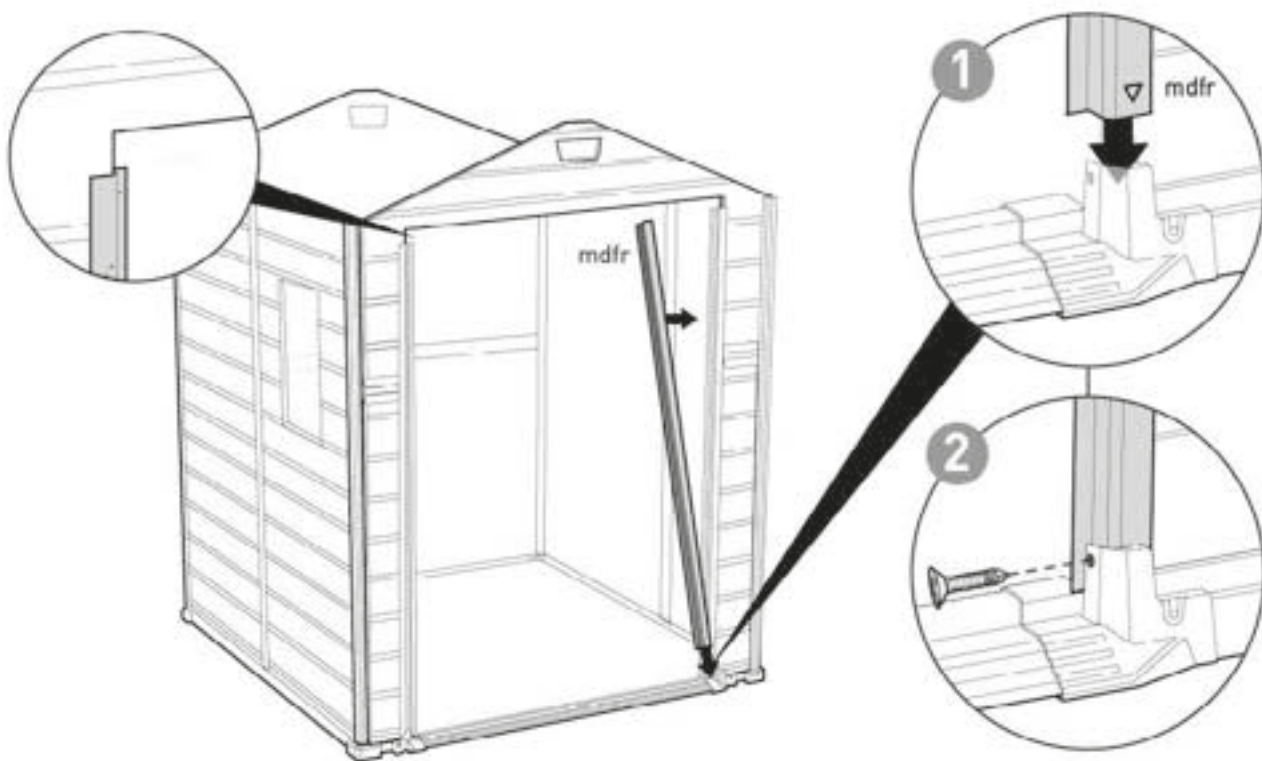

26

**mtm** [x1]  
53.1"  
135 cm

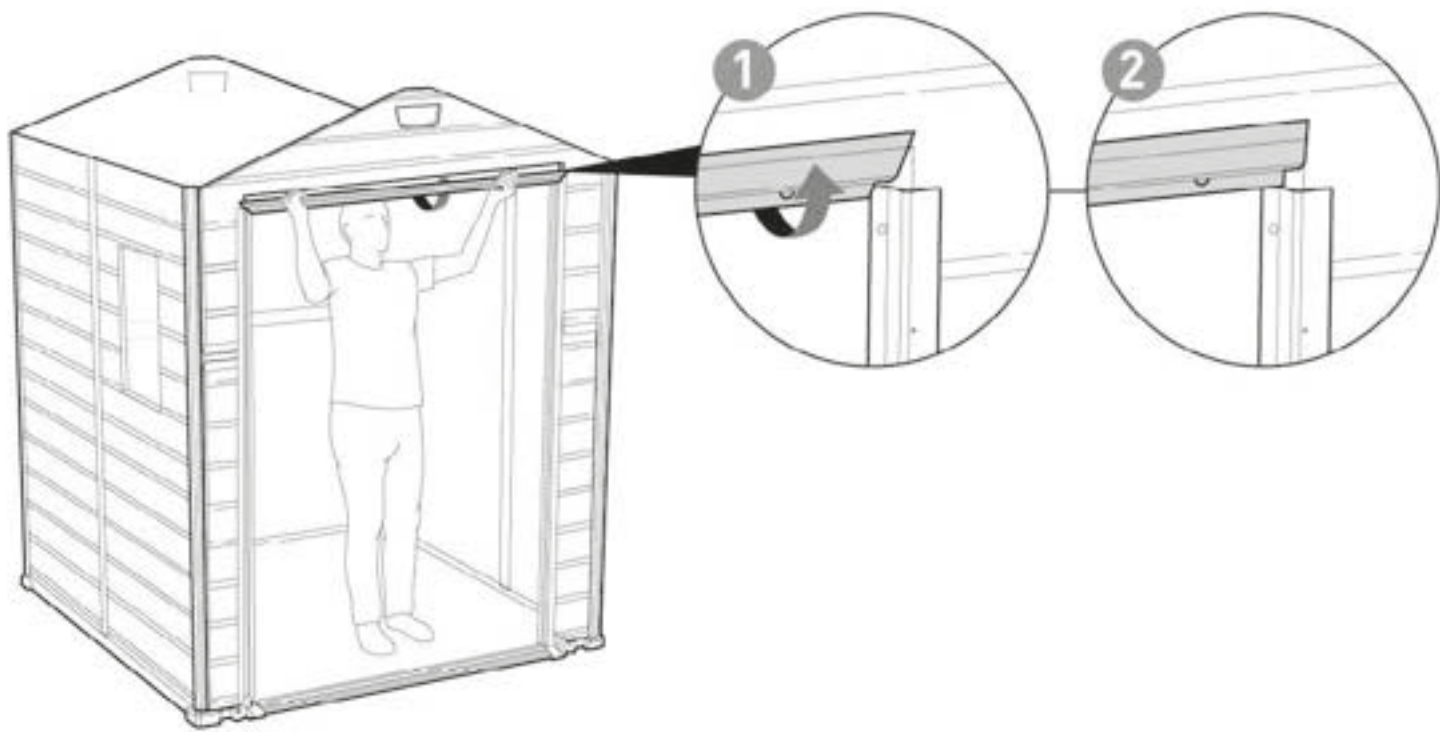

27

Self drill screw  
**ds2b** [x8]  
0.39"  
10 mm



**mdt** [x2]

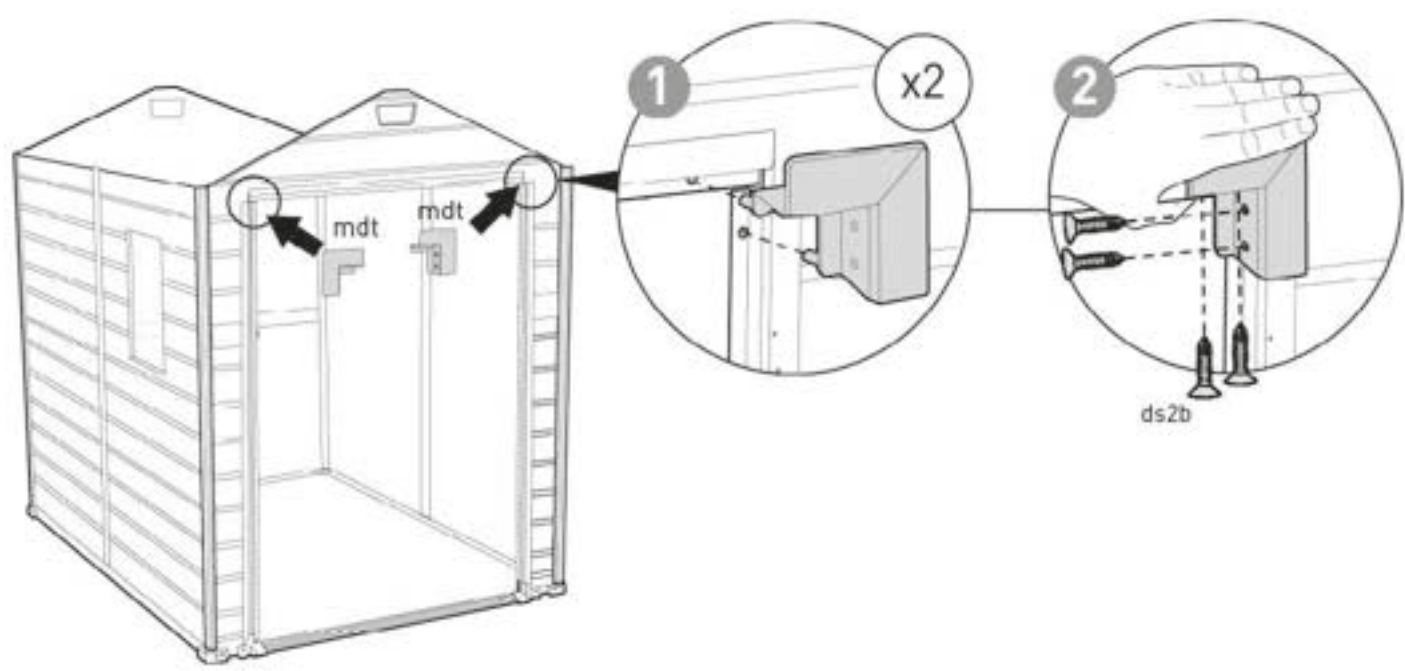

28

**s50b** (x2)  
1.97"  
50 mm

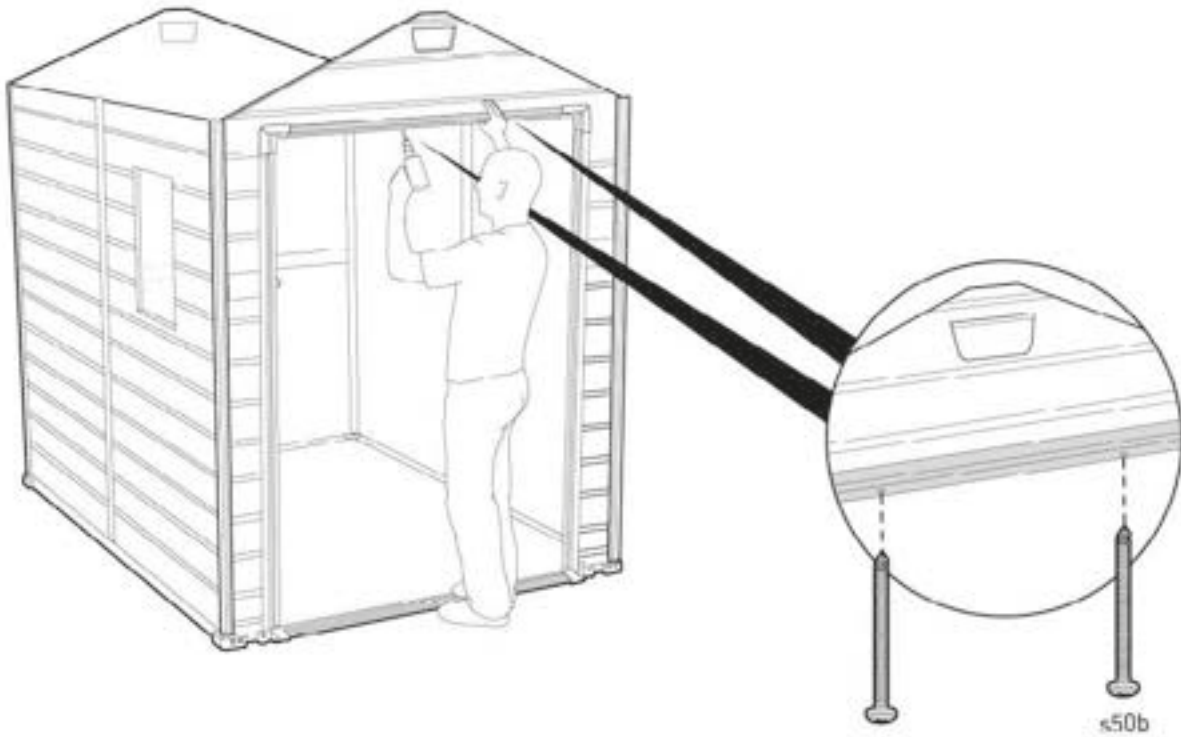

29

Self drill screw  
**s10b** (x8)  
0.47"  
12 mm

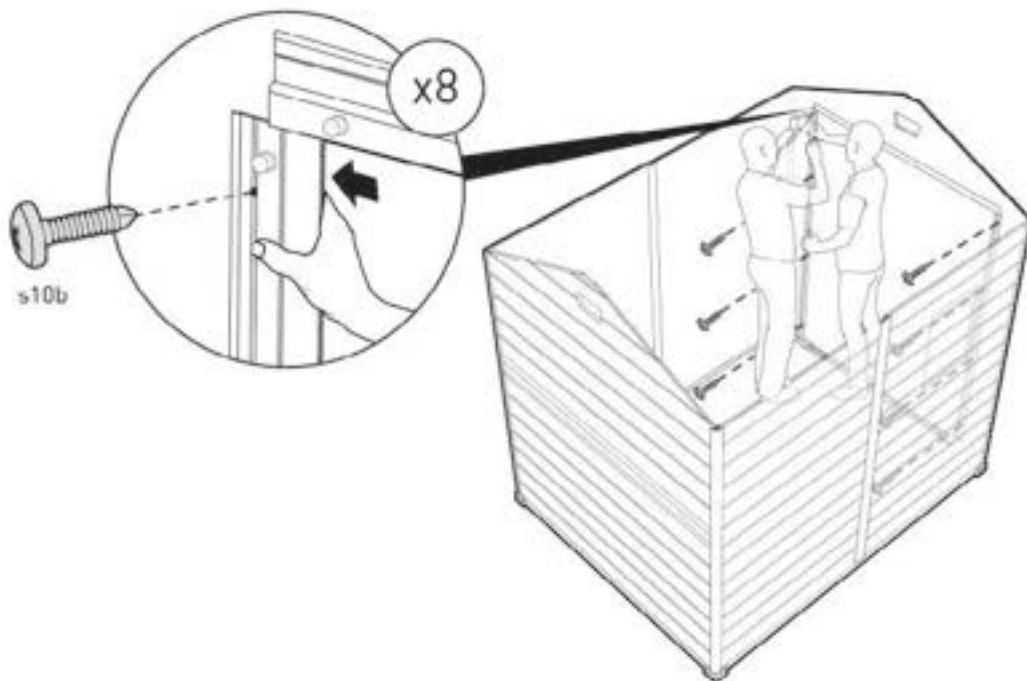

**30** | **s26b** (x16)  
1"  
26 mm

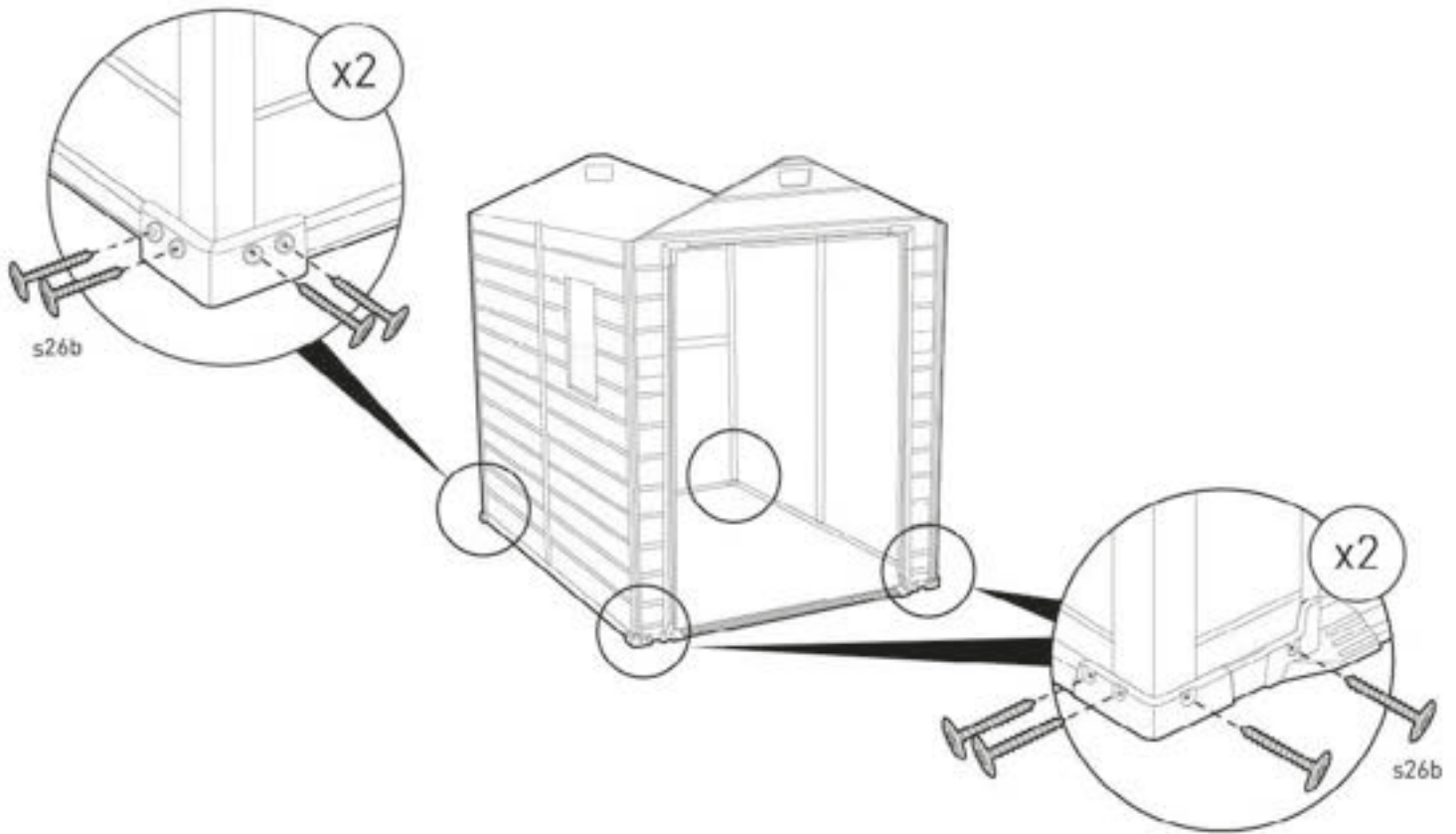
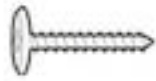

**31** | **s26b** (x12)  
1"  
26 mm

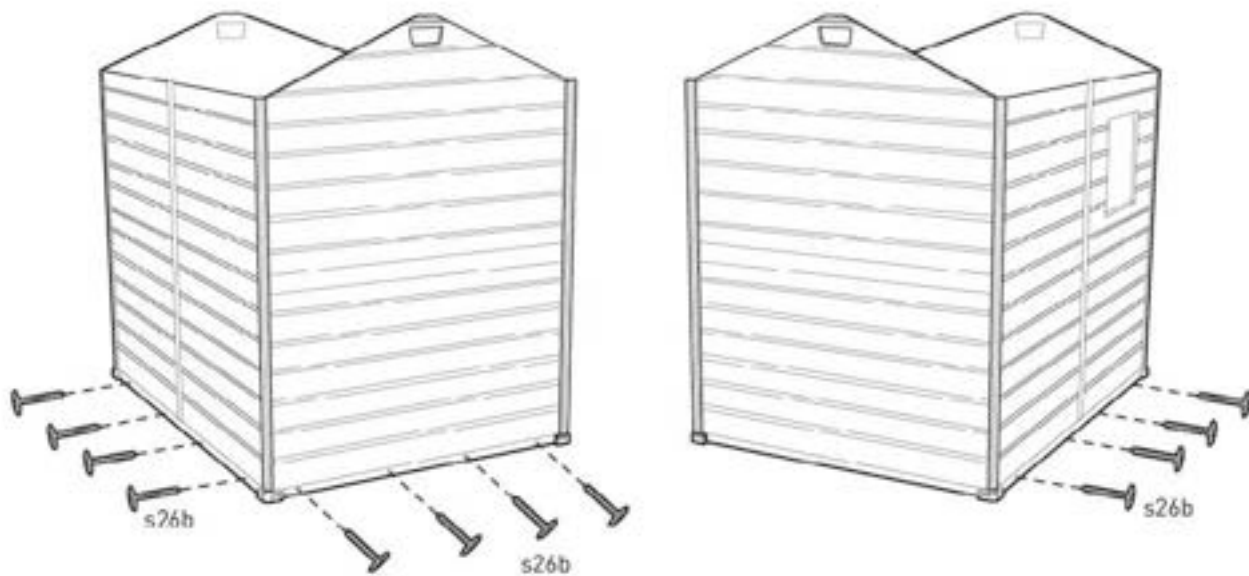

ROOF ASSEMBLY | MONTAGE DU TOIT | ARMADO DEL TECHO | DACHMONTAGE | DAKMONTAGE |  
MONTAGGIO DEL TETTO | MONTAGEM DO TELHADO

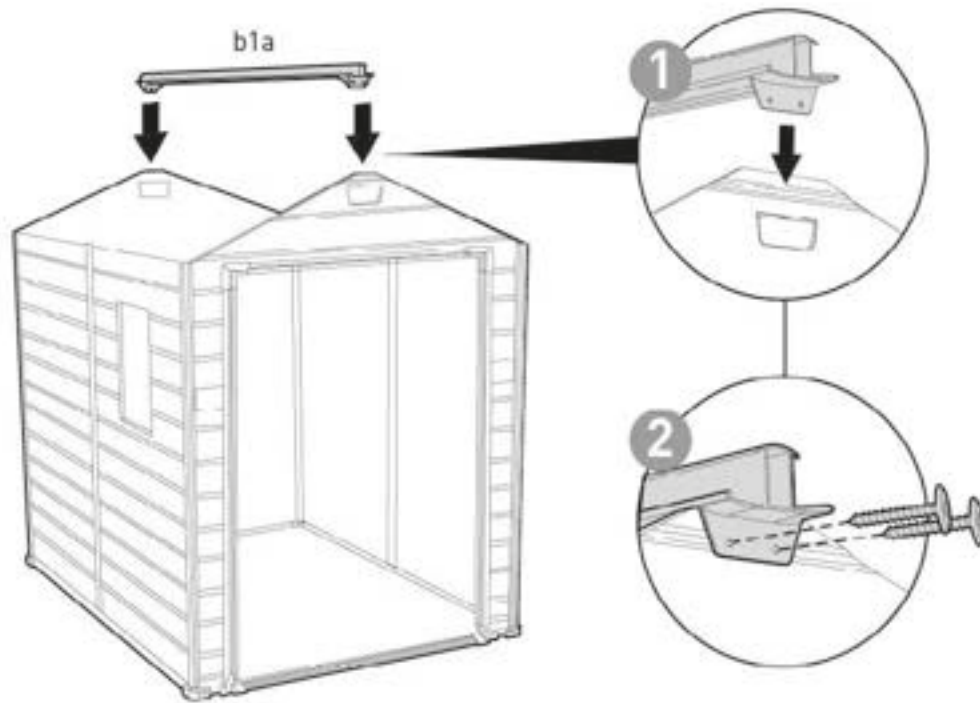

- Note: The roof fold line and the "This side down" label must be facing up as seen depicted in this figure
- La pliure du toit et l'étiquette "This Side Down" doivent être tournées vers le haut comme le montre cette figure
- La línea de dobléz del techo y la etiqueta "This side down" deben estar hacia arriba como se puede ver en esta imagen
- Die Knickkante des Daches und der „This Side Down“-Aufkleber müssen wie im unteren Bild dargestellt nach oben zeigen
- De vouwtlijn van het dak en het "This Side Down" label moeten naar boven liggen, zoals te zien is op de afbeelding
- La piega del tetto e l'etichetta "This Side Down" devono essere rivolti verso l'alto come indicato in questa figura
- A Linha do Vinco do Telhado e a Etiqueta "This side down" Devem Estar Viradas Para Cima Como Ilustrado Nesta Figura

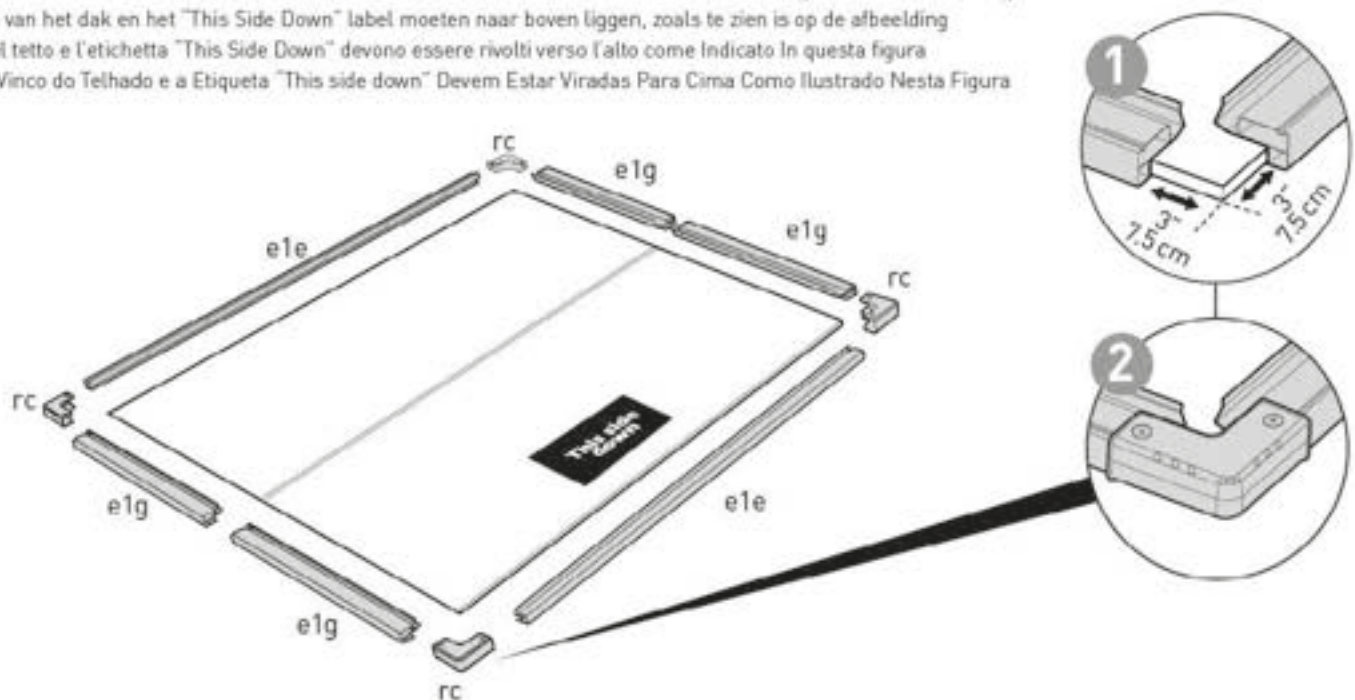

34

**s26b** (x8)  
1"  
26 mm

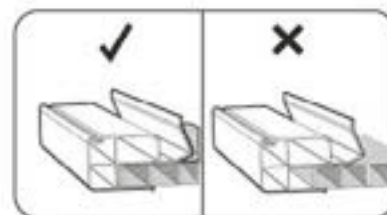
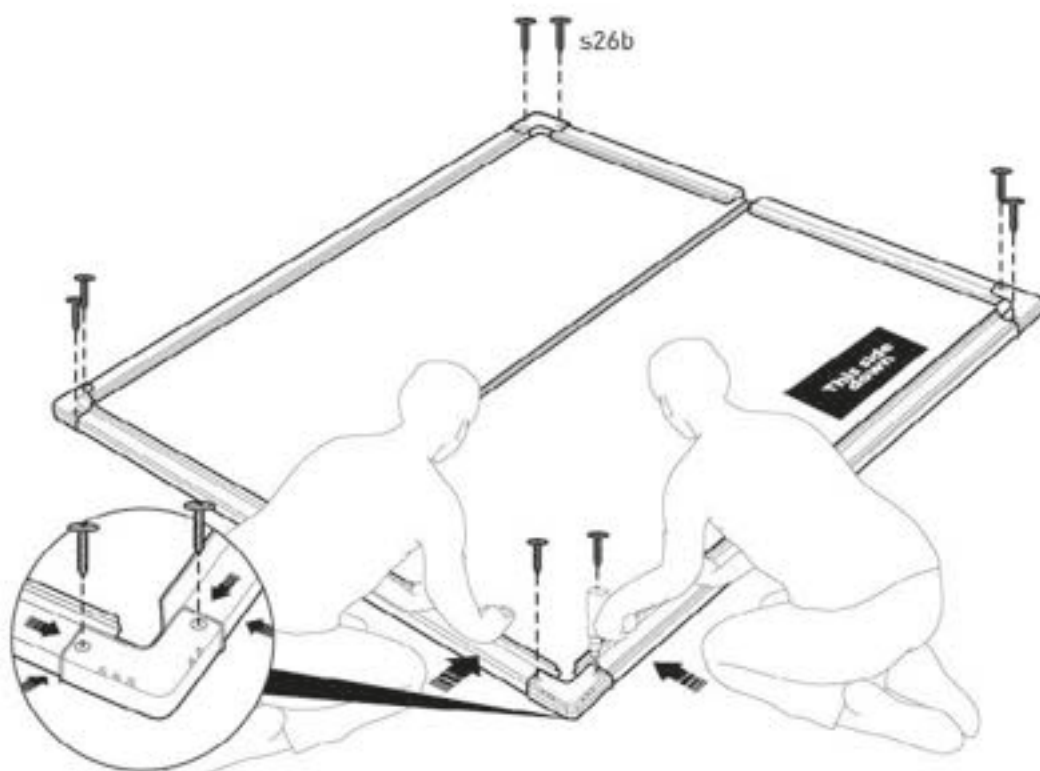
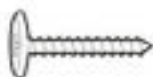

- Fully fit the panel inside the profile
- Fixez entièrement le panneau dans la découpe
- Coloque completamente el panel dentro del perfil
- Passen Sie das Panel genau und akkurat in das Profil ein
- Plaats het paneel volledig in het profiel
- Inserire correttamente il pannello all'interno delle guide
- Encaixe totalmente o painel dentro do contorno

35

- Turn over the roof panel
- Retourner le panneau supérieur
- Dale la vuelta al panel del techo
- Platte für das Dach umklappen
- Draai het dakpaneel om
- Capovolgli il pannello del tetto
- Voite o painel do telhado

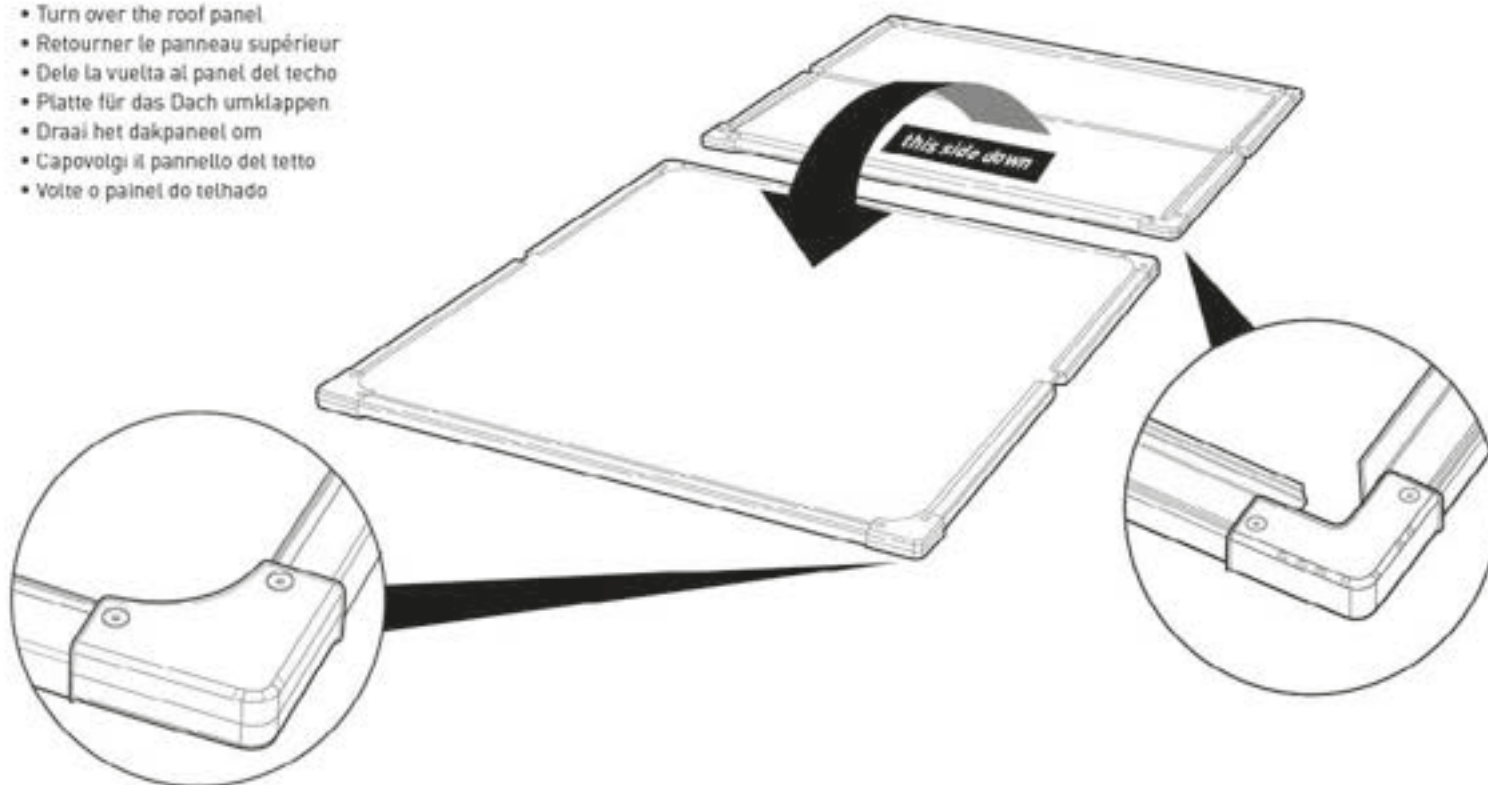



36

**s26b** (x24)  
1"  
26 mm

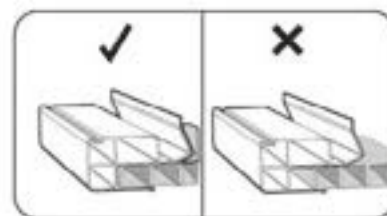
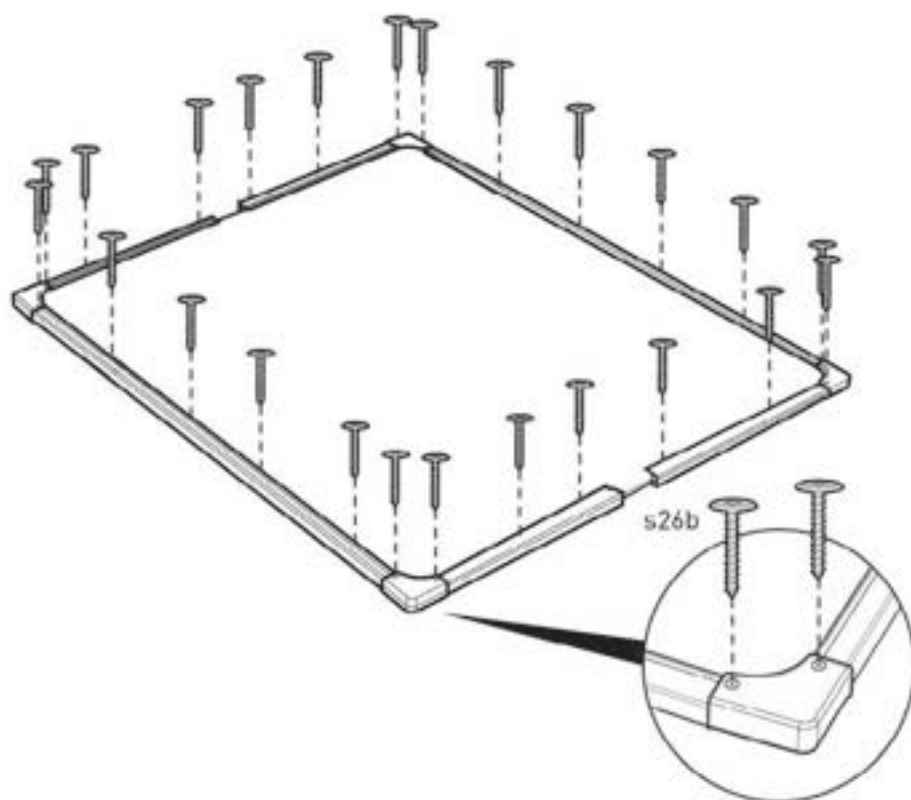
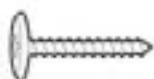

- Fully fit the panel inside the profile
- Fixez entièrement le panneau dans la découpe
- Coloque completamente el panel dentro del perfil
- Passen Sie das Panel genau und akkurat in das Profil ein
- Plaats het paneel volledig in het profiel
- Inserire correttamente il pannello all'interno delle guide
- Encaixe totalmente o painel dentro do contorno

37

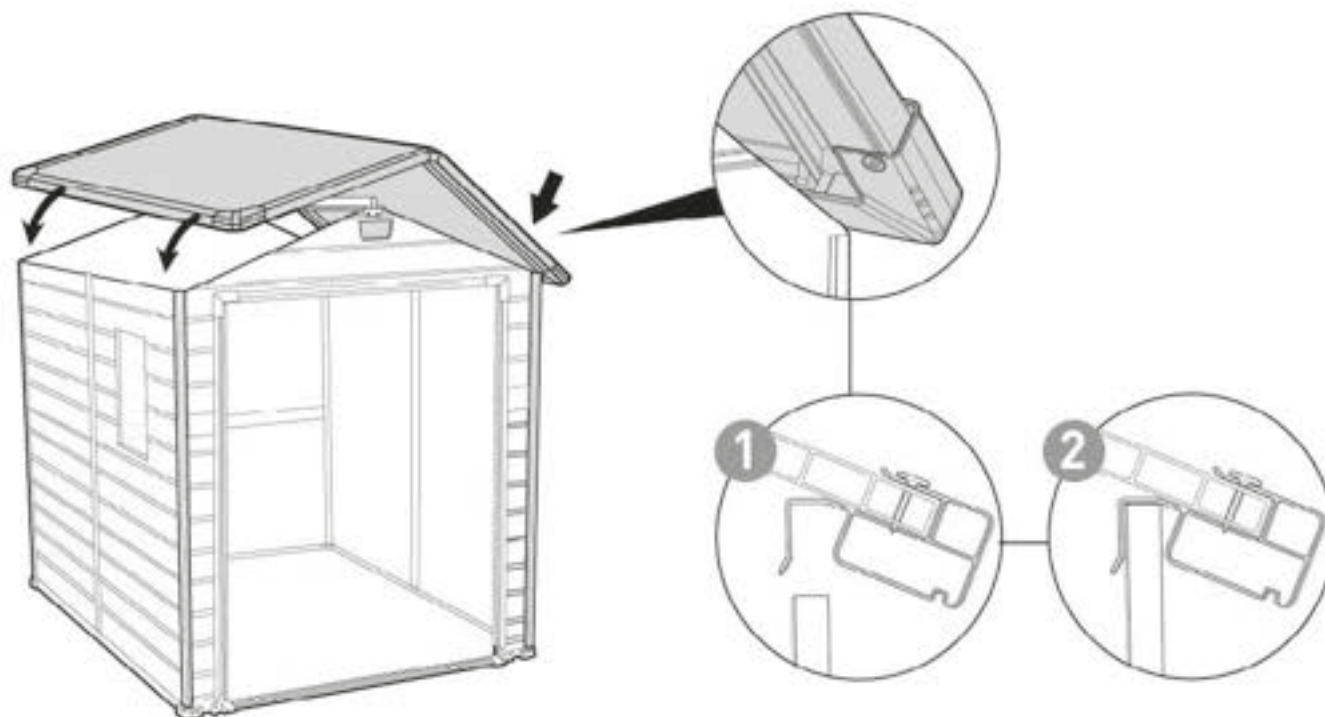

38

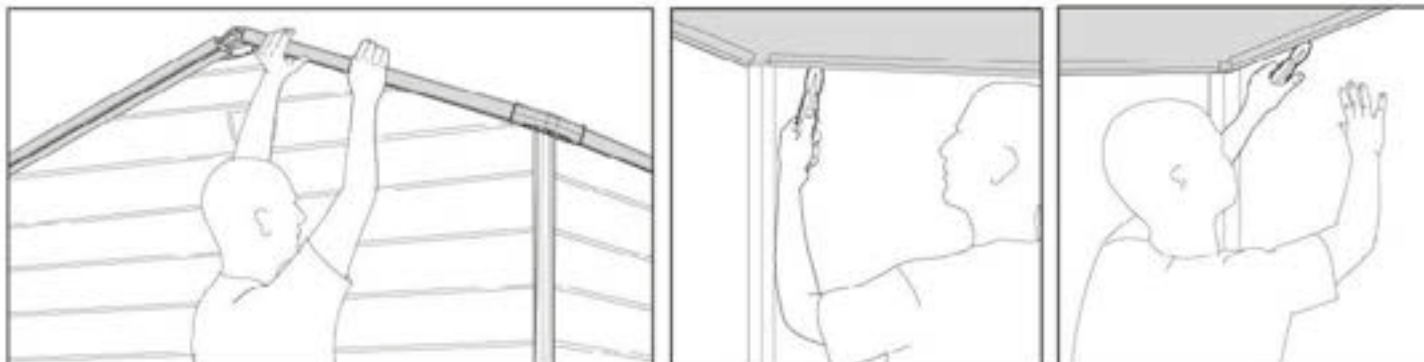

- Ensure roof is set fully down; use spatula as shown in the figure
- Assurez-vous que le toit est bien entièrement posé ; utilisez la spatule comme le montre la figure
- Asegúrese de que el techo esté completamente encajado abajo: utilice la espátula como lo muestra la figura
- Vergewissern Sie sich, dass das Dach vollständig aufgesetzt ist. Benutzen Sie den Spachtel wie in der Zeichnung dargestellt
- Verzeker u ervan dat het dak volledig naar beneden is: Gebruik het spatelwerktuig zoals getoond op de afbeelding
- Assicurati che il tetto sia completamente inserito fino in fondo. Usa la spatola come mostrato in Figura
- Certifique-se de que o telhado está completamente ajustado; Utilize a espátula como indicado na figura

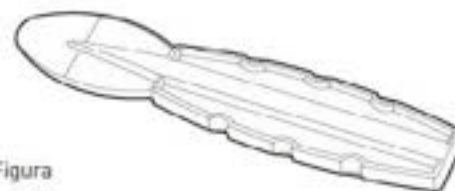

39

ac (x2)



ap (x1)

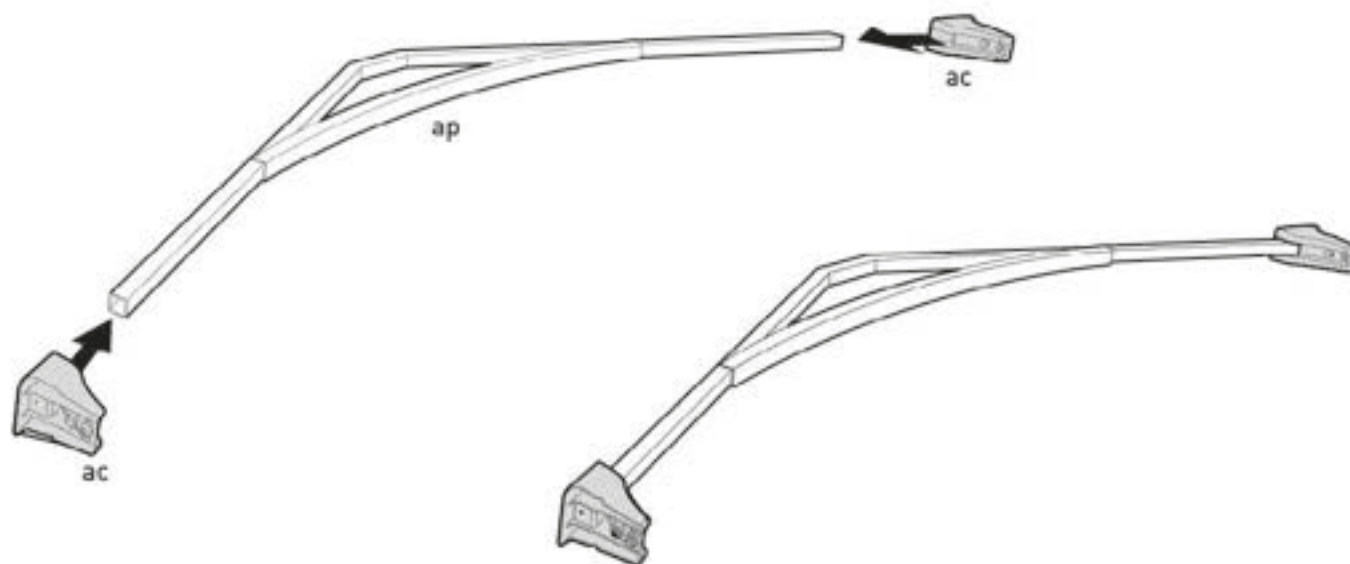

40

Self drill screw  
**s23b** (x4)  
 0.98"  
 25 mm



Roof Support Assembly  
 Montage du support de toit  
 Pieza de Soporte del Tejado  
 Montage der Dachstützung  
 Montlage Daksteun  
 Assemblaggio del Supporto del Tetto  
 Montagem do Suporte do Telhado



- Rotate the roof support into the proper orientation
- Tourner le support de toit dans le bon sens
- Haga girar el soporte del tejado
- Drehen sie die dachstützung in die richtige ausrichtung
- Draai de dakondersteuning in de juiste positie
- Ruotare il supporto del tetto nel suo corretto orientamento
- Gire o suporte do telhado na orientação correta

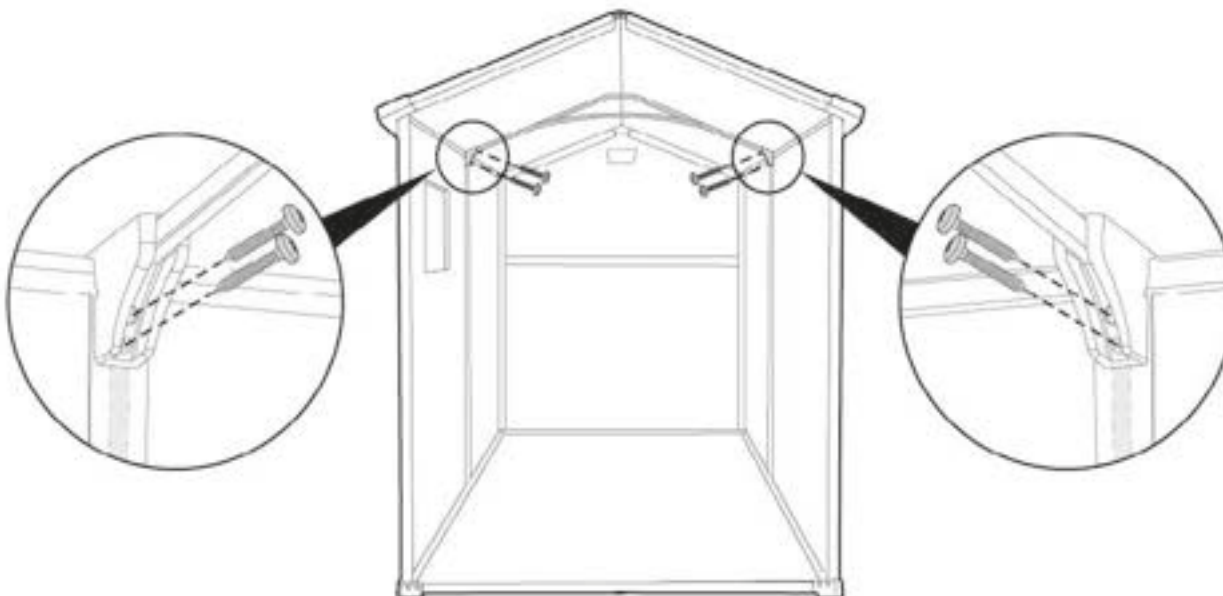
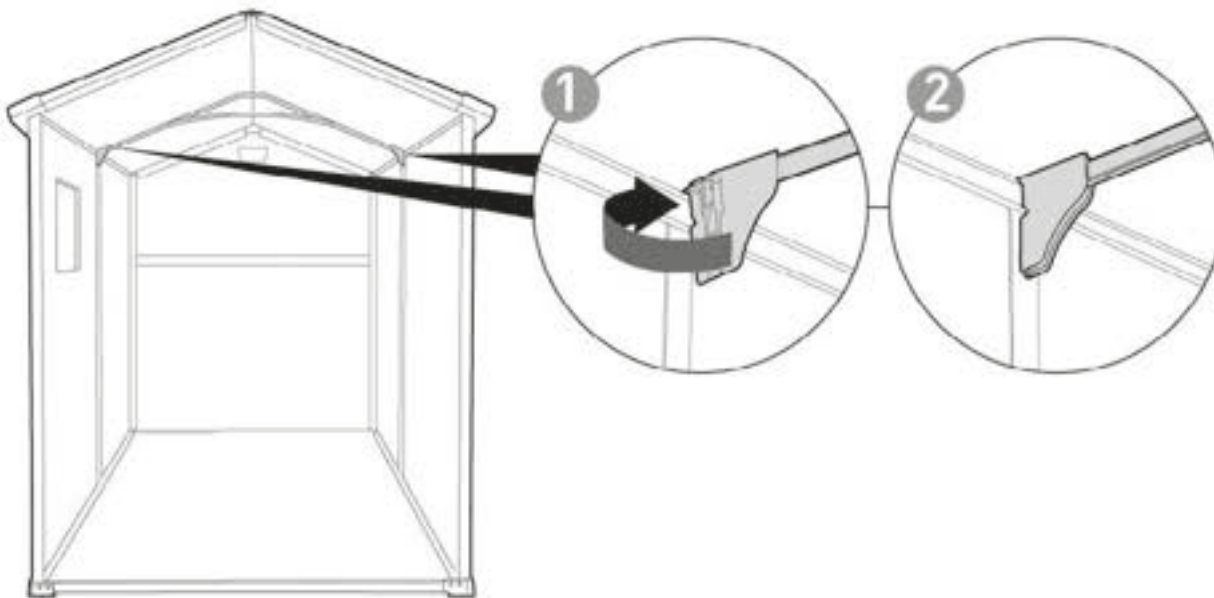

- 41** | **sh** (x1)  | **s26b** (x4)  
1"  
26 mm 

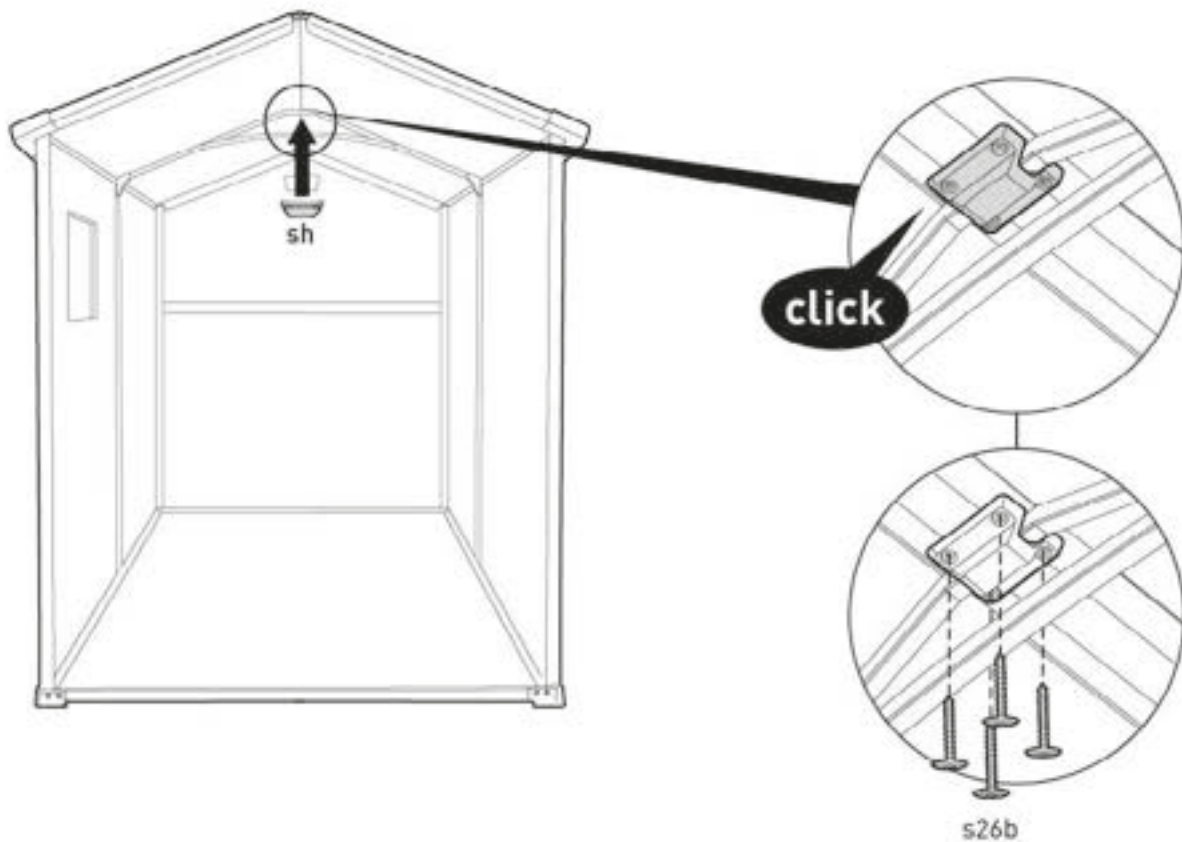

- 42** | **s26b** (x16)  
1"  
26 mm 

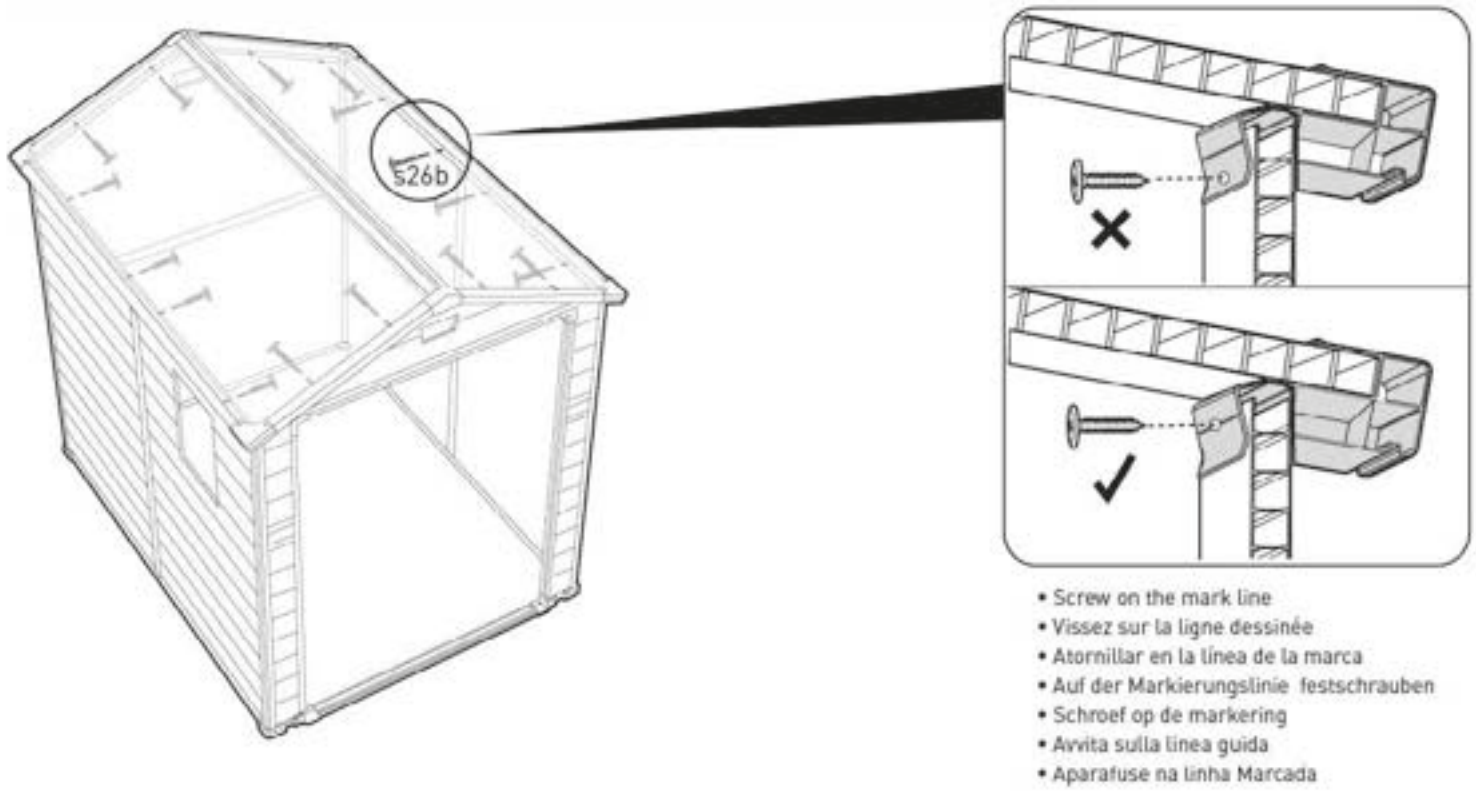

DOOR ASSEMBLY | MONTAGE DE LA PORTE | ARMADO DE LA PUERTA | MONTAGE DER TÜR | DEURMONTAGE | MONTAGGIO DELLA PORTA | MONTAGEM DA PORTA

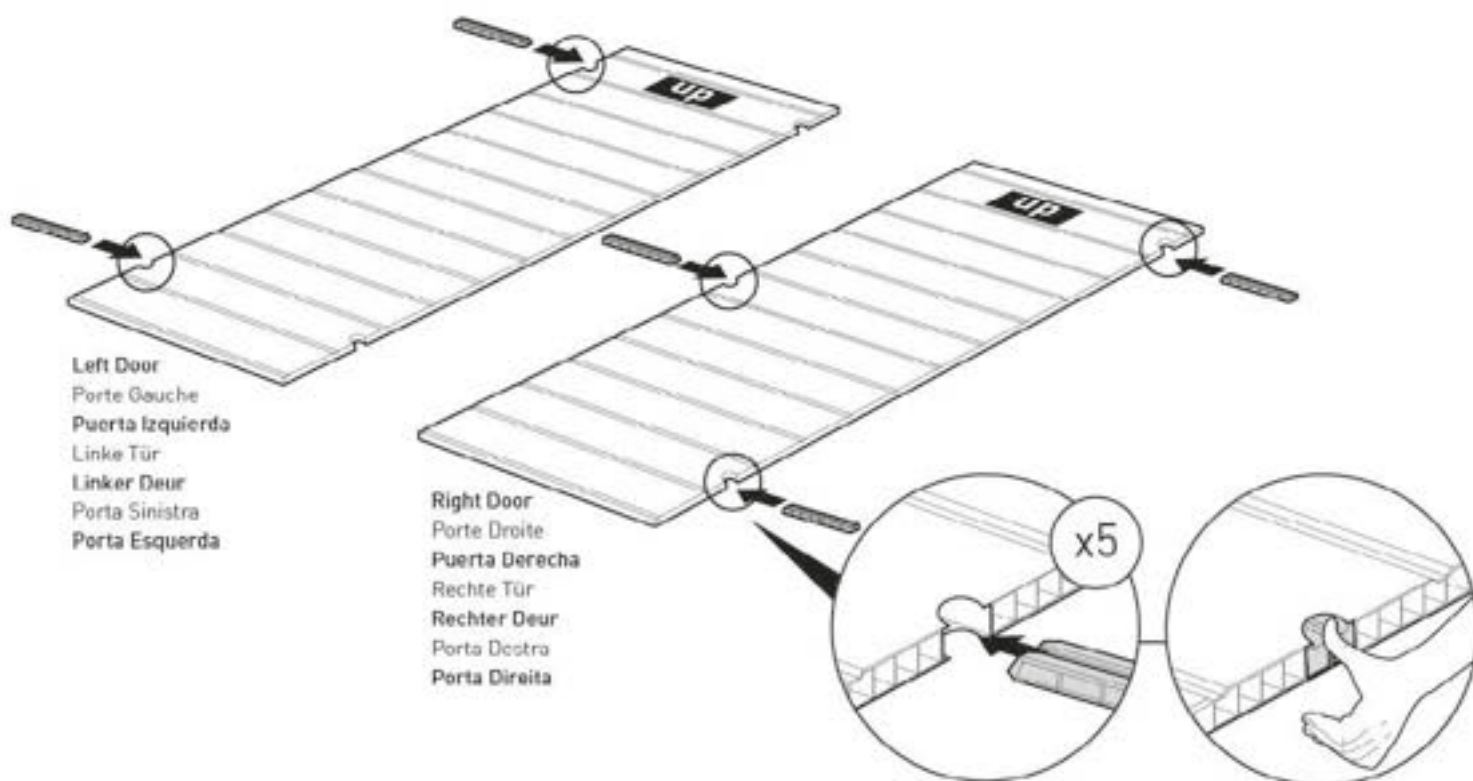
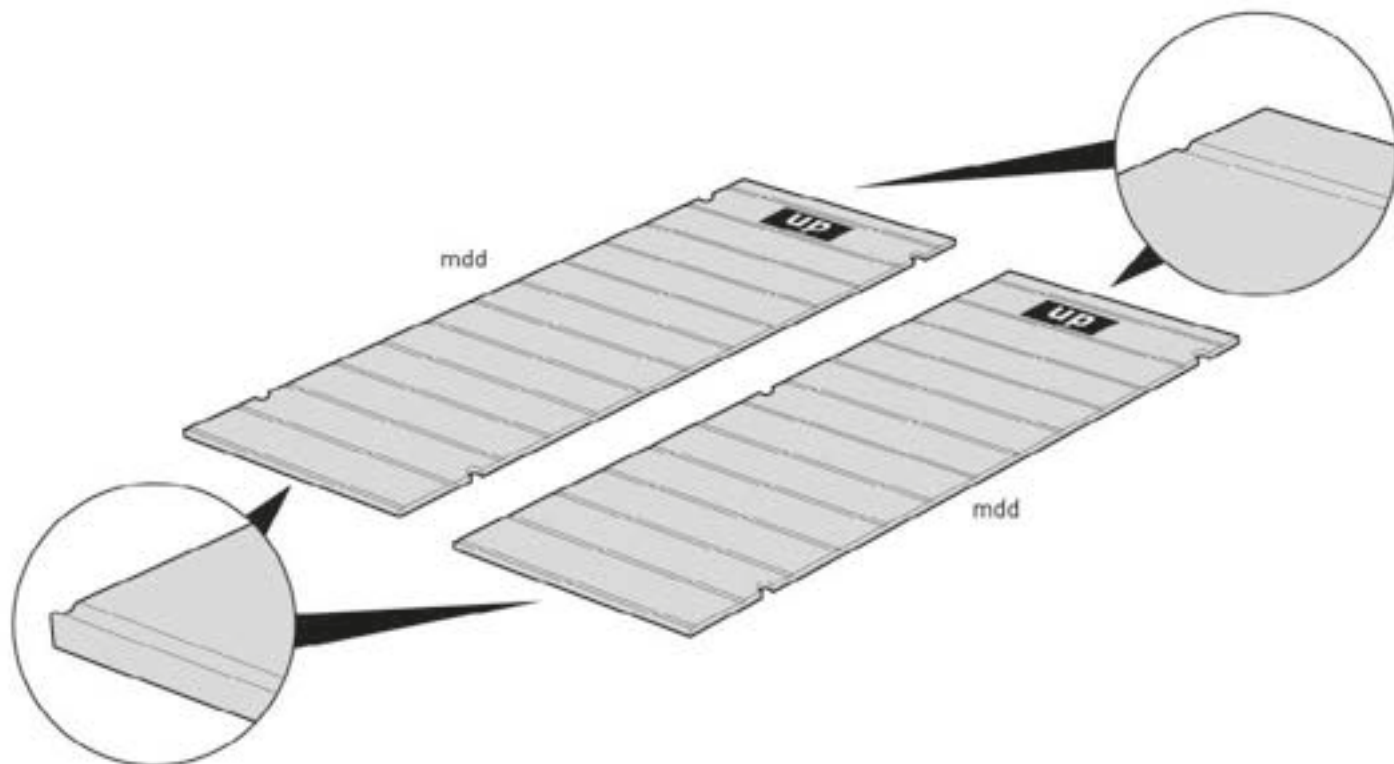
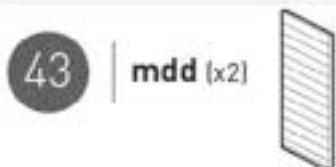

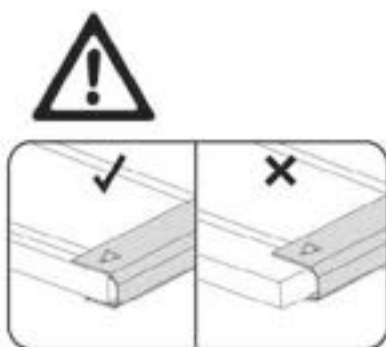
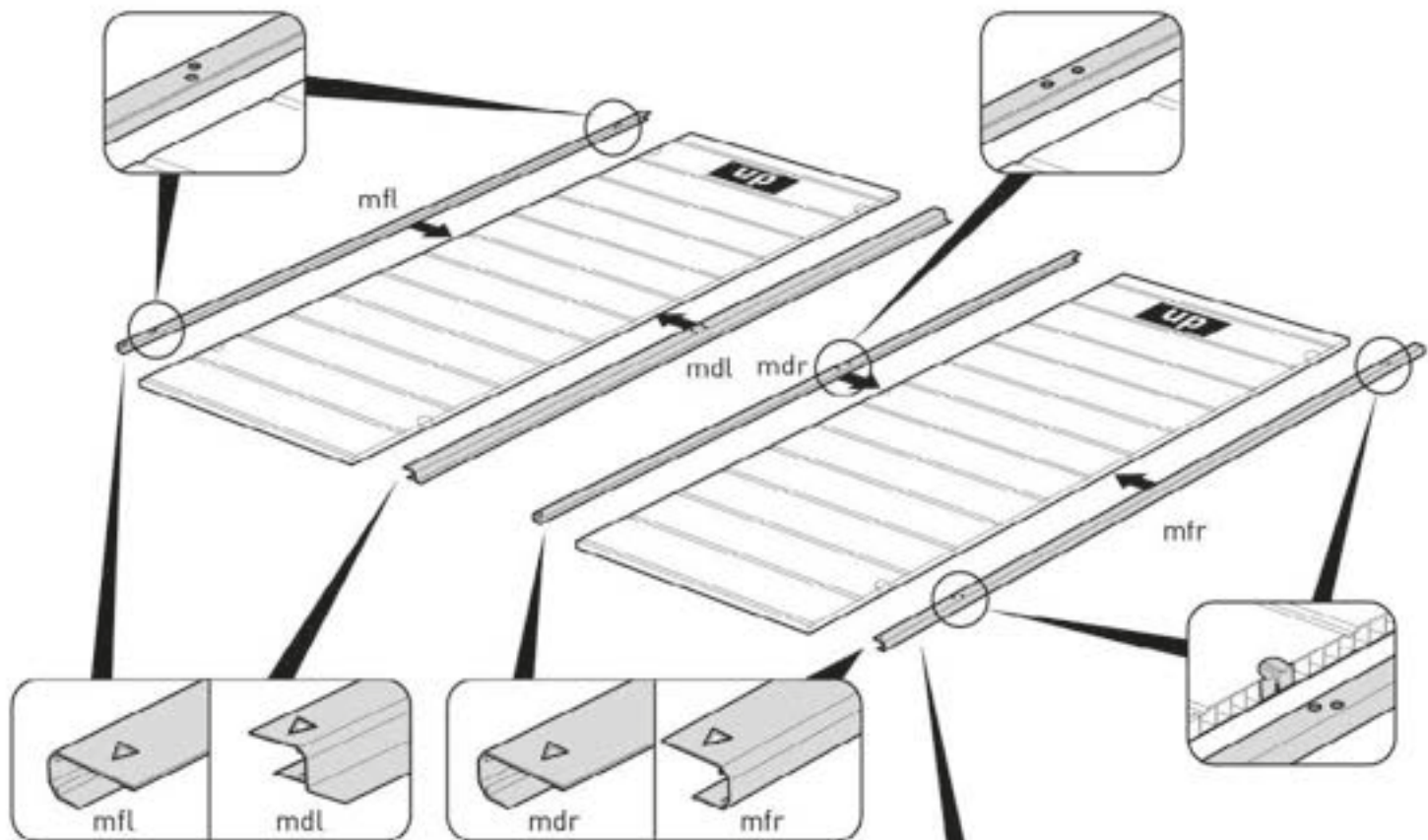

- Align edge of aluminium profile with edge of door panel
- Aligner le bord du profil en aluminium avec le bord du panneau de porte
- Alinea el bordo del perfil de aluminio con el borde del panel de la puerta
- Die Kante des Aluminiumprofils an der Kante des Türblattes ausrichten
- Breng de rand van het aluminium profiel op één lijn met de rand van het deurpaneel
- Allineare il bordo del profilo di alluminio con il bordo del pannello della porta
- Alinhar a borda do perfil de alumínio com a borda do painel da porta

**46** | **ldd** (x2)  | **rdd** (x2) 

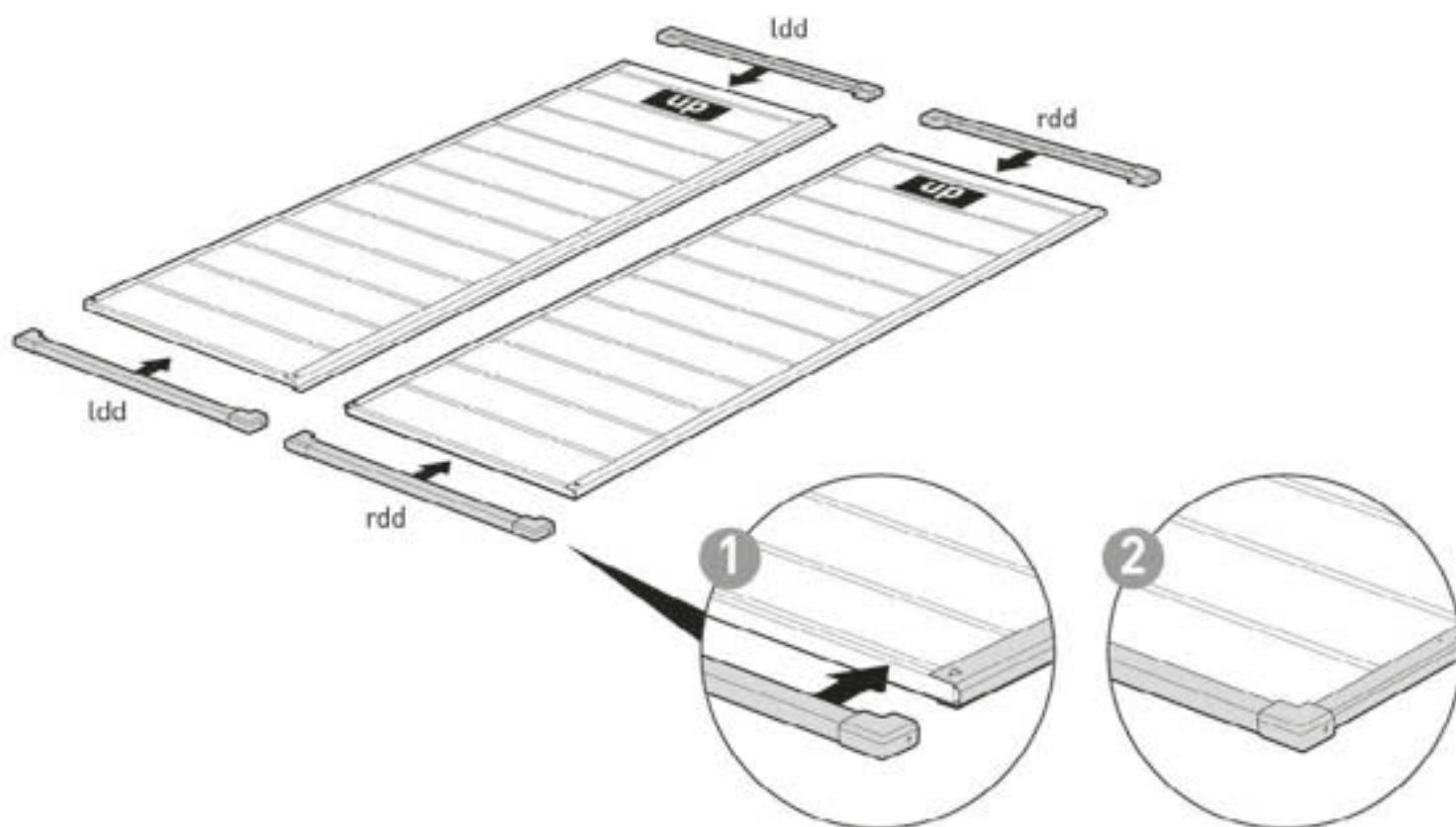

**47** |

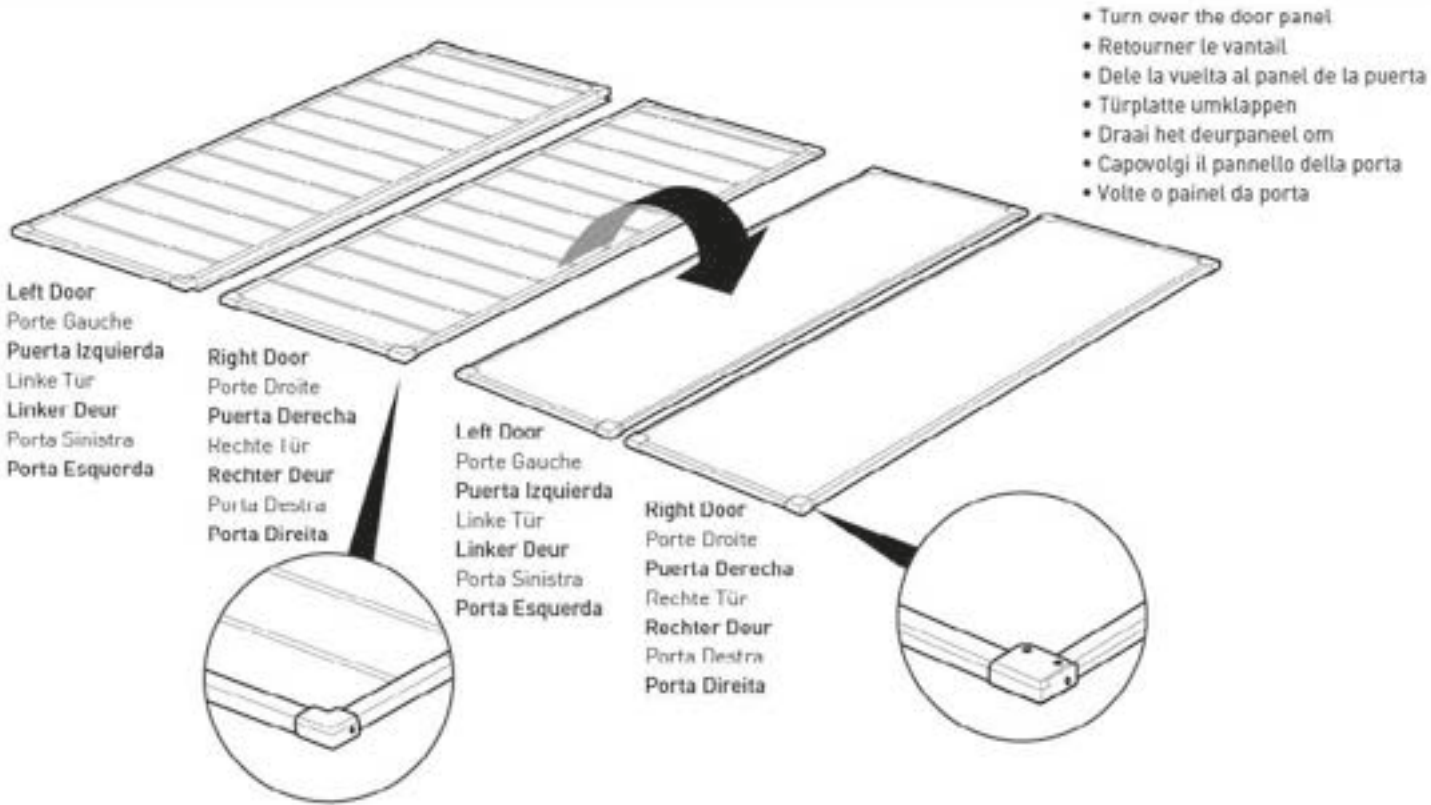

- Turn over the door panel
- Retourner le vantail
- Dale la vuelta al panel de la puerta
- Türplatte umklappen
- Draai het deurpaneel om
- Capovolgì il pannello della porta
- Volte o painel da porta

Left Door  
Porte Gauche  
Puerta Izquierda  
Linke Tür  
Linker Deur  
Porta Sinistra  
Porta Esquerda

Right Door  
Porte Droite  
Puerta Derecha  
Rechte Tür  
Rechter Deur  
Porta Destra  
Porta Direita

Left Door  
Porte Gauche  
Puerta Izquierda  
Linke Tür  
Linker Deur  
Porta Sinistra  
Porta Esquerda

Right Door  
Porte Droite  
Puerta Derecha  
Rechte Tür  
Rechter Deur  
Porta Destra  
Porta Direita

48

Self drill screw

**ds2b** (x8)

0.39"

10 mm



Left Door  
Porte Gauche  
Puerta Izquierda  
Linke Tür  
Linker Deur  
Porta Sinistra  
Porta Esquerda

Right Door  
Porte Droite  
Puerta Derecha  
Rechte Tür  
Rechter Deur  
Porta Destra  
Porta Direita

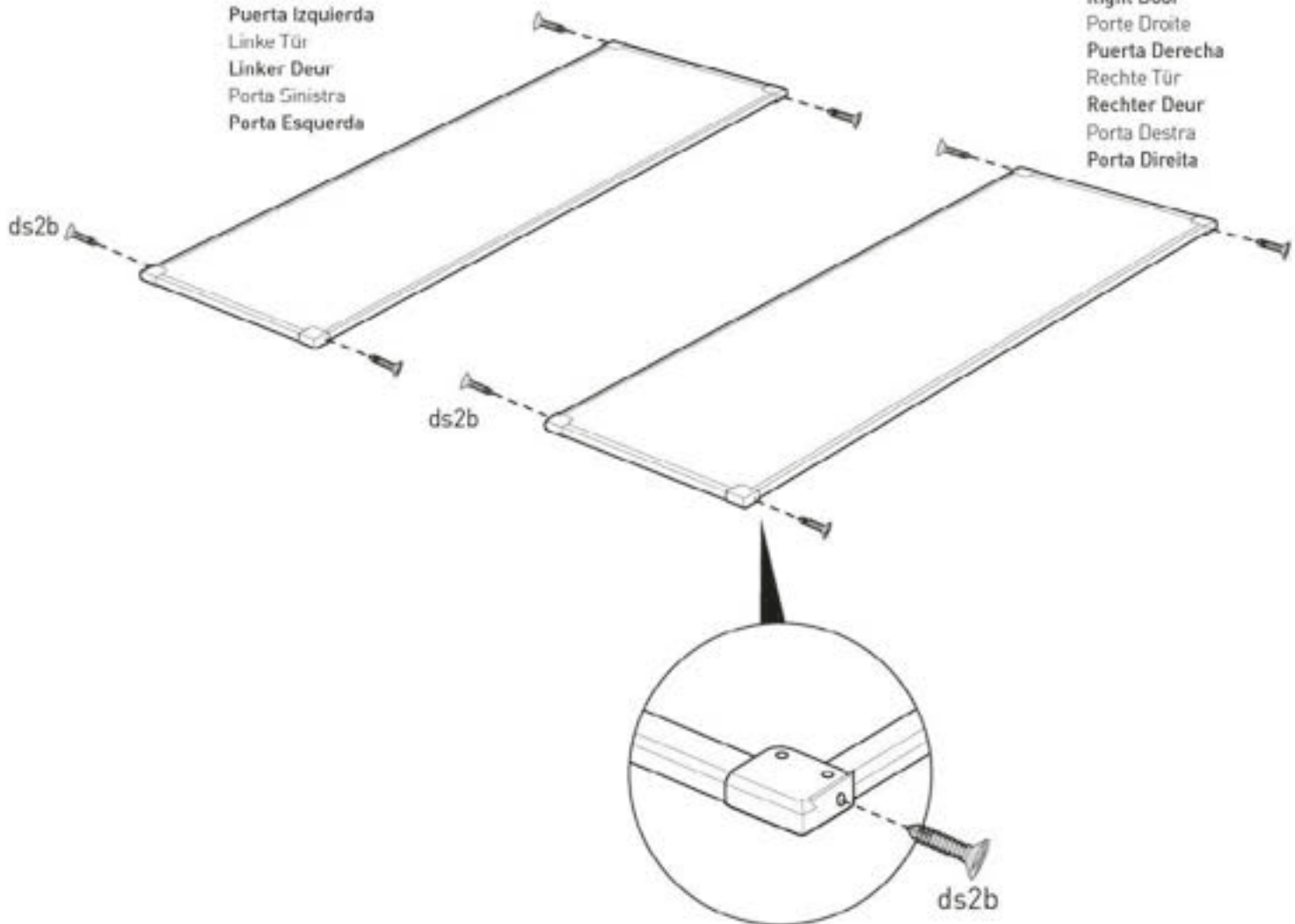



49

Self drill screw  
**s10b** (x20)  
 0.47"  
 12 mm



**mpn** (x2)



**mtl** (x1)



**mbi** (x1)

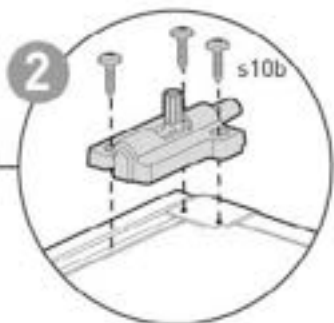
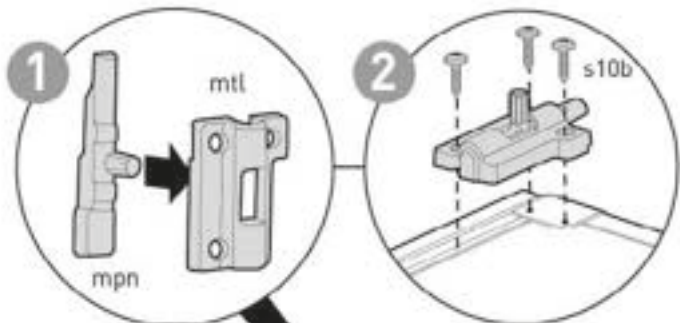

Left Door  
 Porte Gauche  
 Puerta Izquierda  
 Linke Tür  
 Linker Deur  
 Porta Sinistra  
 Porta Esquerda

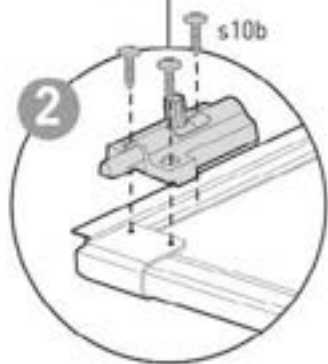
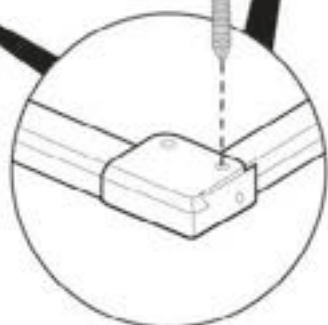
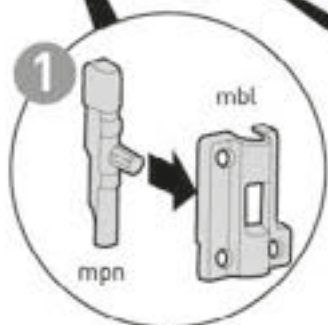

Right Door  
 Porte Droite  
 Puerta Derecha  
 Rechte Tür  
 Rechter Deur  
 Porta Destra  
 Porta Direita

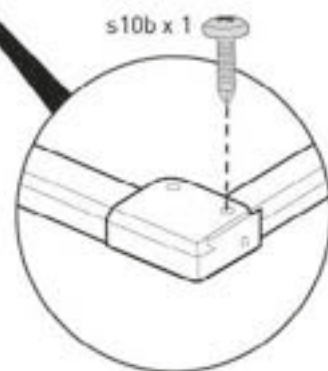
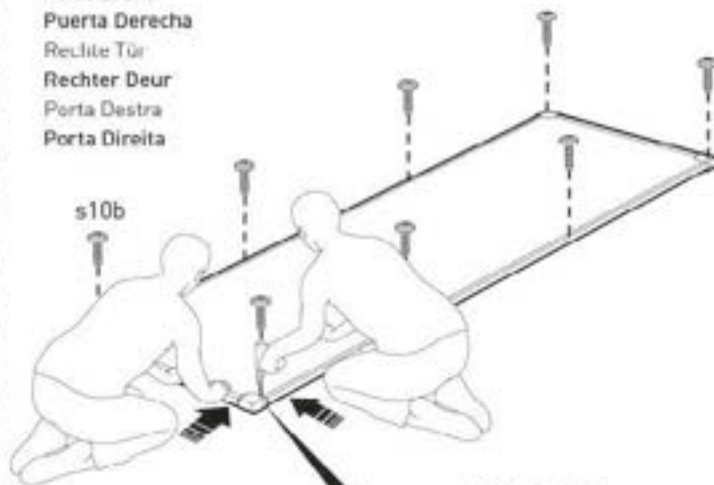

50

dh (x4)



s13b (x28)  
0.47"  
12 mm

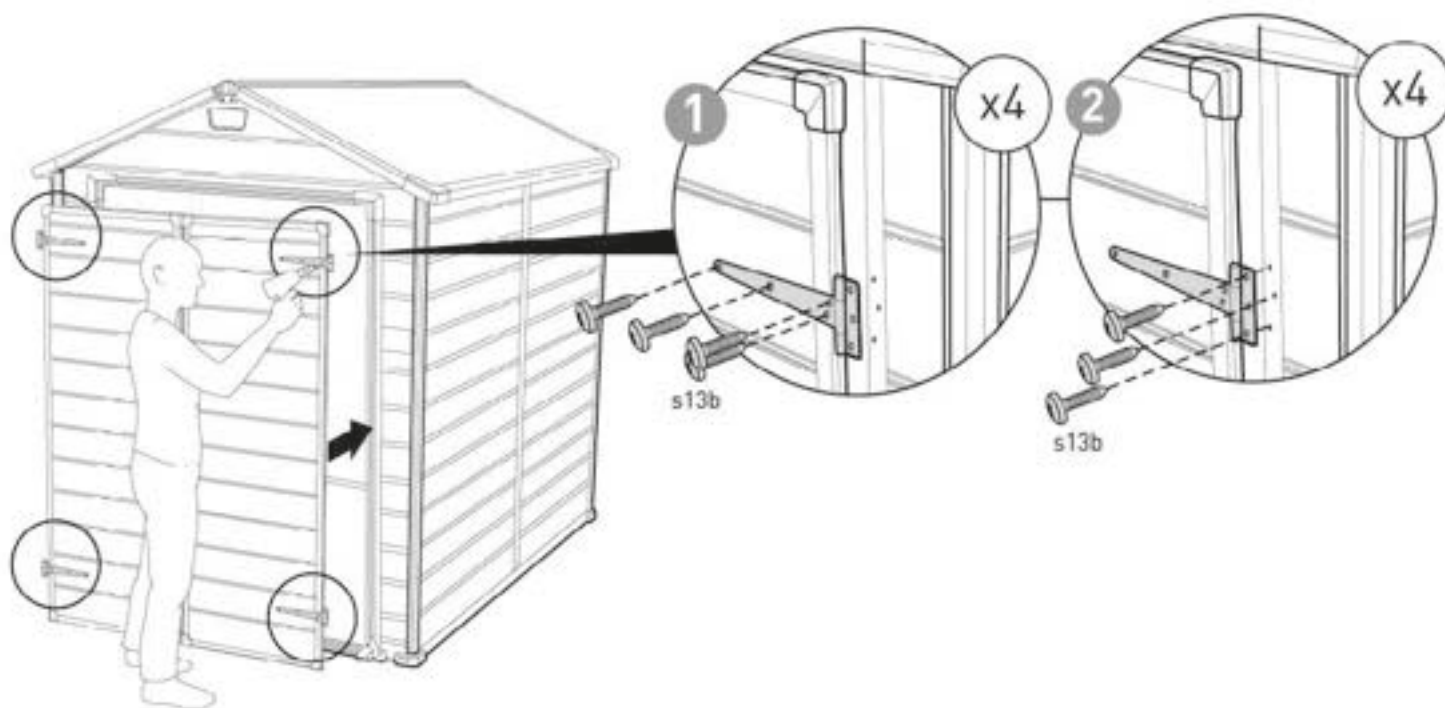

**51** | **smdl** (x1)  | **smdp** (x1) 

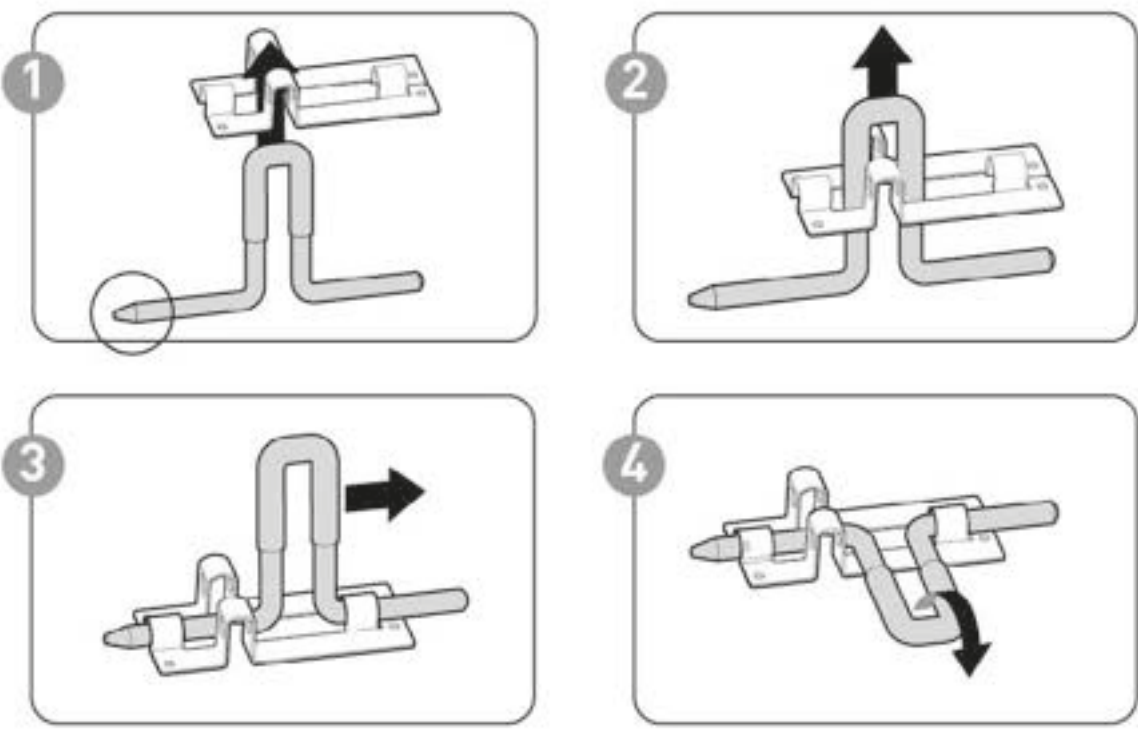

**52** | **smdl + smdp** (x1)  | **smdb** (x1)  | **s13b** (x8) 0.47" 12 mm 

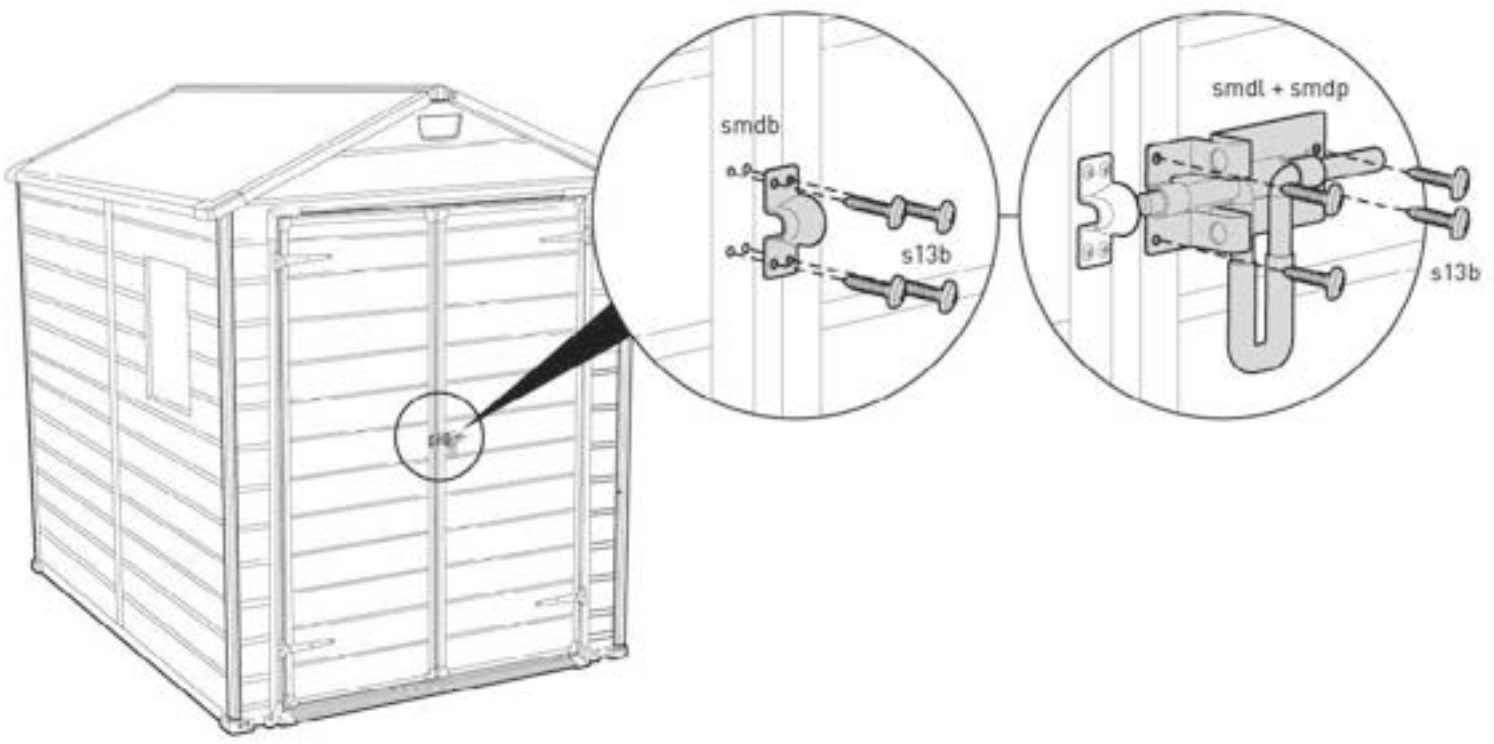

53

V (x2)

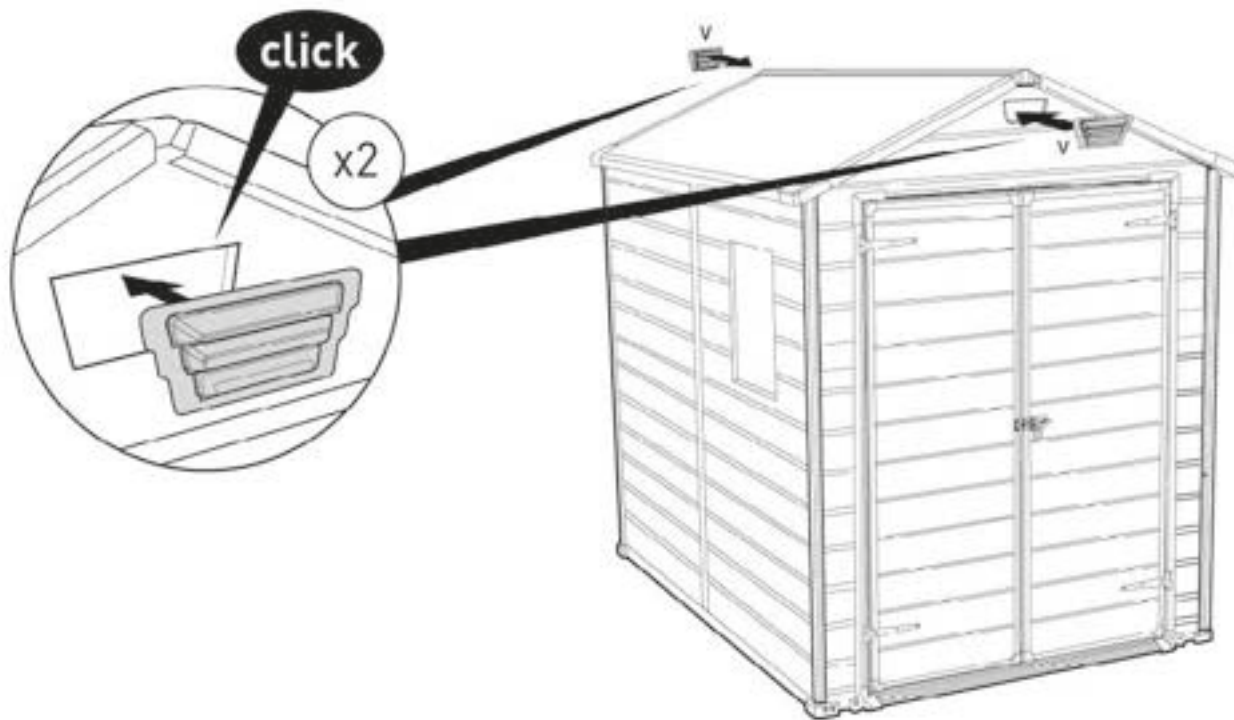

54

kc (x2)



s26b (x4)  
1"  
26 mm

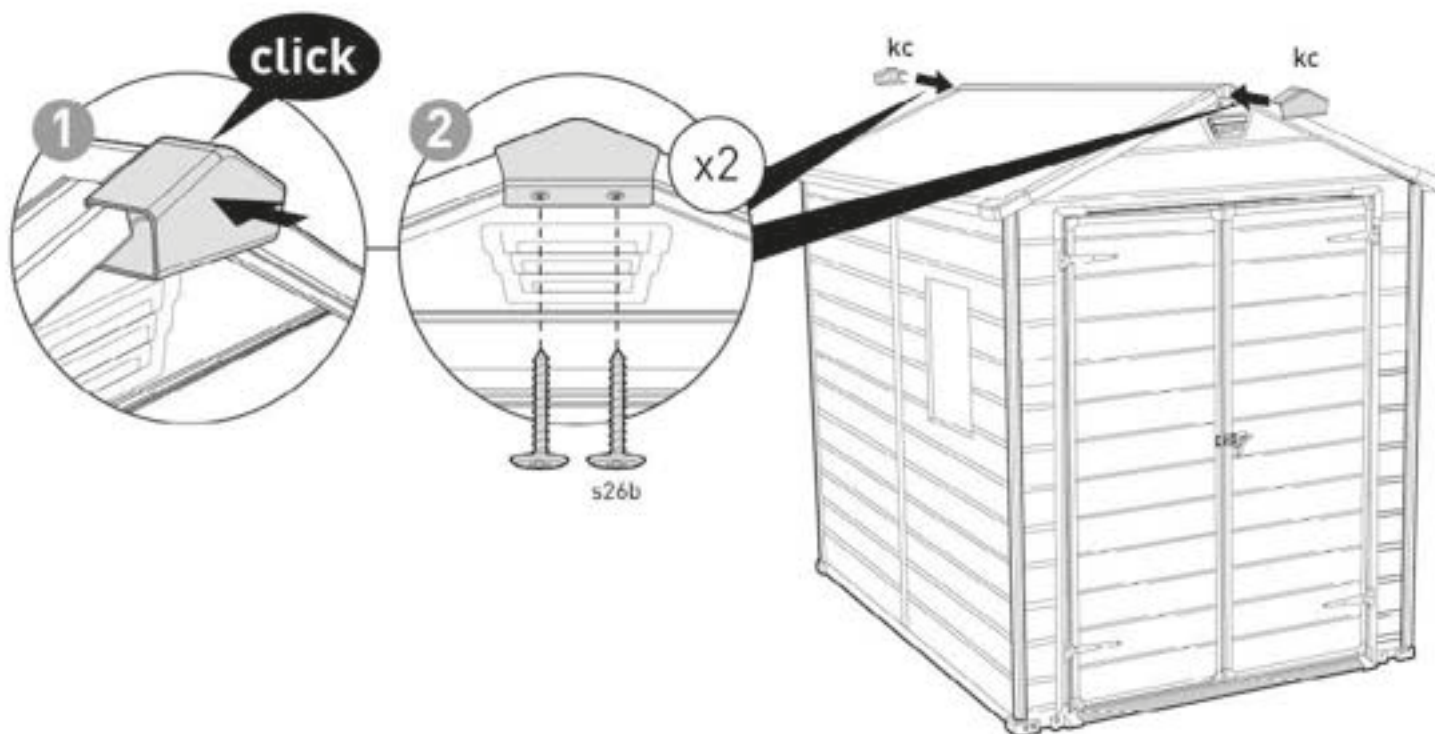

WINDOW ASSEMBLY | MONTAGE DE LA FENÊTRE | VENTANA DEL TECHO | FENSTERHMONTAGE | RAAMMONTAGE | MONTAGGIO DE LA FINESTRA | MONTAGEM DO JANELA

55

f-out (x1)



pls (x1)

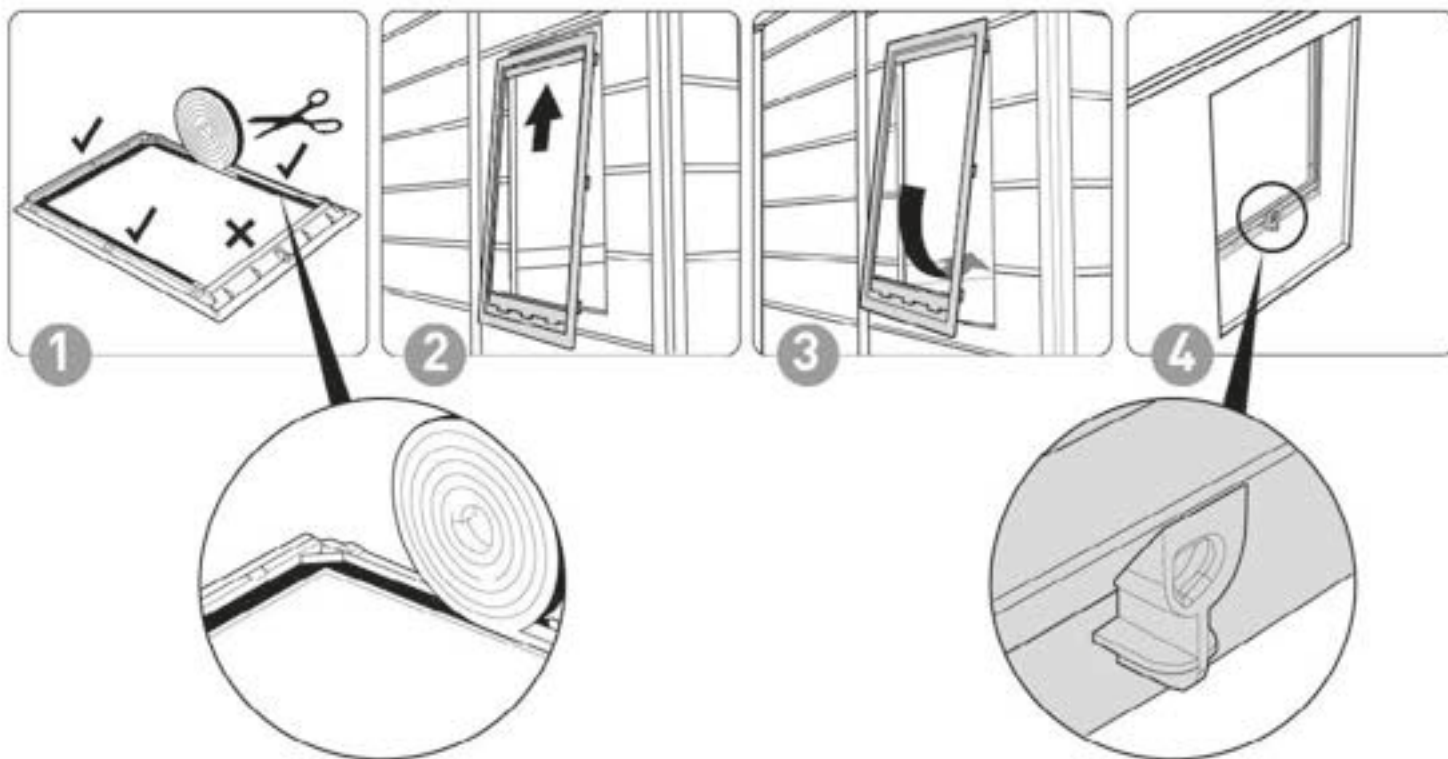

56

acw (x1)

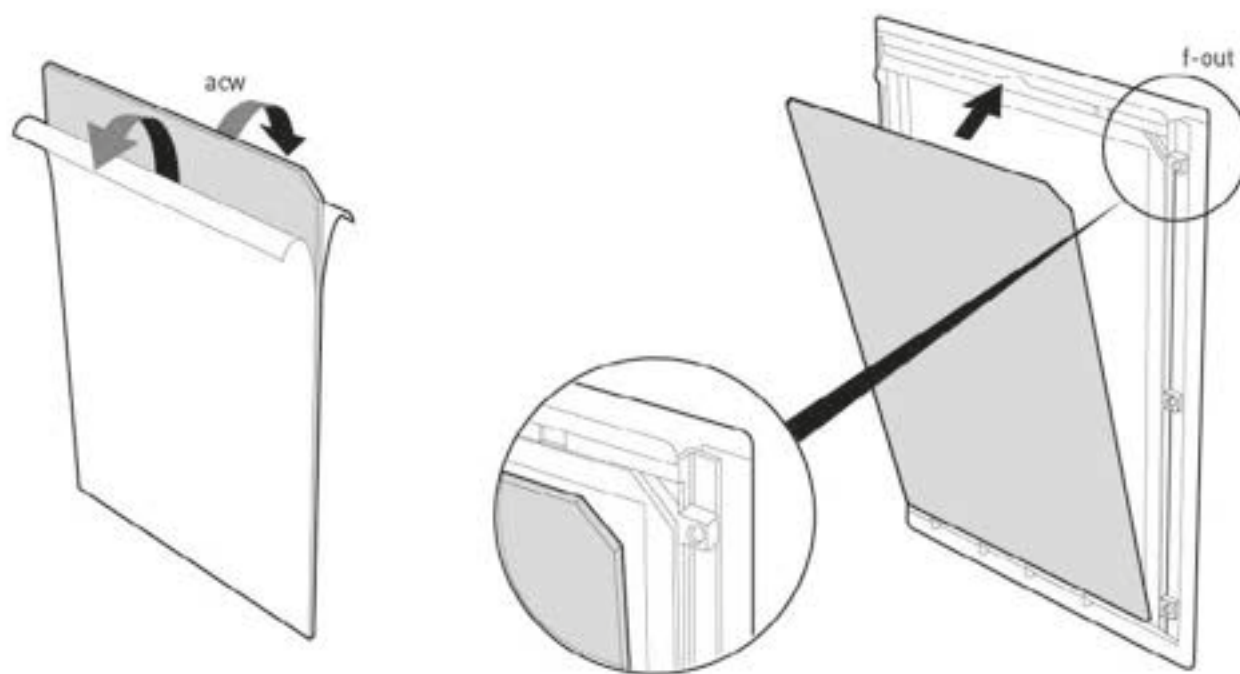

57

f-in (x1)



sc15 (x7)  
0.63"  
16 mm

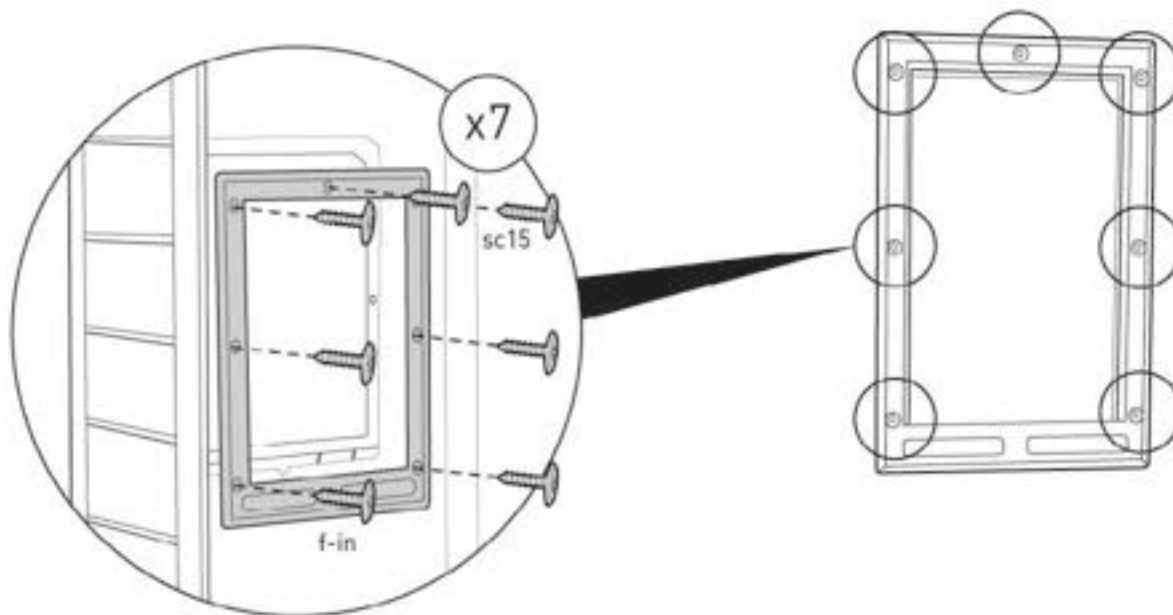

## OPTION | OPCIÓN | OPTIE | OPZION | OPÇÃOE

### SECURING THE SHED TO A FOUNDATION

Affix the shed to the foundation by drilling holes in the shed floor at the pre-marked locations and screwing it into the foundation using appropriate screws (screws not included).

### FIXER L'ABRI SUR UNE FONDATION

Fixez l'abri à la fondation en perçant des trous dans le sol aux endroits pré-marqués et en insérant des vis adéquates dans la fondation (vis non fournies).

### ASEGURAR EL COBERTIZO A UN CIMIENTO

Fije el cobertizo a los cimientos perforando agujeros en el suelo del cobertizo en los lugares previamente marcados y atorníllelo a los cimientos utilizando los tornillos adecuados (los tornillos no están incluidos).

### ABSICHERN DES SCHUPPENS AN EIN FUNDAMENT

Bringen Sie den Schuppen auf dem Fundament an, indem Sie an den Markierungen Löcher in den Schuppenboden bohren und diesen mit passenden Schrauben auf dem Fundament festschrauben (Schrauben nicht enthalten).

### HET SCHUURTJE OP HET FUNDAMENT VASTZETTEN

Bevestig het schuurtje aan de fundering door op de aangegeven plaatsen gaten te boren in de vloer van het schuurtje en het schuurtje aan de fundering te schroeven met behulp van passende schroeven (schroeven niet inbegrepen).

### ASSICURARE LA COPERTURA ALLE FONDAMENTA

Fissa il deposito attrezzi alle fondamenta facendo dei fori nel pavimento nelle posizioni pre-segnalate ed avvitandolo alle fondamenta utilizzando apposite viti (viti non incluse).

### FIXAR O ABRIGO NUMA FUNDAÇÃO

Afixe o abrigo à base abrindo buracos no chão nos locais previamente assinalados e aparafusando-o à mesma utilizando parafusos adequados (os parafusos não estão incluídos).

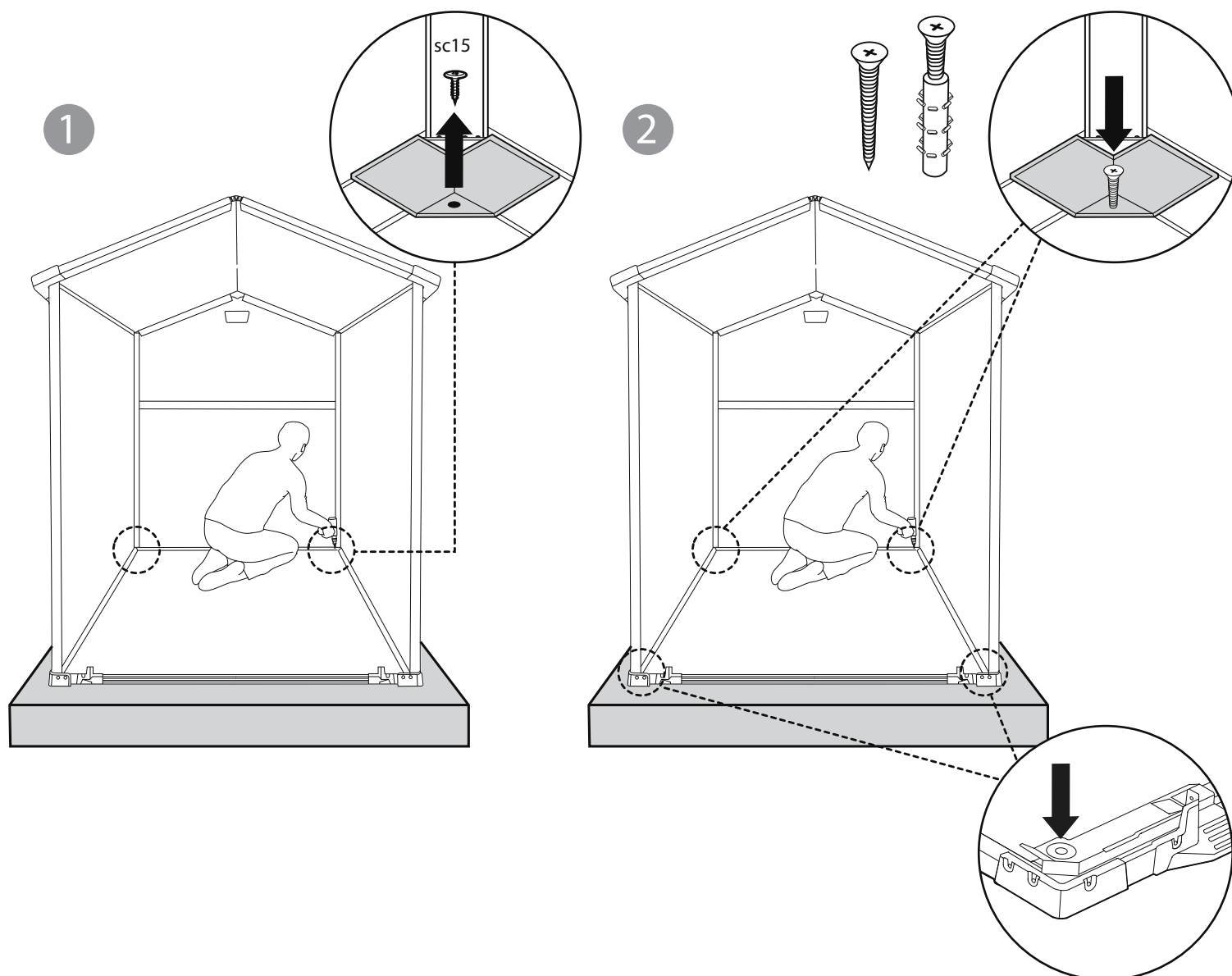

## CARE AND SAFETY GUIDELINES

- The shed is intended for storage purposes only. It is not designed for habitation.
- It is strongly recommended to secure the shed to an immovable object or anchor to the ground by drilling holes in the shed floor (at the pre-marked locations) and inserting proper screws into the ground (screws are not included).
- Do not attempt assembly on windy or cold days.
- Periodically check the shed to ensure that it is stable and that the site is level.
- Be careful when handling parts with steel edges.
- When assembling or handling the shed, use only those tools listed in the user manual.
- Always wear work gloves, safety goggles and long sleeves when assembling or performing any maintenance on your shed.
- Avoid using a lawnmower or mechanical scythe near the shed.
- Wear safety goggles and always follow the manufacturer's instructions when using power tools.
- Wash the shed with a garden hose or a mild detergent solution. Do not use a stiff brush or abrasive cleaners, including degreasers and oil- or acetone-based cleaning materials, as these may stain or damage the shed.
- Do not store hot items, such as recently used grills and blowtorches, and volatile chemicals in the shed.
- Avoid placing heavy items against the walls, as this may cause distortion.
- Keep the roof clear of accumulated snow and leaves. Large amounts of snow on the roof can damage the shed, making it unsafe to enter.
- Wind direction is an important factor to consider when determining the location of the shed. Reduce exposure to the wind, in general, and of the door side in particular. Keep doors closed and locked when the shed is not in use to prevent wind damage.
- Do not stand on the roof.
- Consult your local authorities to check if permits are required to erect the shed.

## INSTRUCTIONS DE SÉCURITÉ ET D'ENTRETIEN

- L'abri a été conçu uniquement à des fins de stockage. Il n'a pas été conçu à des fins d'habitation.
- Il est fortement recommandé de sécuriser l'abri à un objet inamovible ou de le fixer au sol en creusant des trous dans le sol de l'abri (aux emplacements marqués) et d'insérer les vis adaptées dans le sol (vis non incluses).
- N'essayez pas de réaliser le montage par jour venteux ou froid.
- Vérifiez de temps en temps la tenue de l'abri afin de garantir sa stabilité et la mise à niveau du site, sur lequel il est posé.
- Manipulez les pièces présentant des bords en acier avec précaution.
- Lors de l'assemblage ou de la manipulation de l'abri, utilisez seulement les outils listés dans le mode d'emploi.
- Portez toujours des gants de travail, des lunettes de protection et des vêtements à manches longues lors de l'assemblage ou de l'accomplissement d'activités de maintenance sur votre abri.
- Évitez d'utiliser une tondeuse à gazon ou une faux mécanique à proximité de l'abri.
- Portez des lunettes de sécurité et suivez toujours les instructions du fabricant lors de l'utilisation d'outils électriques.
- Lavez l'abri à l'aide d'un tuyau d'arrosage de jardin ou d'un détergent non abrasif. N'utilisez pas une brosse dure ou de nettoyeurs abrasifs, y compris les dégraissants et les solutions de nettoyage à base d'acétone ou d'huile, car ils peuvent tacher ou endommager l'abri.
- Ne stockez pas d'objets chauds, tels qu'un grill ou un chalumeau récemment utilisé, ou des produits chimiques volatiles dans l'abri.
- Évitez de placer des objets lourds contre les murs de votre abri, cela peut entraîner une déformation.
- Entretenez le toit pour éviter l'accumulation de neige ou de feuilles. Une grande quantité de neige sur le toit peut endommager l'abri, rendant périlleux l'accès à l'intérieur.
- La direction du vent est un facteur important à prendre en compte lors du choix de la localisation de l'abri. Réduisez l'exposition au vent, en général, et surtout pour le côté de la porte. Maintenez les portes fermées et verrouillées lorsque l'abri n'est pas utilisé, afin d'éviter tout dégât dû au vent.
- Ne montez pas sur le toit.
- Consultez les autorités de votre localité pour vérifier la nécessité de disposer d'un permis pour ériger l'abri.

## ADVERTENCIA SOBRE EL CUIDADO Y LA SEGURIDAD

- La cobertizo está diseñada solo para el almacenamiento de productos. No está diseñada para habitar en ella.
- Se recomienda encarecidamente fijar la cobertizo a un objeto inamovible o anclarla al suelo taladrando agujeros en el suelo de la cobertizo (en los lugares premarcadas para ello), e insertando tornillos adecuados en el suelo (los tornillos no están incluidos).
- No intente montarlo en días de viento o cuando haga frío.
- Compruebe la cobertizo periódicamente para asegurarse de que es estable y de que el lugar es uniforme.
- Tenga cuidado al manejar las partes con bordes de acero.
- Al montar o manipular la cobertizo, use solamente las herramientas enumeradas en el manual del usuario.
- Use siempre guantes de trabajo, anteojos protectores y mangas largas para armar el cobertizo o realizar cualquier tarea de mantenimiento en el mismo.
- Evite usar un cortacésped o un cortacésped cerca de la cobertizo.
- Lleve gafas de seguridad y siga siempre las instrucciones del fabricante al utilizar herramientas eléctricas.
- Lave la cobertizo con una manguera de jardín o con un detergente suave. No utilice un cepillo rígido ni limpiadores abrasivos, incluyendo desengrasantes y materiales de limpieza basados en petróleo o acetona, ya que todos ellos pueden manchar o dañar la cobertizo.
- No guarde objetos calientes, como sopletes usados recientemente, ni elementos químicos volátiles.
- Evite situar objetos pesados contra las paredes, ya que esto puede causar deformación.
- Mantenga el techo limpio de nieve y hojas acumuladas. Una gran cantidad de nieve en el tejado puede dañar el cobertizo, haciendo que sea inseguro entrar.
- La dirección del viento es un factor importante a tener en cuenta al determinar la ubicación del cobertizo. Reduzca la exposición al viento en general y al lateral de la puerta en particular. Mantenga las puertas cerradas y bloqueadas cuando no utilice el cobertizo para evitar daños del viento.
- Ne montez pas sur le toit.
- Consultez avec vos autorités locales et si nécessaire, ne marchez pas sur le toit. Permis pour lever le cobertizo.

## PFLEGE - UND SICHERHEITSHINWEISE

- Der Gartenschuppen dient einzig und allein der Lagerung von Gegenständen. Der Schuppen ist nicht für Wohnzwecke ausgelegt.
- Es wird dringend empfohlen, den Schuppen an einem unbeweglichen Gegenstand zu befestigen oder Mithilfe von Löchern im Schuppenboden im Boden zu verankern (die Bohrungen müssen an den vormarkierten Stellen erfolgen), wobei geeignete Schrauben zu verwenden sind (Schrauben sind nicht im Lieferumfang enthalten).
- Führen Sie den Aufbau nicht an windigen oder kalten Tagen durch.
- Überprüfen Sie den Schuppen regelmäßig auf Stabilität und stellen Sie sicher, dass der Standort eben ist.
- Seien Sie vorsichtig, wenn Sie mit Teilen hantieren, die Stahlkanten aufweisen.
- Für Aufbau und Handhabung des Schuppens verwenden Sie bitte nur Werkzeuge, die in der Aufbauanleitung aufgelistet sind.
- Tragen Sie bei der Montage des Gartenschuppens oder Wartungsarbeiten stets Arbeitshandschuhe, eine Schutzbrille und Kleidungsstücke mit langen Ärmeln.
- Vermeiden Sie den Einsatz von Rasenmäher und maschineller Sense im direkten Umfeld des Schuppens.



- Tragen Sie eine Schutzbrille und befolgen Sie bei Verwendung von Elektrowerkzeugen immer die Anweisungen des Herstellers.
- Reinigen Sie den Schuppen mit einem Gartenschlauch und einem milden Reinigungsmittel. Verwenden Sie auf keinen Fall eine harte Bürste und Scheuer- oder Entfettungsmittel sowie Öl- oder Acetonhaltige Reinigungsmittel, da diese Flecken verursachen oder den Schuppen beschädigen könnten.
- Lagern Sie keine heißen Gegenstände im Schuppen, wie etwa kürzlich benutzte Grills oder Lötlampen und auch keine flüchtigen Chemikalien.
- Lehnen Sie keine schweren Gegenstände an die Wände des Schuppens, da sich dadurch der gesamte Schuppen verziehen könnte.
- Halten Sie das Dach frei von Schnee und angesammeltem Blattwerk. Große Mengen an Schnee können den Schuppen beschädigen und beim Betreten gefährlich werden.
- Die Windrichtung ist ein wichtiger Faktor, der bei der Aufstellung des Schuppens unbedingt berücksichtigt werden muss.  
Vermeiden Sie zu hohe Windbelastungen, insbesondere einen hohen Winddruck auf die Türen. Halten Sie die Türen immer geschlossen und verriegelt, wenn der Schuppen nicht genutzt wird, um eine Beschädigung durch Windbelastungen zu vermeiden.
- Betreten Sie auf keinen Fall das Dach des Schuppens.
- Wenden Sie sich bitte an Ihre lokale Behörde und erkundigen Sie sich dort, ob zum Aufbau des Schuppens eine Genehmigung erforderlich ist.

#### RICHTLIJNEN VOOR ZORG EN VEILIGHEID

- Het tuinhuisje is uitsluitend bedoeld voor opslag. Het is niet ontworpen voor bewoning.
- Het wordt sterk aanbevolen om het tuinhuisje vast te maken aan een immobiel object of in de grond te verankeren door het boren van gaten in de vloer (op de gemarkeerde plaatsen) en het met de geschikte schroeven in de grond te bevestigen (schroeven zijn niet inbegrepen).
- Probeer niet op stormachtige of koude dagen te monteren.
- Controleer het tuinhuisje regelmatig dat het stabiel en waterpas staat.
- Wees voorzichtig als u werkt met onderdelen met staalranden.
- Gebruik bij de montage of het hanteren van het tuinhuisje alleen de gereedschappen die in de handleiding vermeldt staan.
- Draag altijd werkhandschoenen, oogbescherming en lange mouwen als u uw schuurtje monteert of onderhoud
- Vermijd het gebruik van een grasmaaier of mechanische zeis in de buurt van het tuinhuisje.
- Draag een veiligheidsbril en volg altijd de instructies van de fabrikant als u elektrisch gereedschap gebruikt.
- Was het schuurtje met een tuinslang of een zacht schoonmaakmiddel. Gebruik geen harde borstel of schuurmiddelen, met inbegrip van ontvetters en schoonmaakmiddelen op basis van olie of aceton, omdat die het tuinhuisje kunnen beschadigen of vlekken achterlaten.
- Zet geen hete voorwerpen, zoals een pas gebruikte grill of branders in de schuur, en bewaar er ook geen vluchtige stoffen.
- Plaats geen zware voorwerpen tegen de wanden, die daardoor misvormd kunnen raken.
- Houd het dak vrij van opgehoopte sneeuw en bladeren. Grotere hoeveelheden sneeuw op het dak kunnen het schuurtje beschadigen, waardoor het betreden gevaarlijk kan zijn.
- De windrichting is een belangrijke factor bij het bepalen van de locatie van het tuinhuisje. Verminder blootstelling aan de wind, in het algemeen, en bijzonder aan de deurzijde. Houd de deuren gesloten en vergrendeld wanneer het tuinhuisje niet in gebruik is om windschade te voorkomen.
- Ga niet op het dak staan.
- Raadpleeg uw plaatselijke autoriteiten om te controleren of een vergunning vereist is voor het plaatsen van het tuinhuisje.

#### LINEE GUIDA PER LA CURA E LA SICUREZZA

- Il prodotto va utilizzato solo per scopi di immagazzinamento. Non è progettato per abitarvi.
- Si raccomanda vivamente di fissare il prodotto su un piano inamovibile o ancorandolo al suolo tramite i fori nel pavimento (nelle posizioni pre-segnalate) ed inserendo viti adeguate nel terreno (le viti non sono incluse).
- Non tentare il montaggio in giornate ventose o fredde.
- Controllate periodicamente il prodotto per accertarvi che sia stabile e che sia a livello del terreno.
- Fai attenzione quando maneggi parti con bordi in acciaio.
- Durante il montaggio o la manipolazione del prodotto, utilizzate solo gli strumenti elencati nel manuale utente.
- Indossare sempre guanti da lavoro, protezioni per gli occhi e maniche lunghe durante il montaggio o durante la manutenzione
- Evitate di utilizzare un tosaerba o una falce meccanica nei pressi del prodotto stesso.
- Indossate occhiali di sicurezza e seguite sempre le istruzioni del produttore quando utilizzate utensili elettrici.
- Lavate il prodotto con un tubo da giardino o una soluzione detergente delicata. Non utilizzate una spazzola dura o detersivi abrasivi, né sgrassanti e materiali di pulizia per l'olio - o a base di acetone, in quanto questi possono macchiarlo o danneggiarlo.
- Non conservate oggetti caldi, come grill e lampade per saldature né sostanze chimiche evaporabili all'interno del prodotto.
- Evitate di posizionare oggetti pesanti contro le pareti, in quanto ciò potrebbe causare una deformazione del prodotto.
- Mantenete il tetto pulito dalla neve e dalle foglie accumulate. Grandi quantità di neve sul tetto possono danneggiare il prodotto, rendendone precaria la struttura.
- La direzione del vento è un fattore importante da considerare quando scegliete la posizione del prodotto. Riducete l'esposizione al vento, in generale, in particolare della porta laterale. Tenete le porte chiuse e bloccate quando il prodotto non è in uso per prevenire i danni del vento.
- Non salite sul tetto.
- Consultate le autorità locali per verificare se sono necessari dei permessi per assemblare il prodotto.

#### DIRETRIZES SOBRE CUIDADOS E SEGURANÇA

- O abrigo destina-se apenas a fins de armazenamento. Não foi projetado para habitação.
- Recomenda-se vivamente a fixação do abrigo a um objeto imóvel ou fixá-lo no chão fazendo furos no piso do abrigo (nos locais previamente marcados) e a inserção de parafusos adequados no chão (os parafusos não estão incluídos).
- Não tente fazer a montagem em dias ventosos ou frios.
- Verifique periodicamente o abrigo para garantir que está estável e que o sítio está nivelado.
- Tenha cuidado ao manusear peças com pontas em aço.
- Ao montar ou manipular o abrigo, utilize apenas as ferramentas indicadas no manual do utilizador.
- Utilize sempre luvas e óculos de protecção, assim como vestuário comprido ao montar ou efectuar qualquer procedimento de manutenção no seu abrigo.
- Evite a utilização de um cortador de relva ou foice mecânica perto do abrigo.
- Use óculos de segurança e siga sempre as instruções do fabricante ao utilizar ferramentas elétricas.
- Lave o abrigo com uma mangueira de jardim ou uma solução de detergente suave. Não use uma escova rija ou detergentes abrasivos incluindo desengordurantes ou materiais de limpeza com base de óleo ou acetona, visto que estes podem manchar ou danificar o abrigo.
- Não guarde artigos quentes, como grelhas e maçaricos recentemente utilizados, e químicos voláteis no abrigo.
- Evite a colocação de artigos pesados contra as paredes, visto que isto pode causar distorção.
- Mantenha o telhado livre de acumulação de neve e folhas. Grandes quantidades de neve no telhado podem danificar o abrigo, tornando-o inseguro para entrar.
- A direção do vento é um fator importante a ter em consideração ao determinar a localização do abrigo. Reduza a exposição ao vento, em geral, e em particular da porta lateral. Mantenha as portas fechadas e trancadas quando o abrigo não estiver a ser utilizado para evitar danos causados pelo vento.
- Não fique no telhado.
- Consulte as autoridades locais para saber se são necessárias licenças para erguer o abrigo.