

ASSEMBLY INSTRUCTION

PLEASE READ this document before assembly to familiarise yourself with the different stages of construction



Carefully check the contents of this box against the parts list below

Notes:

- The assembly will require 2 people
- Do not tighten all the bolts until the sofa is fully assembled

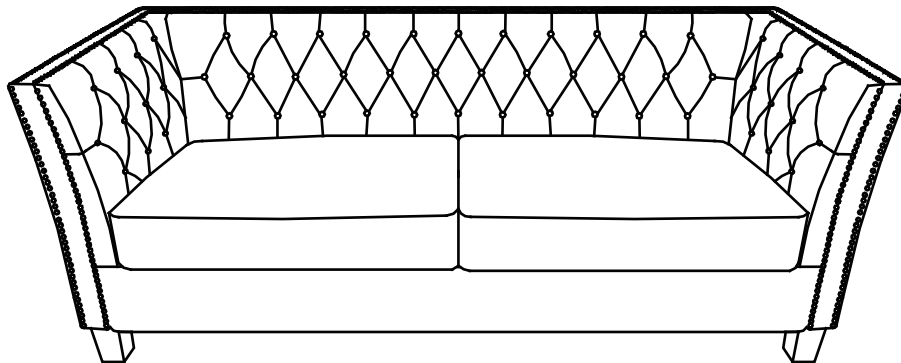
3 SEATER

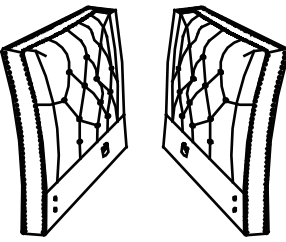
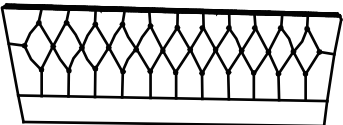
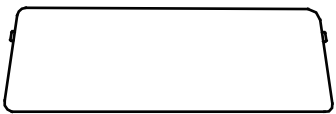
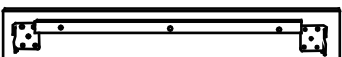
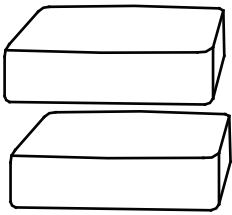
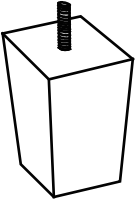
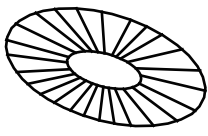

 <p>A: Armrest x 2</p>	 <p>B: Backrest x1</p>	 <p>C: Seat Base x1</p>	 <p>D: Footboard x1</p>
 <p>E: Seat Cushions x 2</p>	 <p>F: Legs x 4</p>	 <p>G: Spacer x 4</p>	 <p>H: Middle Leg x1</p>
 <p>I: Allen Key x 1</p>			

①

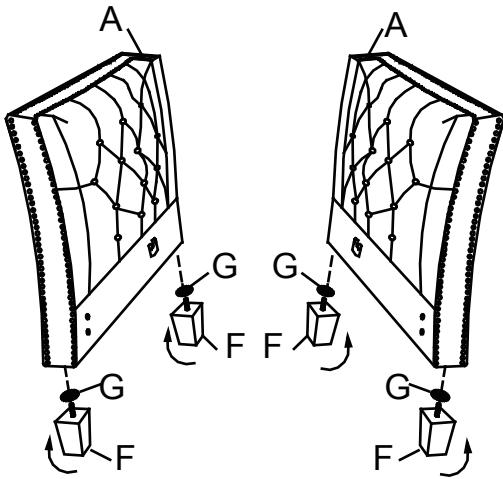

Parts required
 A: Armrest x 2
 F: Legs x 4
 G: Spacer x 4

Place a Spacer through the bolt on the Leg and screw in a clockwise direction on the bottom of the Armrest. Repeat this process on all 4 Legs.

②

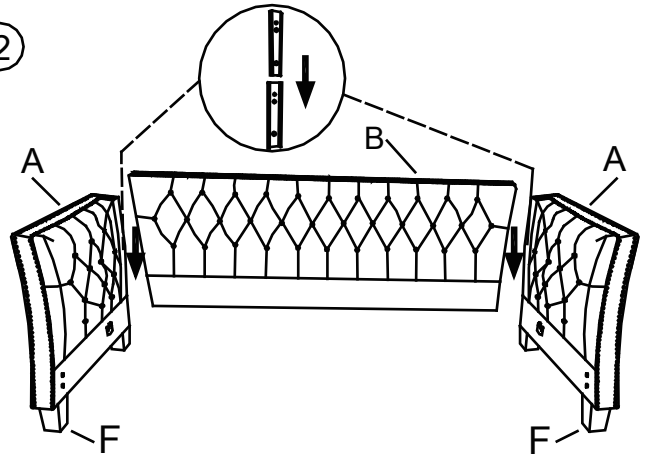

Additional Parts Required
 B: Backrest x 1

Position the Backrest and both Armrests as shown in diagram. Locate the metal sliders on the back of the Armrest and the sides of the Backrest. Lift the backrest and align the metal sliders, slowly lower both sides of Backrest until all the tops are level.

③

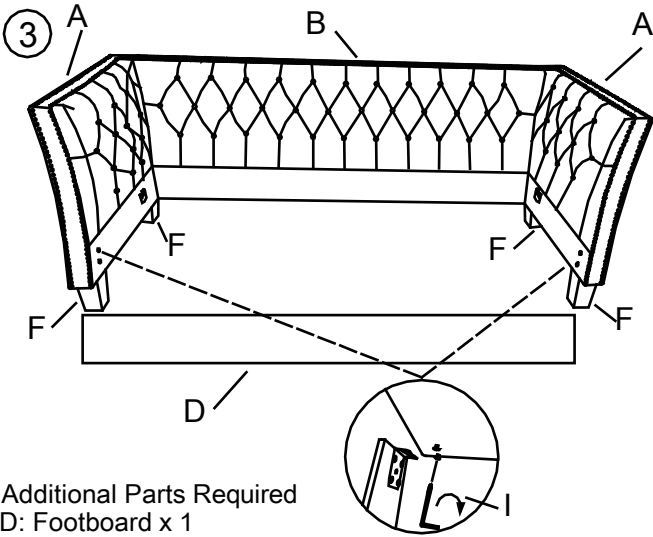

Additional Parts Required
 D: Footboard x 1
 I: Allen Key x 1

Using the Allen Key loosen bolts to make it easier to position the Footboard in place. Tighten bolts using Allen Key

④

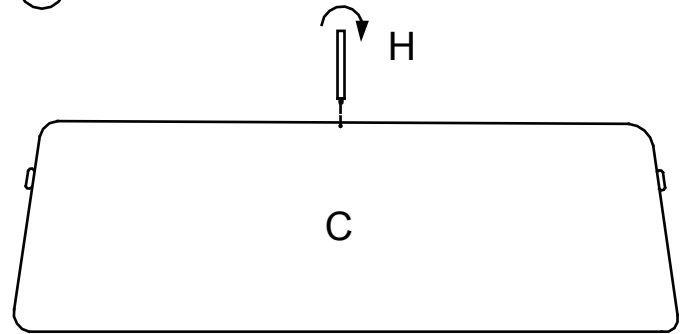

Parts Required

H: Middle Leg x 1

Clockwise from the specified position

⑤

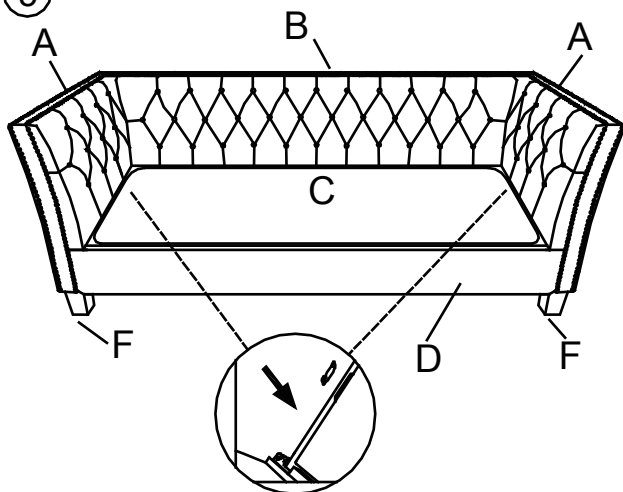

Additional Parts Required

C: Seat Base x 1

Locate the metal clips on the Seat Base and lower into position as illustrated above.

⑥

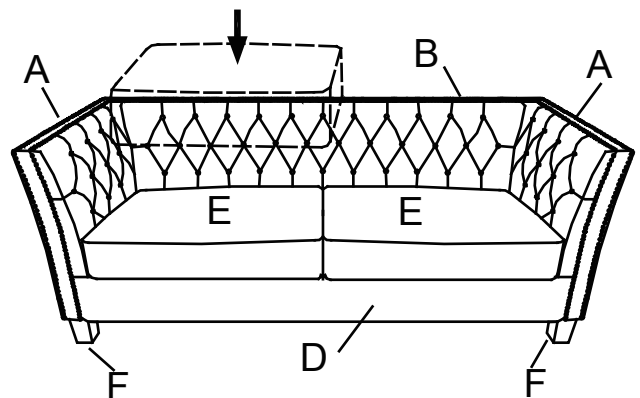

Additional Parts Required

E: Seat Cushions x 2

Place both Seat Cushions in place as illustrated above.