

Assembly Instructions

Victory Orangerie™ - Garden Chalet

Approx. Dim.

305Lx364Wx269Hcm / 120.1"Lx143.7"Wx105.9"H

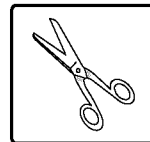
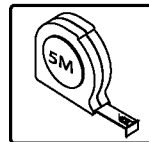
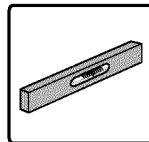
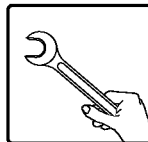
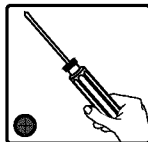
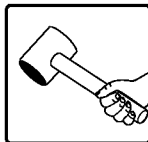
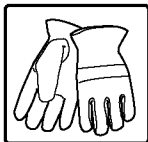

After Sale Service

Email: customer.service@palram.com

USA 877-627-8476
Canada 1 800-866-5749

England 01302-380775
Germany 0180-522-8778

France 0169-791-094
International +972 4-848-6942

www.palramapplications.com

IMPORTANT

Please read these instructions carefully before you start to assemble this greenhouse. Keep these instructions in a safe place for future reference.

 When encountering the information icon, please refer to the relevant assembly step for additional comments and assistance.

 This icon indicates that the installer should be inside the product.

» Customer Service

For assistance with assembly or for replacement parts – please log onto our website or call our service line (number is on the title page).

Additional information can be found at our website: www.palramapplications.com

» Safety Advice

- It is of utmost importance to assemble all of the parts according to the directions. Do not skip any step.
- We strongly recommend using work gloves during assembly.
- Always wear shoes and safety goggles when working with extruded aluminium.
- If using a step ladder or power tools ensure that you follow the manufacturer's safety advice.
- Do not touch overhead power cables with the aluminium profiles.
- Do not attempt to assemble the greenhouse in windy or wet conditions.
- Dispose of all plastic bags safely keep them out of reach of small children.
- Keep children away from the assembly area.
- Do not lean against or push the greenhouse during construction.
- Do not position your greenhouse in an area exposed to excessive wind.
- Do not attempt to assemble this greenhouse if you are tired, have taken drugs or alcohol or if you are prone to dizzy spell.
- Hot items such as recently used grills, blowtorches etc. must not be stored in the greenhouse. Ensure there are no hidden pipes or cables in the ground before inserting the pegs.
- This product is designed to use as greenhouse only.

» Care & Maintenance

When your greenhouse needs to be cleaned, use a mild detergent solution and rinse with cold clean water. DO NOT use acetone, abrasive cleaners or other special detergents to clean the clear panels. It is recommended to check periodically that roof panels caps (plastic part 329 & profile 981) are set in place.

» Tools & Equipment

T001 - Special tool for Screws 411 and nuts 412

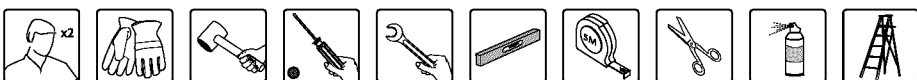
**» Before Assembly**

This is a multi-part assembly best achieved by two people. Allow at least half a day for assembly process.

Selecting a site - the greenhouse must be, positioned and fixed on a flat level surface.

Choose a sunny position away from overhanging trees.

We are strongly recommend to fix your greenhouse directly to a solid concrete foundation. When doing that use the pre drilled holes in the metal base supplied.

Take out all components parts of the packages. Sort the parts and check against the contents parts list.

During assembly parts should be laid out close at hand. Keep all small parts (screws etc.) in a bowl so they do not get lost.

» During Assembly

Carry out the assembly steps in the order set out in the instructions.

You may use Silicon lubricant spray in order to help you slide the profiles on the connectors.

Do not spray the Polycarbonate



panels. Use the rubber mallet if necessary.

Step 3: Part 7063 is the greenhouse threshold.

Fixing it determines the front side of the greenhouse.

Step 10: Make sure the base is square by measuring the diagonals and level by using a spirit level.

Firmly connect the greenhouse to a level final position immediately after completion of the assembly.

Steps 15: Part 7180 is used for assembly assistance.

Steps 29: Remove Part 7180 and discard.

Steps 50+51: Please repeat steps 47-49 and work according to the parts id mentioned in this manual.

Step 70 : In case the window is not closed properly, please release the screws, adjust the profile and tighten the screw.

Tighten all screws when completing assembly.

- Screws 411 and nuts 412 are used throughout the assembly process.
- Screws 411 are to be assembled from the outside and nuts 412 from the inside of the greenhouse.
- If not specified otherwise, do not fasten screws and nuts (411 & 412) more than 2-3 turns only. Do not tighten them until completion of the panels' assembly. These 2 icons indicate if screws' tightening is required or not.
- However, in some steps, temporary tightening of a few screws may be needed to prevent a profile from falling till it will be fully connected in the next steps.

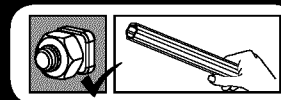
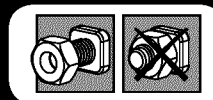

412



411



WICHTIG

Bitte lesen Sie diese Anweisungen sorgfältig durch, bevor Sie mit dem Aufbau des Gewächshauses beginnen.

Heben Sie diese Anweisungen an einem sicheren Ort auf, um später auf sie zurückgreifen zu können.



Beim Aufbau wird Ihnen das Informationssymbol begegnen. Für zusätzliche Kommentare und Unterstützung beziehen Sie sich bitte auf die entsprechende Aufbaustufe.



Dieses Symbol zeigt an, dass der Installer sollte im Inneren des Produkts.

» Kundendienst

Für Hilfe bei dem Aufbau oder für Ersatzteile – können Sie sich entweder auf unserer Webseite einloggen oder unseren Kundendienst anrufen (die Nummer steht auf der Titelseite).

Weitere Informationen finden Sie auf unserer Webseite: www.palramapplications.com

» Sicherheitshinweise

- Es ist von grösster Wichtigkeit, alle Teile genau gemäss den Anweisungen zusammenzubauen. Lassen Sie keinen Schritt aus.
- Wir empfehlen wärmstens, während des Aufbaus Arbeitshandschuhe zu tragen.
- Tragen Sie immer Schuhe und eine Schutzbrille, wenn Sie mit stranggepresstem Aluminium arbeiten.
- Wenn Sie eine Stufenleiter oder Elektrowerkzeuge benutzen, achten Sie darauf, die Sicherheitshinweise des Herstellers zu befolgen.
- Berühren Sie mit den Aluminiumprofilen keine Oberleitungen.
- Versuchen Sie nicht, das Gewächshaus bei windigem oder regnerischem Wetter zusammenzubauen.
- Entsorgen Sie alle Plastiktüten sicher und bewahren sie ausserhalb der Reichweite von kleinen Kindern auf.
- Halten Sie Kinder vom Aufbaubereich fern.
- Während des Aufbaus sollten Sie sich nicht gegen das Gewächshaus lehnen oder es drücken.
- Bauen Sie Ihr Gewächshaus nicht an Orten mit hoher Windbelastung auf.
- Versuchen Sie nicht, dieses Gewächshaus aufzubauen wenn Sie müde sind, unter dem Einfluss von Drogen oder Alkohol stehen oder zu Schwindelanfällen neigen.
- Heisse Geräte wie kürzlich benutzte Grills, Schneidbrenner usw. dürfen nicht im Gewächshaus gelagert werden. Vergewissern Sie sich vor Einsetzen der Pflöcke, dass sich keine versteckten Rohre oder Kabel im Boden befinden.
- Dieses Produkt ist nur für den Einsatz als Gewächshaus geeignet.

» Pflege und Wartung

Benutzen Sie eine milde Reinigungslösung für die Reinigung Ihres Gewächshauses und spülen es danach mit kaltem, sauberem Wasser ab. Benutzen Sie AUF KEINEN FALL Azeton, Scheuermittel oder andere spezielle Reinigungsmittel, um die klaren Platten zu reinigen.

» Werkzeuge & Ausrüstung

T001

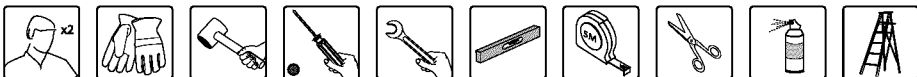

» Vor dem Zusammenbau

Diese ist eine Mehrteilige Montage. Der Zusammenbau der Teile wird am besten von zwei Leuten bewältigt. Rechnen Sie mit mindestens einem halben Tag für den Zusammenbau.

Wahl des Standorts - das Gewächshaus muss auf einem flachen ebenen Untergrund aufgebaut und fixiert werden. Wählen Sie eine sonnige Stelle ohne überhängende Bäume.

Wir empfehlen Ihnen sehr Ihr Gewächshaus direkt auf einem soliden Betonfundament zu befestigen. Dazu sollten Sie die vorgebohrten Löcher in der gelieferten Metallbasis benutzen.

Nehmen Sie alle Teile aus der Verpackung. Sortieren Sie die Teile und überprüfen Sie sie mit Hilfe der Inhaltsliste auf Vollständigkeit.

» Während des Zusammenbaus

Führen Sie den Aufbau in der in den Gebrauchsanweisungen aufgeführten Reihenfolge Schritt per Schritt aus.

Sie können Silikonfett- Spray verwenden, um das Schieben der Profile 924 auf die Anschlüsse zu erleichtern.



Sprühen Sie nicht auf die Polycarbonatplatten. Verwenden Sie den Gummihammer, falls nötig.

Schritt 3: Teil A994, A995 sind in der Rückseite des Gewächshauses und deren Festsetzung bestimmt die Vorderseite des Gewächshauses.

Schritt 10: Vergewissern Sie sich, dass die Basis sowohl quadratisch als auch waagrecht ist, indem Sie die Diagonalen messen und die Basis mit einer Wasserwaage prüfen.

Befestigen Sie das Gewächshaus auf eine endgültige Position direkt nach Beendigung des Aufbaus auf einem waagrechten Untergrund.

Schritte 15: Teil 7180 ist für die Montage Hilfe verwendet.

Steps 29: Entfernen Sie Teil 7180 und entsorgen.

Schritt 50+51: Bitte wiederholen Sie die Schritte 47-49 und verwenden Sie die in diesem Handbuch erwähnten Artikelnummern.

Schritt 70: Falls das Fenster nicht ordnungsgemäß verschlossen ist, bitte lösen Sie die Schrauben, Stellen Sie die Profile Zu und Befestigen Sie wieder die Schrauben.

Alle Schrauben befestigen nach dem abschluss der Montage.

Les vis 411 et écrous 412 servent tout au long de la procédure.

- Les vis 411 se placent à l'extérieur et les écrous 412 à l'intérieur de la serre.
- S'il n'est pas spécifié autrement, Ne serrez les vis et écrous (411 & 412) que de 2 à 3 tours, pas plus. Ne les serrez pas tant que l'assemblage n'est pas complètement terminé, sauf indication contraire. Ces deux icônes indiquent si le serrage des vis est nécessaire ou non.
- Cependant, la réalisation de certaines étapes peut nécessiter le serrage provisoire de quelques vis pour empêcher un profilé de tomber en attendant qu'il soit entièrement intégré à l'ensemble de la structure dans les étapes suivantes.

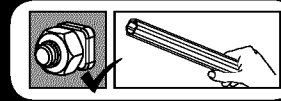
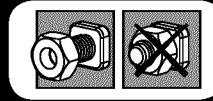

IMPORTANT !

Veillez lire attentivement ces instructions avant de commencer à monter votre serre. Conservez ces instructions en lieu sûr pour toute consultation ultérieure.

 Lorsque vous rencontrez l'icône d'information, veuillez vous référer à l'étape d'assemblage approprié pour remarque et assistance additionnels.

 Cette icône indique que le constructeur doit ce placer à l'intérieur du produit.

» Service clientèle

Pour toute assistance concernant le montage de la serre ou ses pièces de rechange – veuillez consulter notre site Internet ou appeler notre service technique (dont le numéro de téléphone figure sur la couverture de la brochure).

Pour en savoir plus, n'hésitez pas à visiter notre site Internet : www.palramapplications.com

» Consignes de sécurité

- Très important ! Veuillez suivre scrupuleusement les instructions de cette brochure et réaliser les étapes dans l'ordre énoncé.
- Nous recommandons vivement le port de gants de protection pendant le montage.
- Portez toujours des chaussures de travail et des lunettes de protection lorsque vous travaillez des pièces en aluminium extrudé.
- Lors de l'utilisation d'une échelle ou d'outils électriques, assurez-vous de bien suivre les consignes de sécurité du fabricant.
- Veillez à ne pas toucher de câbles aériens avec les profilés en aluminium.
- N'essayez pas de monter la serre s'il y a du vent ou s'il fait humide.
- Jetez tous les sacs en plastique en appliquant les règles de sécurité et maintenez-les hors de portée des jeunes enfants.
- Eloignez les enfants de la zone d'assemblage.
- Ne vous appuyez pas contre la serre et ne la poussez pas pendant le montage.
- Ne positionnez pas la serre dans un endroit trop exposé au vent.
- N'essayez pas de monter la serre si vous êtes fatigué, si vous êtes sous l'effet de drogues, de médicaments ou d'alcool ou encore si vous êtes sujet aux vertiges.
- Les objets chauds tels qu'un barbecue, un chalumeau ou autre article ayant été récemment utilisés, ne doivent pas être rangés dans la serre.
- Avant de planter les piquets, assurez-vous qu'aucun tuyau ni câble n'est enterré à l'endroit sélectionné pour l'installation.
- Ce produit est conçu pour servir de serre exclusivement.

» Entretien & Maintenance

Pour nettoyer votre serre, utilisez une solution détergente douce et à rincez à l'eau claire et froide. NE PAS utiliser d'acétone ni de produits nettoyants ou autres détergents spéciaux pour nettoyer les panneaux clairs. Il est recommandé de vérifier régulièrement que les couvre-joints des panneaux du toit sont bien en place (pièces en plastique 329 & profilé 981).

» Outils & Equipement

- T001 – outil spécial pour vis 411 et écrous 412

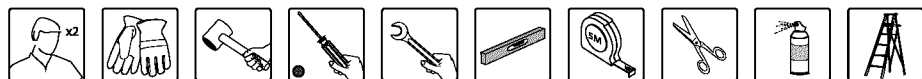
**» Avant le montage**

Il s'agit d'un assemblage à pièces multiples qu'il est préférable de réaliser à deux personnes et auquel il faut consacrer au moins une demi-journée.

Sélection du site – la serre doit être montée et fixée sur une surface plane.

Choisissez un emplacement ensoleillé et éloigné d'éventuels arbres susceptibles de la surplomber.

Nous recommandons vivement de fixer la serre directement à de solides fondations en béton. Pour ce faire, utilisez les trous déjà percés dans le châssis métallique fourni.

Sortez toutes les pièces de leurs emballages. Triez-les et comparez-les avec la liste des pièces pour vérifiez que tout y est.

Lors de l'assemblage, les pièces doivent être disposées à portée de main. Gardez toutes les petites pièces (vis, etc.) dans un récipient pour éviter de les perdre.

» Pendant le montage

Procédez au montage étape par étape, en respectant l'ordre énoncé dans cette brochure.

Vous pouvez utiliser un spray lubrifiant en silicone afin de vous aider à insérer les profils dans les connecteurs. Veillez à ne pas asperger les panneaux de polycarbonate. Utilisez le maillet en caoutchouc si nécessaire tout en prenant soin de ne pas abîmer les connecteurs en plastique.



Etape 3: La pièce 7063 est le seuil de la serre. Sa fixation détermine la façade de la serre.

Etape 10: Assurez-vous que la base soit bien carrée en mesurant les diagonales et le nivelage à l'aide d'un niveau à bulle.

Connectez fermement la serre à sa position finale immédiatement après l'achèvement du montage.

Etape 15: Partie 7180 est utilisé pour l'assistance de montage.

Etape 29: Suppression de la partie 7180 et le jeter.

Etapes 50+51: Veuillez répéter les étapes 47-49 et travaillez selon les numéros de pièces mentionnés dans le manuel.

Etape 70: Dans le cas où la fenêtre ne ferme pas correctement, veuillez relâcher les vis, ajuster le profil, et de nouveau resserrer les vis. Serrez toutes les vis après avoir achever l'assemblage.

Les vis 411 et écrous 412 servent tout au long de la procédure.

- Les vis 411 se placent à l'extérieur et les écrous 412 à l'intérieur de la serre.
- S'il n'est pas spécifié autrement, Ne serrez les vis et écrous (411 & 412) que de 2 à 3 tours, pas plus. Ne les serrez pas tant que l'assemblage n'est pas complètement terminé, sauf indication contraire. Ces deux icônes indiquent si le serrage des vis est nécessaire ou non.
- Cependant, la réalisation de certaines étapes peut nécessiter le serrage provisoire de quelques vis pour empêcher un profilé de tomber en attendant qu'il soit entièrement intégré à l'ensemble de la structure dans les étapes suivantes.

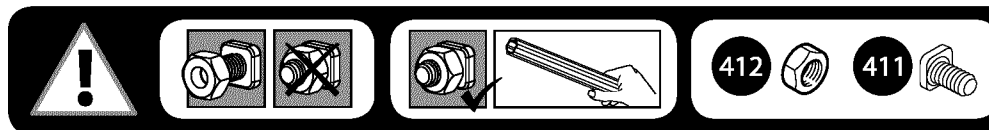

IMPORTANTE

Por favor, lea estas instrucciones cuidadosamente antes de empezar a montar este invernadero. Mantenga estas instrucciones en un lugar seguro para referencia futura.



Durante el montaje encontrará el icono de información, por favor refiérase a la etapa de montaje correspondiente para comentarios adicionales y asistencia.



Este icono indica al instalador que deberían estar en el interior del producto.

» Servicio de Ayuda al Cliente

Para obtener ayuda con el montaje o para las piezas de recambio - por favor entre a nuestro sitio web o llame a nuestra línea de servicio (el número está en la página de título). Información adicional se puede encontrar en nuestro sitio web: www.palramapplications.com

» Consejo de Seguridad

- Es de suma importancia montar todas las partes de acuerdo con las instrucciones. No se salte ningún paso.
- Recomendamos firmemente el uso de guantes de trabajo durante el montaje.
- Use siempre zapatos y gafas de seguridad al trabajar con aluminio extruido.
- Al usar una escalera plegable o herramientas eléctricas asegúrese de que sigue las instrucciones de seguridad de los fabricantes.
- No toque los cables eléctricos aéreos con los perfiles de aluminio.
- No intente montar el invernadero en días de viento o días con humedad.
- Disponga todas las bolsas plásticas en lugar seguro - guárdelas fuera del alcance de niños.
- Mantenga a los niños fuera del área de montaje.
- No se apoye ni empuje el invernadero durante la construcción.
- No coloque su invernadero en un área expuesta al viento excesivo.
- No intente montar este invernadero si usted está cansado, ha tomado drogas o alcohol o si usted es propenso a ataques de mareo.
- Artículos calientes recientemente usados tales como parrillas, sopletes etc. no deben ser almacenados en el invernadero. Asegúrese de que no haya ninguna tubería o cables ocultos en la tierra antes de insertar las clavijas.
- Este producto es designado a ser usado solamente como invernadero.

» Cuidados & Mantenimiento

Cuando su invernadero necesite limpieza, utilice una solución detergente suave y enjuague con agua limpia fría. NO UTILICE acetona, limpiadores abrasivos u otros detergentes especiales para limpiar los paneles. Se recomienda comprobar periódicamente que los paneles del techo > tapones (parte de plástico 329 y perfil 981) están colocados en el lugar.

» Herramientas & Equipos

T001 – Herramienta especial para Tornillos 411 y Tuercas 412

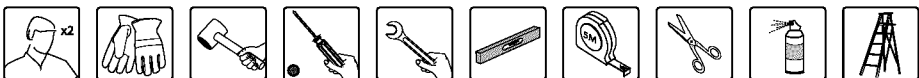

» Antes del Montaje

Esto es un montaje de varias partes, mejor ejecutado por dos personas. Dé un plazo de por lo menos medio día para el proceso de montaje.

Seleccionar un sitio – el invernadero debe ser montado, posicionado y fijo en una superficie plana.

Elija un lugar soleado lejos de árboles con ramas colgantes.

Recomendamos firmemente que fije su invernadero directamente a una fundación de concreto sólido. Al hacer esto, utilice los agujeros preperforados en la base de metal proveída.

Saque todas las partes componentes de los paquetes. Clasifique las partes y compruebe contra la lista del contenido.

Durante el montaje las partes deben ser colocadas cerca del alcance de la mano. Guarde todas las piezas pequeñas (tornillos etc.) en un tazón para que no se pierdan.

» Durante el Montaje

Ejecute los pasos del montaje en el orden indicado en las instrucciones.

Usted puede utilizar el aerosol de lubricante de silicona para ayudar a deslizar los perfiles en los conectores. No rocíe los paneles de policarbonato. Use el mazo de goma si fuere necesario.



Paso 3: Partes 7063 están en la parte posterior del invernadero. Fijándolas se determina la parte delantera del invernadero.

Paso 10: Cerciórese de que la base sea cuadrada midiendo las diagonales y el nivel usando un nivel de burbuja.

Conecte firmemente el invernadero a un nivel de posición final inmediatamente después de la finalización de la asamblea.

Pasos 15: Parte 7180 se utiliza para la asistencia en el armado.

Paso 29: Retire y deseche la parte 7180.

Pasos 50+51: Por favor, repita los pasos 47-49 y trabajar de acuerdo con el id partes mencionadas en este manual.

Paso 70: En caso de que la ventana no se cierra correctamente, afloje los tornillos, ajustar el perfil y apretar el tornillo.

Apriete todos los tornillos de montaje al completar

- Screws 411 and nuts 412 are used throughout the assembly process.
- Screws 411 are to be assembled from the outside and nuts 412 from the inside of the greenhouse.
- If not specified otherwise, do not fasten screws and nuts (411 & 412) more than 2-3 turns only. Do not tighten them until completion of the panels' assembly. These 2 icons indicate if screws' tightening is required or not.
- However, in some steps, temporary tightening of a few screws may be needed to prevent a profile from falling till it will be fully connected in the next steps.

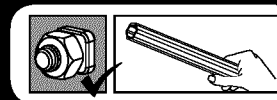
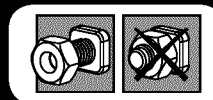

412





411



Viktigt

Läs noga igenom dessa instruktioner innan ni börjar montera växthuset.
Förvara dessa instruktioner på en säker plats för framtida referenser.

 Kun kohdataan tietojen kuvake, katso asiaa kokoonpanoon askel lisäkommentteja ja apua.

 Tämä kuvake ilmaisee, että asentaja olisi sisällä tuotteen.

» Asiakas palvelu

Jos tarvitset apua / neuvoja asennukseen tai osien vaihtoon – käänny meidän kotisivujen, sähköpostin puoleen tai soita jälkimerkintöimme (tiedot löytyvät kansilehdestä).
Lisäinformaatiota löydät valmistajan sivuilta www.palramapplications.com

» Turvallisuus ohje

- Ensijaisena tärkeää on noudattaa asennusohjeen järjestystä ja ohjeita – älä jätä mitään tekemättä.
- Suosittelemme suojakäsineiden käyttöä asennustyössä.
- Käytä aina tukevia kenkiä ja suojalaseja työskennellessäsi metallituotteiden kanssa.
- Jos käytät tikkaita, apuvälineitä, akkuporakonetta - varmista aina myös työkalu valmistajan käyttöohjeet.
- Älä kosketa sähköjohtoja tai lähteitä metallisten esineiden kanssa.
- Älä yritä pystyttää / asentaa kasvihuonetta tuulisella, sateisella tai huonolla säällä.
- Hävitä huolellisesti kaikki muoviset pakkaustuotteet ja varmista ettei ne pääse pienten lasten lähetyville.
- Pidä lapset loitolla työskentely alueelta ja pidä myös alue aina siistinä.
- Älä työnnä tai nojaa kasvihuoneen rakenteisiin asennusvaiheen aikana.
- Valitse huolella kasvihuoneen sijainti, siten ettei se ole alttiina kovalle tuulelle tai ylimääräisille lumikuormille.
- Älä yritä asentaa tätä kasvihuonetta puolikuntoisena, väsyneenä, päihteiden taikka lääkityksen vaikutuksen alaisena.
- Kuumat tuotteet kuten grillit, polttotyökalut, terassilämmittimet tulee säilöä muulla kuin kasvihuoneessa. Varmista että maahankiinnitys on turvallista ja ettei maaperässä ole putkia tai sähköjohtoja. Tämä tuote on suunniteltu ainoastaan kasvihuoneeksi.

» Huolto & ylläpito

Kun kasvihuoneesi kaippaa pesua & puhdistusta, käytä ainoastaan mietoa saippuavettä ja huuhtelee runsaalla kylmällä vedellä. ÄLÄ KÄYTÄ acetononia, liuottimia tai muita voimakkaita puhdistusaineita – ei myöskään mäntyöljypohjaisia aineita.
On suositeltavaa että asennuksen kunto tarkistetaan säännöllisesti, kattolevyt > kiinnikkeet (muoviset osat 329 & profiilit 981) ovat paikoillaan.

» Työkalut & Välineet

- T001 (valmistajan tekemä erikoistyökalu, mukana toimituksessa) 

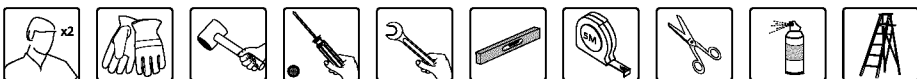
**» Ennen Asennustyötä**

Tämä on moniosainen asennustyö joka hoituu parhaiten min. kahden asentajan toimesta. Varaa aikaa kasvihuoneen pystytykselle vähintään puoli päivää. Ennen sitä tulee kasvihuoneen perusta valmistaa huolella valittuun paikkaan.

Varmista että perustan mitat vastaavat kasvihuoneen sokkelin mittoja.

Kasvihuoneen sijainnin valinnassa tulee huomioida seuraavat seikat, perustan tulee

olla suora, mielellään aurinkoinen

sijainti poissa puiden oksien läheisyydestä. Samoin sijainnin tulisi olla paikassa jossa sen päälle ei pääse putoamaan lunta tai jäätä toisesta rakennuksesta. Kovin tuulista sijaintia tulisi myös välttää. Kasvihuone tulee kiinnittää tukevasti perustaan metallisokkelilla. Metallisokkelin alareunassa on valmiit kiinnityspisteet. Aloita tyhjentämällä pakkaukset ja varmistamalla että kaikki tarvittavat nimetyt osat löytyvät – tarkista koontiluettelosta tuotteet & määrät.

» Asennuksen Yhteydessä

Suorita kokoamisvaiheet ohjeissa esitetystä järjestyksessä.

Voit käyttää silikonivoiteluainetta profiilien liu'uttamiseen helpommin liittimiin. Älä suihkuta voiteluainetta polykarbonaattipaneelisiin. Käytä tarvittaessa kumipäistä vasaraa. Varo täristästä muovisia liittimiä.



Vaihe 3: Osa 7063 on kasvihuoneen kynnyksen. Sen asentaminen määrittää kasvihuoneen etupuolen.

Vaihe 10: Varmista, että sokkeli on neliömittaamalla pituus kulmasta kulmaan, ja että se on vaakasuorassa käyttämällä vesivaakaa.

Kiinnitä kasvihuone välittömästi kokoamisen jälkeen pysyvään sijaintipaikkaan tasaiselle alustalle.

Vaihe 15: Part 7180 käytetään kokoonpanoon apuun.

Vaihe 29: Poista Part 7180 ja hävitä.

Vaihe 50+51: Toista vaiheet 47-49 ja mukaan toimivia osia id mainittu tässä oppaassa.

Vaihe 70: Jos ikkuna ei ole kunnolla kiinni, ota vapauta ruuvit, säädä profiiliin ja kiristä ruuvi.

Kiristä kaikki ruuvit täyttäessään kokoonpano.

- Ruuveja 411 ja muttereita 412 käytetään koko kokoamisprosessin ajan.
- Ruuvit 411 täytyy asentaa kasvihuoneen ulkopuolelta ja mutterit 412 kasvihuoneen sisäpuolelta.
- Ellei toisin ilmoiteta, älä kiristä ruuveja ja muttereita (411 & 412) enempää kuin 2-3 kierrosta. Älä kiristä ennen kuin levyjen asennus on valmis. Nämä 2 kuvaketta osoittavat, täytyykö ruuveja kiristää vai ei.
- Joissakin vaiheissa ruuvien tilapäistä kiristämistä voidaan kuitenkin tarvita estämään profiilin kaatumisen ennen kuin se on kokonaan kiinnitetty seuraavissa vaiheissa.

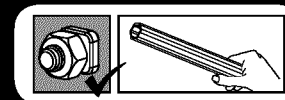
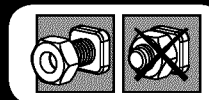

VIGTIGT

Læs disse instruktioner omhyggeligt, inden du begynder at samle drivhuset.
Opbevar disse instruktioner på et sikkert sted til senere brug.

 Når støder ikonet, information, henvises der til den relevante samling skridt for yderligere kommentarer og assistance.

 Dette ikon angiver, at installatøren skal være inde i produktet.

» Kundeservice

For hjælp til samlingen eller til reservedele, gå venligst til vores websted eller ring til vores kundeservice (nummeret findes på forsiden).

Yderligere oplysninger findes på vores websted: www.palramapplications.com

» Sikkerhedsadvarsel

- Det er meget vigtigt, at alle dele samles i henhold til anvisningerne. Spring ikke noget trin over.
- Vi anbefaler stærkt, at der anvendes arbejdshandsker under samlingen.
- Vær altid iført sko og anvend sikkerhedsbriller, når der arbejdes med ekstruderet aluminium.
- Hvis der bruges en trappestige eller elektrisk værktøj, skal producentens sikkerhedsanvisninger følges.
- Berør ikke luftledninger med aluminiumsprofilerne.
- Forsøg ikke at samle drivhuset, når det blæser eller er vådt i vejret.
- Bortskaf alle plastikposer på sikker måde. Hold dem udenfor små børns rækkevidde.
- Hold børn væk fra stedet, hvor samlingen foregår.
- Læn dig ikke mod drivhuset og skub ikke til det under monteringen.
- Anbring ikke drivhuset på et sted med kraftig vind.
- Forsøg ikke at samle drivhuset, hvis du er træt, er under indflydelse af narkotika, medicin eller alkohol, eller hvis du har tendens til svimmelhed.
- Varme ting såsom netop brugte griller, blæselamper osv må ikke opbevares i drivhuset. Inden du anbringer naglerne, skal du kontrollere, at der ikke findes skjulte rør eller kabler i jorden.
- Dette produkt er kun beregnet til at blive brugt som drivhus.

» Pasning og vedligeholdelse

Rengør drivhuset med en mild sæbeopløsning og skyl efter med rent, koldt vand. Brug IKKE acetone, slibende rengøringsmidler eller andre særlige rengøringsmidler til rengøring af de gennemsigtige paneler.

» Værktøj og udstyr

T001

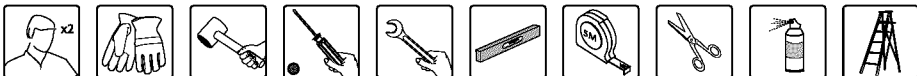
**» Før Montering**

Denne er en montering i flere etaper bedst udført af to personer. Sæt mindst en halv dag til side til monteringsprocessen.

Valg af sted – drivhuset skal placeres og opsættes på en flad, jævn overflade.

Vælg et solrigt sted langt fra overhængende træer.

Vi anbefaler på det stærkeste at fastgøre dit drivhus direkte på et solidt beton fundament. I det dette udføres brug de på forhånd borede huller i den leverede metal bund.

Tag alle componenter ud af emballagerne. Sorter alle delene og sammenhold med indholdslisten.

» Under Montering

Udfør monteringstrinene i rækkefølgen anvist i brugsanvisningen.

Du kan bruge Silicon smøremiddel spray for at hjælpe dig skub profiler på stikkene. Sprøjt ikke Polycarbonat paneler. Brug gummi Malet om nødvendigt.



Trin 3: Del 7063 er på bagsiden af drivhuset. Opsætning af dem afgør drivhusets front.

Trin 10: Sikre at fundamentet er firkantet ved at måle diagonalerne og planere ved hjælp af et vaterpas.

Drivhuset skal fastgøres til en planeret slutposition umiddelbart efter monterings afslutning.

Trin 15: Del 7180 bruges til hjælp til monteringen.

Trin 29: Fjern Part 7180 og kasseres.

Trin 50+51: Venligst gentage trin 47-49 og arbejder efter de dele id nævnt i denne vejledning.

Trin 70: I tilfælde af vinduet ikke er lukket korrekt, skal du frigive skruerne, juster profil og stram skruen.

Spænd alle skruer, når du gennemfører samling.

Skruerne 411 og møtrikkerne 412 bruges under hele samlingen.

- Skruer 411 skal skrues i udefra og møtrikkerne sættes på indenfor i drivhuset.
- Stram ikke skruer og møtrikker (411 og 412) mere end to-tre omgange. Hvis ikke andet er anført, skal de ikke strammes, før panelerne er samlet. Disse 2 ikoner viser, hvis skruer 'stramning' er nødvendig eller ej.
- Dog, ved visse trin, kan midlertidig stramning af nogle få skruer være nødvendig for at forhindre en profil i at falde indtil den bliver helt forbundet i de næste trin.

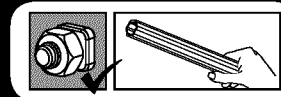
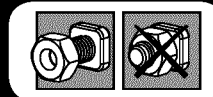

412



411



Viktigt

Läs noga igenom dessa instruktioner innan ni börjar montera växthuset.
Förvara dessa instruktioner på en säker plats för framtida referenser.

 När du stöter information ikonen, se respektive församling steg för ytterligare kommentarer och hjälp.

 Denna ikon indikerar att installatören ska vara inne i produkten.

» Kundservice

För rådgivning av montering eller byte av delar – vänligen kontakta oss via e-mail eller telefon (nummer finns på förstasidan).

Ytterligare information finns på producentens hemsida: www.palramapplications.com

» Säkerhetsföreskrifter

- Följ monteringsanvisningarna i den ordning som anvisas i instruktionerna, hoppa inte över något steg.
- Vi rekommenderar att handskar, skor och skyddsglasögon alltid används då man arbetar med metallprofiler.
- Vid användning av stege, redskap och bormaskin, följ tillverkarens säkerhetsråd.
- Var noga med att inte komma i kontakt med elkablar då metallprofiler hanteras.
- Undvik att montera växthuset i dåligt, bläsigt väder eller regn.
- Ta väl hand om all plastpåsar och se till att de är utom räckhåll för barn.
- Låt inte barn vistas på monteringsplatsen och håll omgivningen snygg.
- Luta eller tryck inte på växthuset under montering.
- Välj omsorgsfullt platsen för växthuset så att det inte påfrestras av kraftig vind eller extra snö.
- Försök inte att sätta ihop denna produkt om du är trött, har tagit droger, druckit alkohol eller om du brukar ha yrselattacker.
- Heta föremål som en nyligen använd grill, blåslampa eller dylikt får inte förvaras i växthuset. Försäkra att det inte finns några dolda rör eller kablar i marken innan du slår ner metallfästena för att förankra växthuset.
- Denna produkt är endast avsedd för att användas som växthus.

» Underhåll & skötsel

När växthuset behöver rengöras skall du använda ett mildt rengöringsmedel och skölja rikligt med kallt och rent vatten. Använd inte acetone, slipande rengöringsmedel eller andra specialmedel för att rengöra panelerna. Vi rekommenderar att man tidvis kontrollerar takpanelernas fäste (även plastfästen 329 och profiler 981) och försäkrar deras rätta position.

» Verktyg & redskap

- T001 verktyg (inkl. förpackningen)

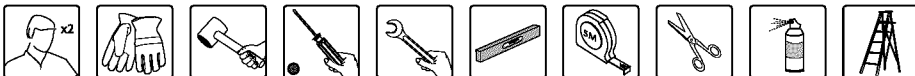
**» Före montering**

Detta är ett monteringsarbete som bäst utförs av min. två personer. Reservera åtminstone en halv dag för monteringsprocessen. Före monteringen bör grunden vara välgjord på den valda platsen.

Försäkra att grundens mått passar ihop med växthuset sockelmått. Vid val av växthuset positionering bör grunden vara rak. Välj en solig plats fri från skuggande träd och grenar. Is och snö från träd, grenar eller byggnader samt vindiga platser bör undvikas. Växthuset bör fästas stadigt i grunden med tillhörande metallsockel.

Metallsockeln har färdiga fästpositioner. Börja med att tömma förpackningen och försäkra att alla delar finns – kontrollera innehållsförteckningen att delarna är korrekt märkta samt att de finns i rätt mängd.

» Under montering

Utför montering i den ordning som anges i instruktionerna.

Du kan använda silikonprayen som hjälp för att glida profilerna på kopplingarna.

Spraya inte polykarbonatpanelerna. Använd gummihammare om det behövs.



Steg 3: Del 7063 är växthuset tröskel. Denna del bestämmer vilken sida som blir växthuset framsida.

Steg 10: Se till att botten är fyrkantig genom att mäta diagonaler. Använd vattenpass för att säkerställa att det är rakt.

Fäst växthuset ordentligt på en jämn plats omedelbart efter avslutad montering.

Steg 15: Del 7180 används som hjälp vid monteringen.

Steg 29: Ta bort och kasta del 7180.

Steg 50+51: Vänligen upprepa steg 47-49 och arbetar enligt den delar ID som nämns i denna handbok.

Steg 70: Om fönstret inte stängs ordentligt, lossa skruvarna, justera profilen och dra åt skruvarna.

Dra åt alla skruvar när du slutför monteringen.

Skruv 411 och mutter 412 används genom hela monteringsprocessen.

- Skruv 411 ska monteras från utsidan och mutter 412 från växthuset insida.
- Om inte annat anges, dra inte åt skruv och mutter (411 och 412) mer än 2-3 varv. Dra inte åt dem förrän monteringen av panelerna är avslutad. Dessa två ikoner anger om du behöver dra åt skruv eller inte.
- Tillfällig åtdragning kan i vissa steg behövas för att förhindra en profil från att falla tills den är fullt ansluten i kommande steg.

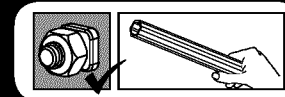
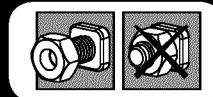

412







411





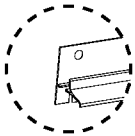
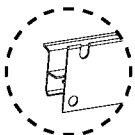

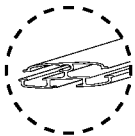
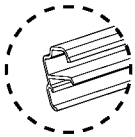
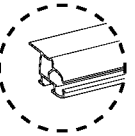
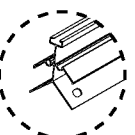
Contents

Item		Qty.	Item		Qty.	Item		Qty.
7457		2	7459		2	566		20
7456		2	7458		2	7453		2
7455		4	559		3	7180		2
7078		4	560		3	<p>EN For assembly use only DE Bitte NUR für die Montage verwenden FR Utiliser seulement pour l'assemblage SP Para el montaje utilizar sólo</p>		
7079		2	7452		3	7502		5
586		2	7454		6	7516		2

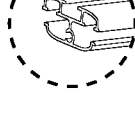
Contents

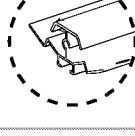
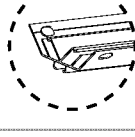
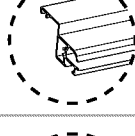
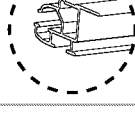
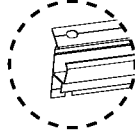





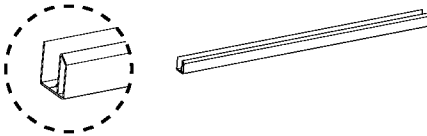
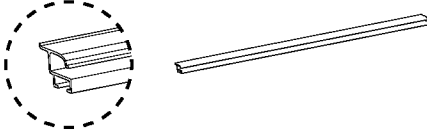
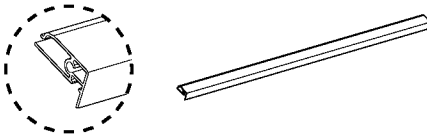
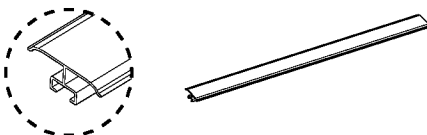
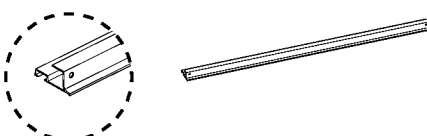
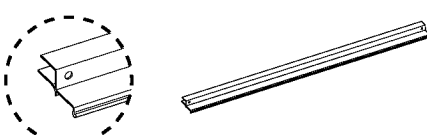
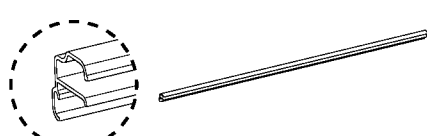

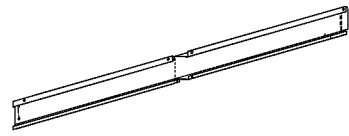
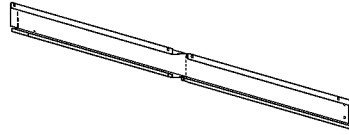
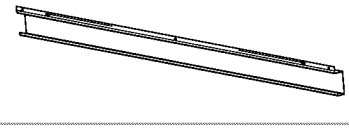
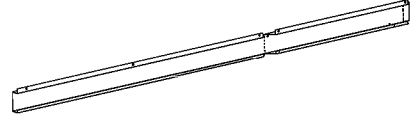
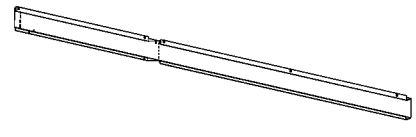
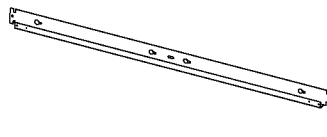
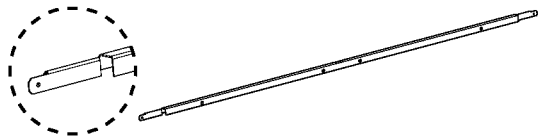
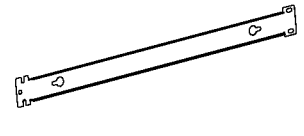

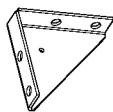
Item		Qty.
7487		1
7488		2
7489		2
7490		2
7491		4
7492		2
7494		3
7076		12

Item		Qty.
983		1
7068		3
7073		16
7493		4
7495		2
7496		2
7497		4
7498		2
7499		4
972		2

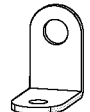

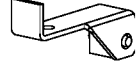
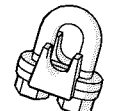

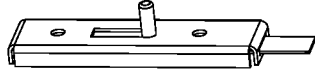





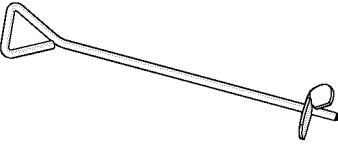
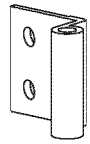

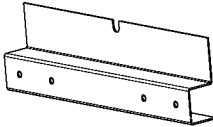
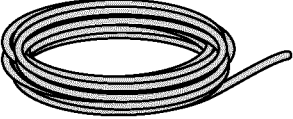
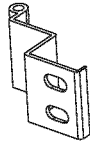

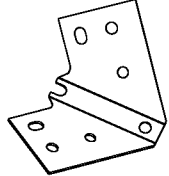
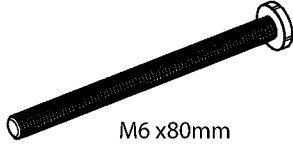

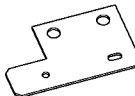
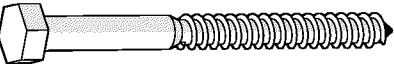

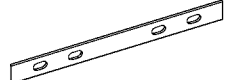
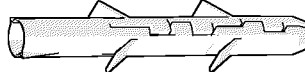
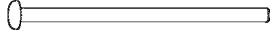
Contents

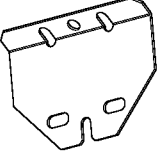
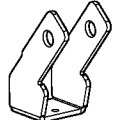
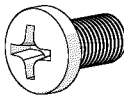
Item		Qty.
984		4
990		2
992		4
999		6
991		2
989		2
981		6

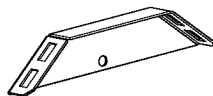
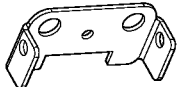
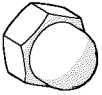

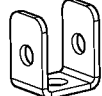

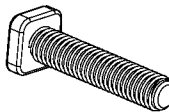

Item		Qty.
7448		2
7449		2
7060		3
7058		1
7059		1
7450		4
7063		2
286		2

Item		Qty.	Item		Qty.
7461		2	288		10
7451		2	7065		1
7331		4	7009		4 (+1)
7066		2	7333		4
7332		2			
7082		2			
T001		1			
96		6			

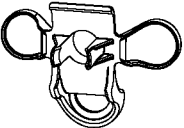
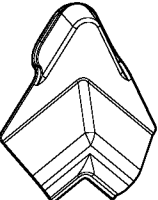
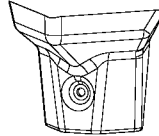
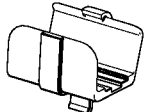
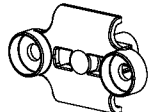
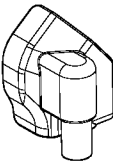
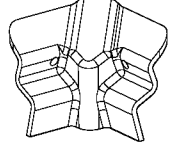
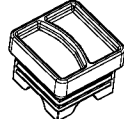
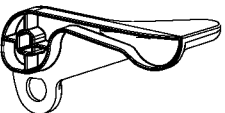
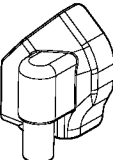
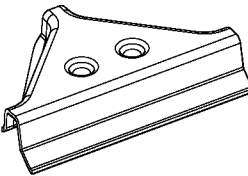
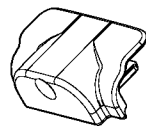
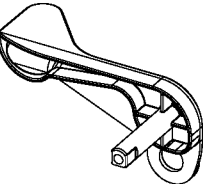
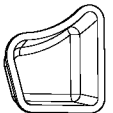
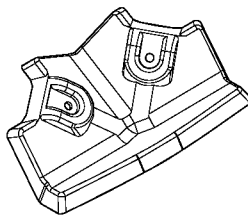
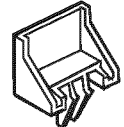
Contents

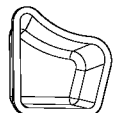
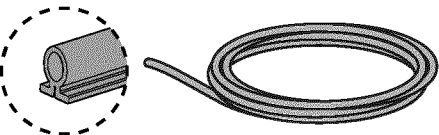
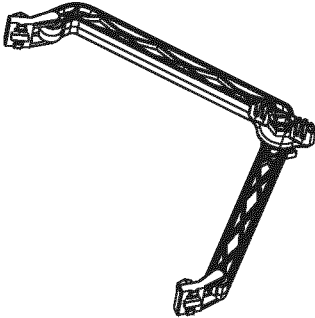
Item		Qty.	Item		Qty.	Item		Qty.	Item		Qty.
7460		1	7336		4	464		12	411		218 (+7)
7504		2	7327		2	462		6	412		226 (+7)
7446		4	7224	 M6 x80mm	2	465		24 (+3)	447		12 (+3)
7067		2	4000		4	422	 M4	24 (+3)	4008		31 (+4)
7518		1	4010		4	463		6	4043		9 (+3)
08		1	7583		2	7283	 M8x16	2	466	 M6	47 (+5)
459		2	7329		2	414	 M8	2	97	 M6	6 (+1)
			7330		2	433	 M8	7	421	 M4 x 16mm	4 (+1)
									422	 M4	4 (+1)
									461		16 (+4)
									7284		29 (+2)

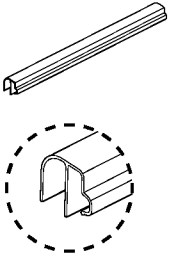
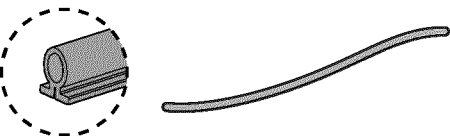
Contents

Item		Qty.	Item		Qty.	Item		Qty.	Item		Qty.
7086		1	343		3	7520		2	292		1
7085		1	344L		3	7500		2	1010		12 (+2)
7084		1	344R		3	7501		1	329		5
7083		1	7582		2	7531		1	328		40 (+6)
7088		1	7581		2	7271		1	99		2
423		1	318		42 (+2)	3017		4	22		4

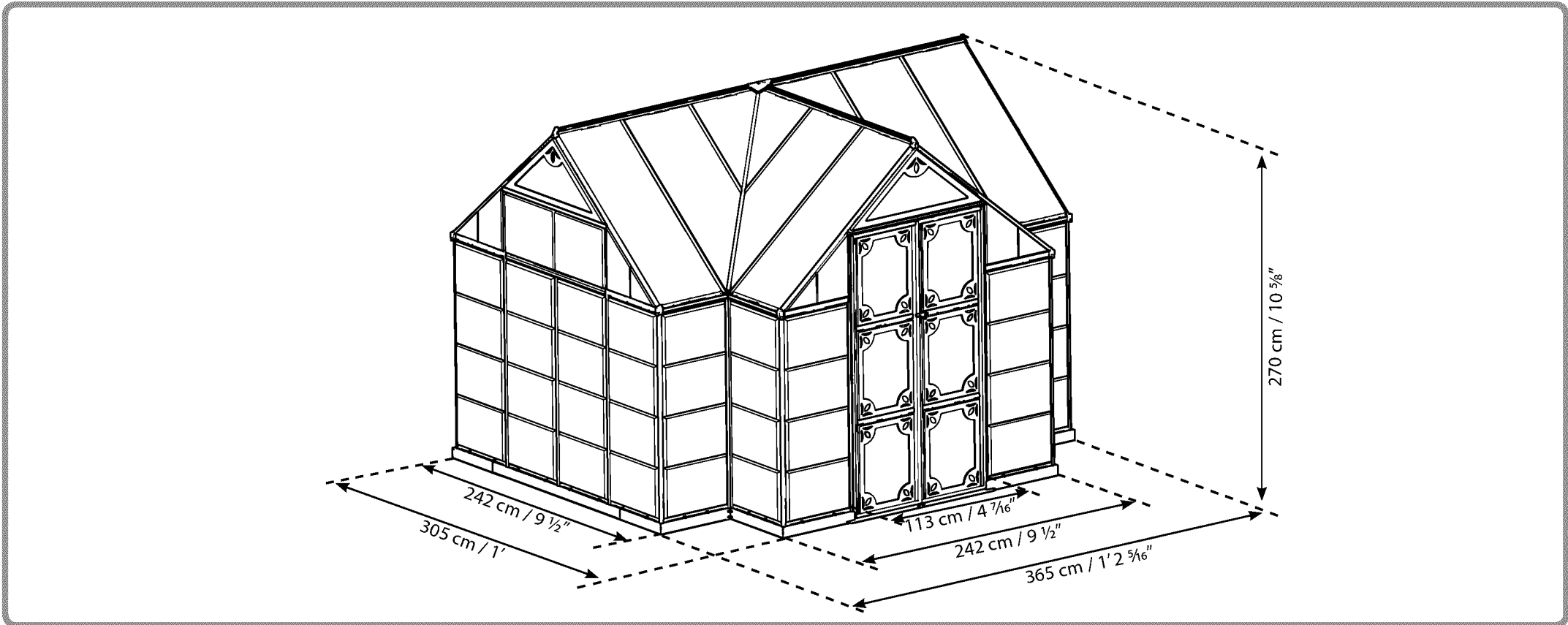
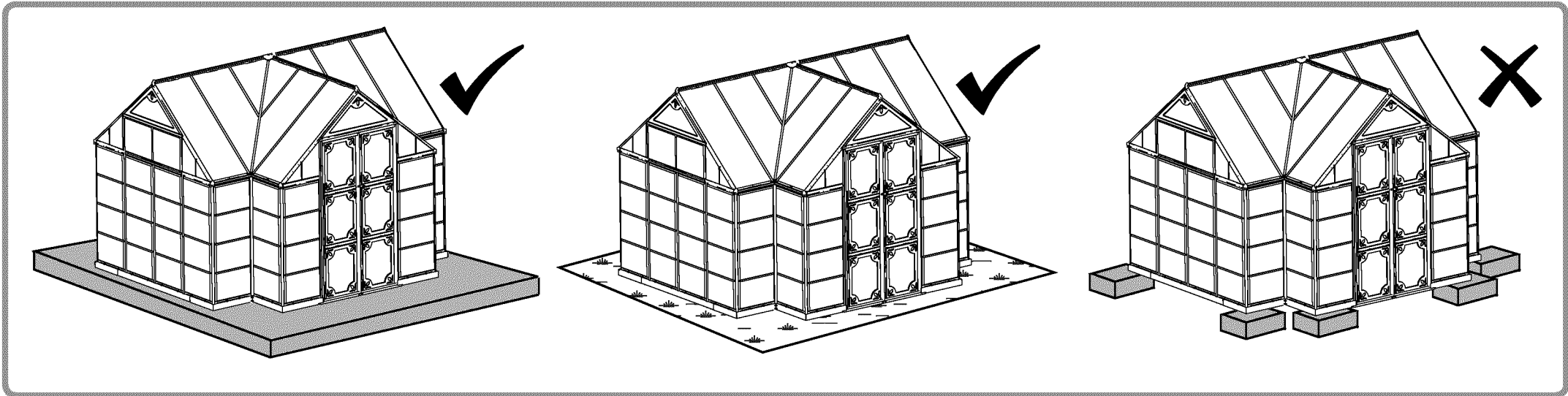

1

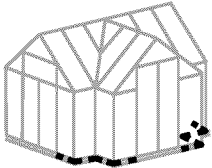

7448

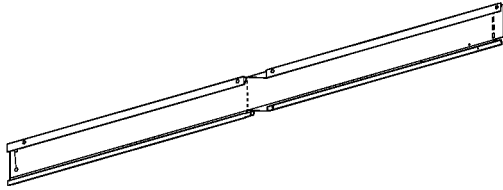

..... 2

7449

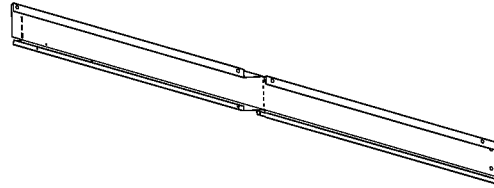

..... 2

447

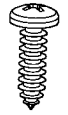

..... 4

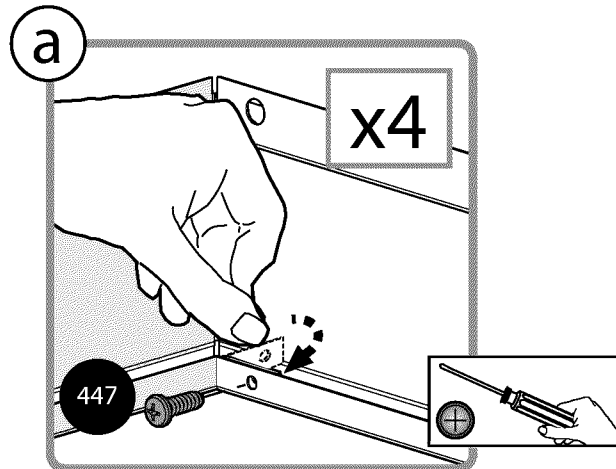
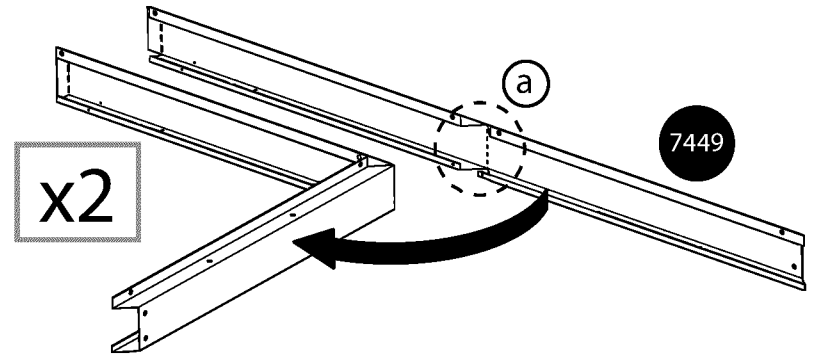
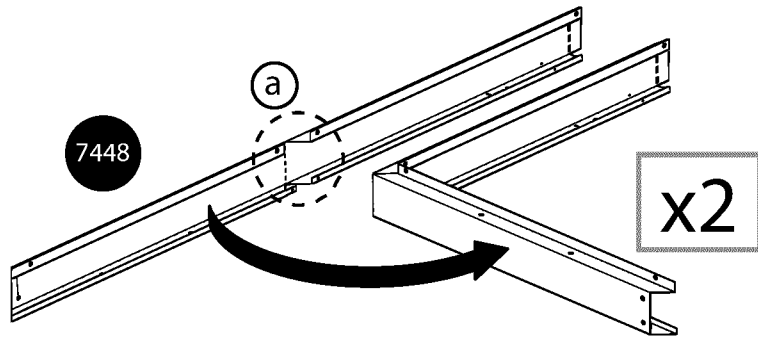

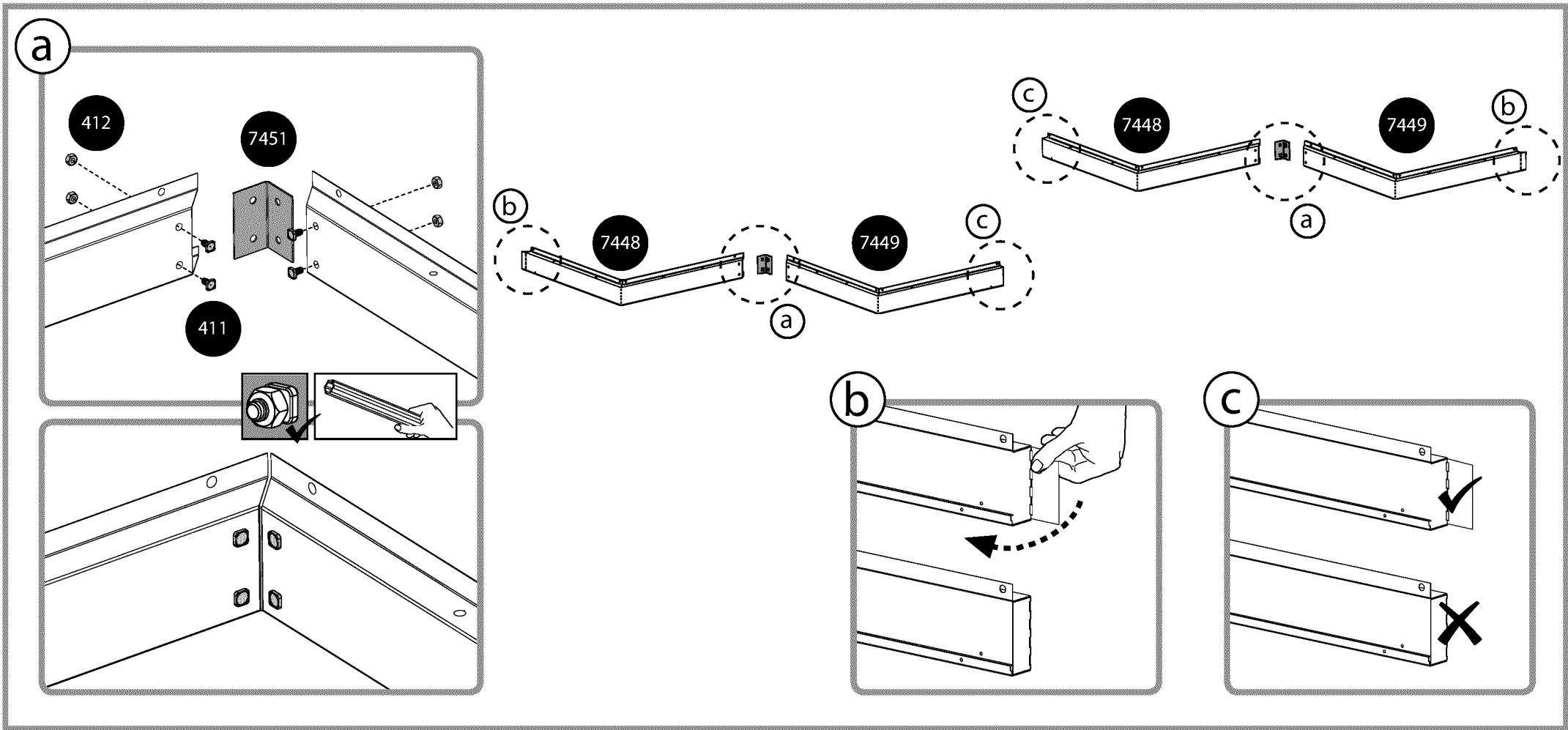
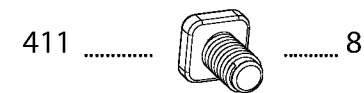
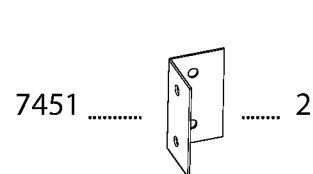
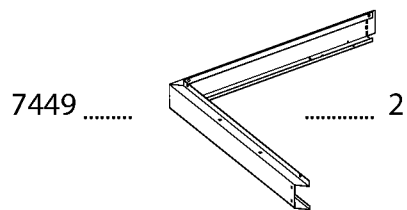
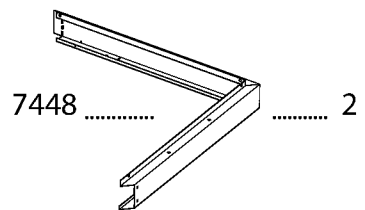
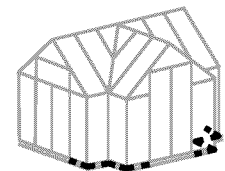

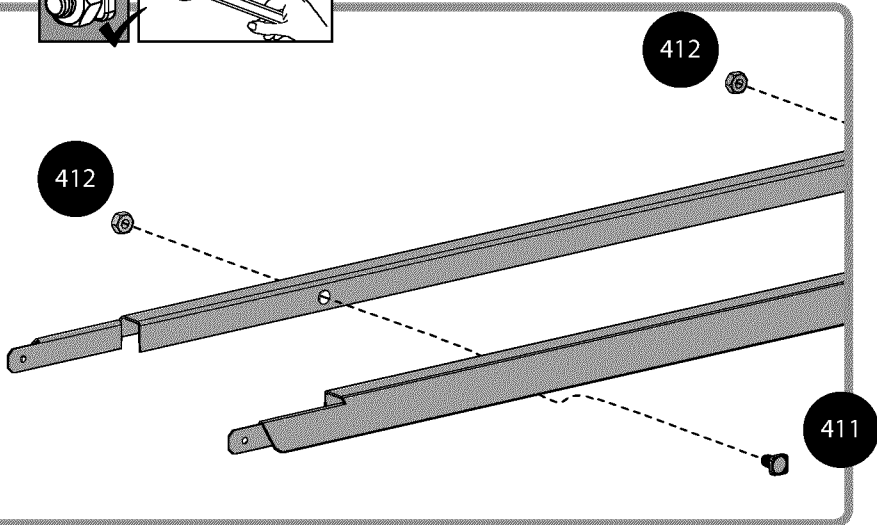
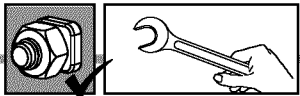
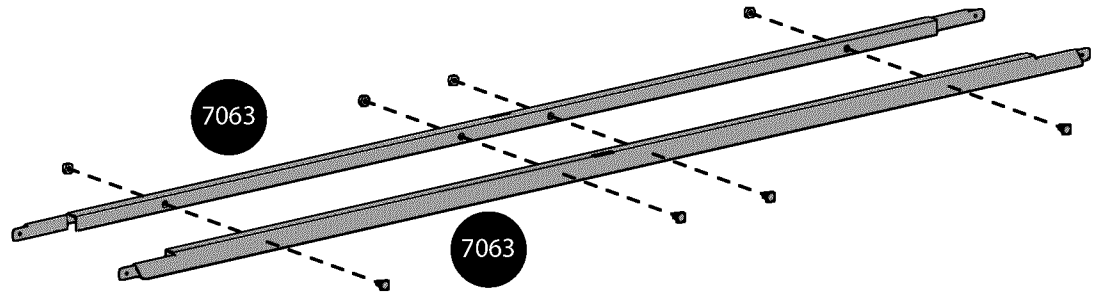
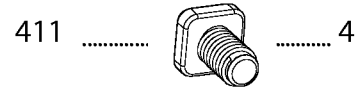
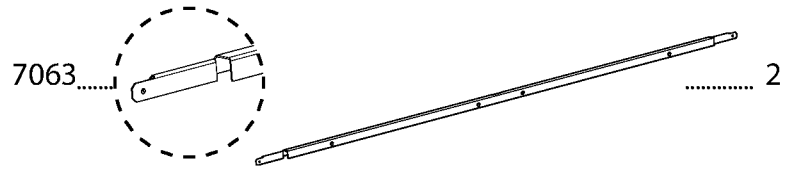
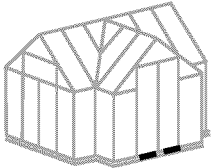

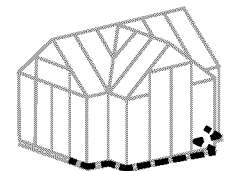

4008..... 4

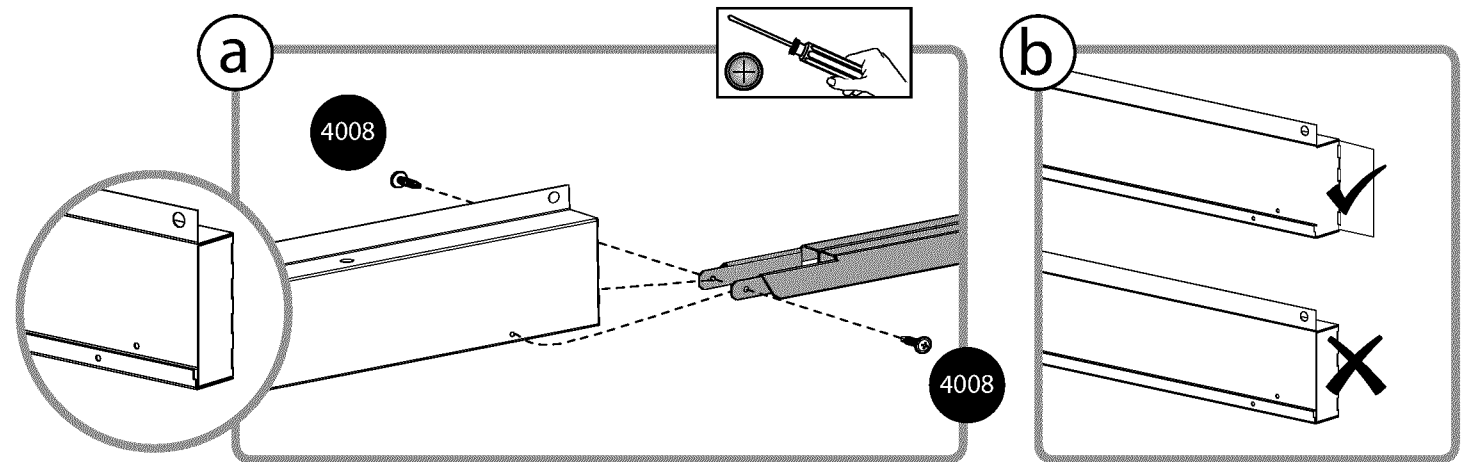
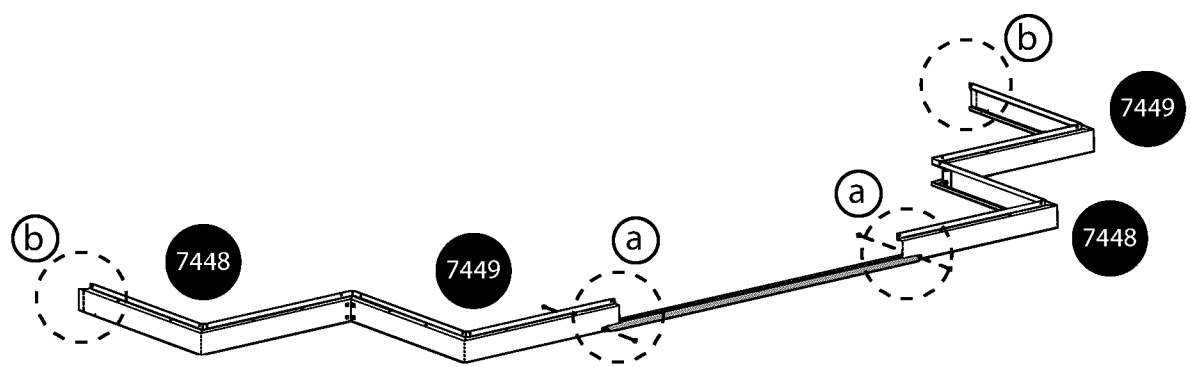
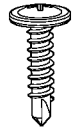

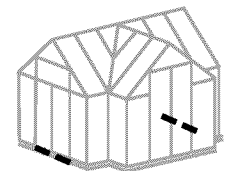

7060 2

411 2

412 2

7060

a

7060

a

7060

411

412

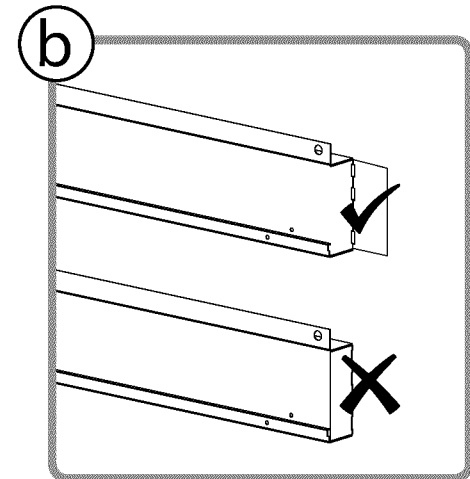
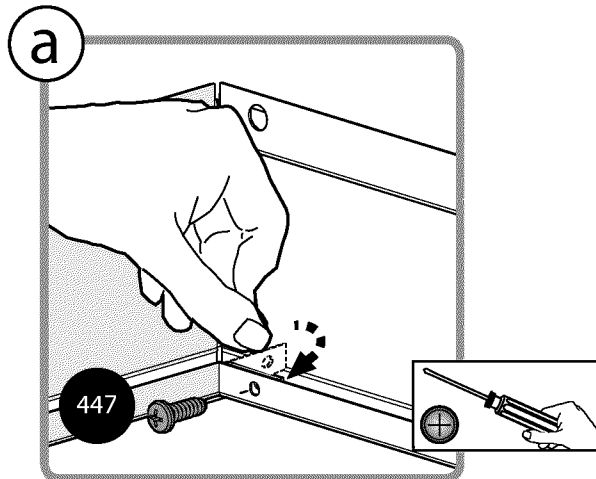
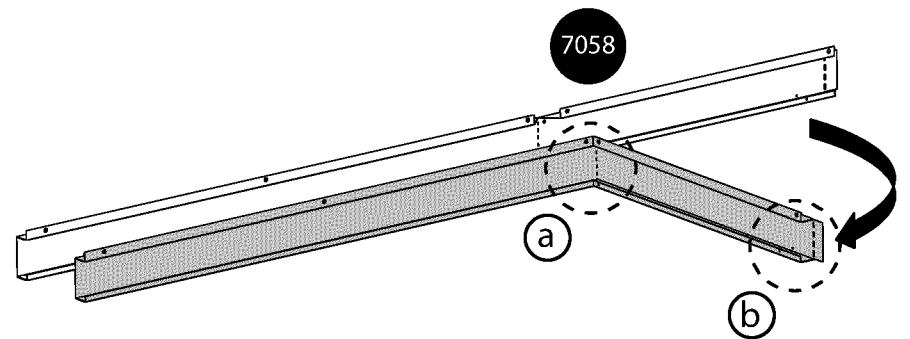
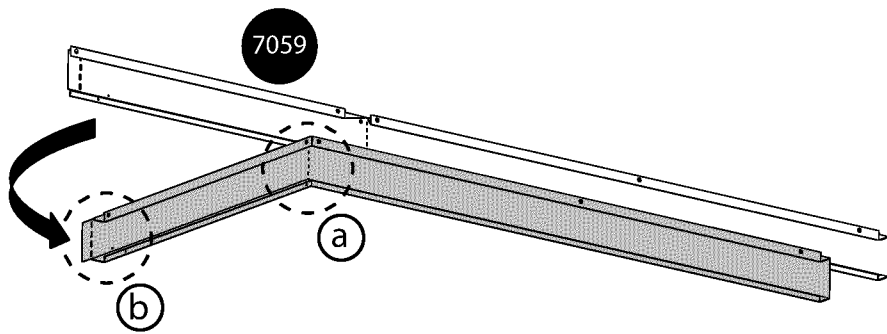
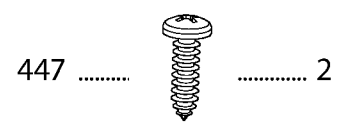
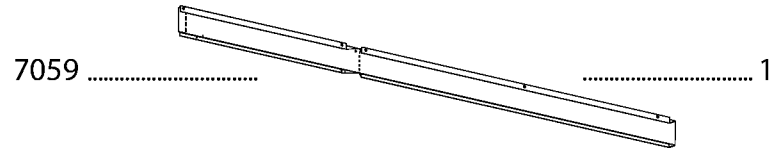
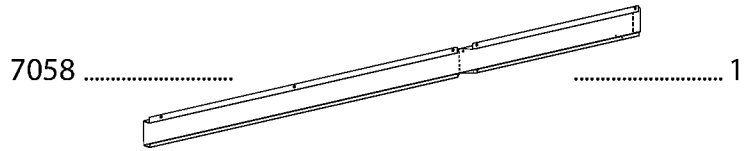
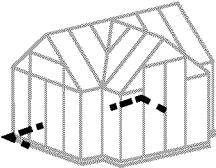

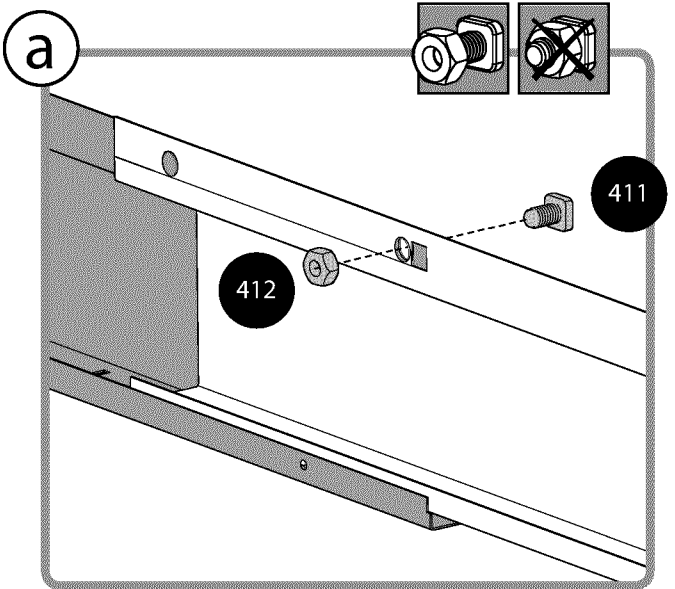
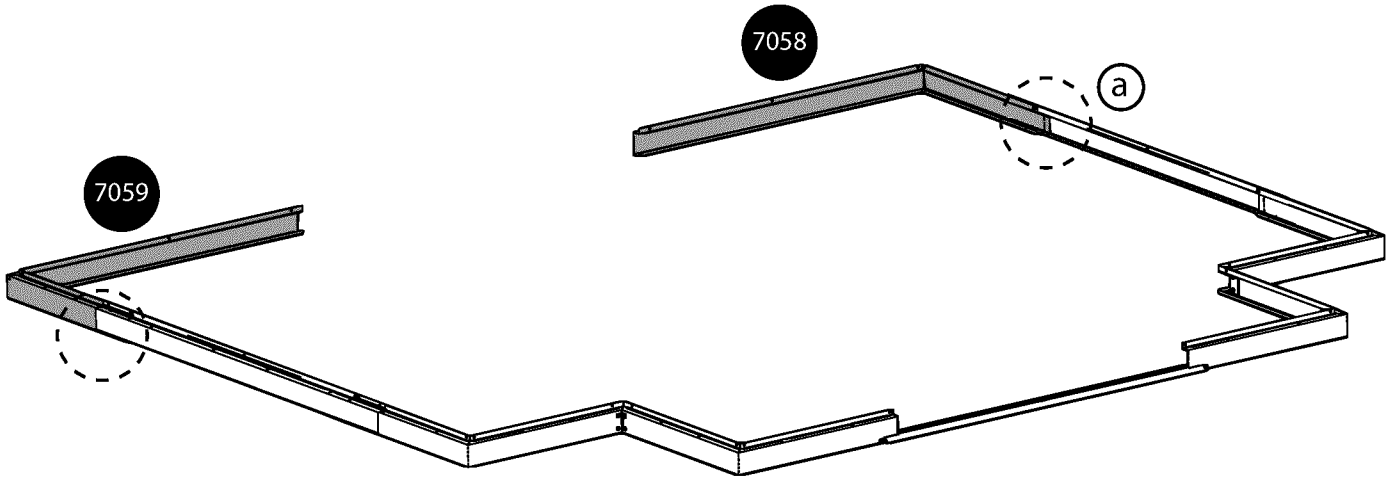
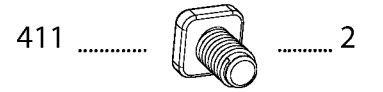
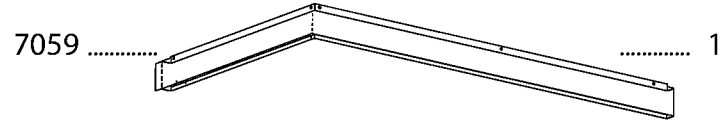
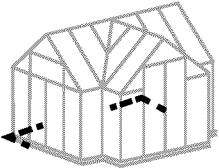

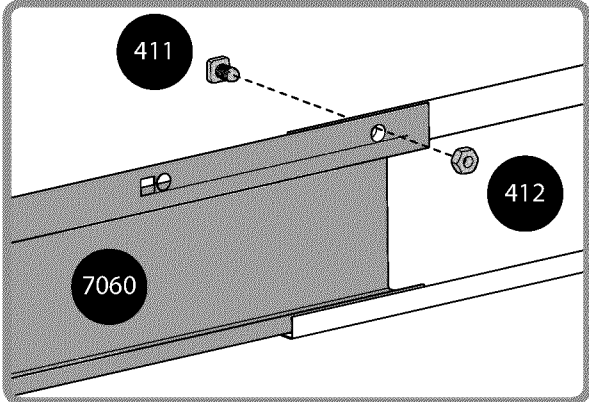
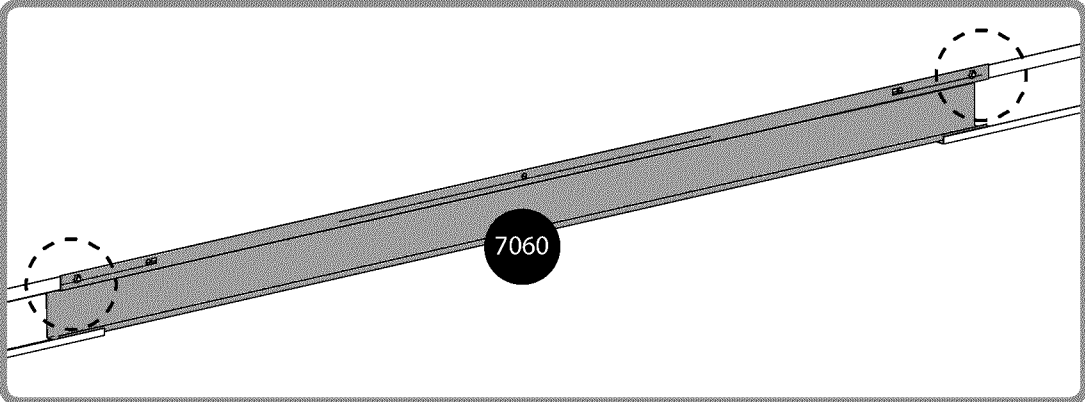
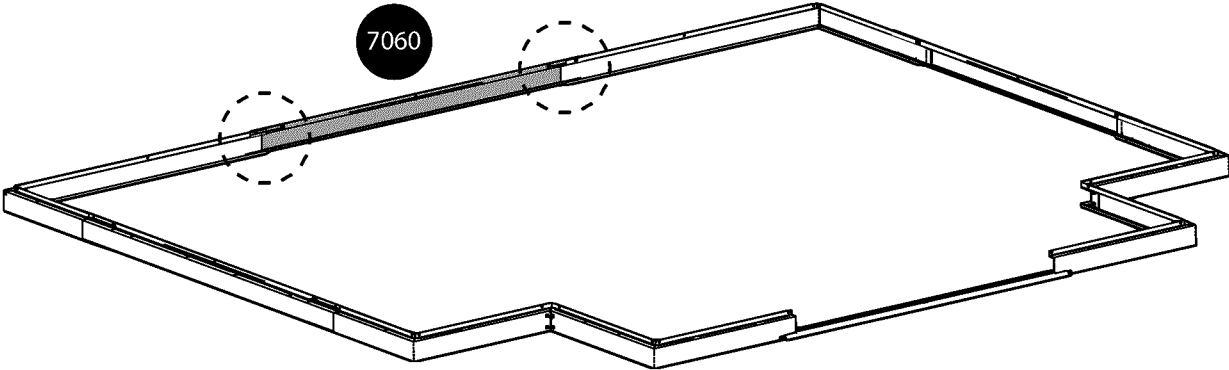
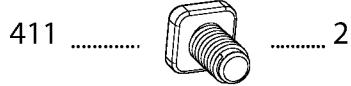
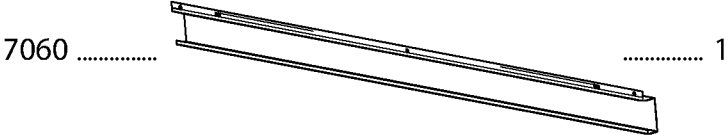
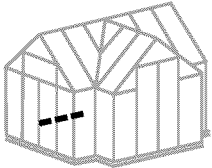

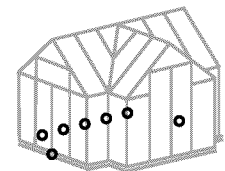

411  4

412  4

466  5

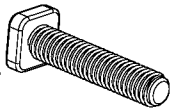
7284  5

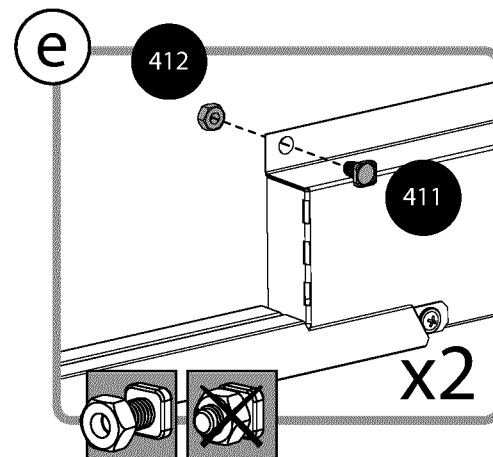
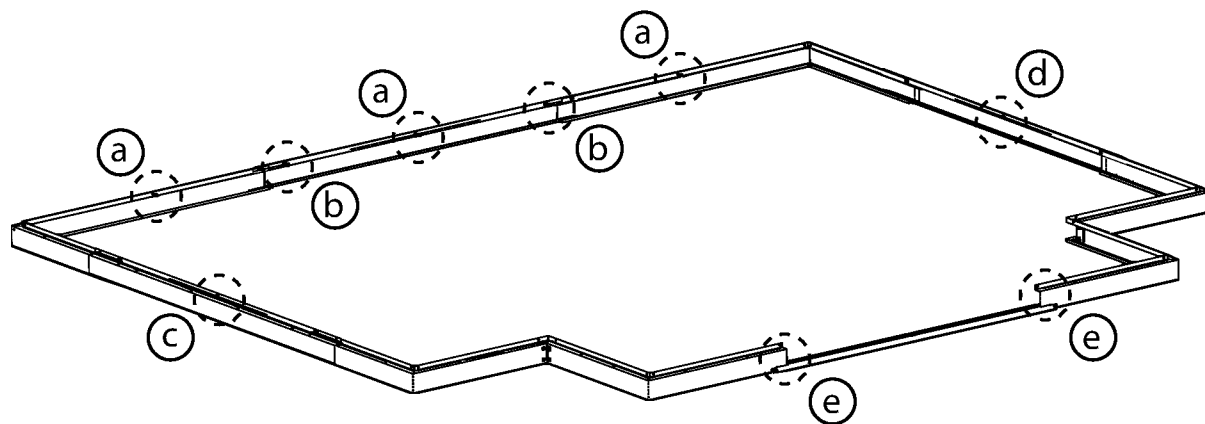
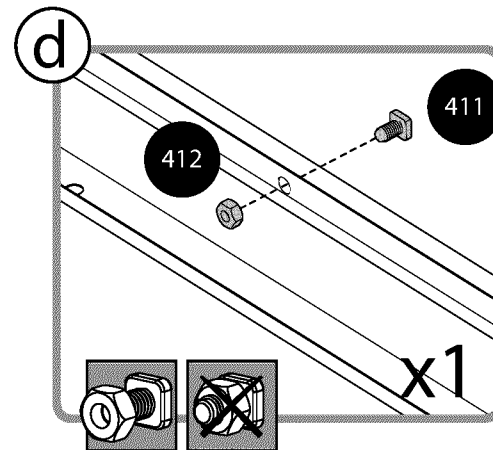
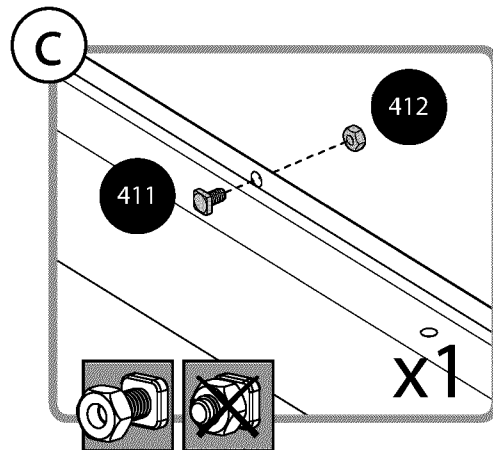
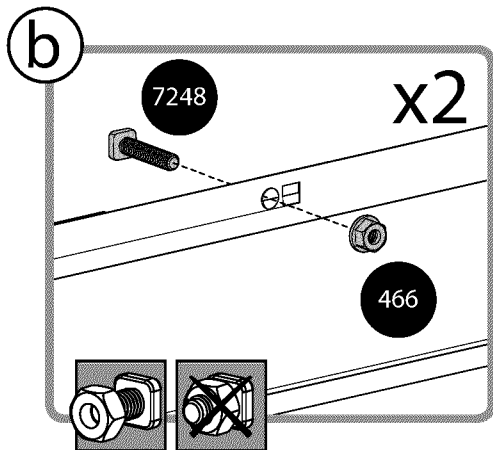
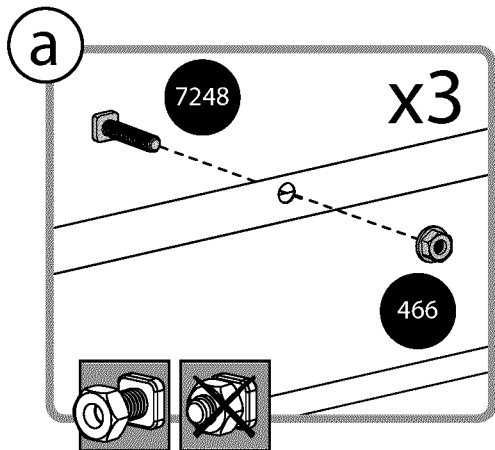

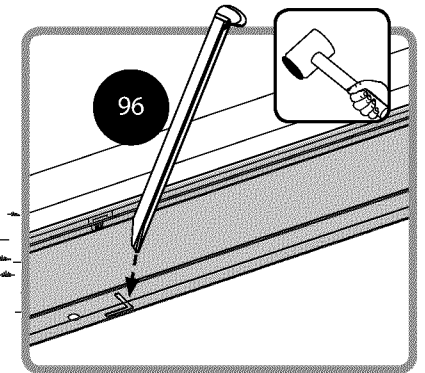
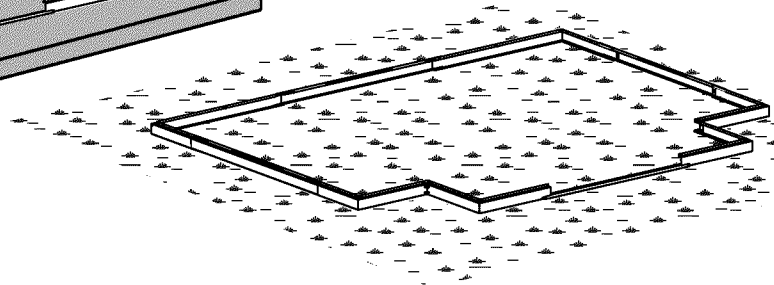
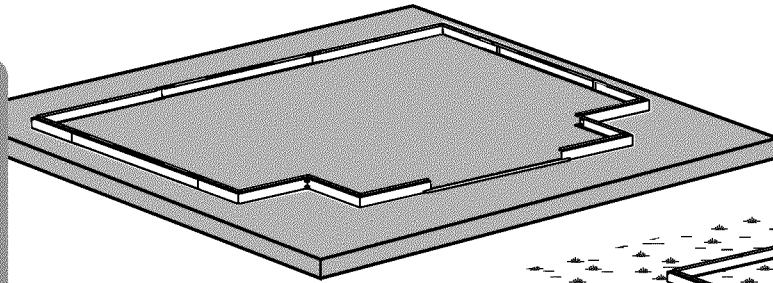
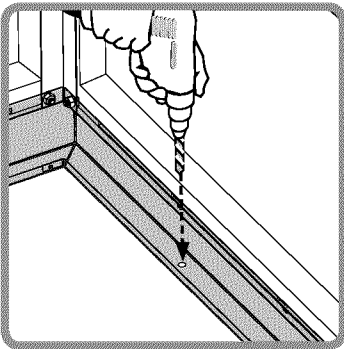
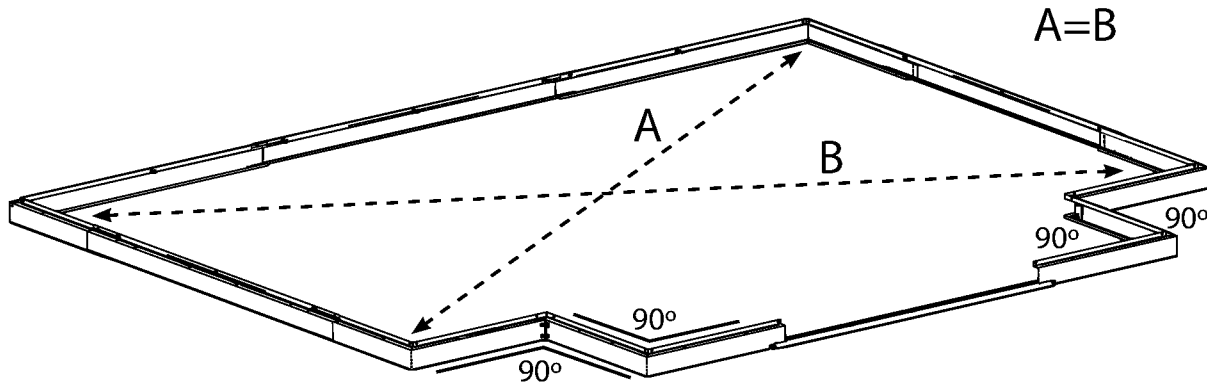
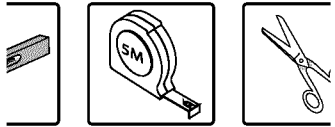
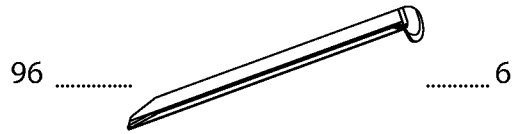
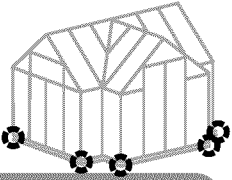

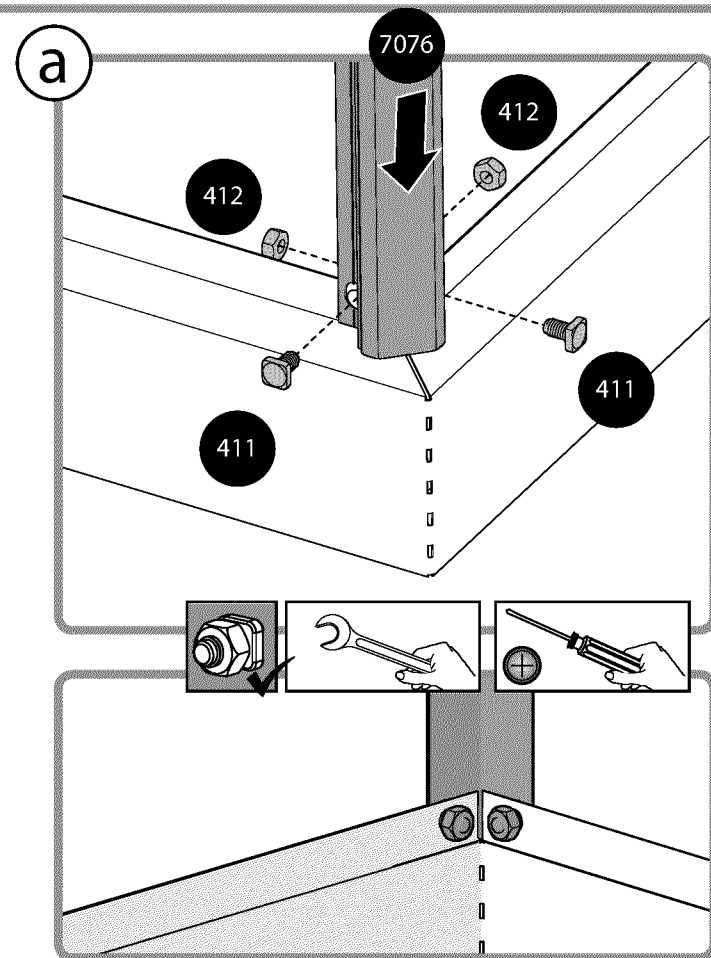
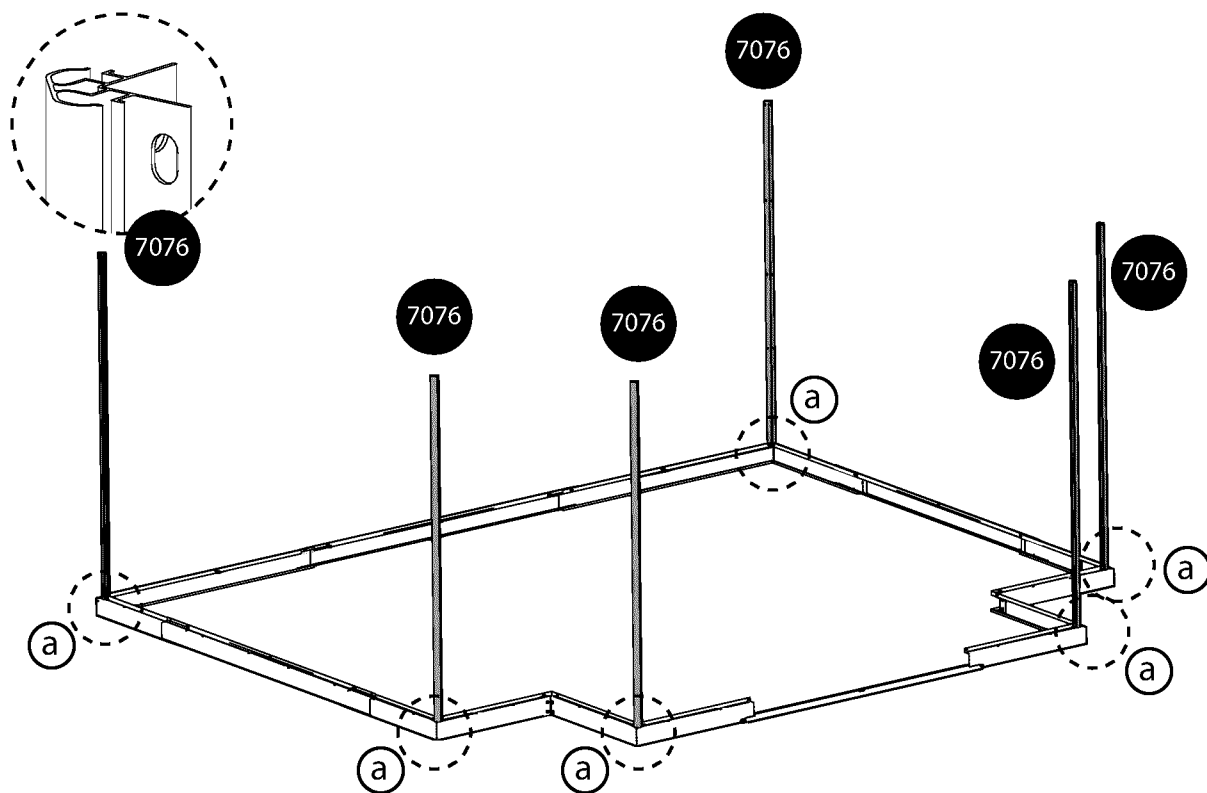
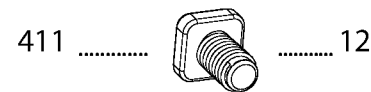
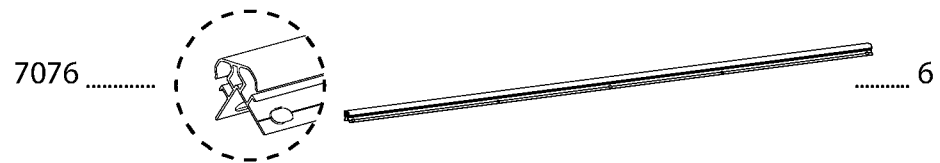
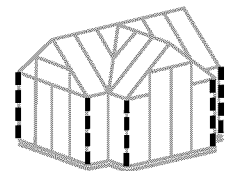

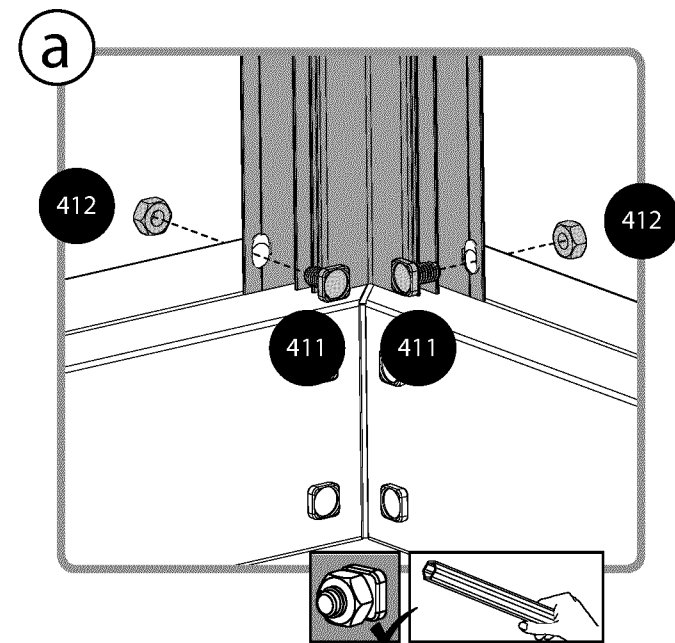
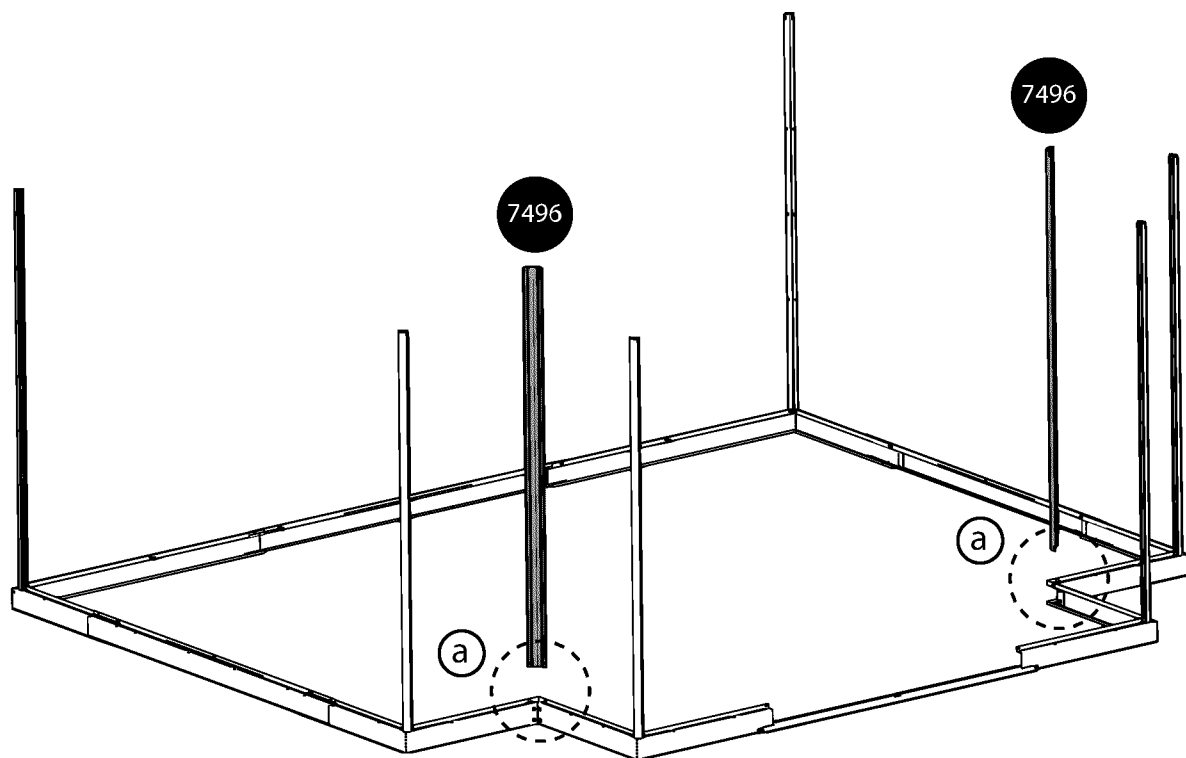
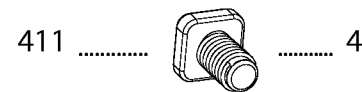
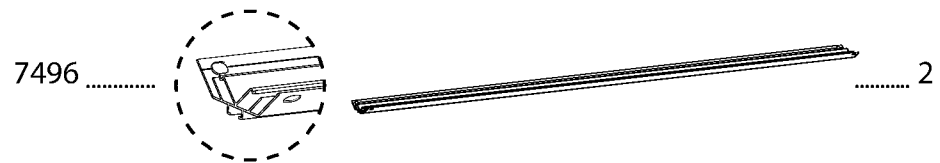
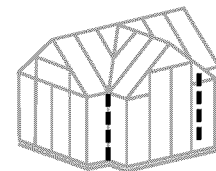

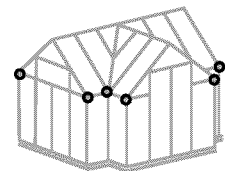



411  16

412  16

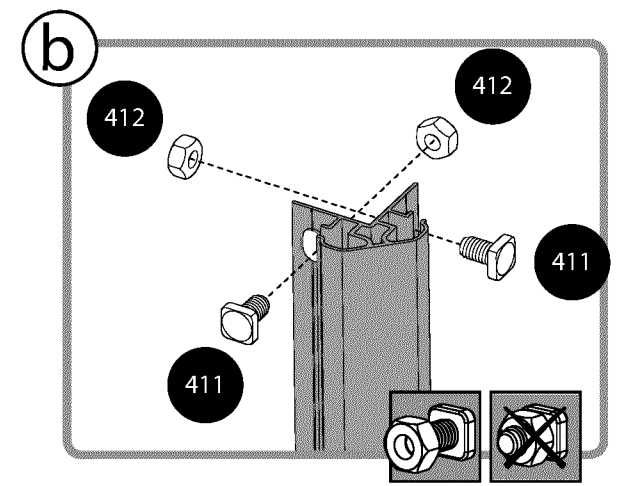
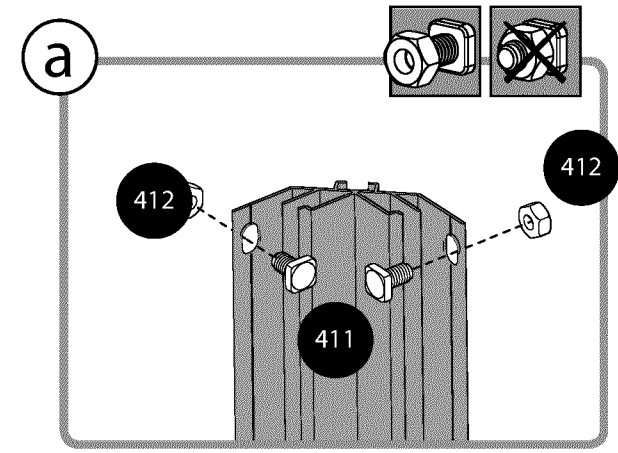
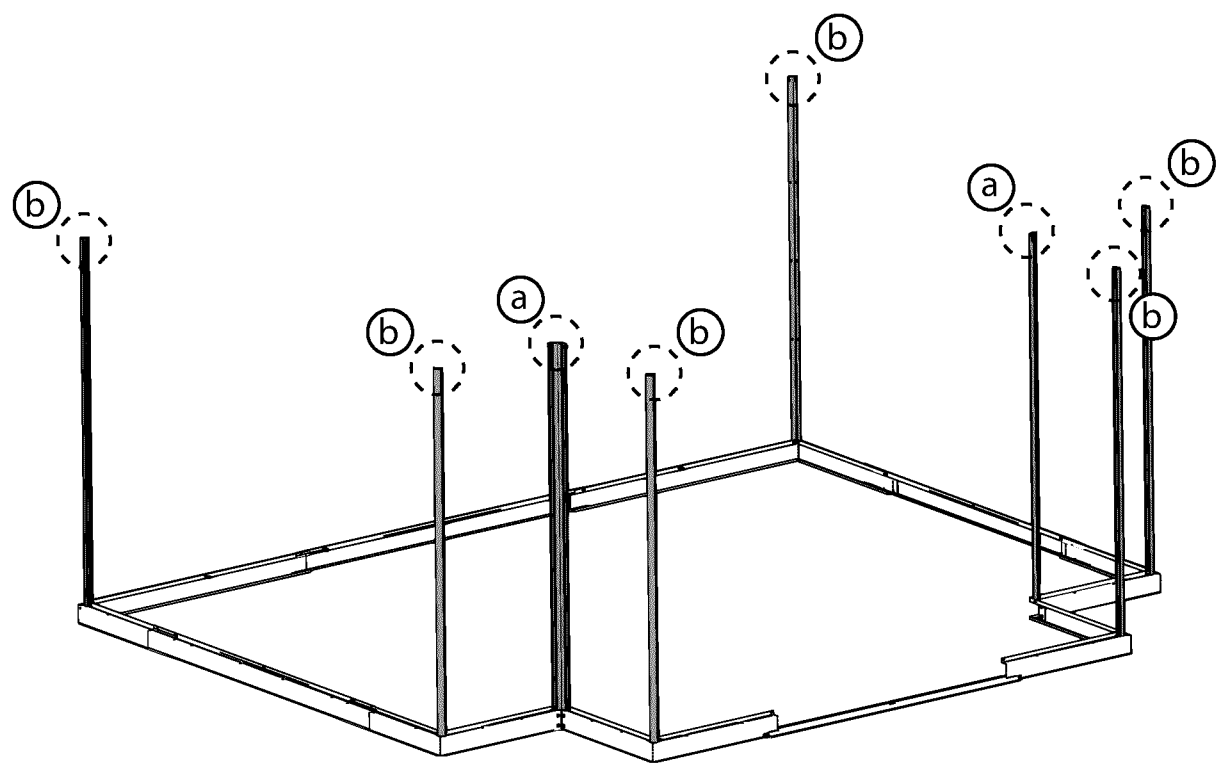

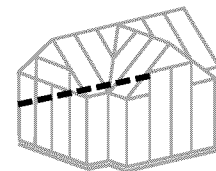

7180 2

411 2

412 2

7180

7180

411

412

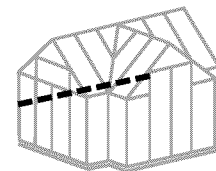

411  2 412  2

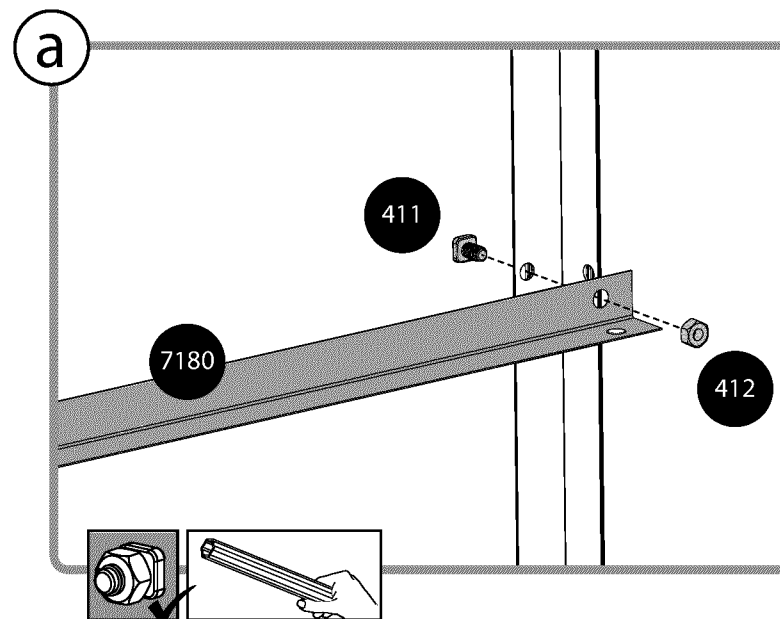
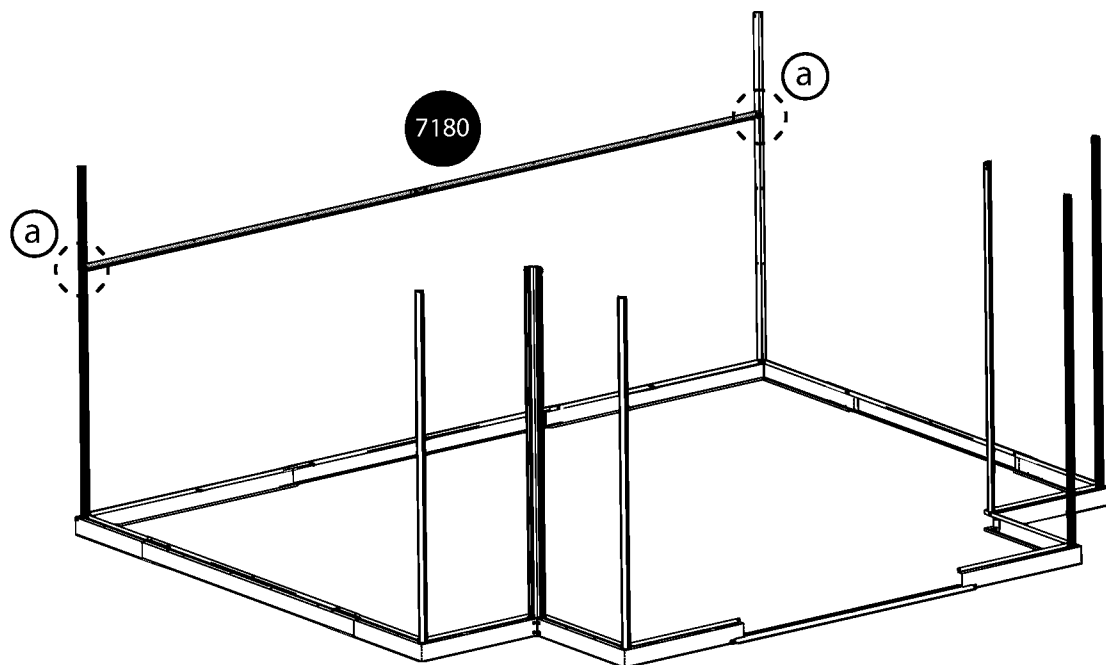

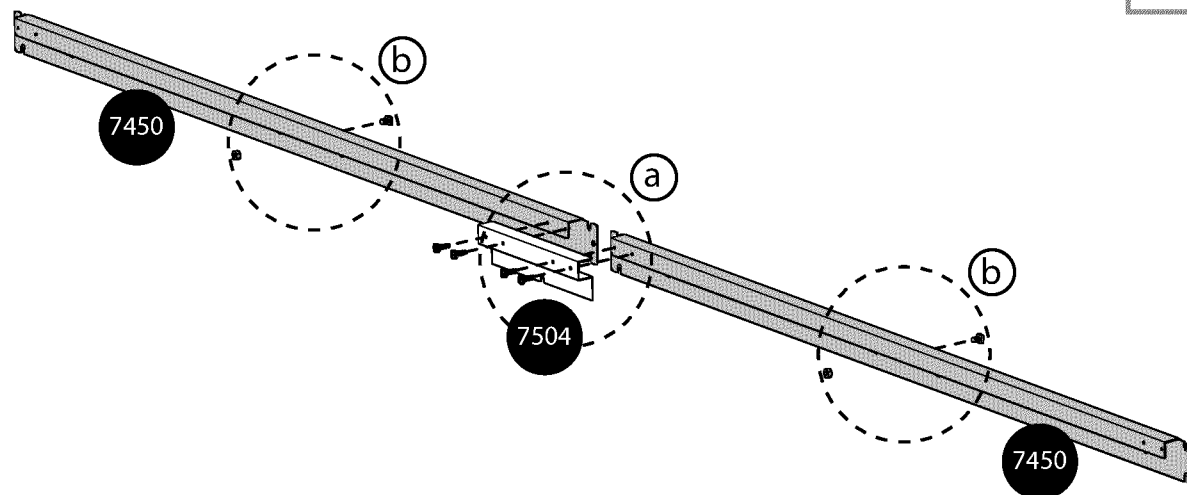
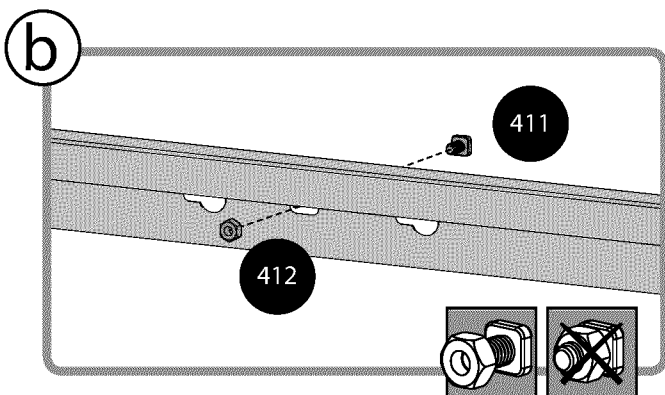
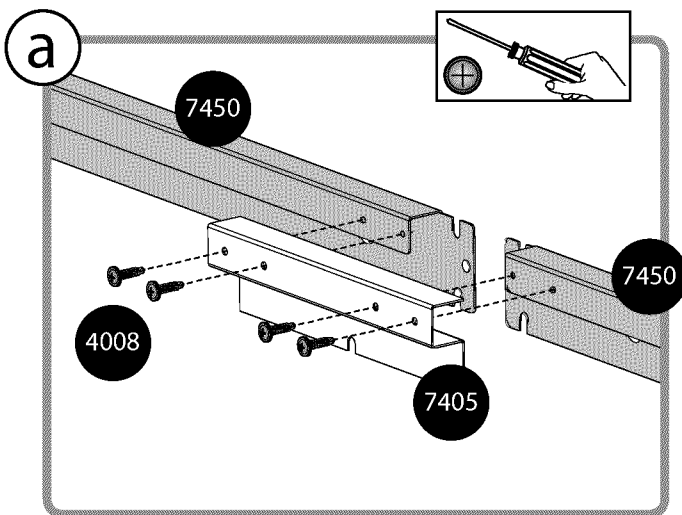
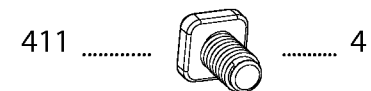
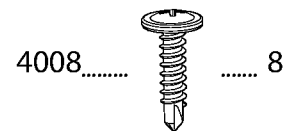
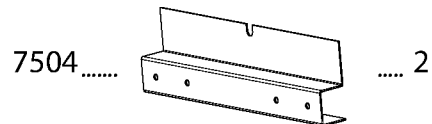
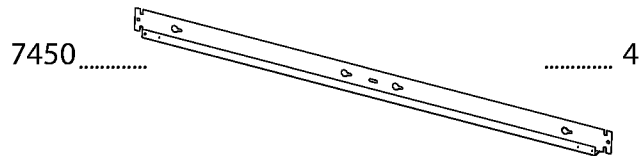
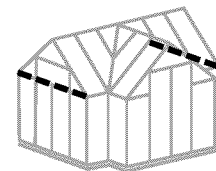

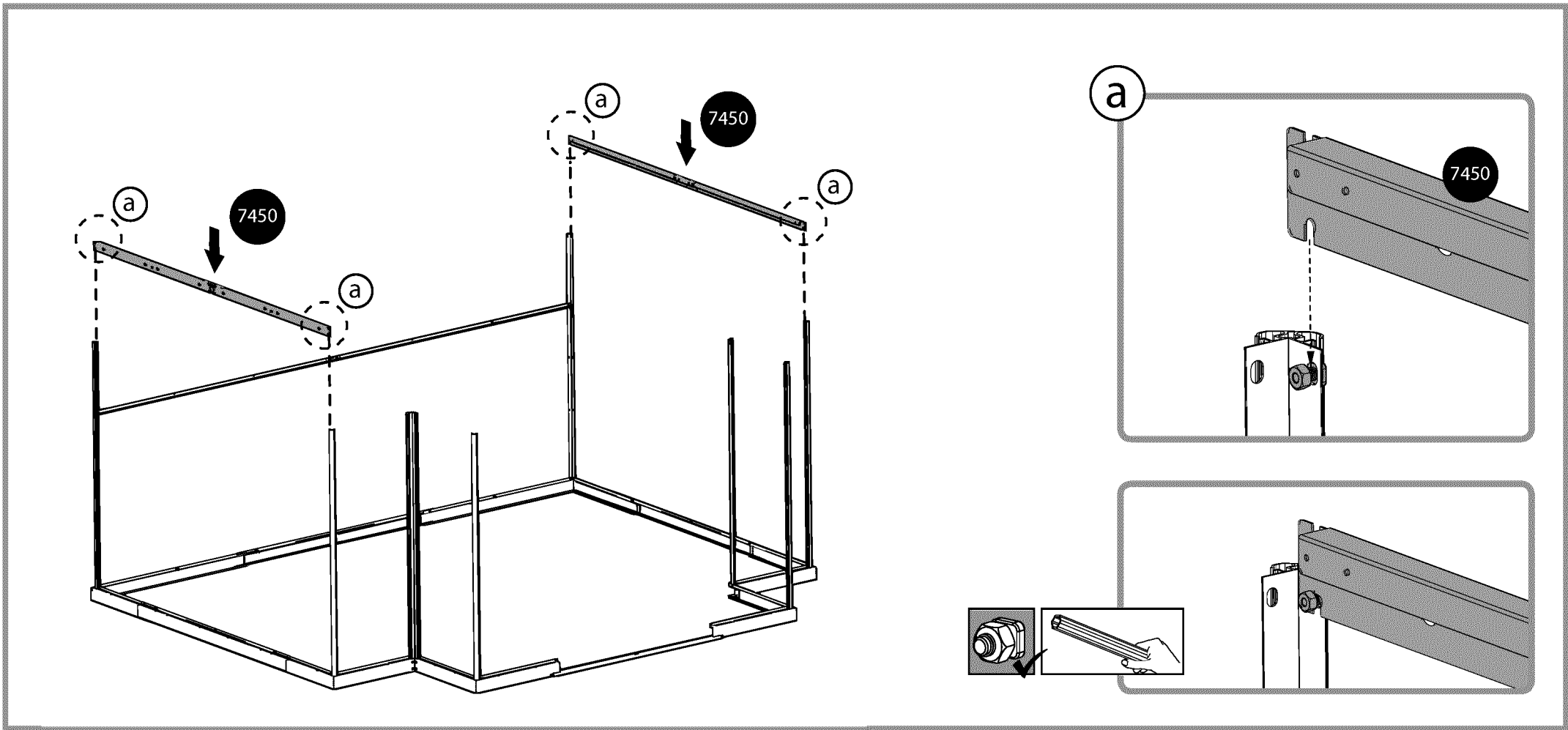
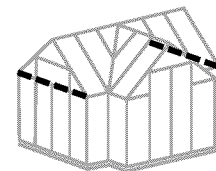

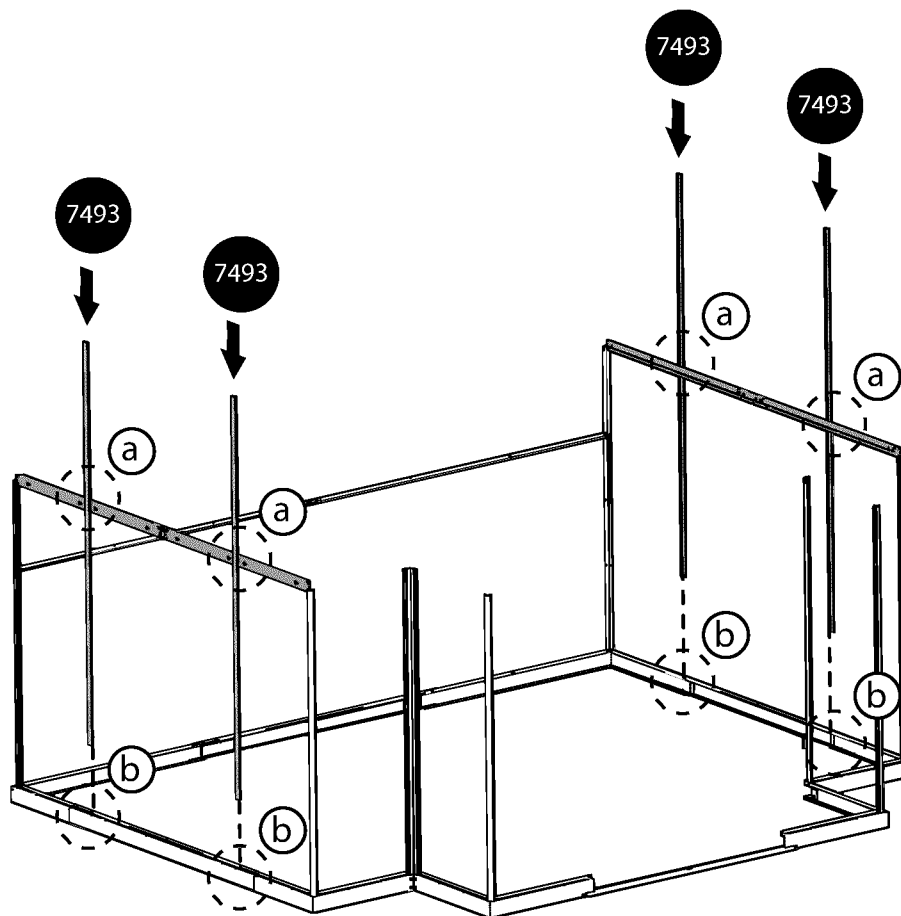
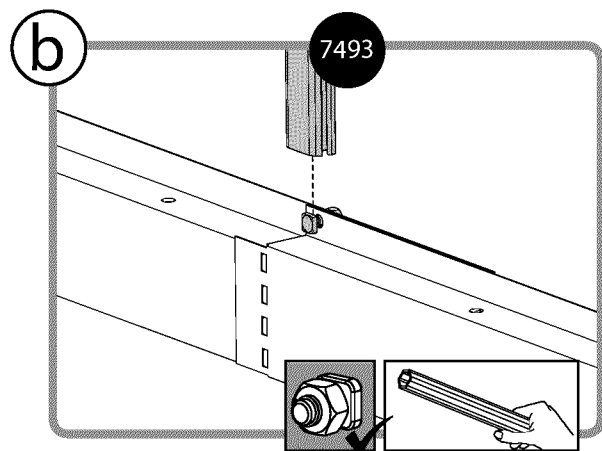
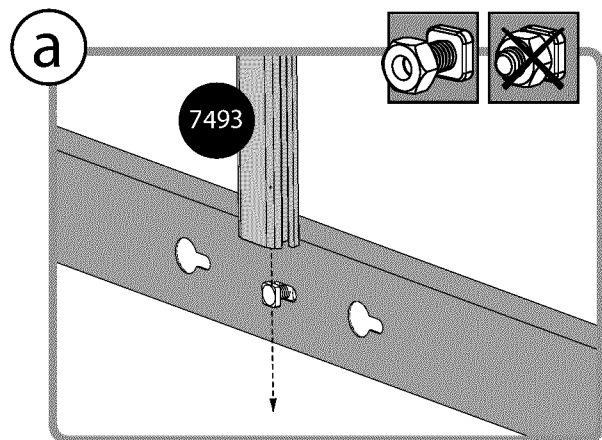
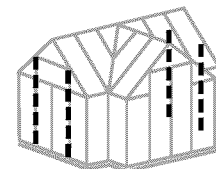

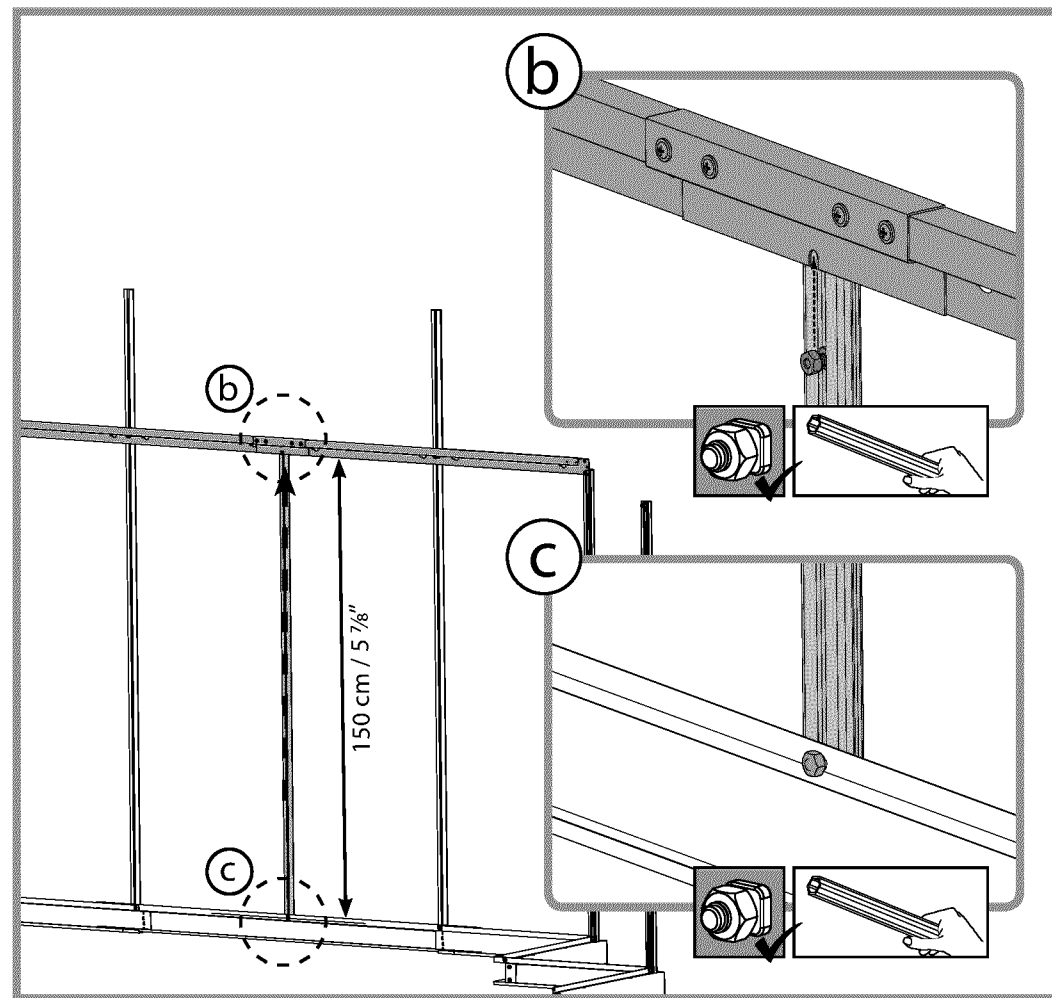
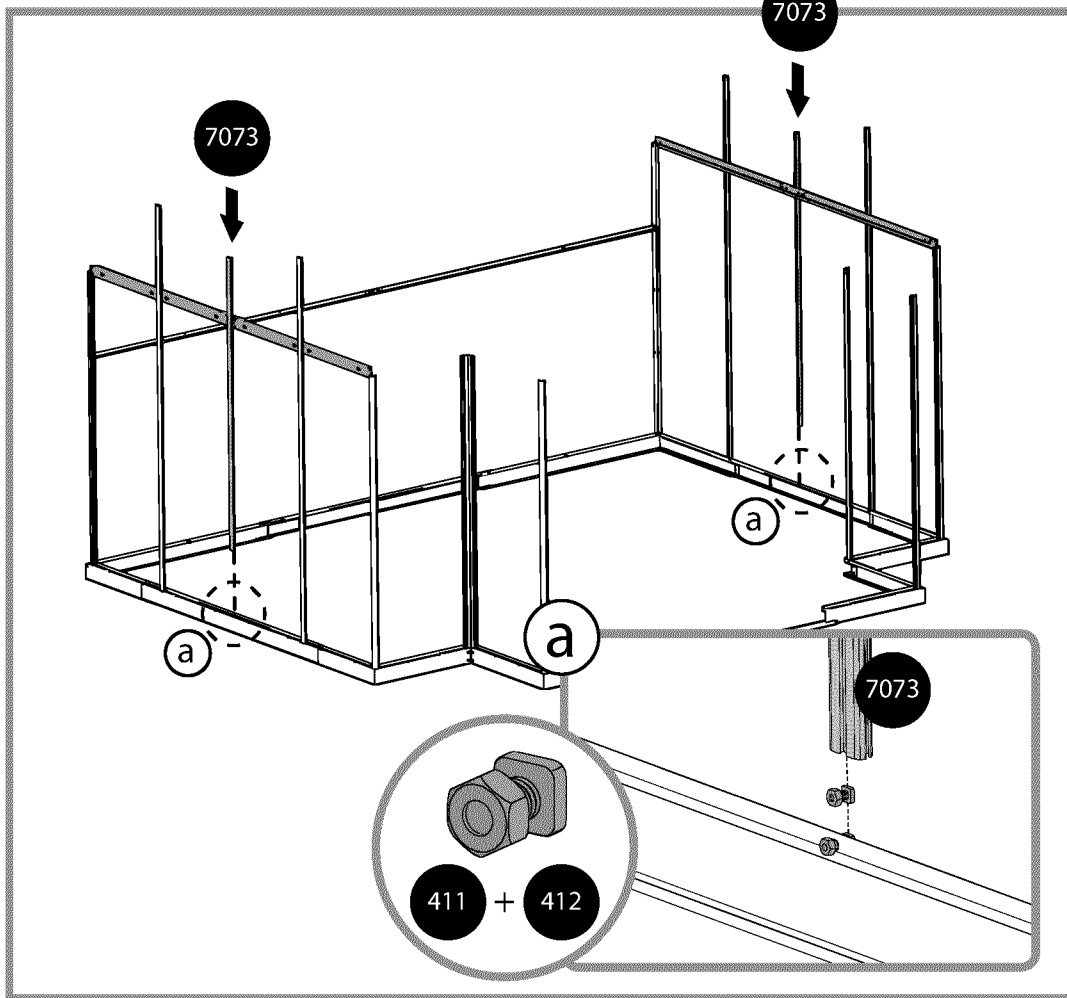
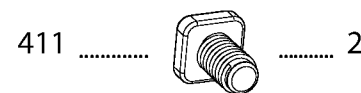
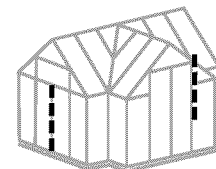

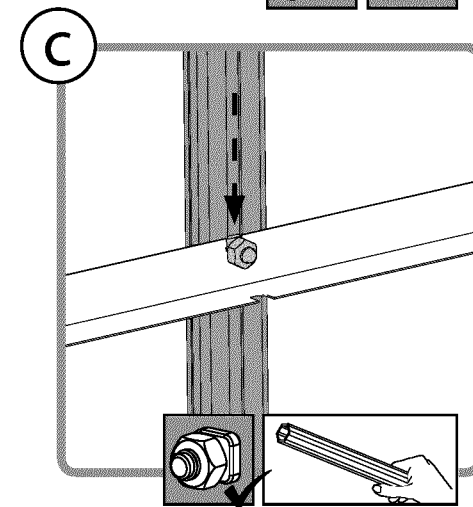
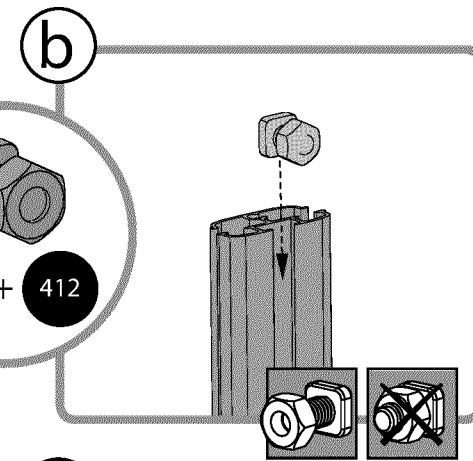
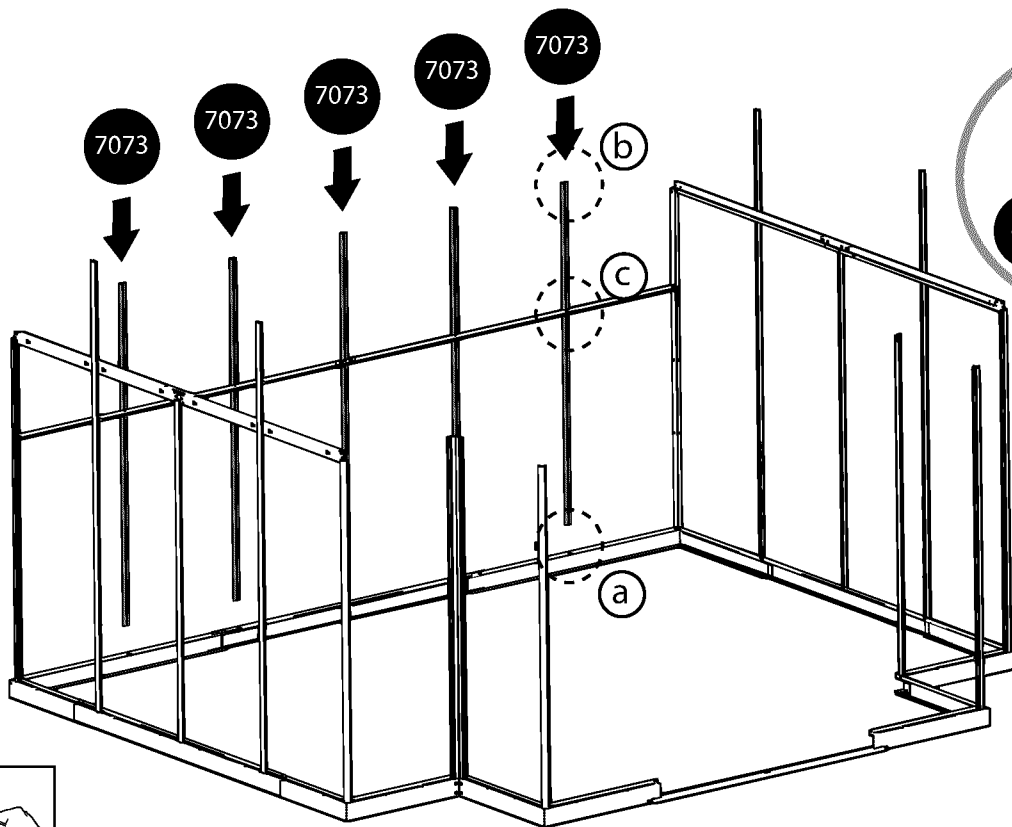
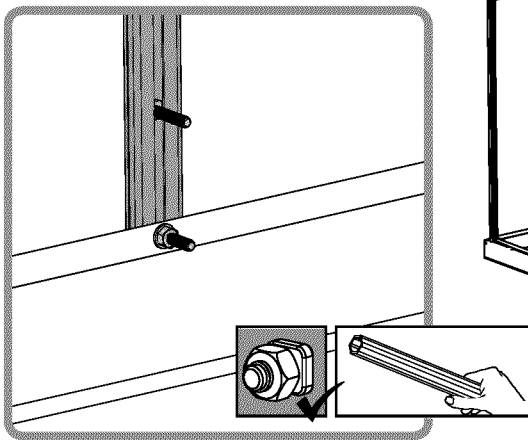
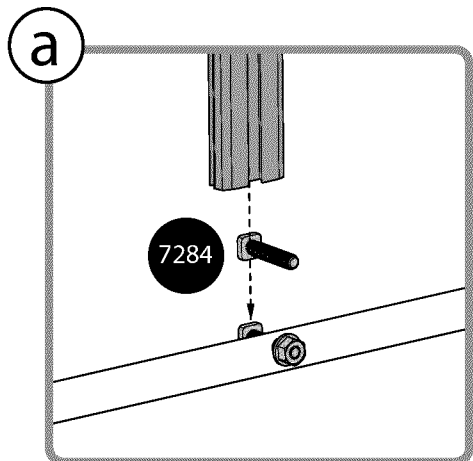
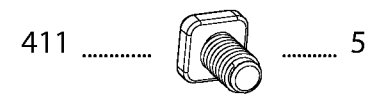
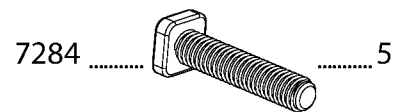
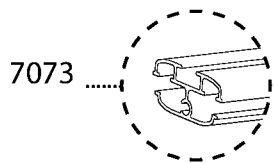
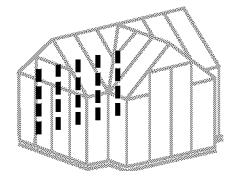

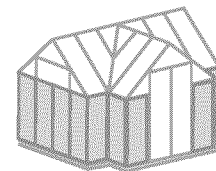

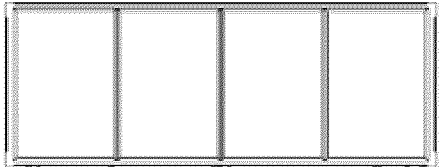
566  20

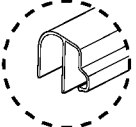
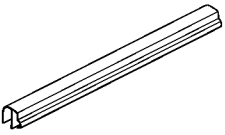
318   20

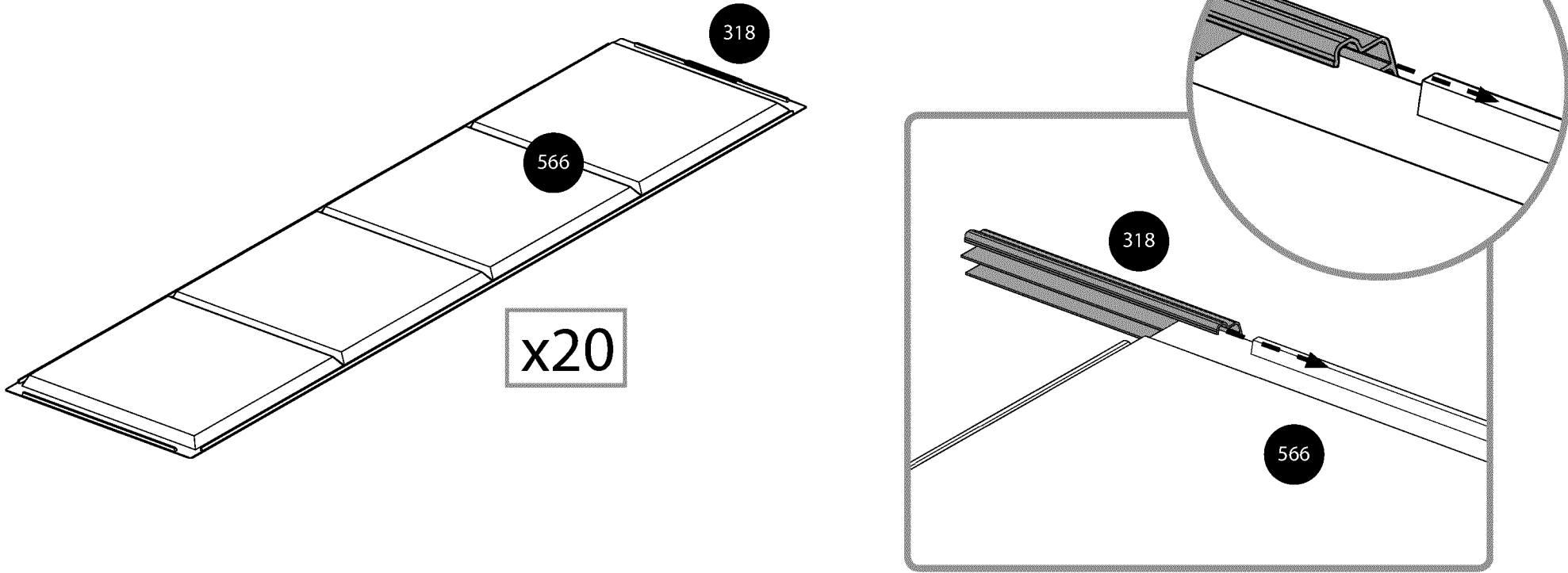

318

566

x20

318

566

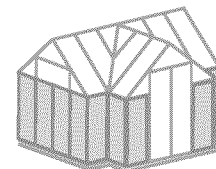

566+318

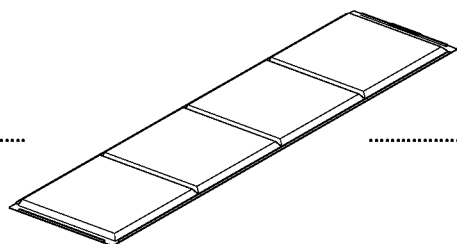

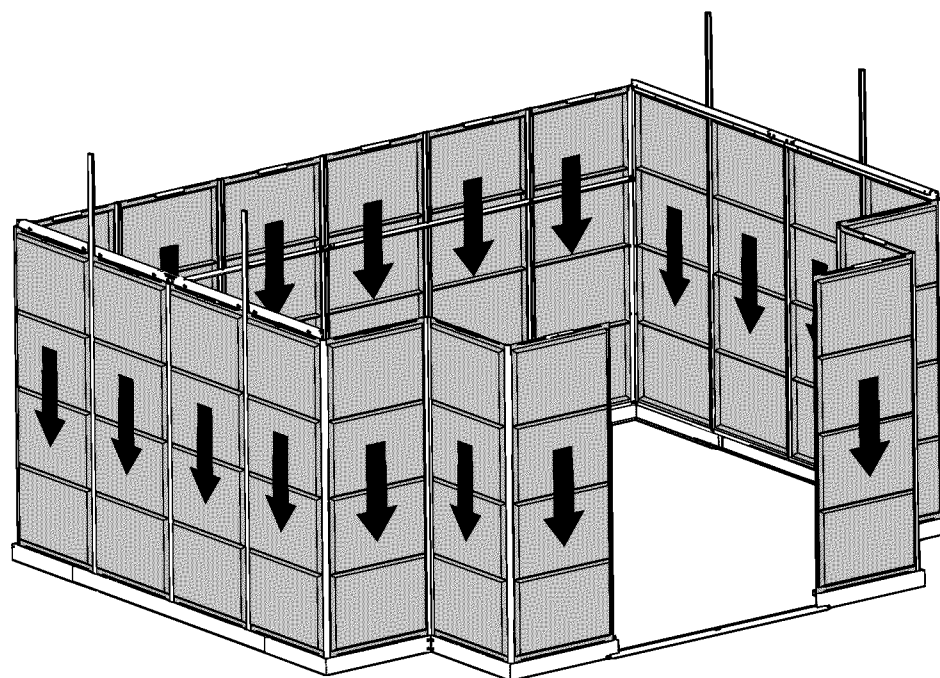
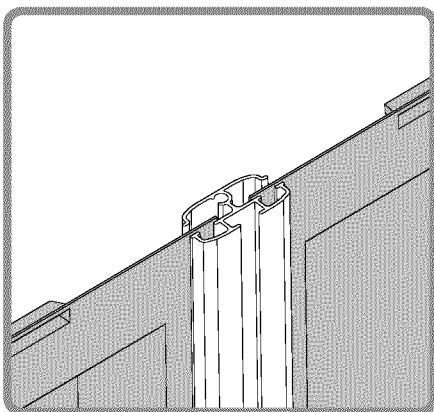
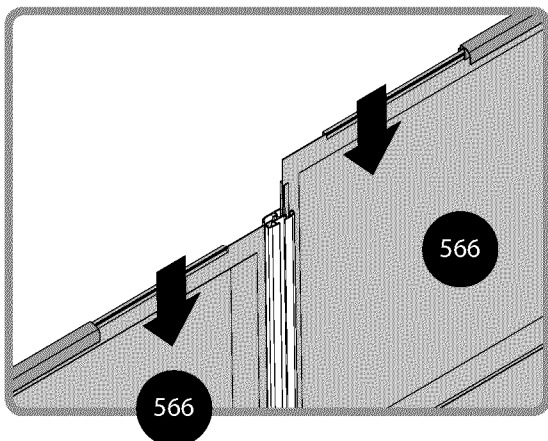
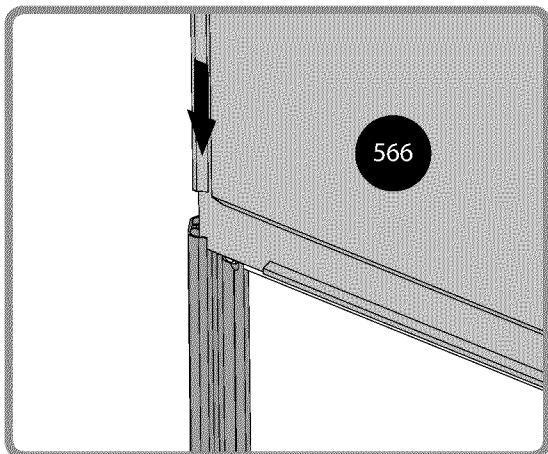

.....20

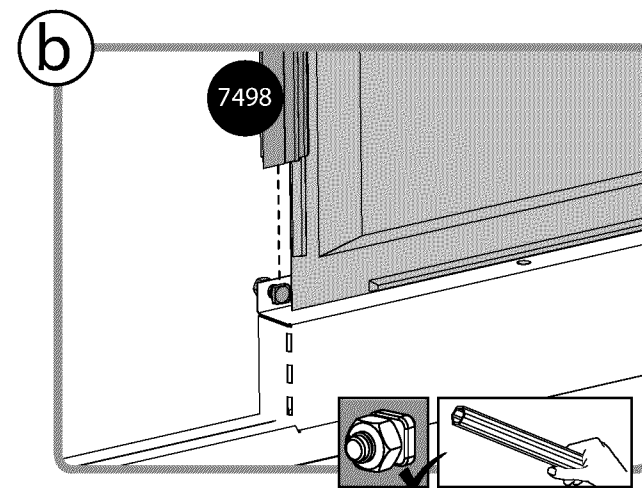
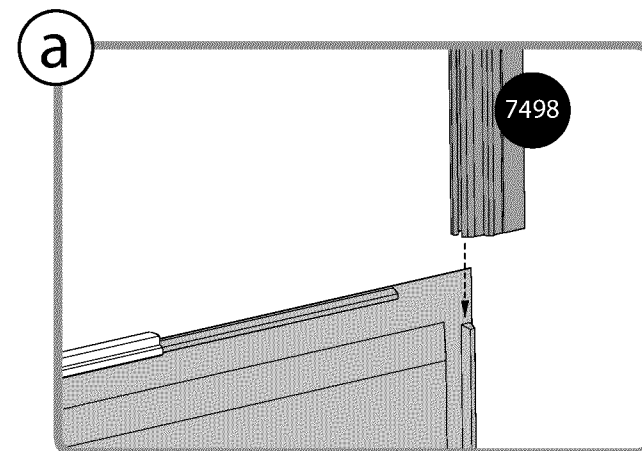
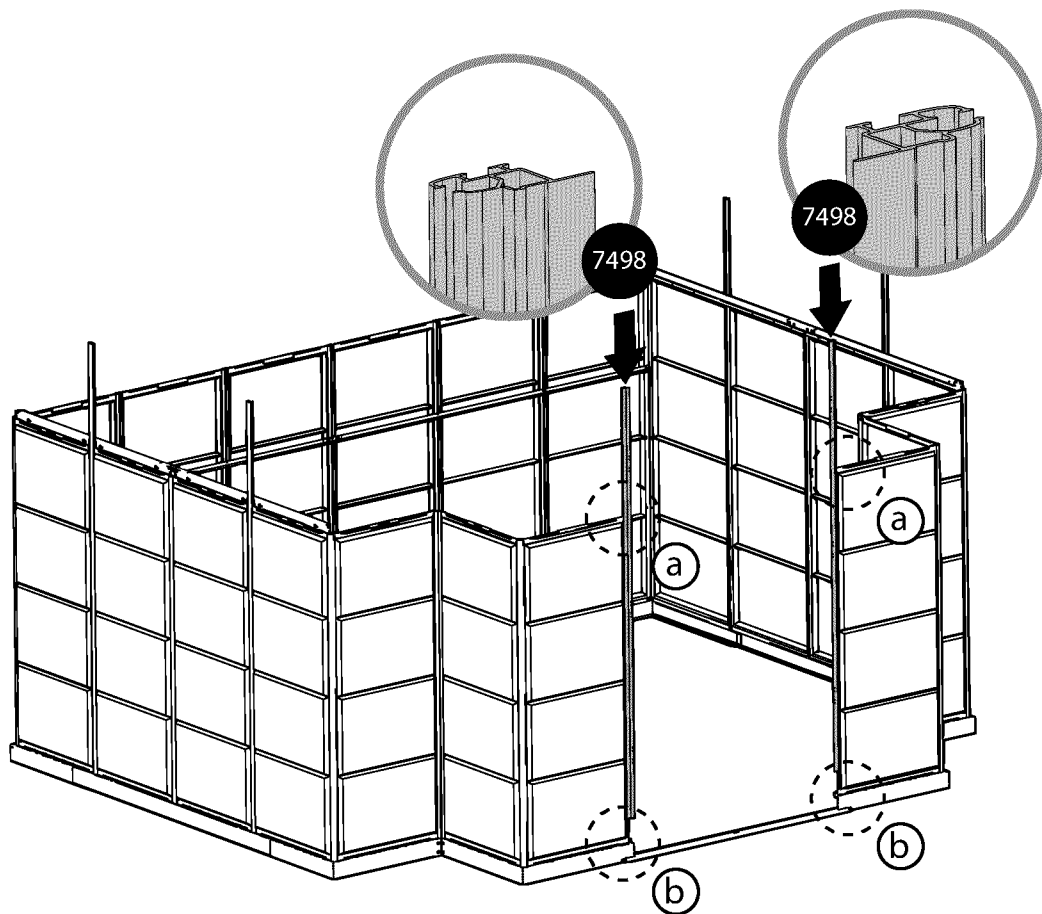
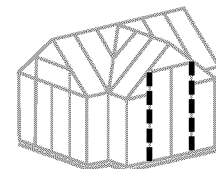

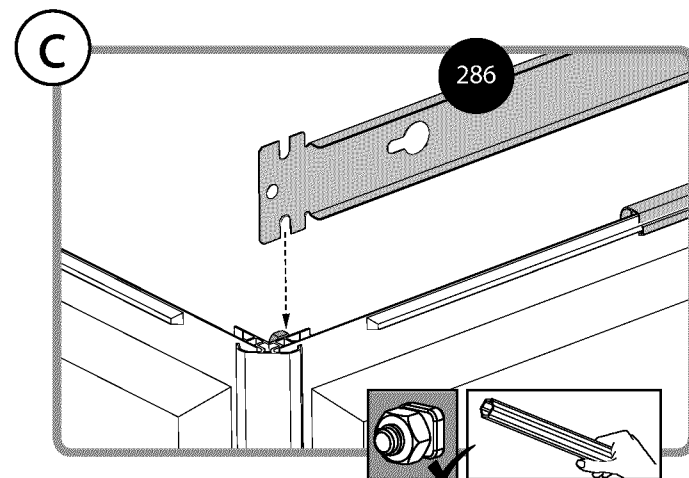
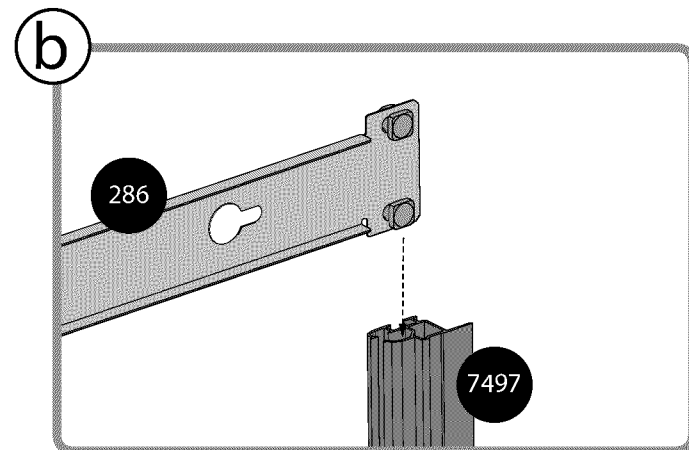
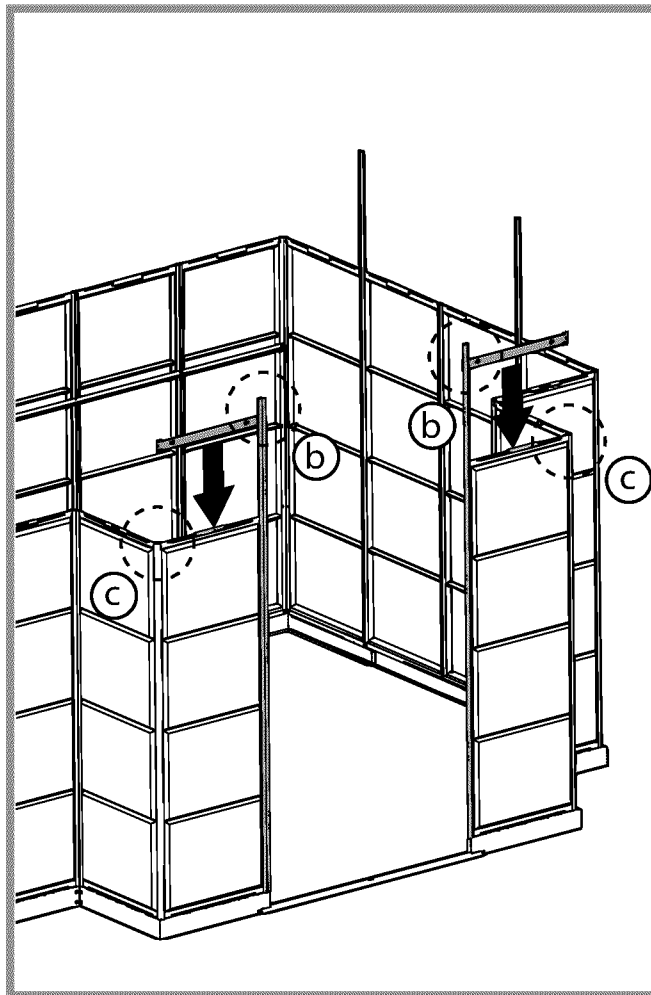
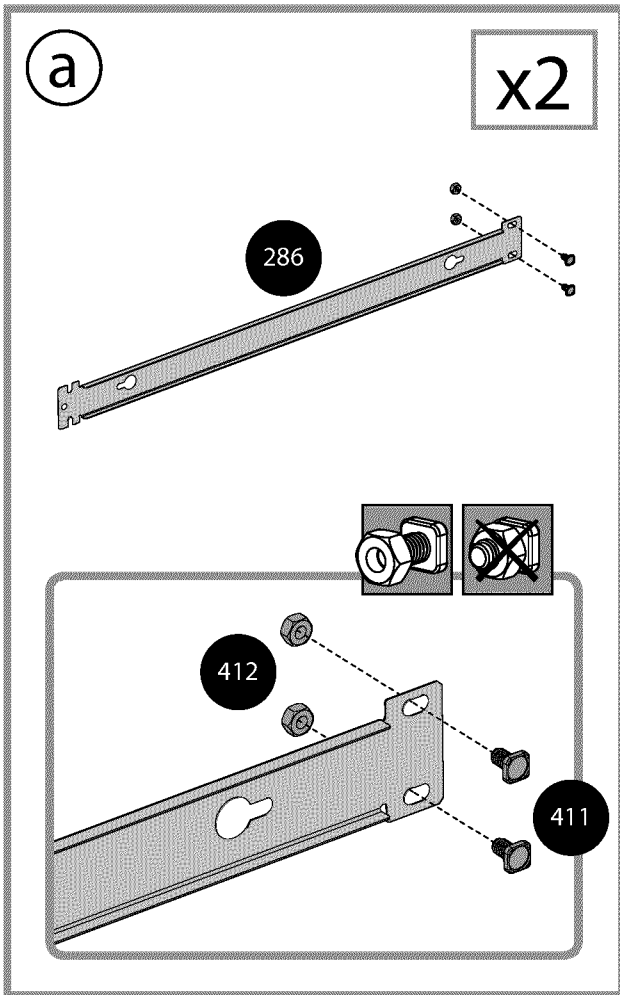
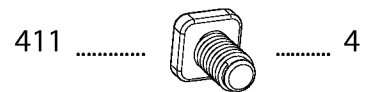
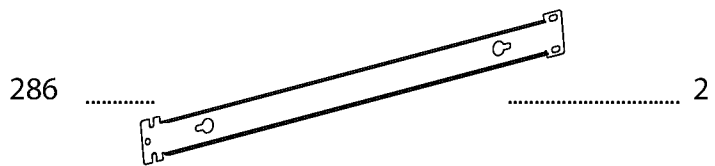
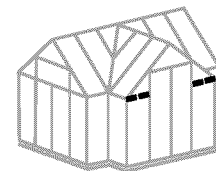

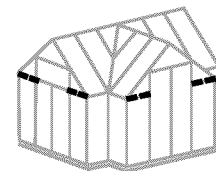

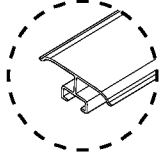

- 999  6
- 411  12
- 412  12

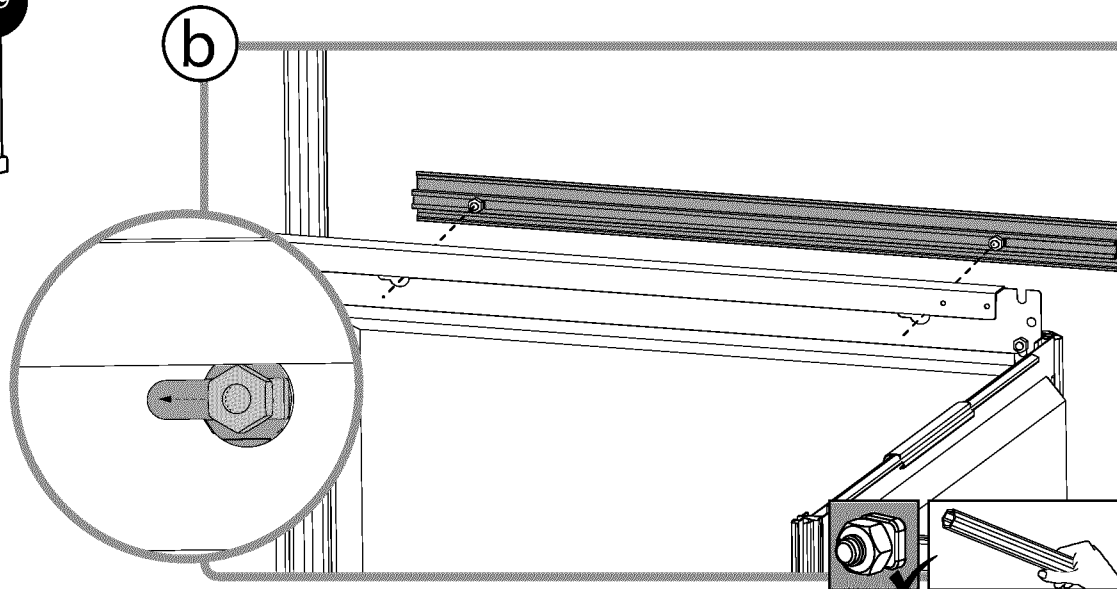
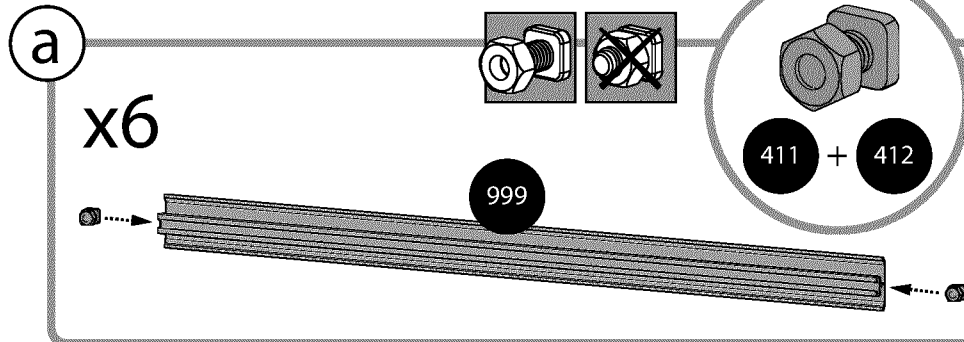
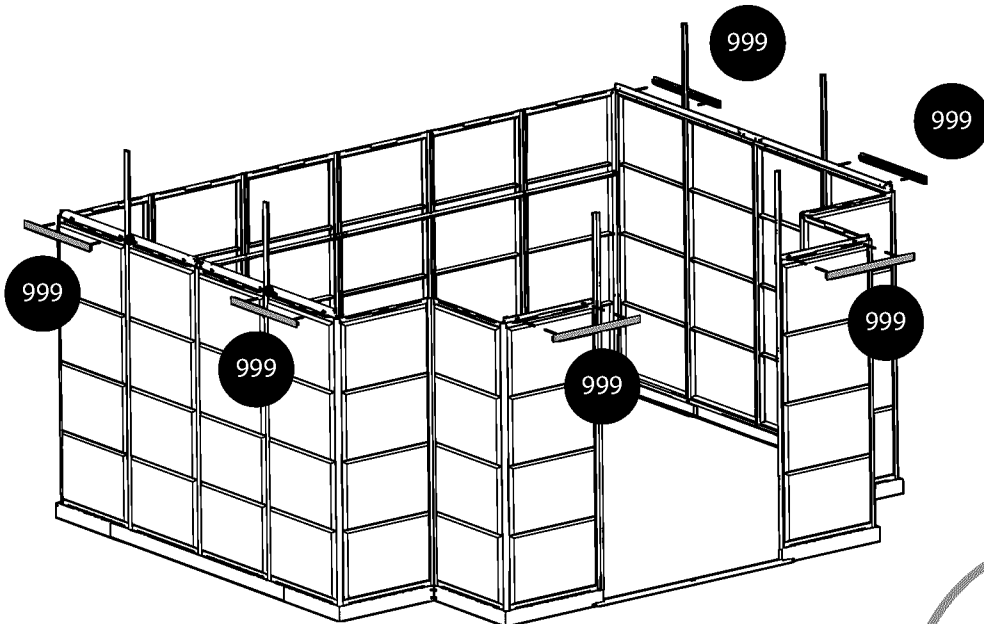

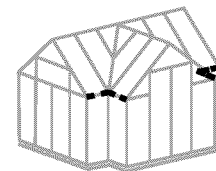

7499

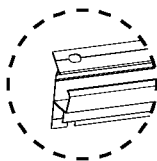

4

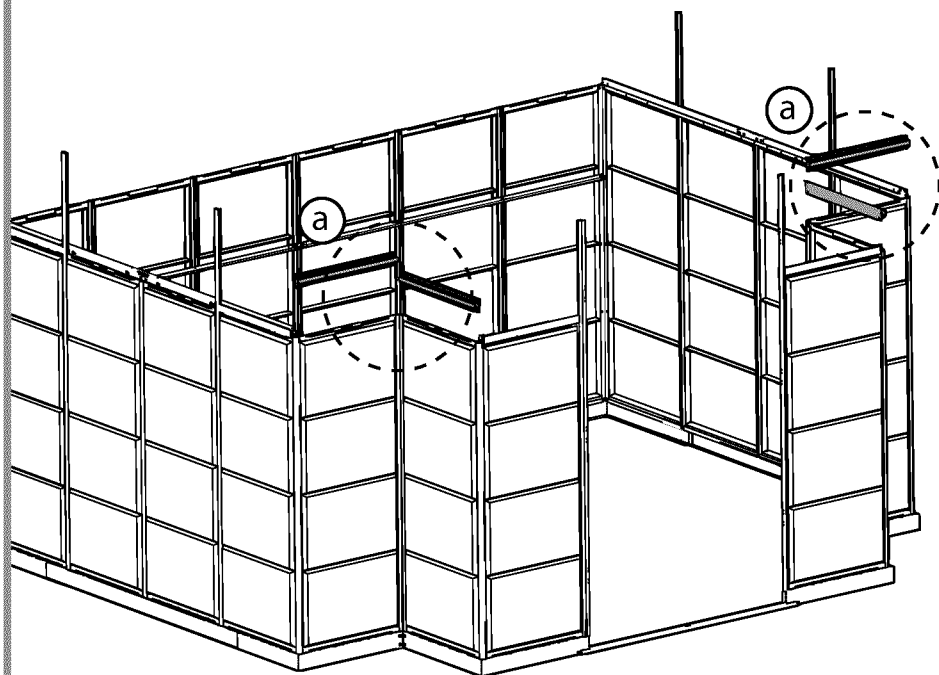

a

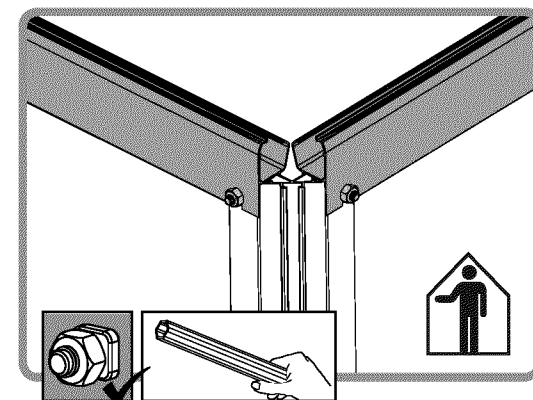
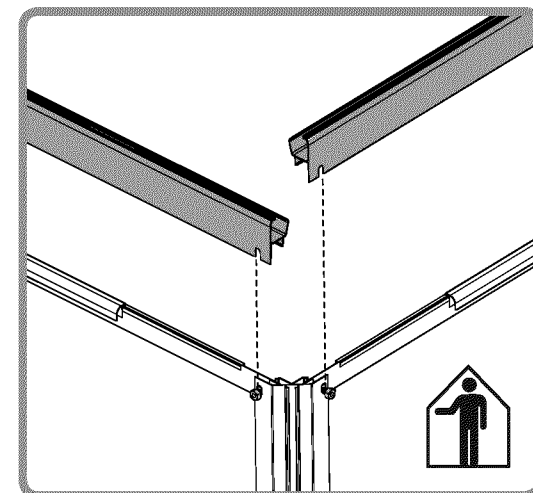
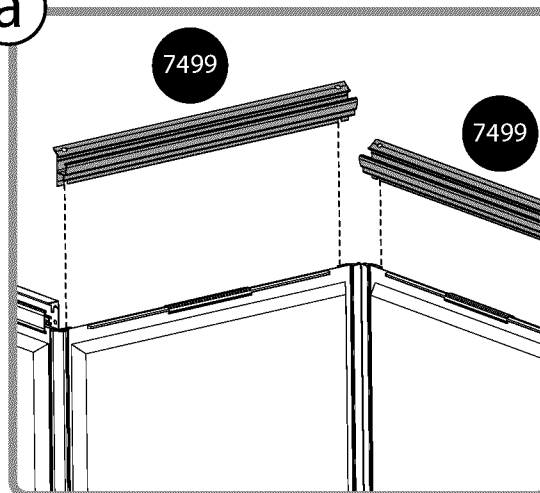

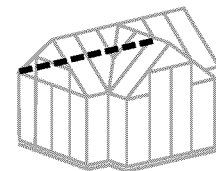

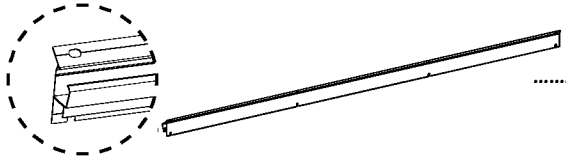

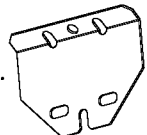
972  2

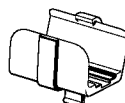
08  1

292  1

411  4

412  4

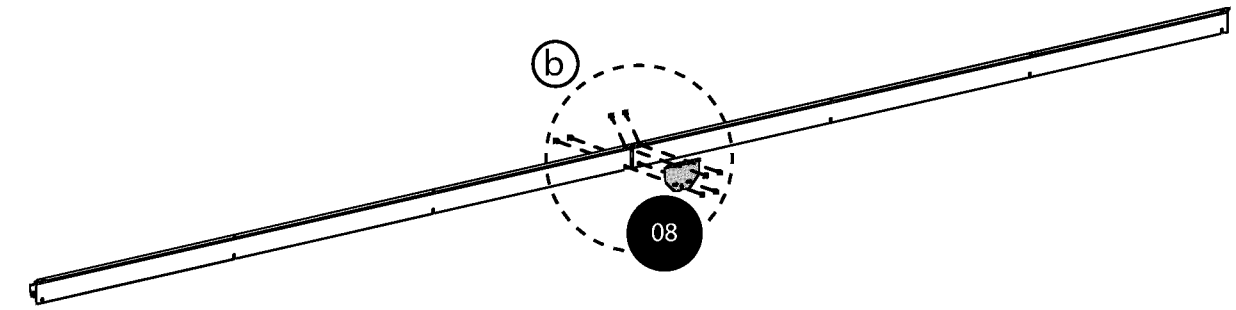
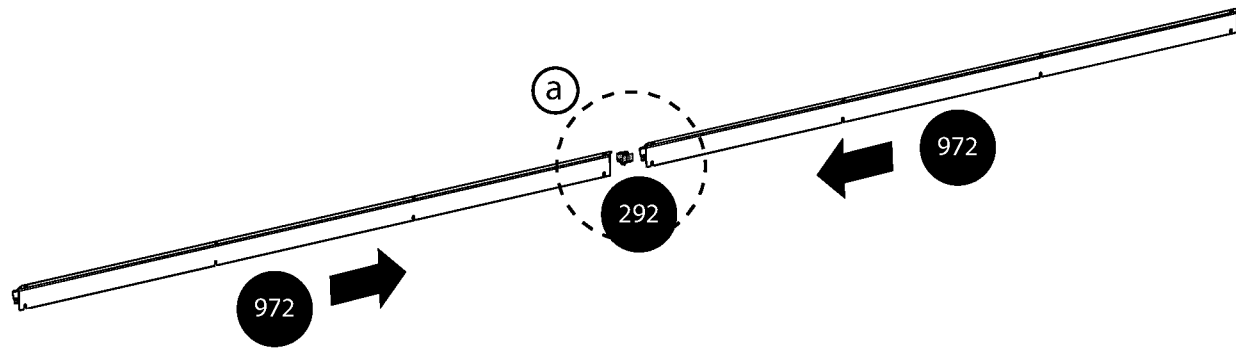
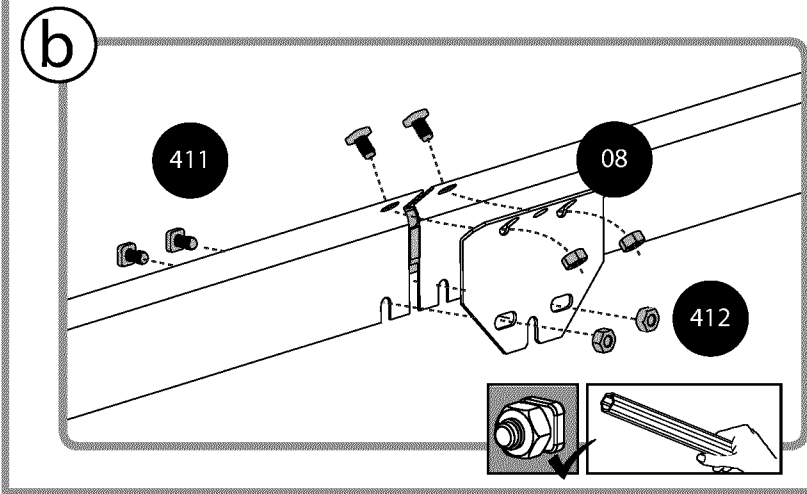
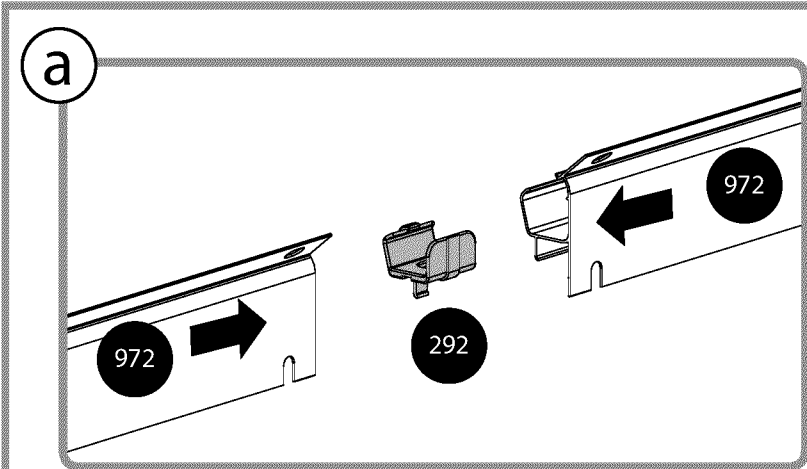

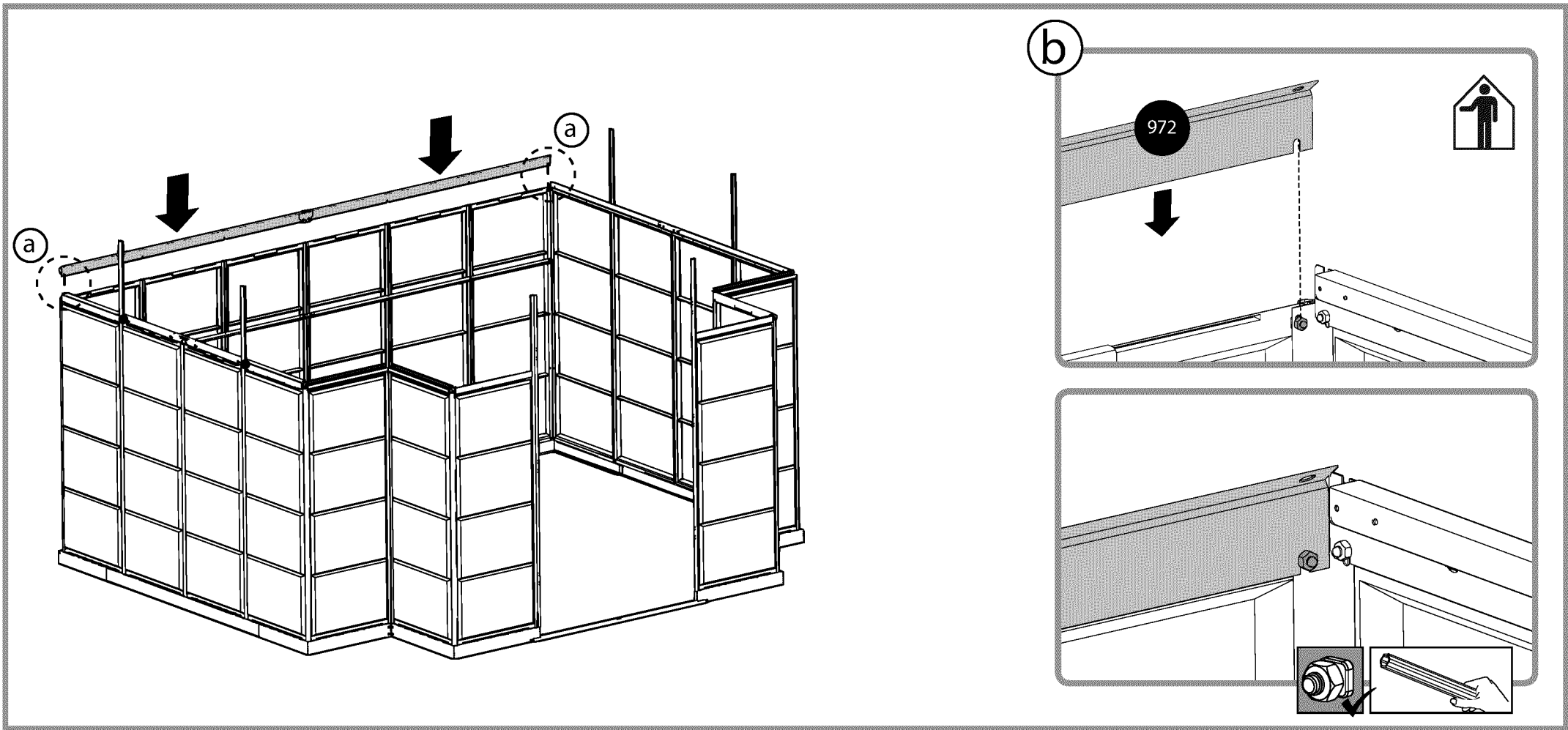
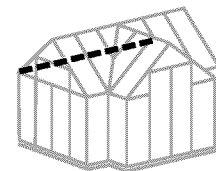

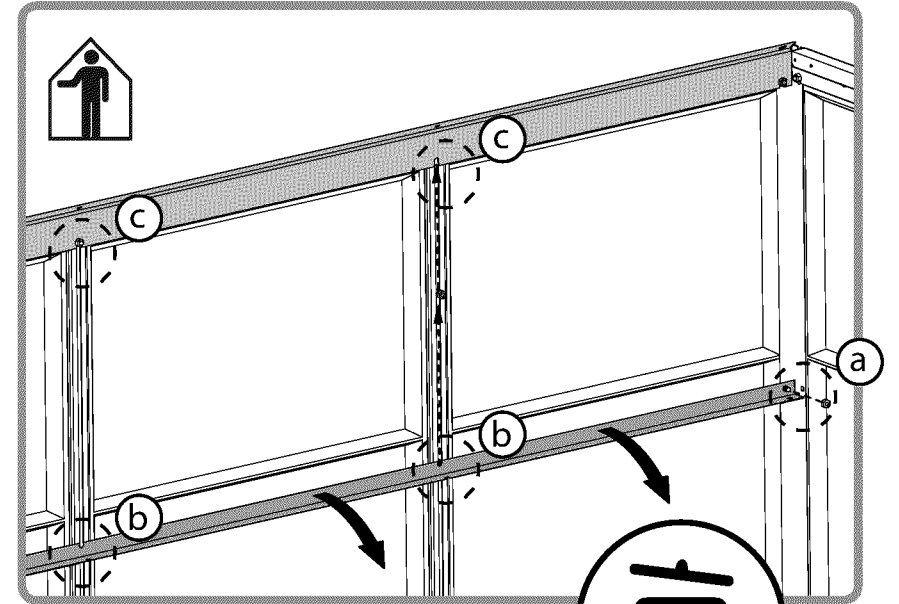
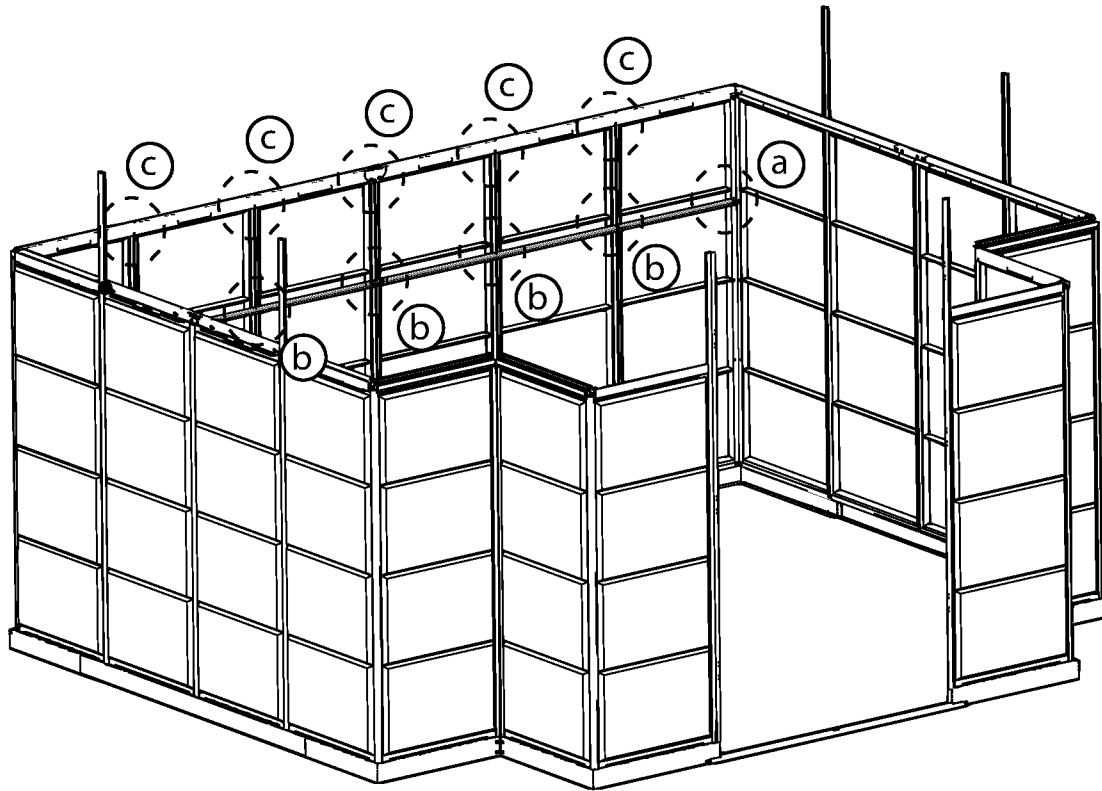
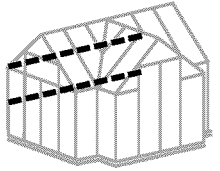

EN Throw away parts #7180
DE Werfen Sie weg Teil #7180
FR Jeter Pièces #7180
SP Pieza No. #7180 -tirar (a la basura)

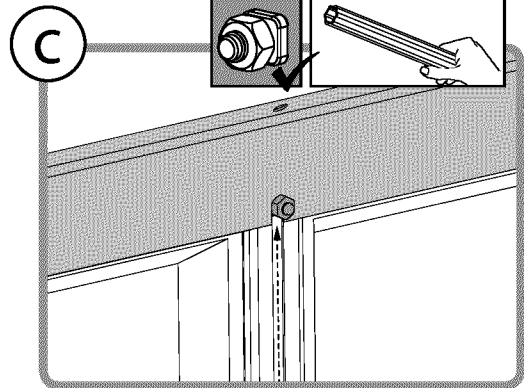
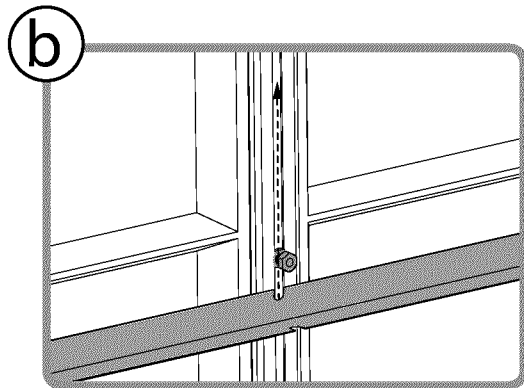
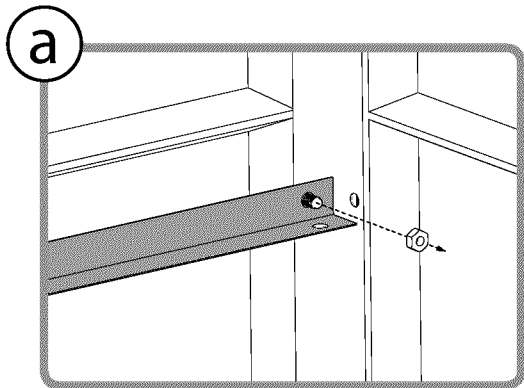

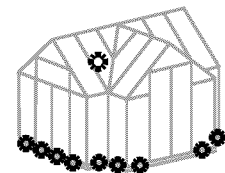

4008 1 328 40

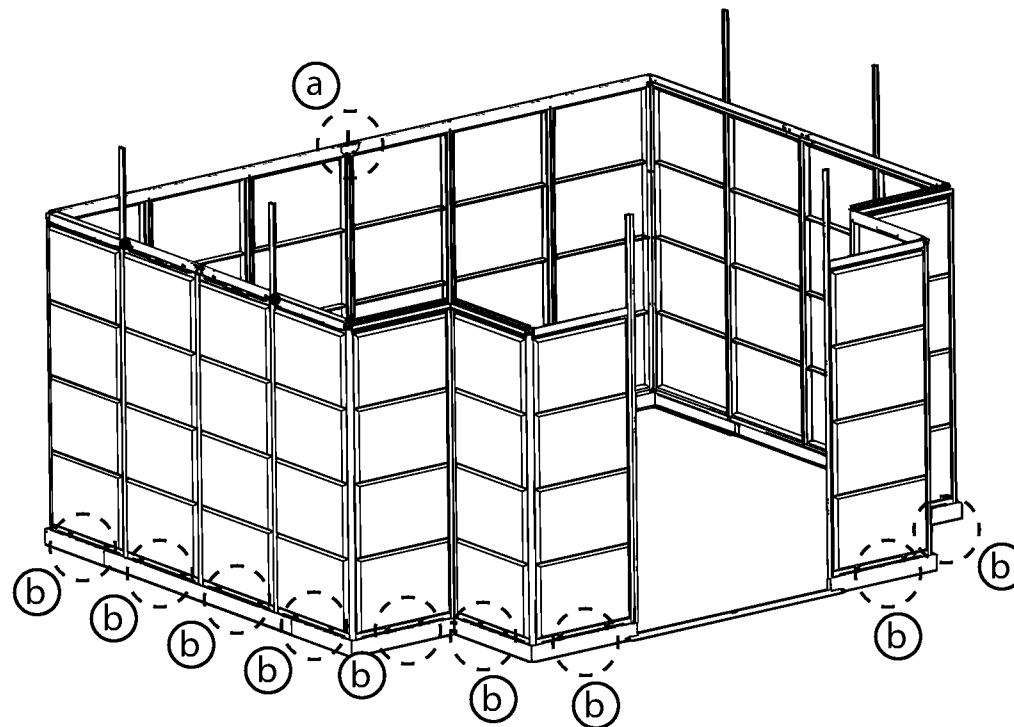
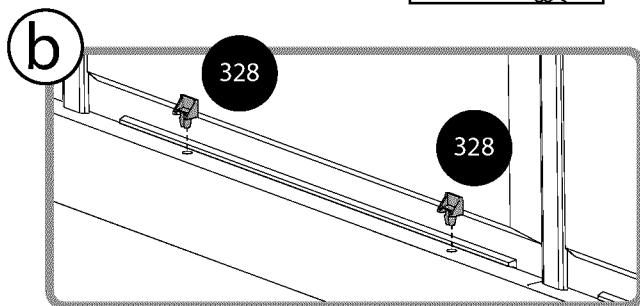
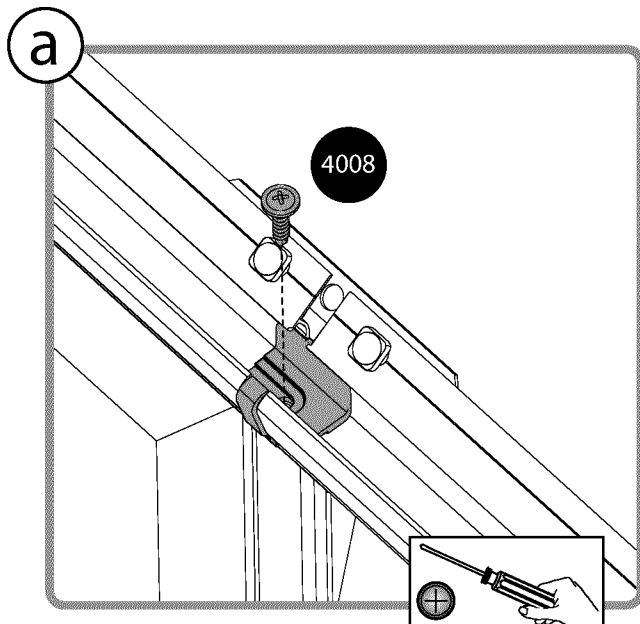

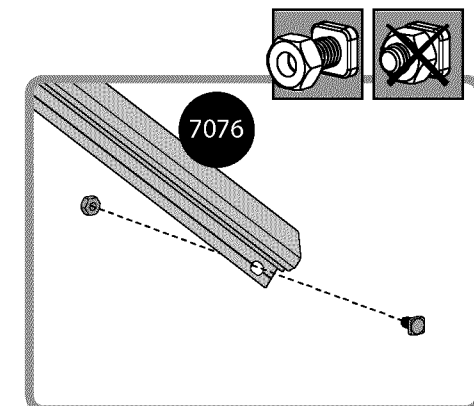
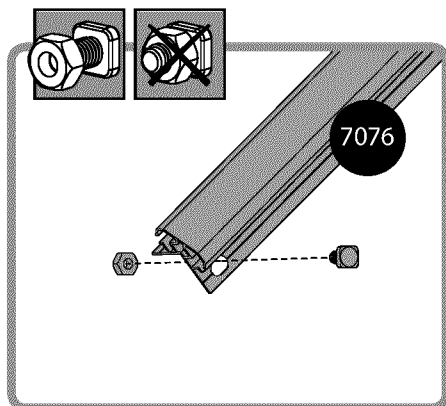
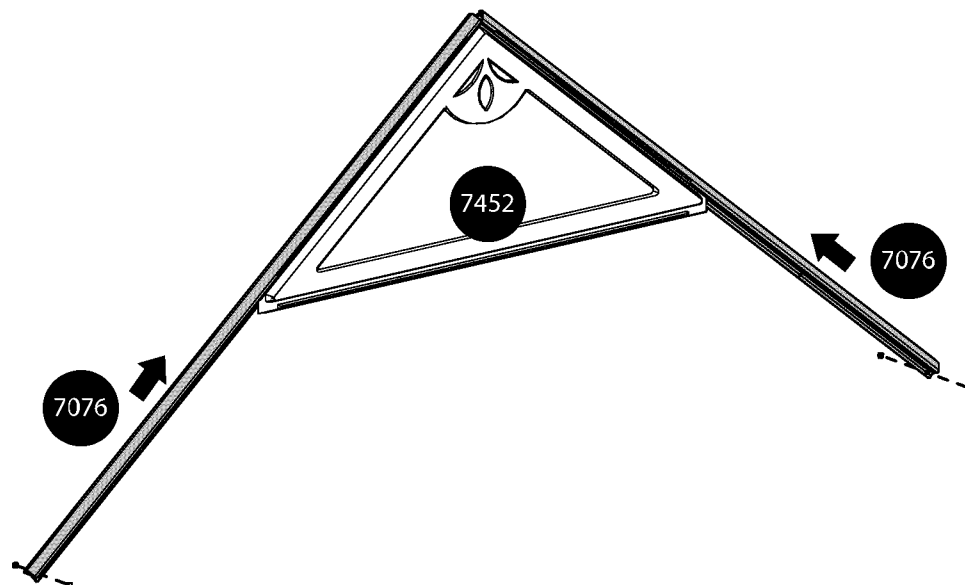
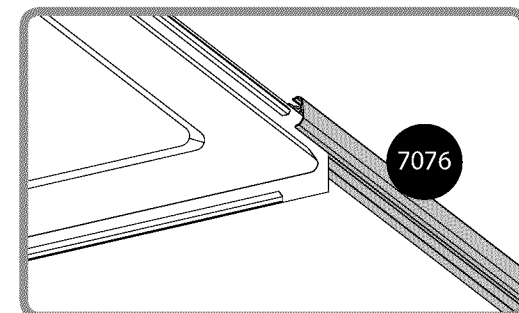
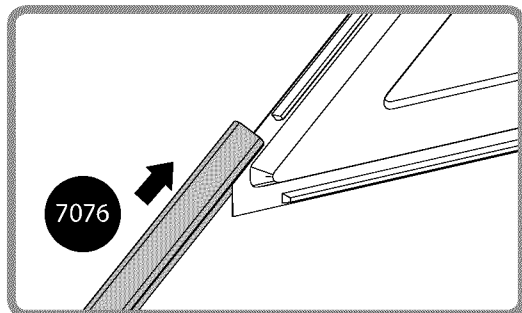
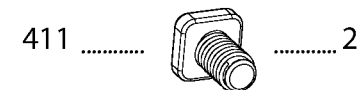
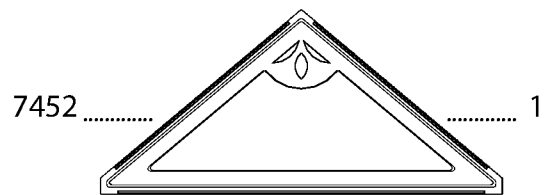
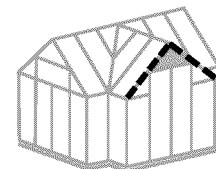

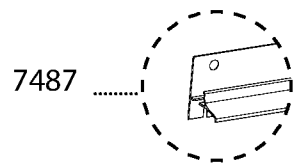
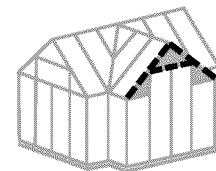

7487



1

559

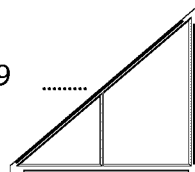

1

560

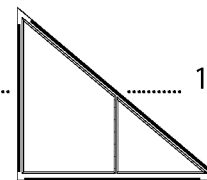

1

411



2

412



2

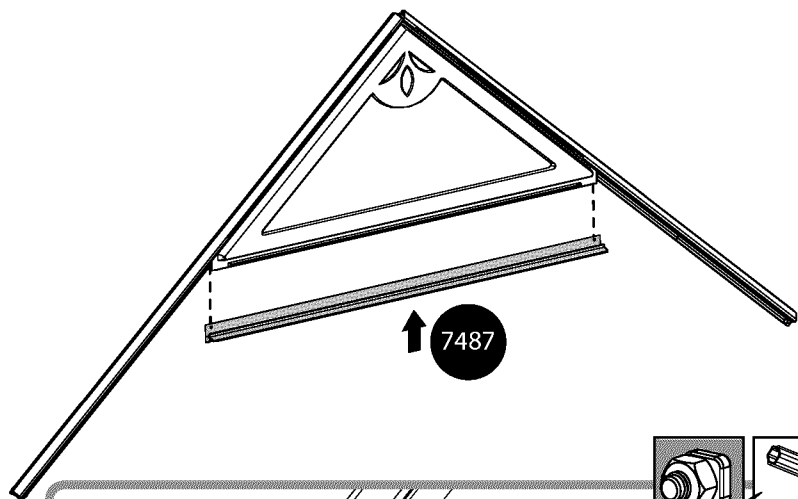

7487

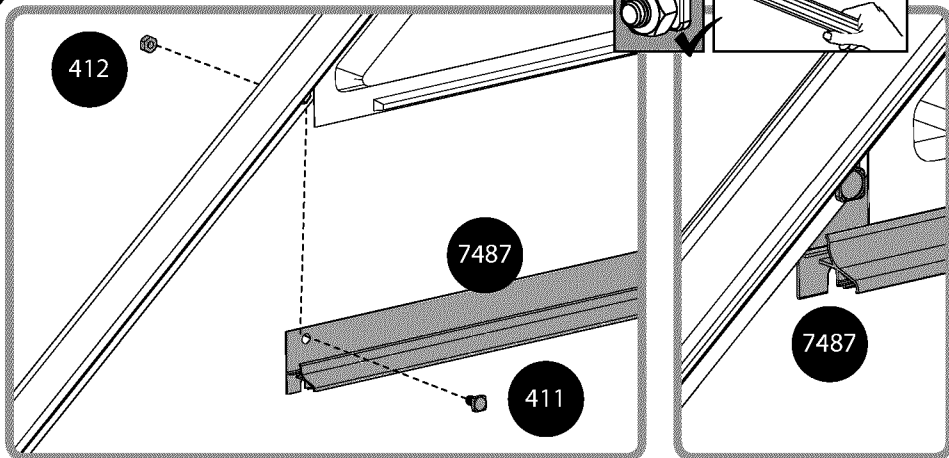

412

7487

411

7487

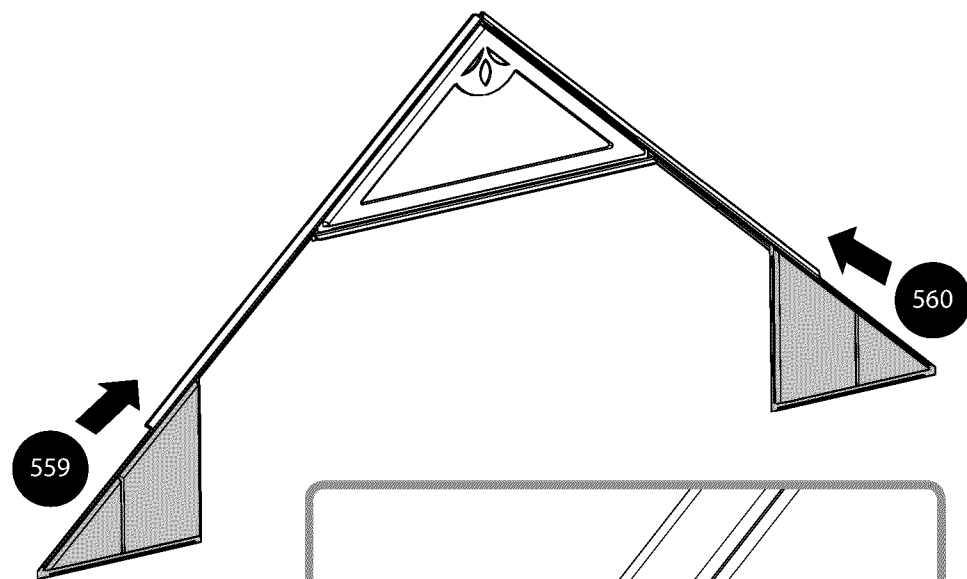

559

560

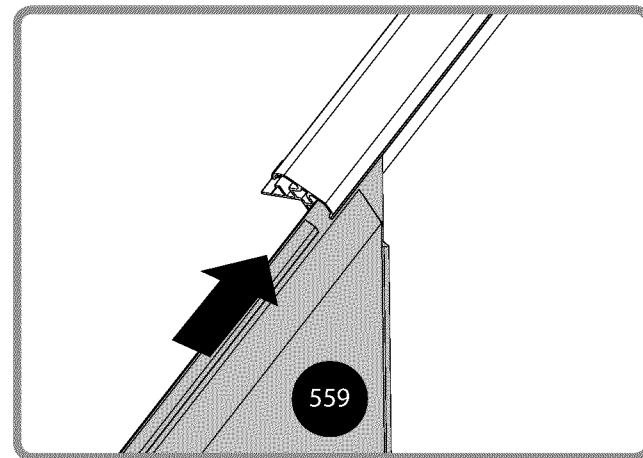

559

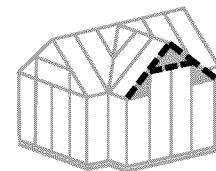

411  4 412  4

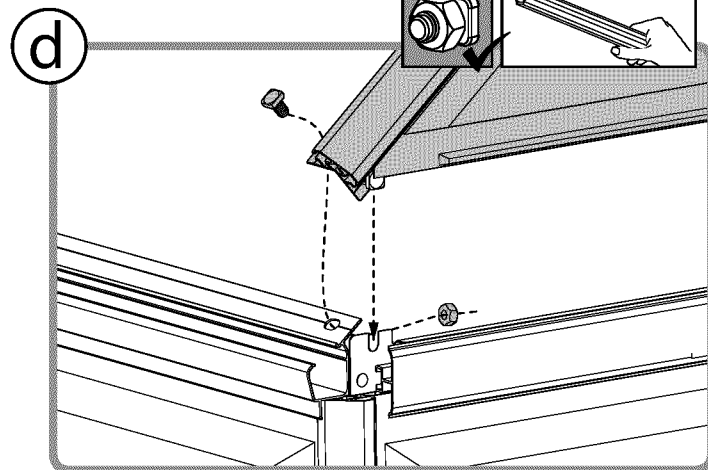
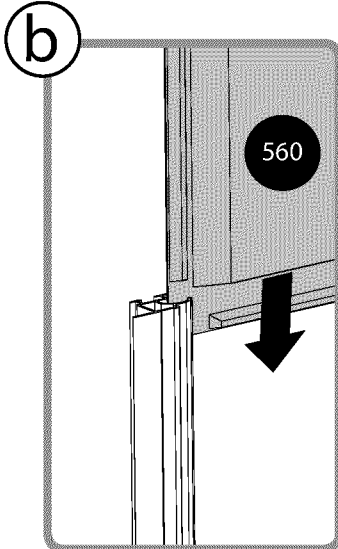
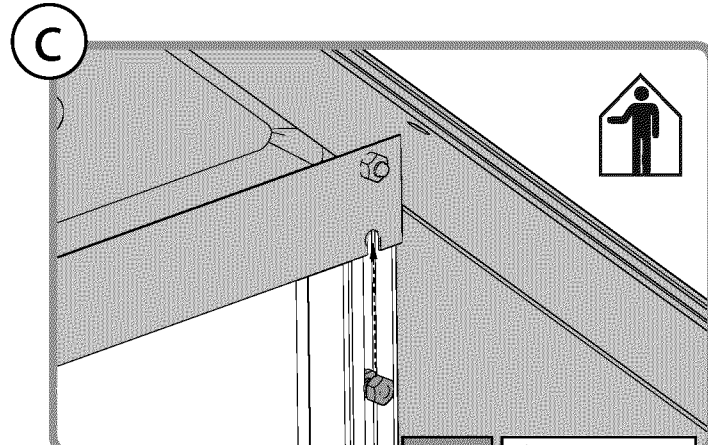
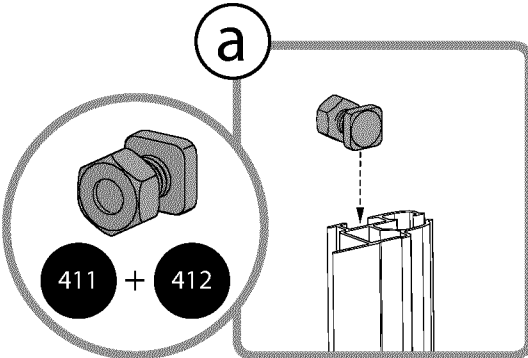
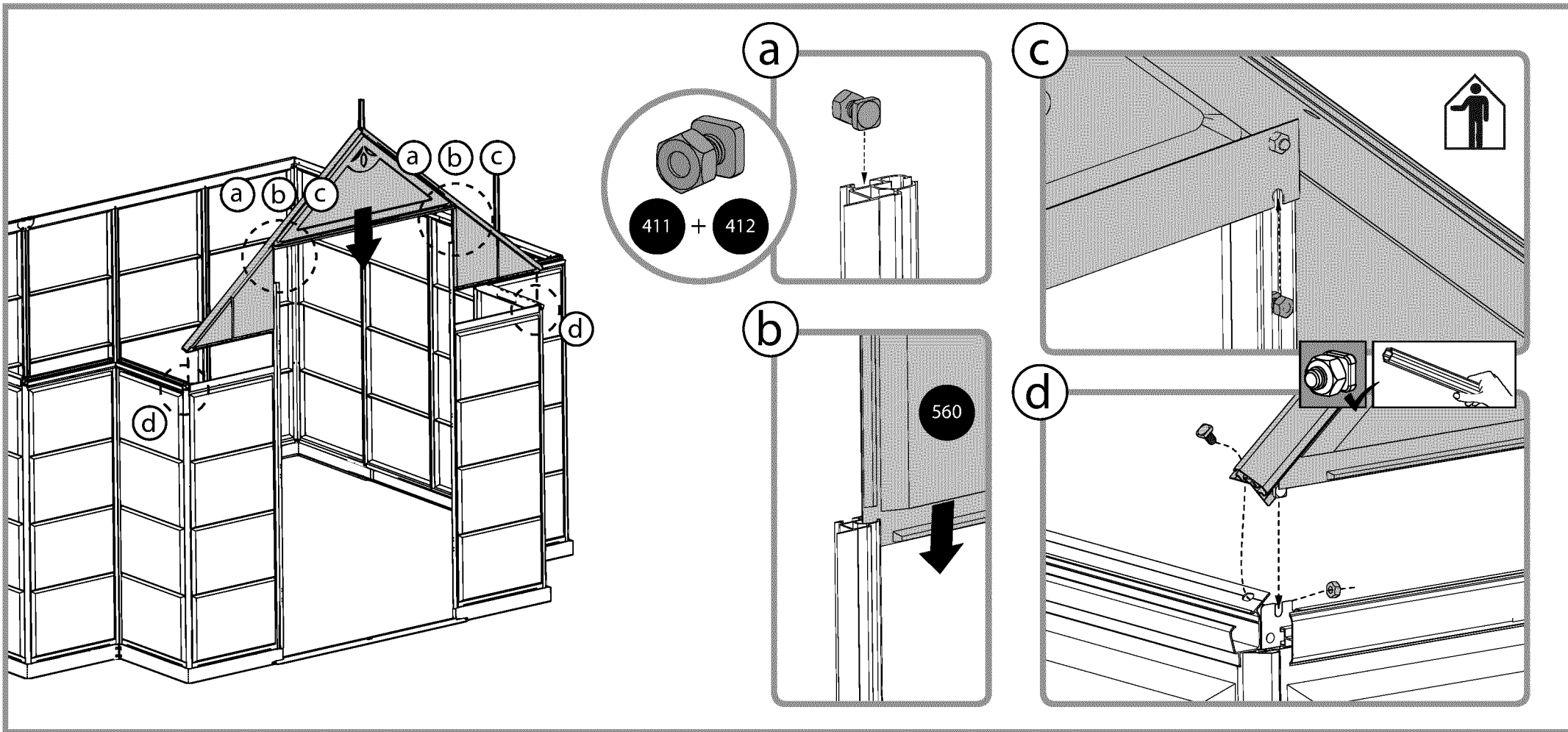

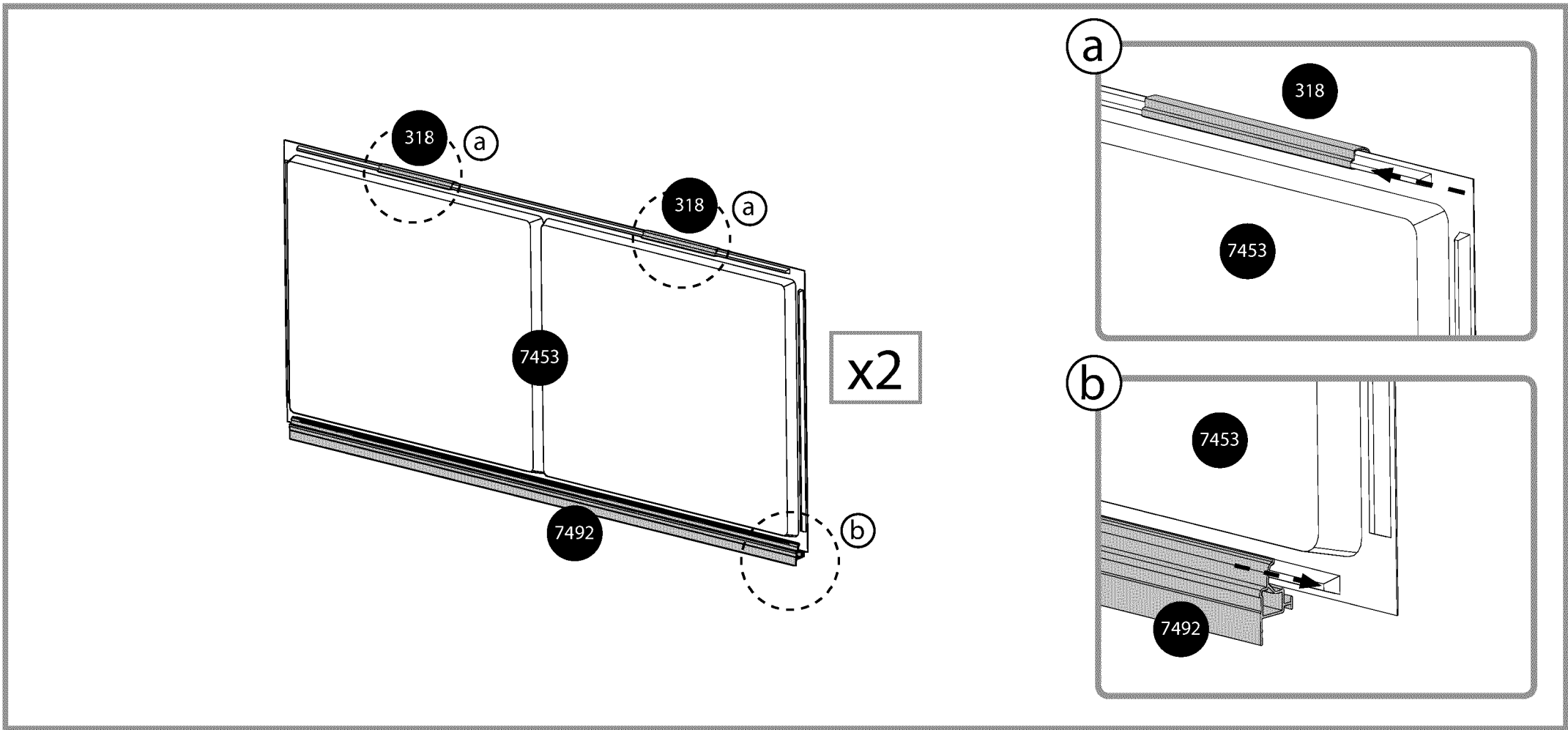
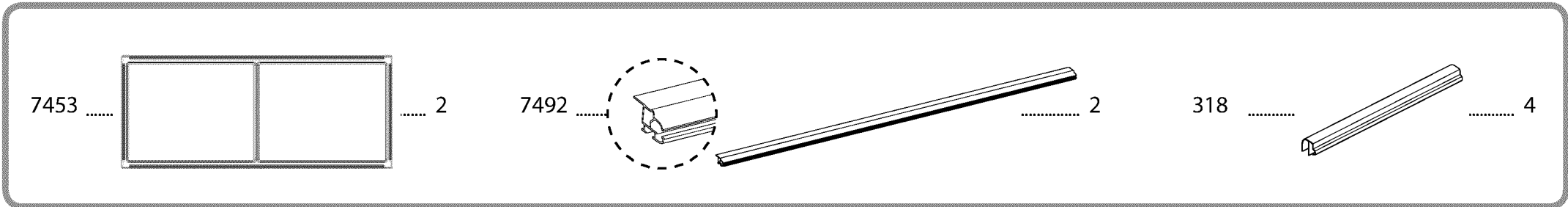
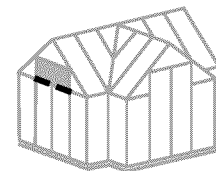

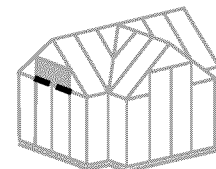

..... 2 466 8 461 8

a

b

c

x8

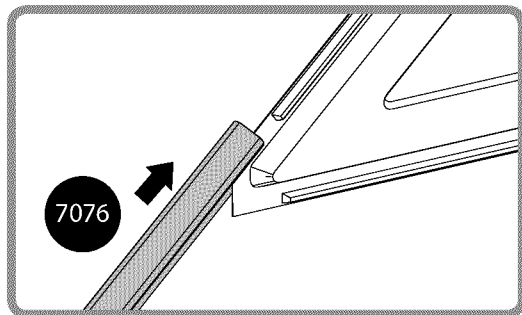
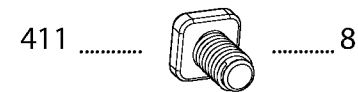
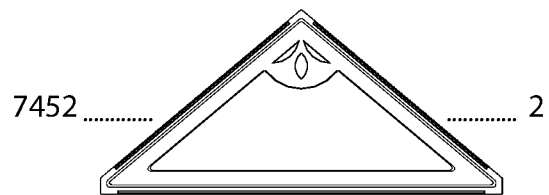
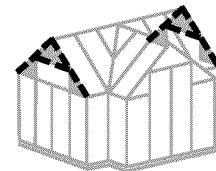

x2

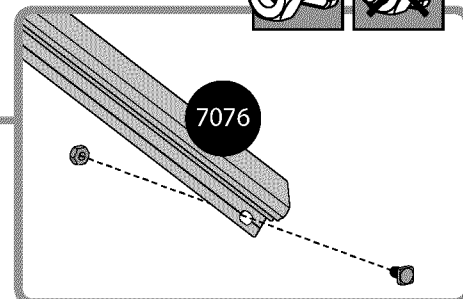
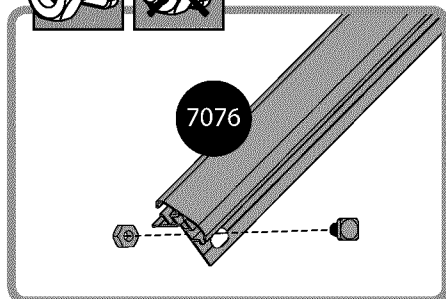
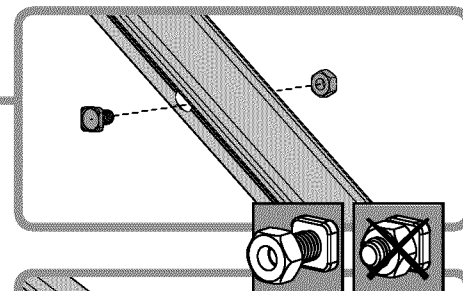
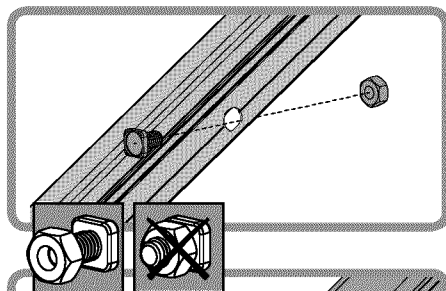
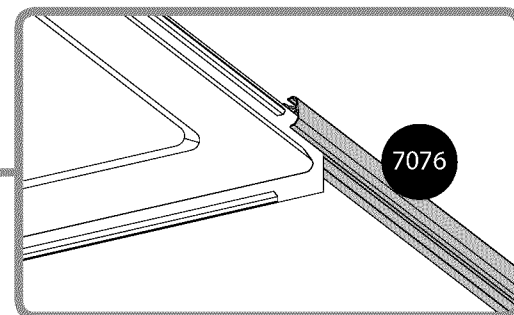

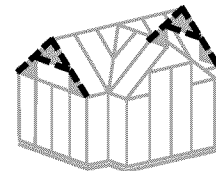

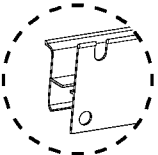

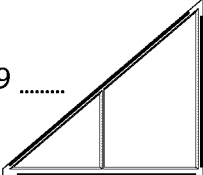
7488  2

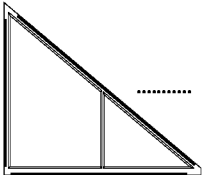
559  2

560  2

411  4

412  4

x2

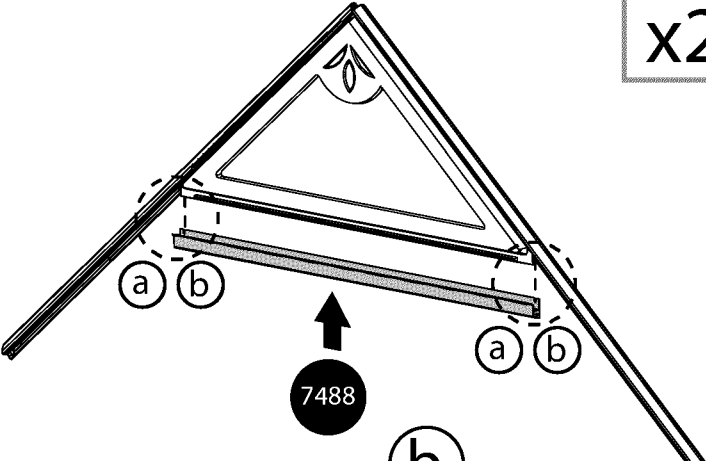

a

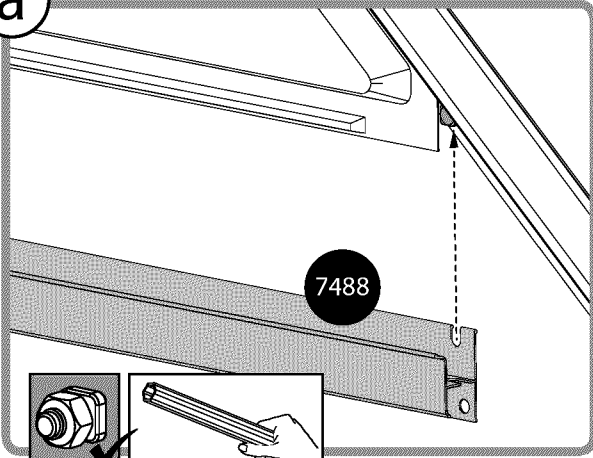

b

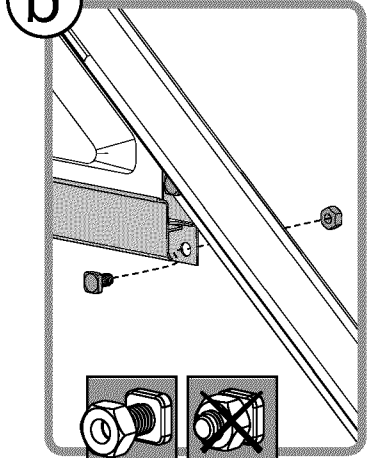

7488

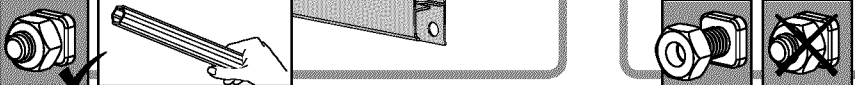

x2

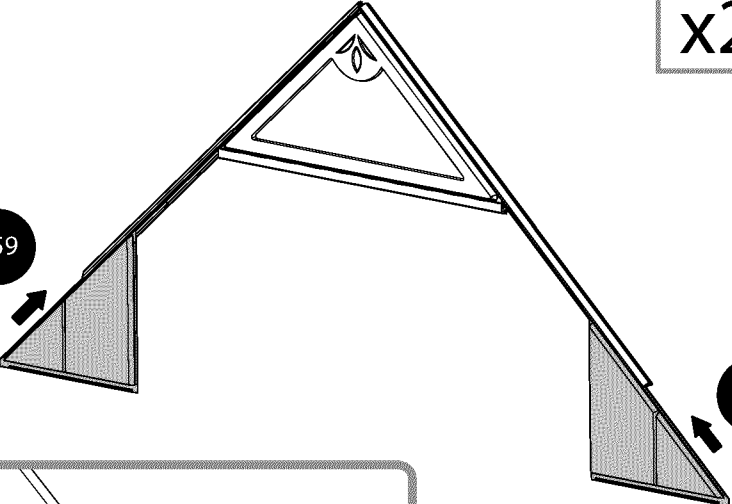

559

560

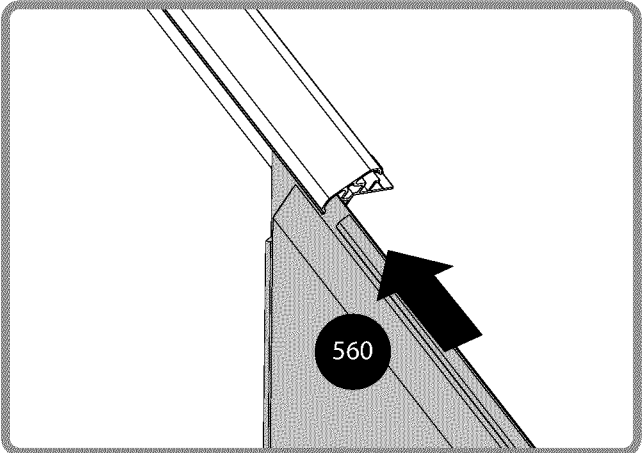

560

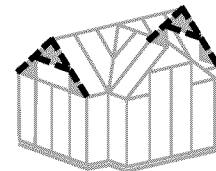

411  4 412  4

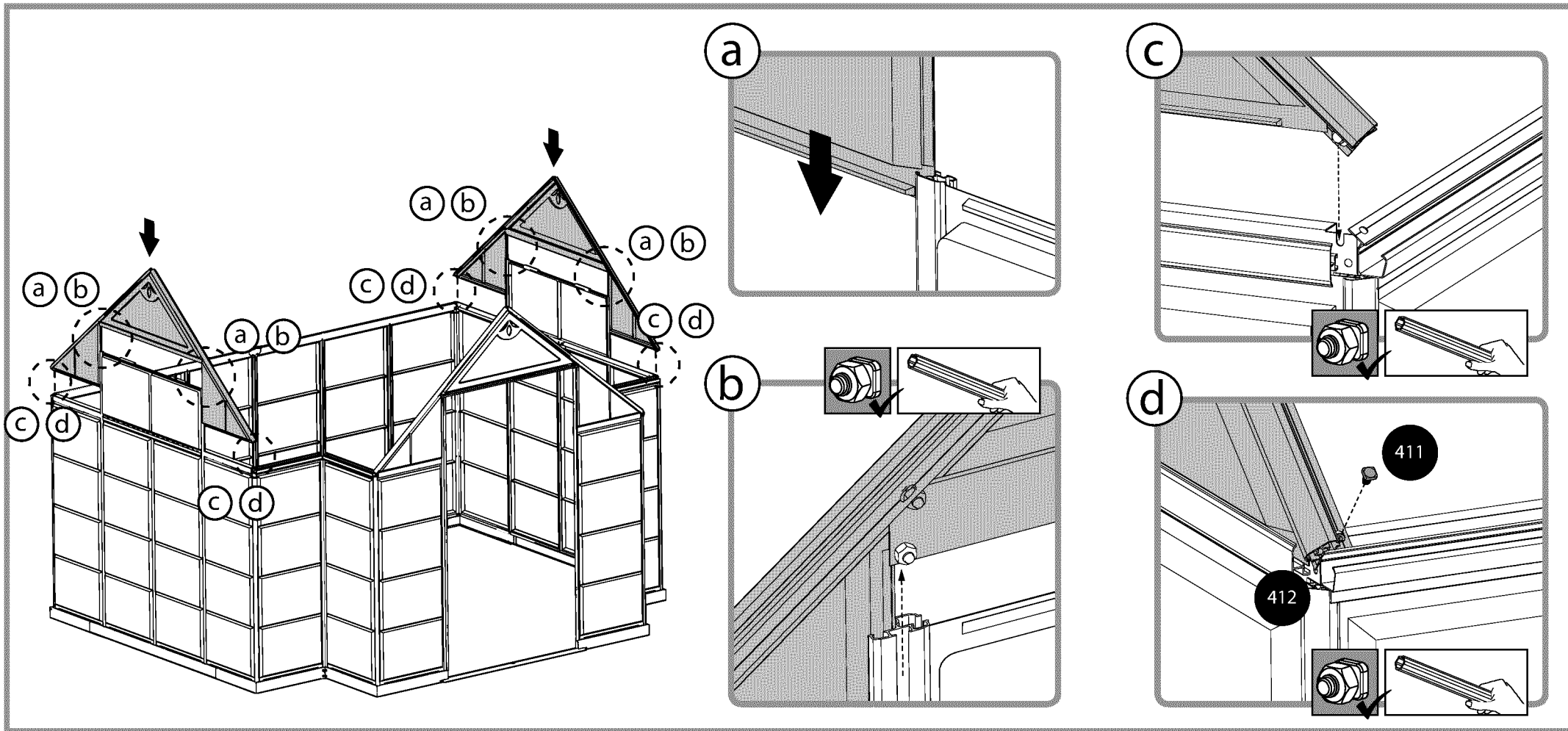

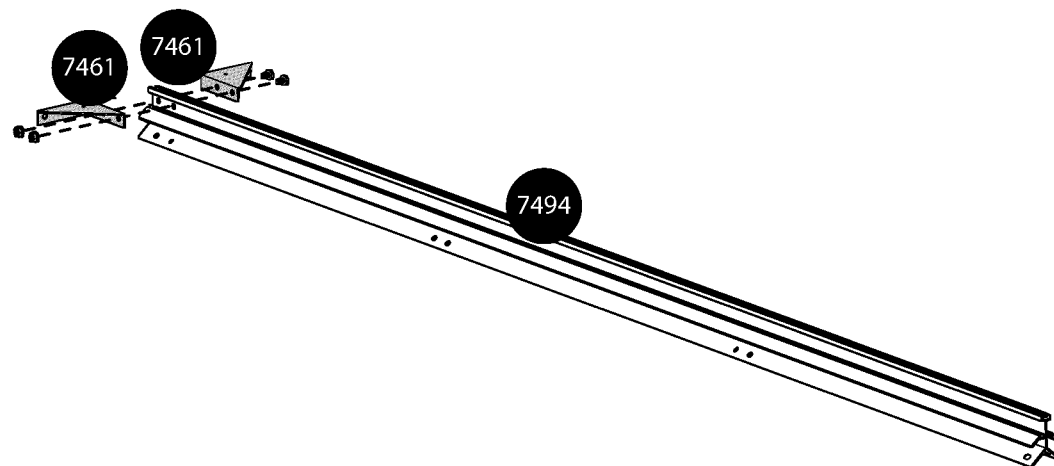
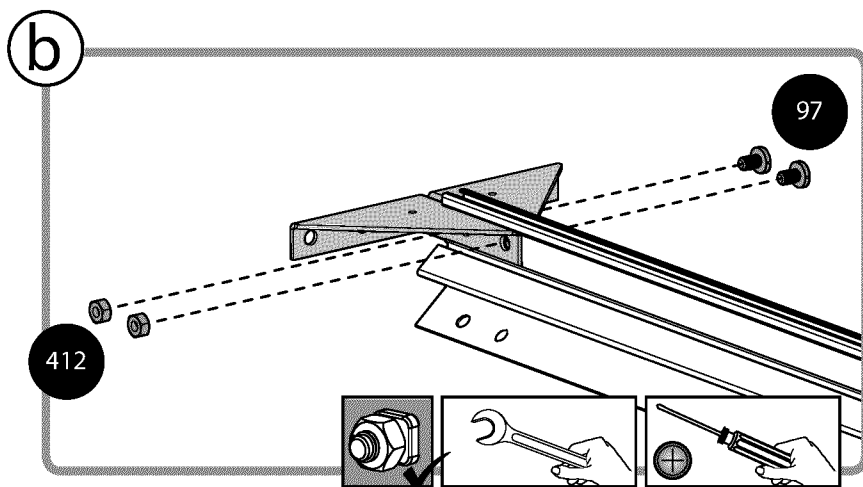
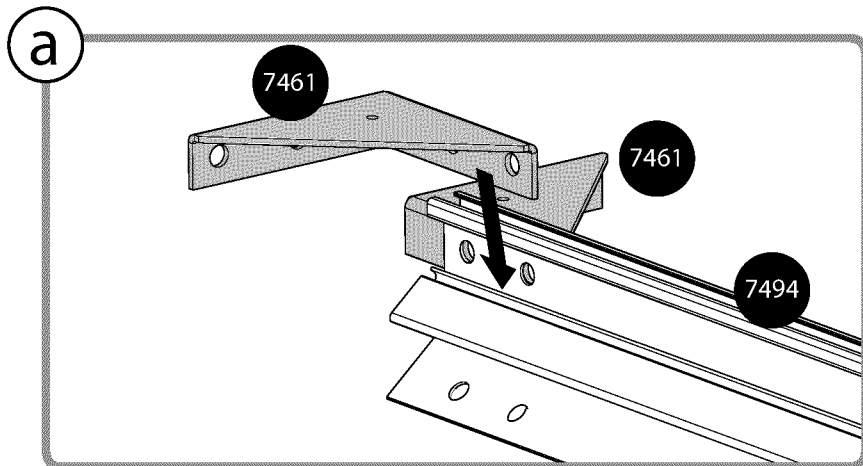
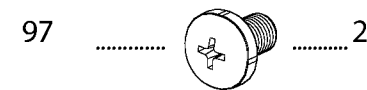
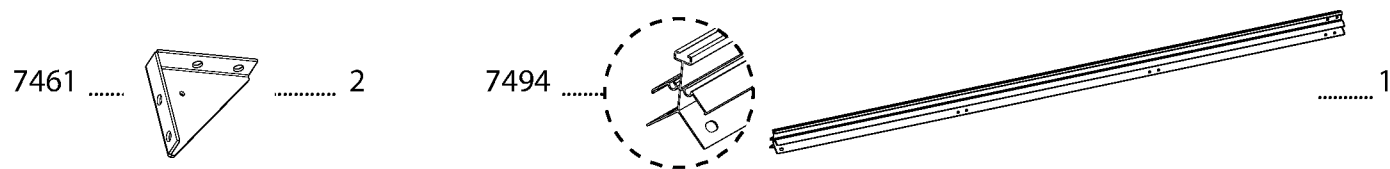
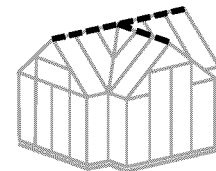

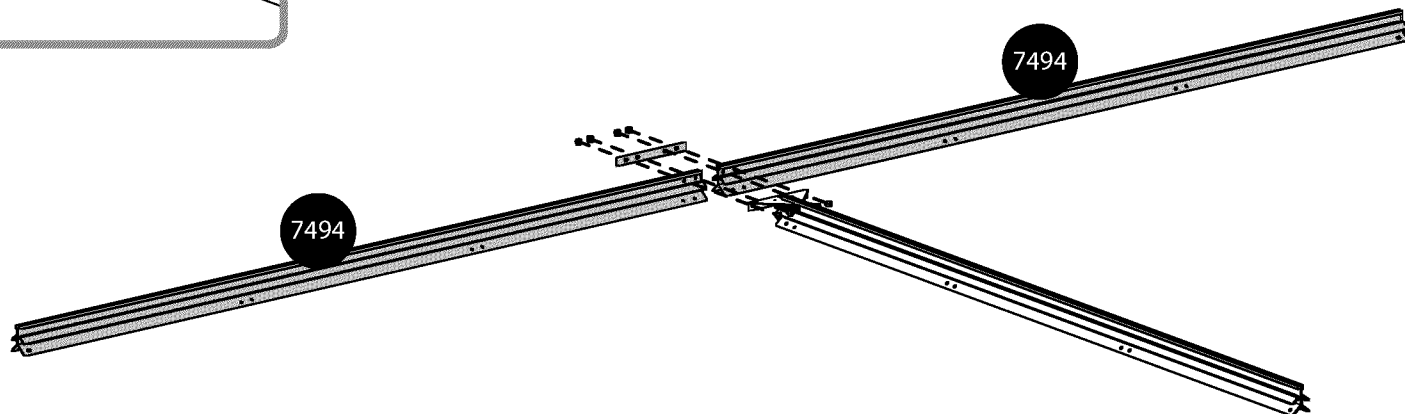
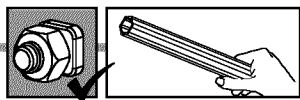
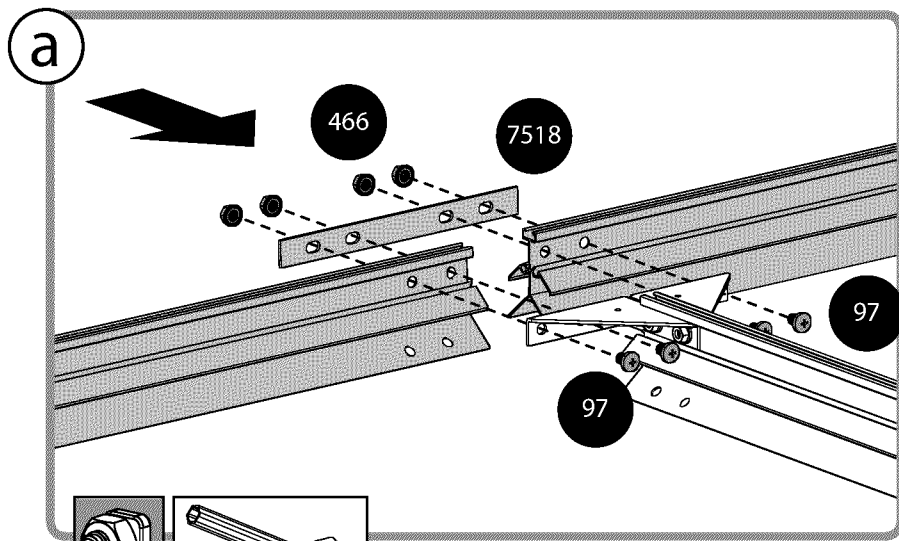
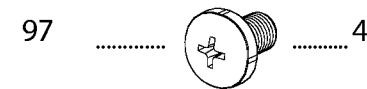
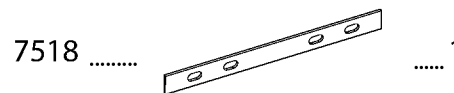
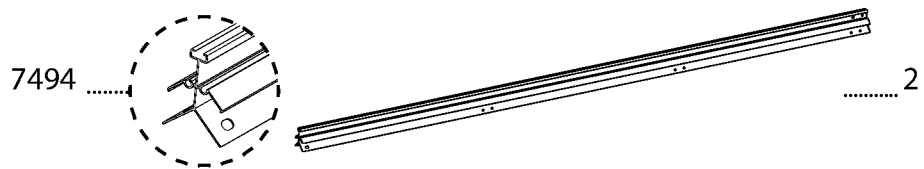
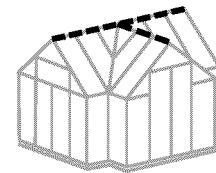

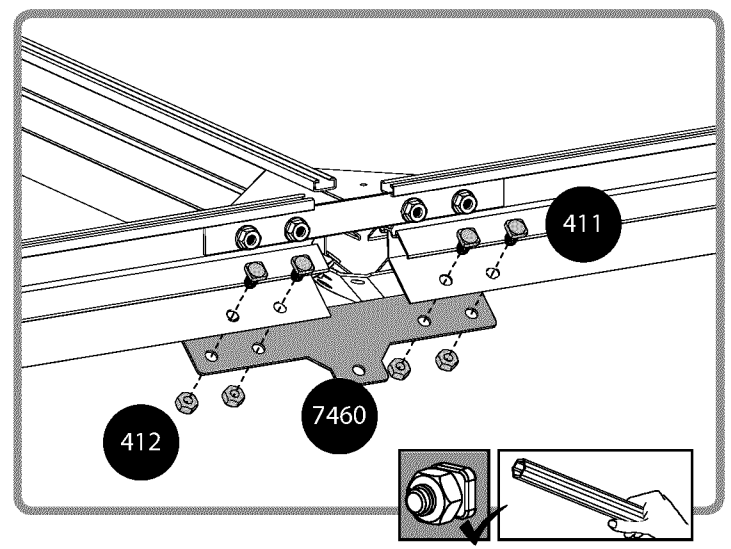
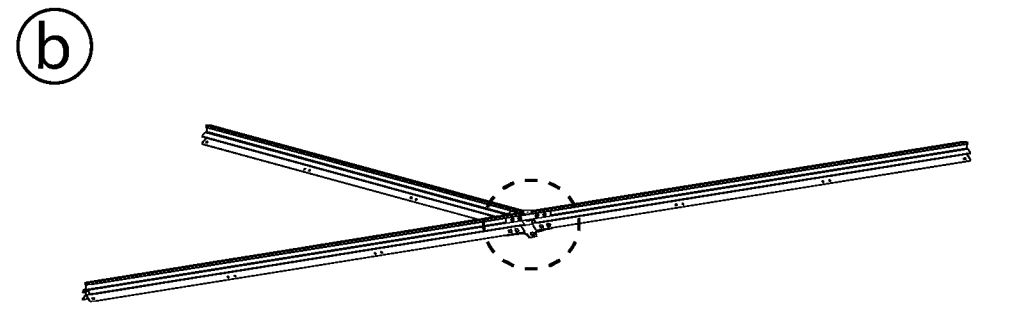
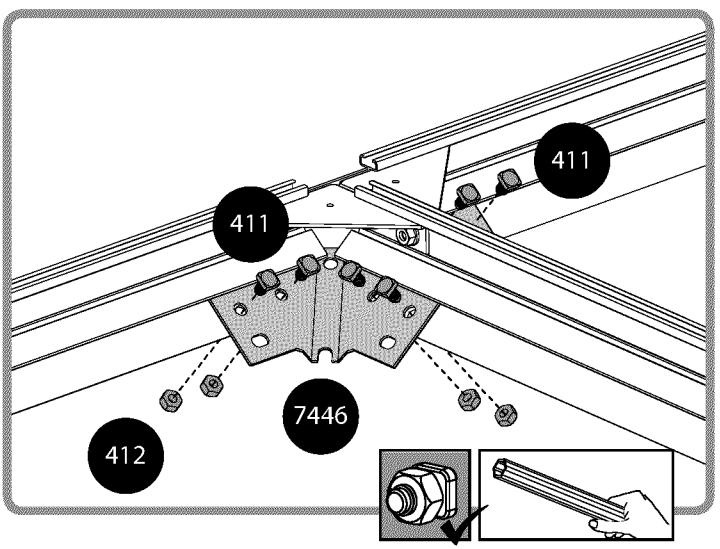
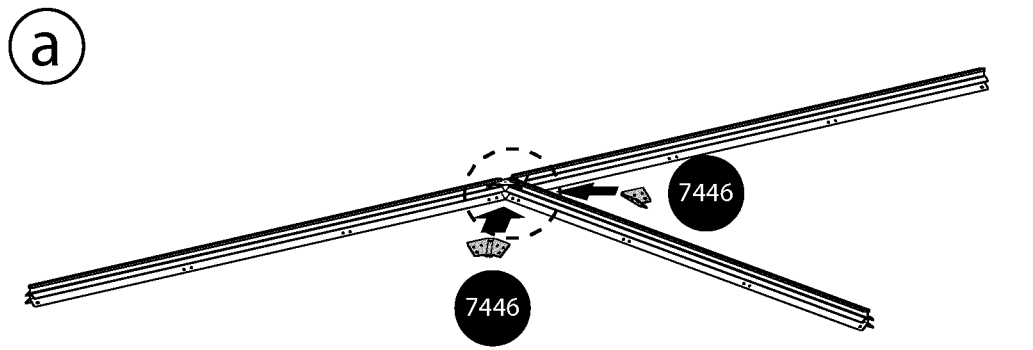
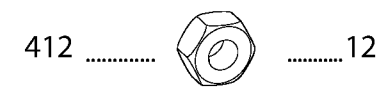
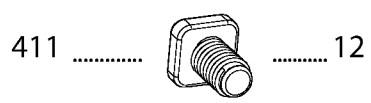
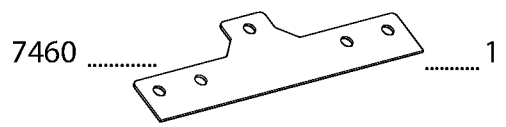
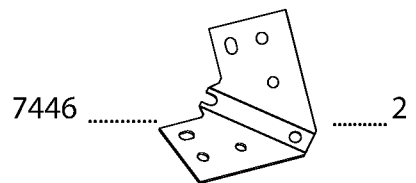
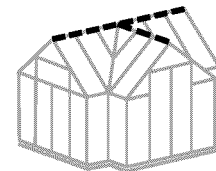

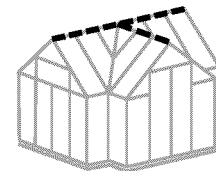

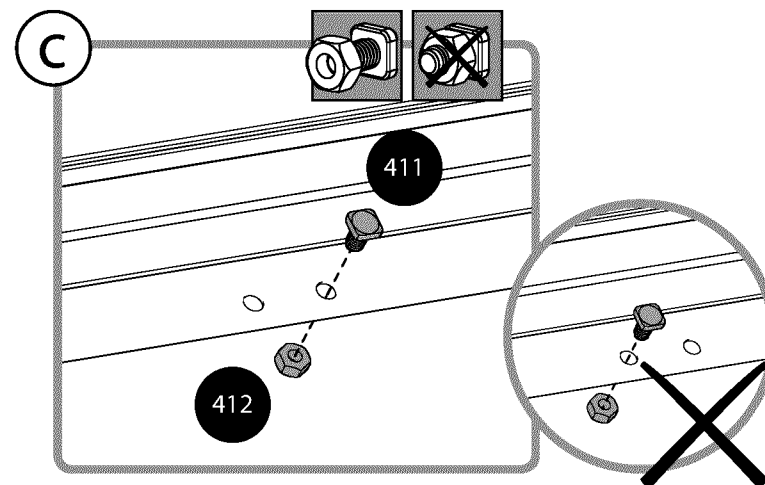
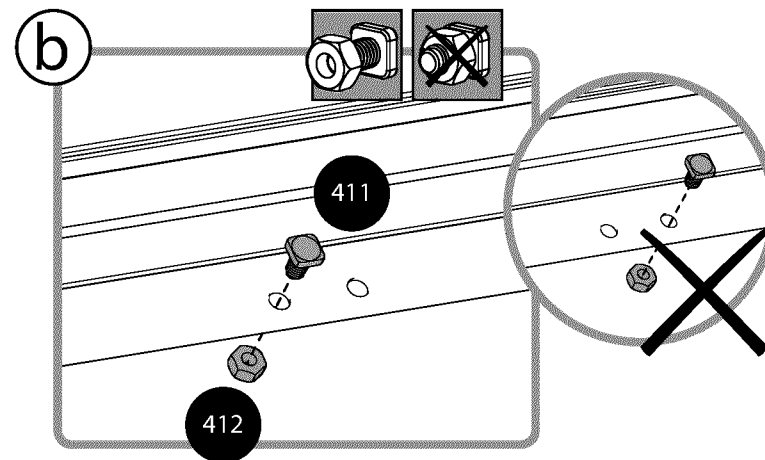
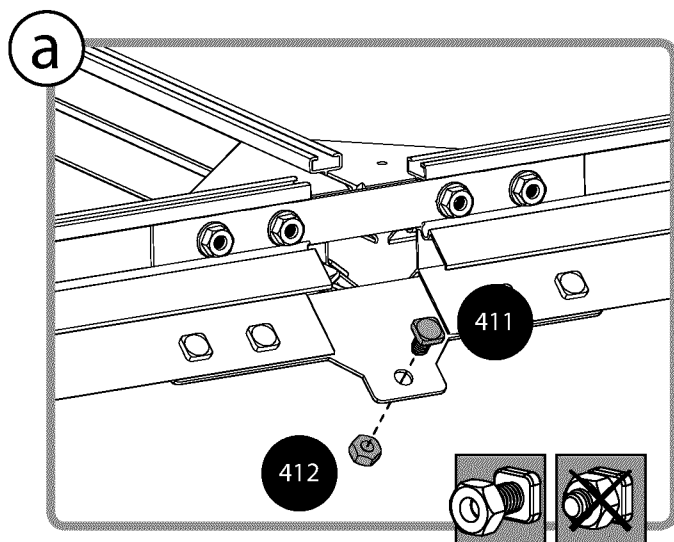
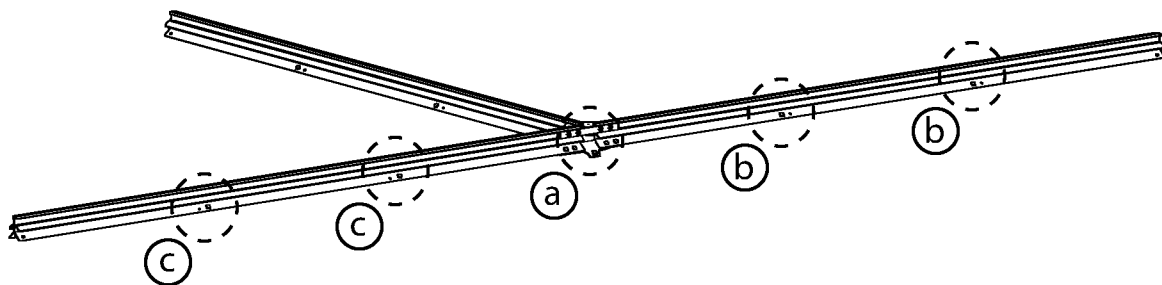

411  5 412  5

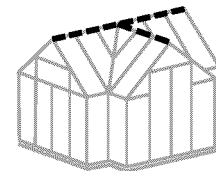



411  8

412  8

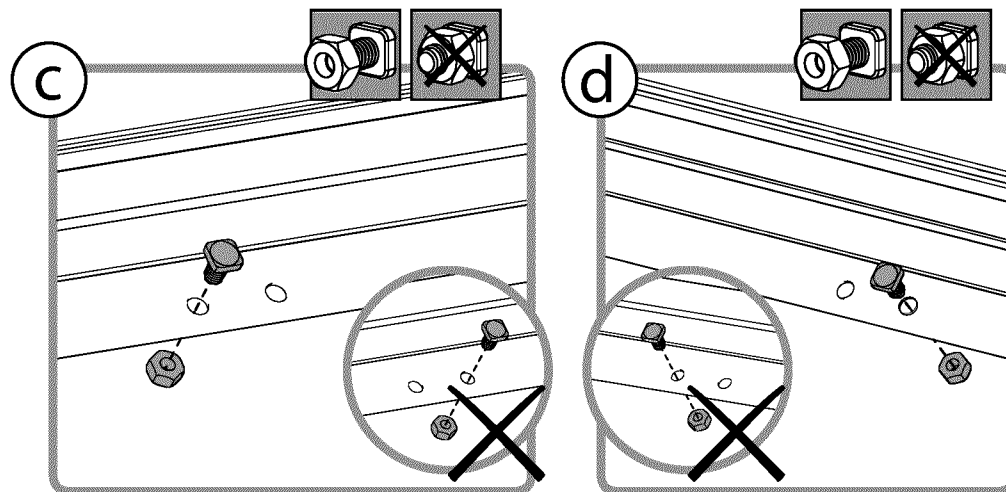
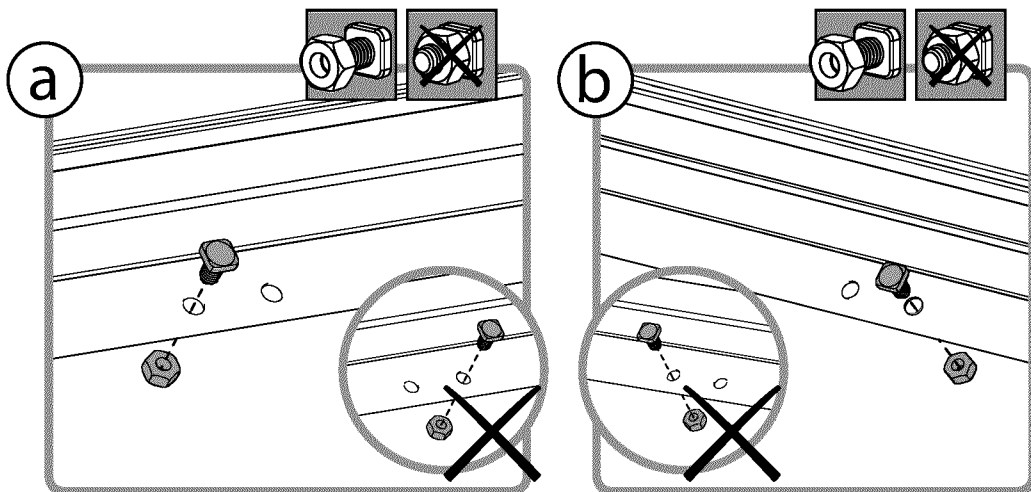
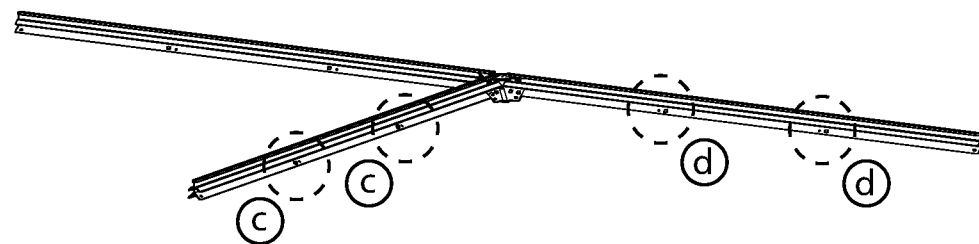
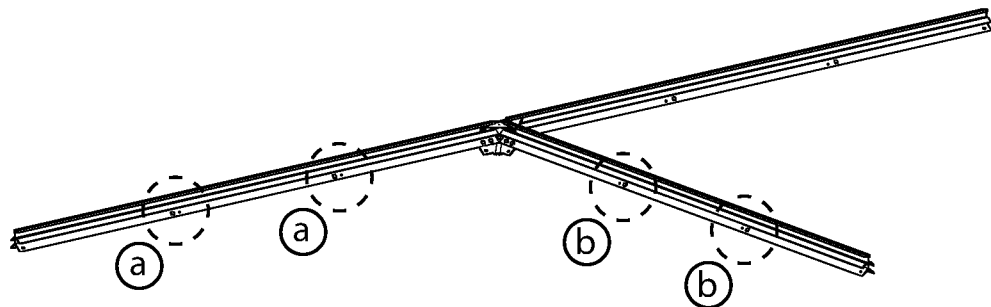

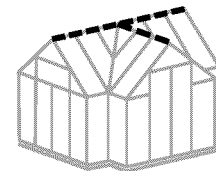

411  6 412  6

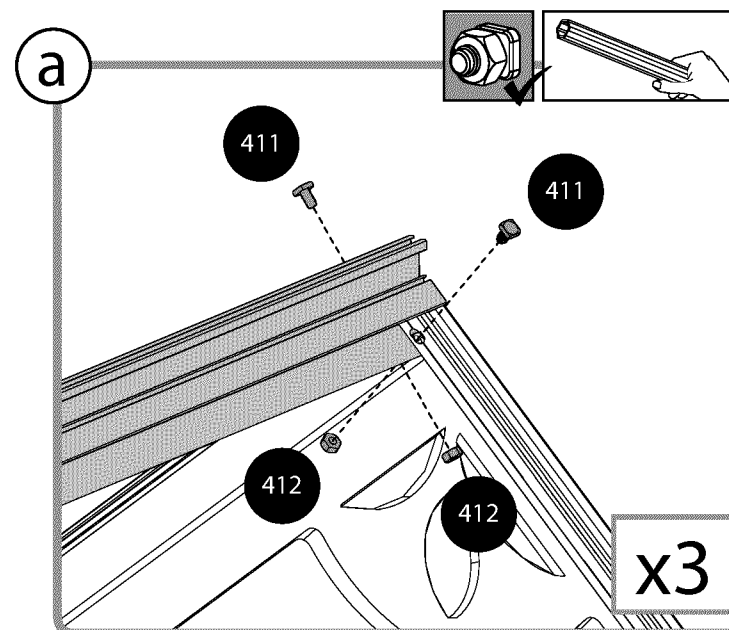
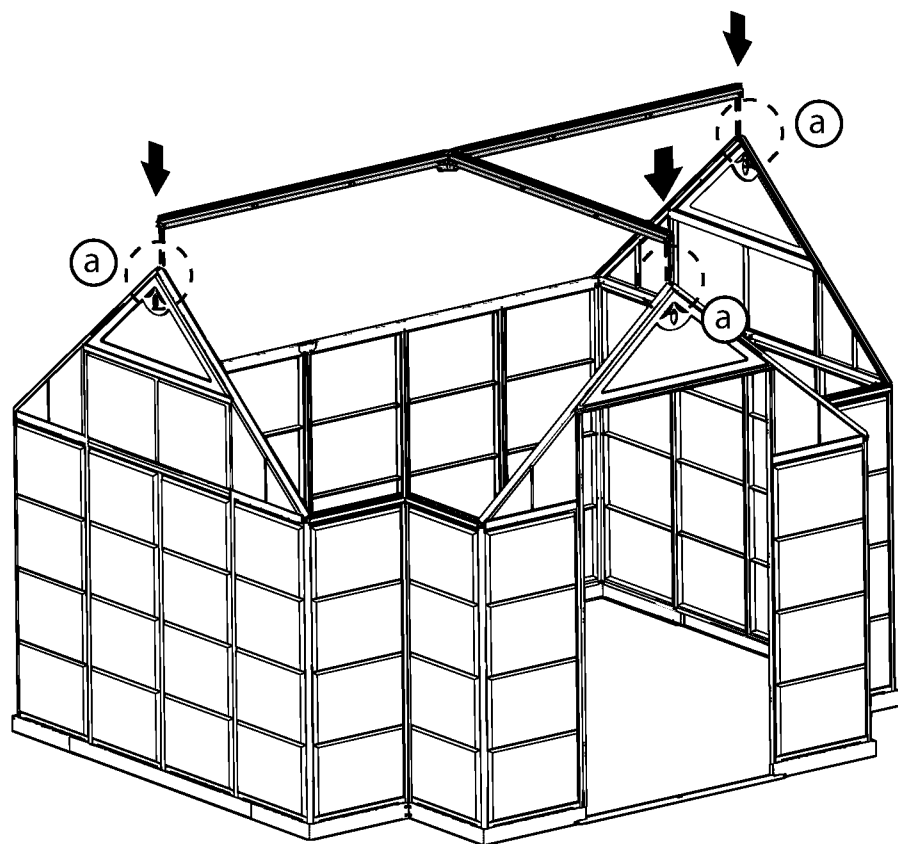

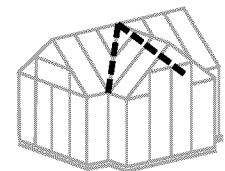

7495 2 7284 6 7446 2

411 6

412 8

x2

a

b

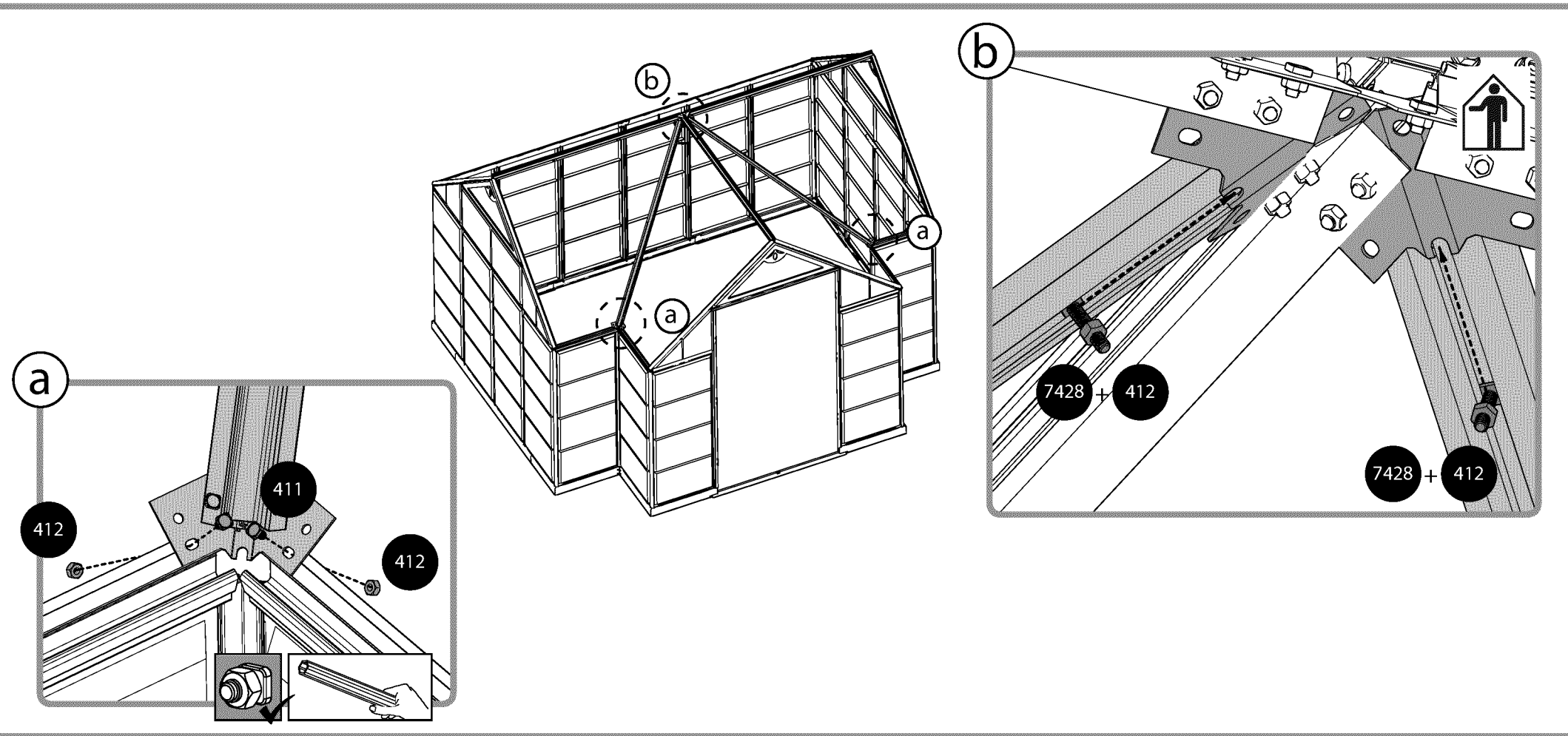
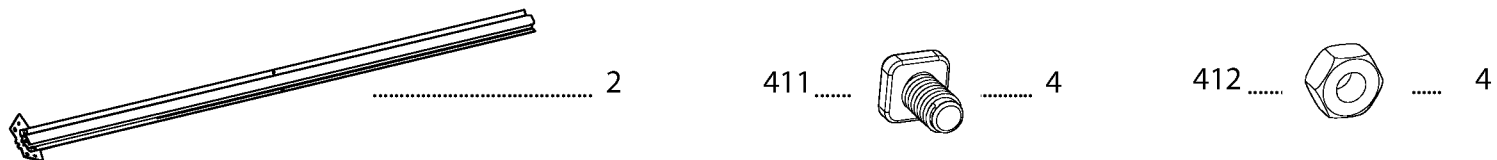
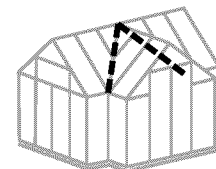

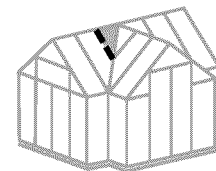

7490 1

7459 1

318 1

411 1

412 1

a

b

7490

7459

318

This side out

This side out

This side out

a

b

7459

318

7490

7459

c

d

411

412

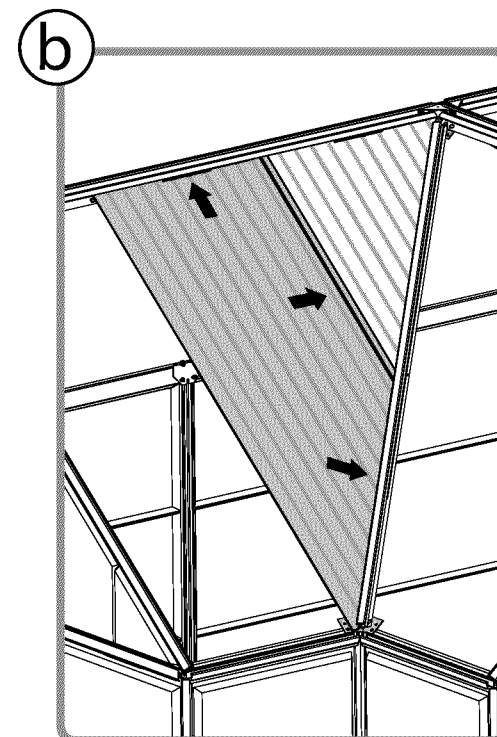
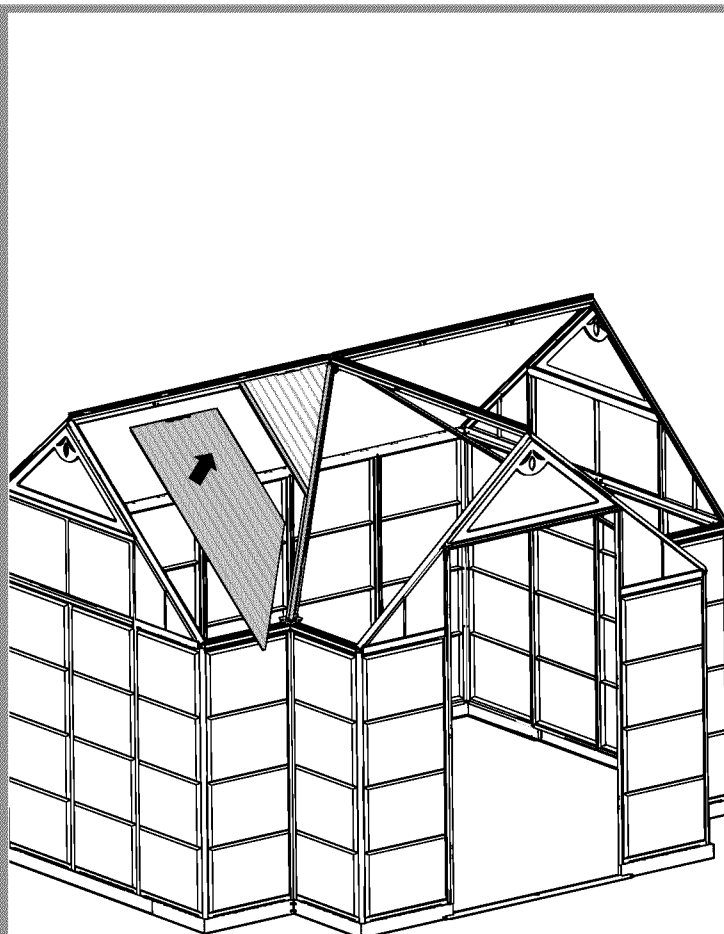
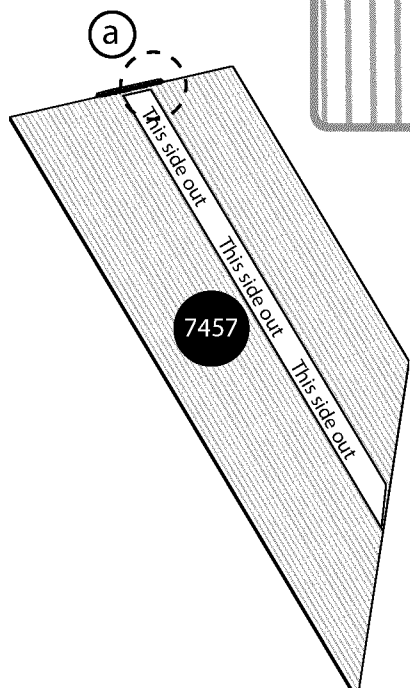
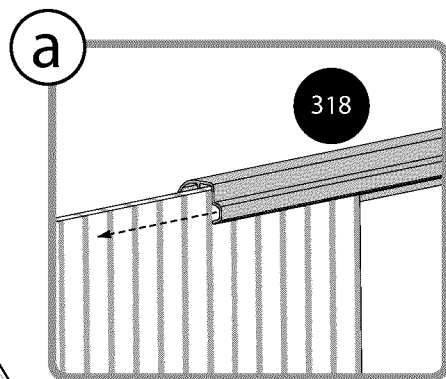
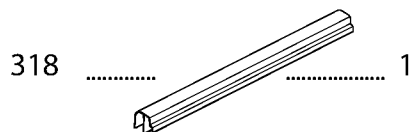
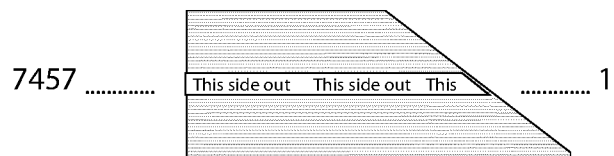
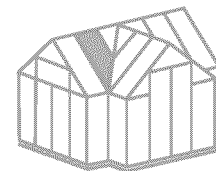

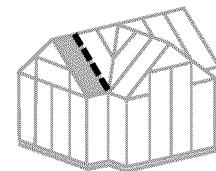

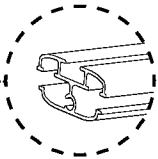

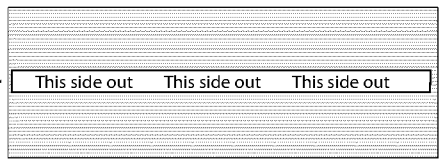

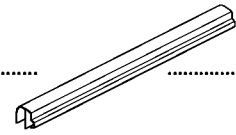

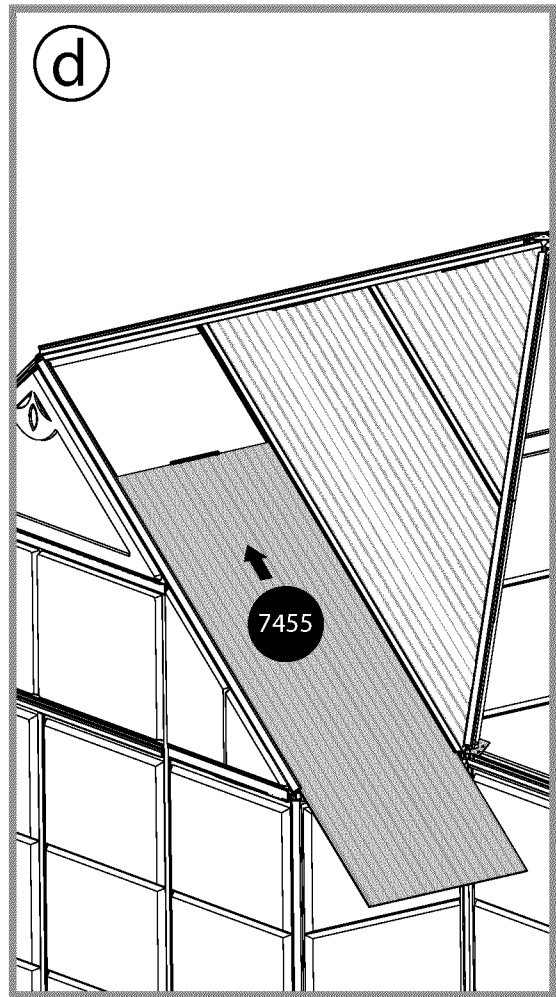
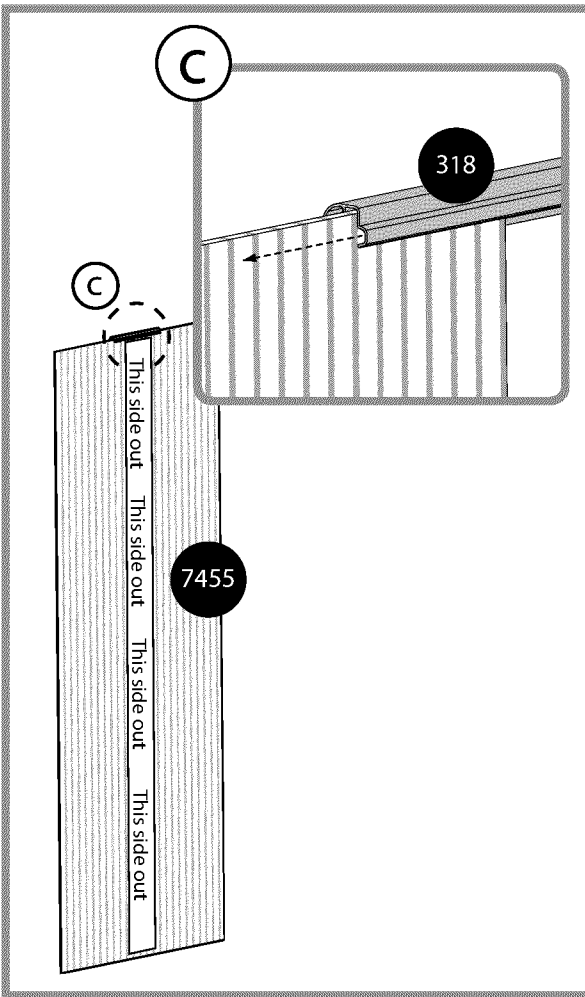
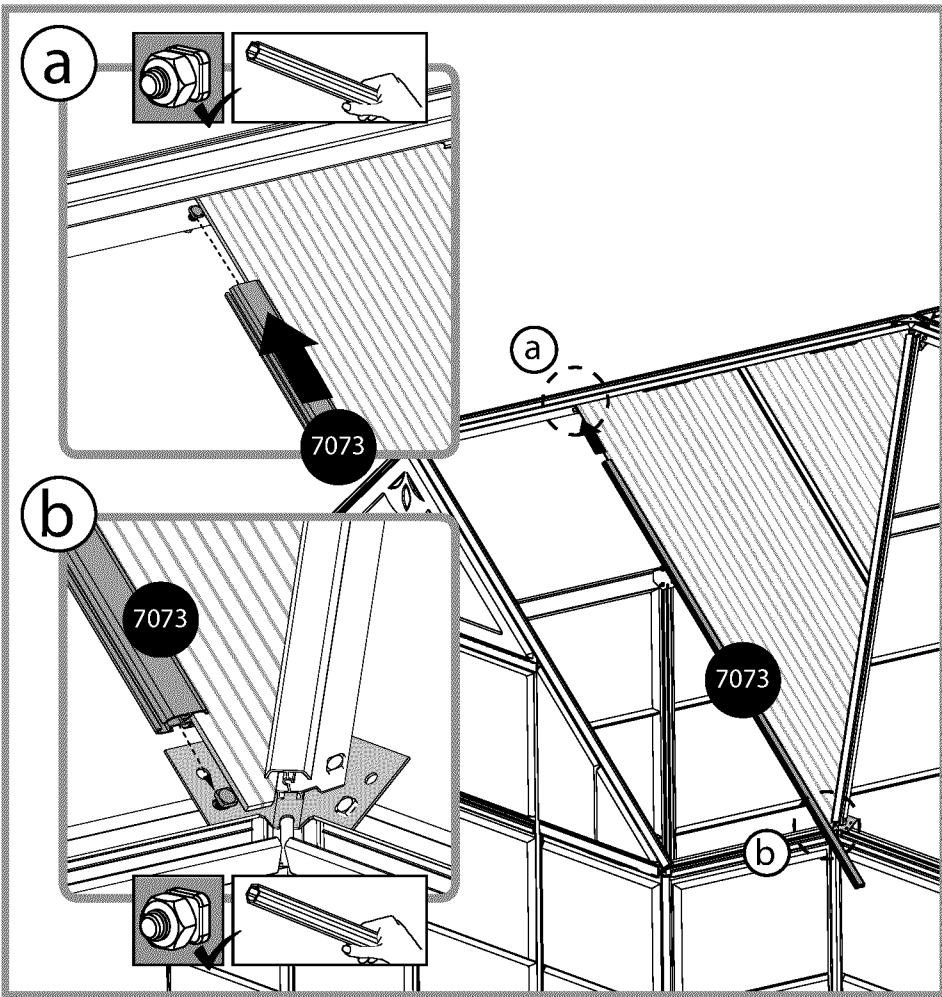
7073  1

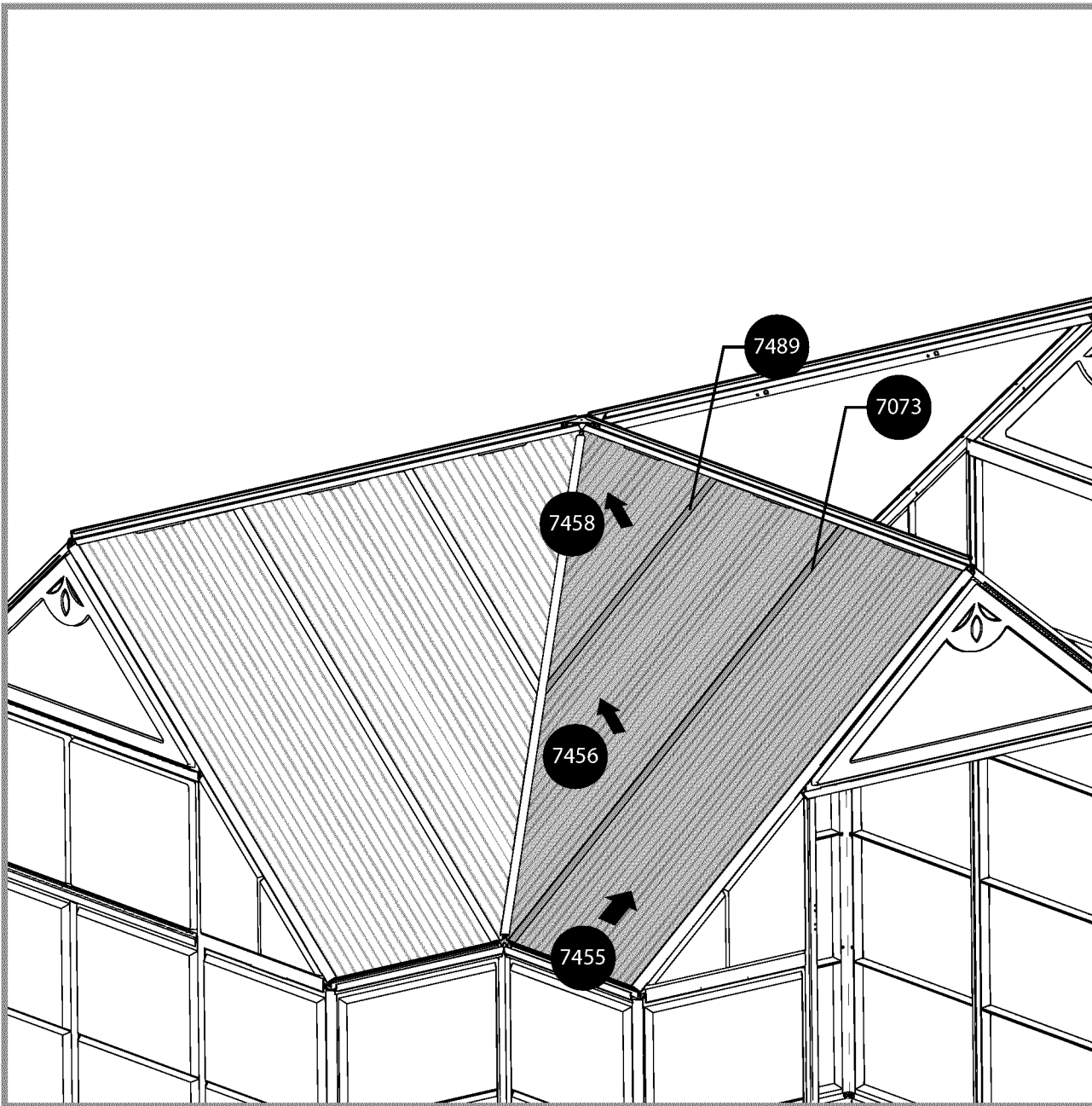
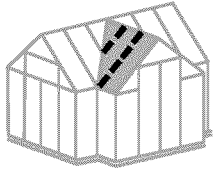
7455  1

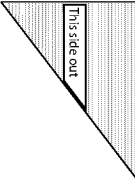
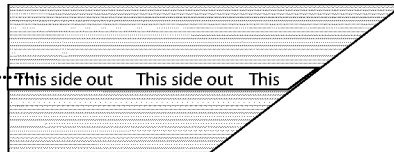
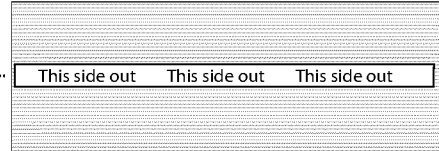
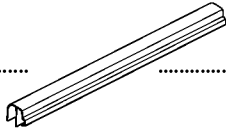
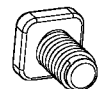
318  1

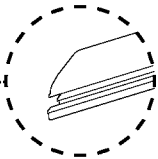

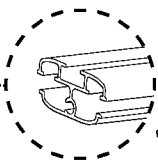

- 7458  1
- 7456  1
- 7455  1
- 318  3
- 411  1
- 412  1
- 7489   1
- 7073   1

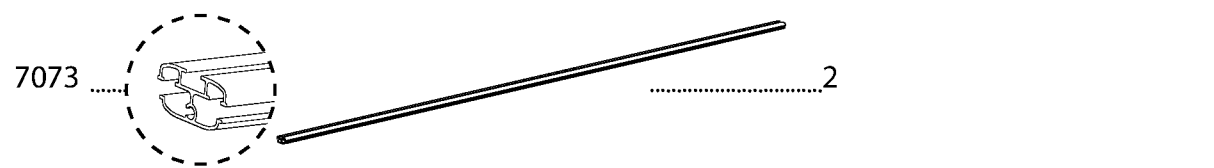
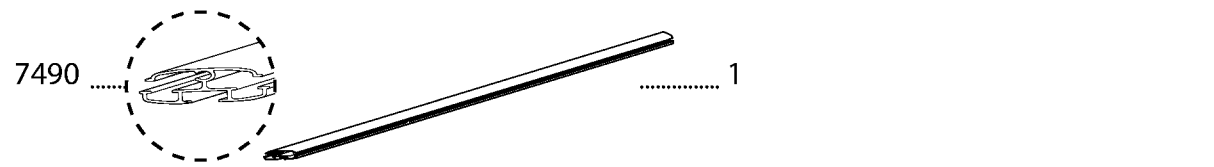
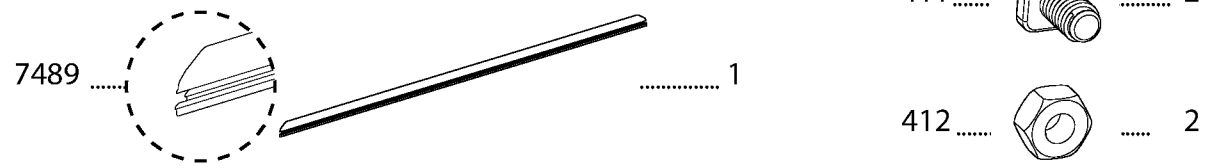
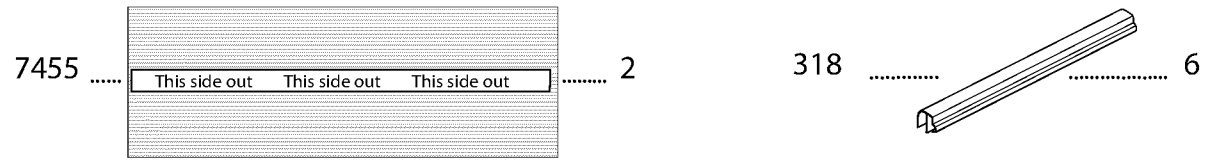
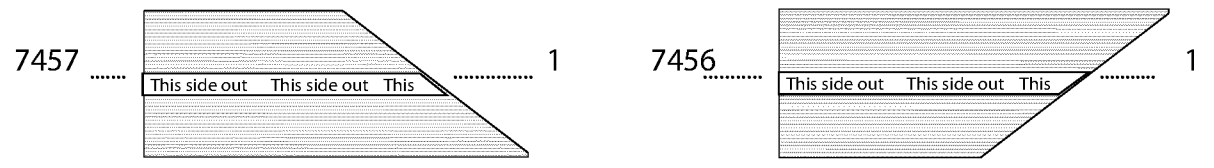
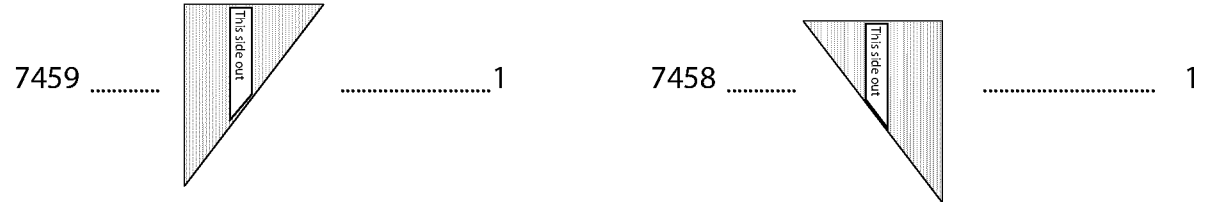
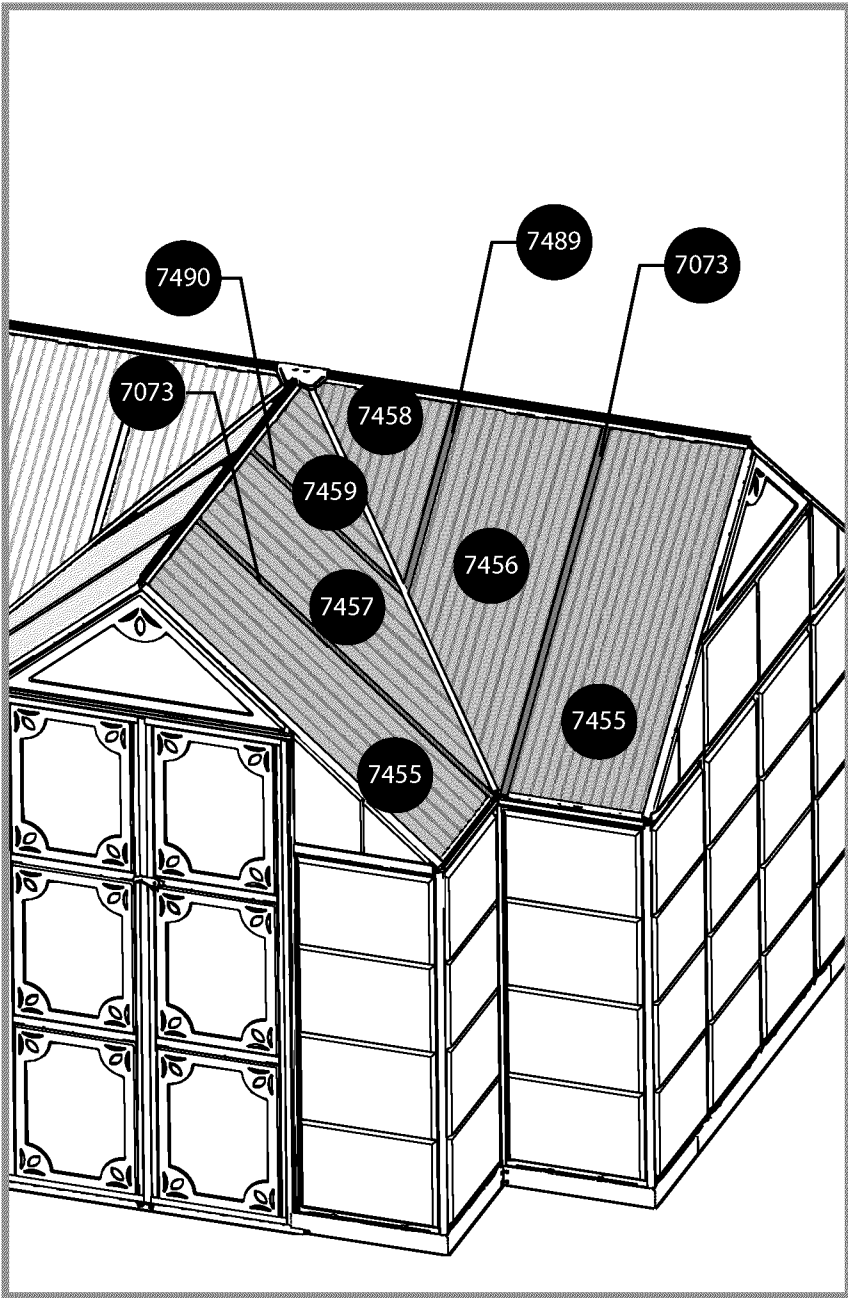
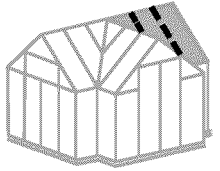

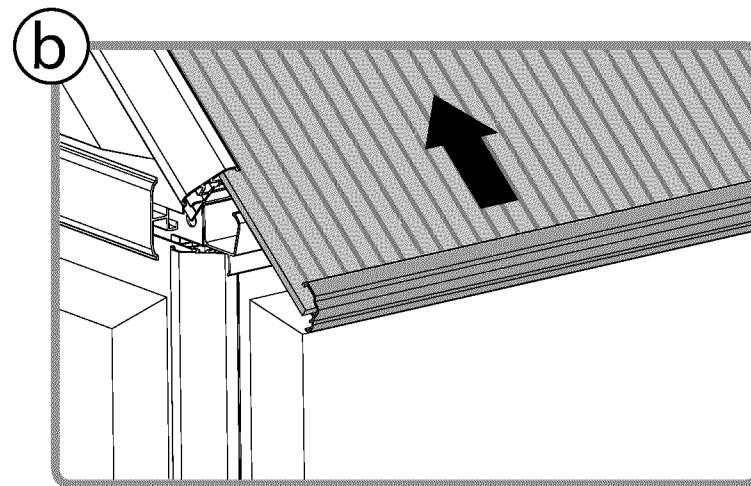
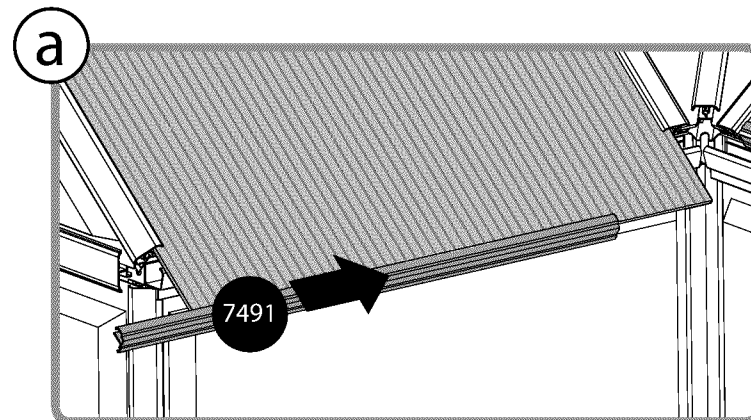
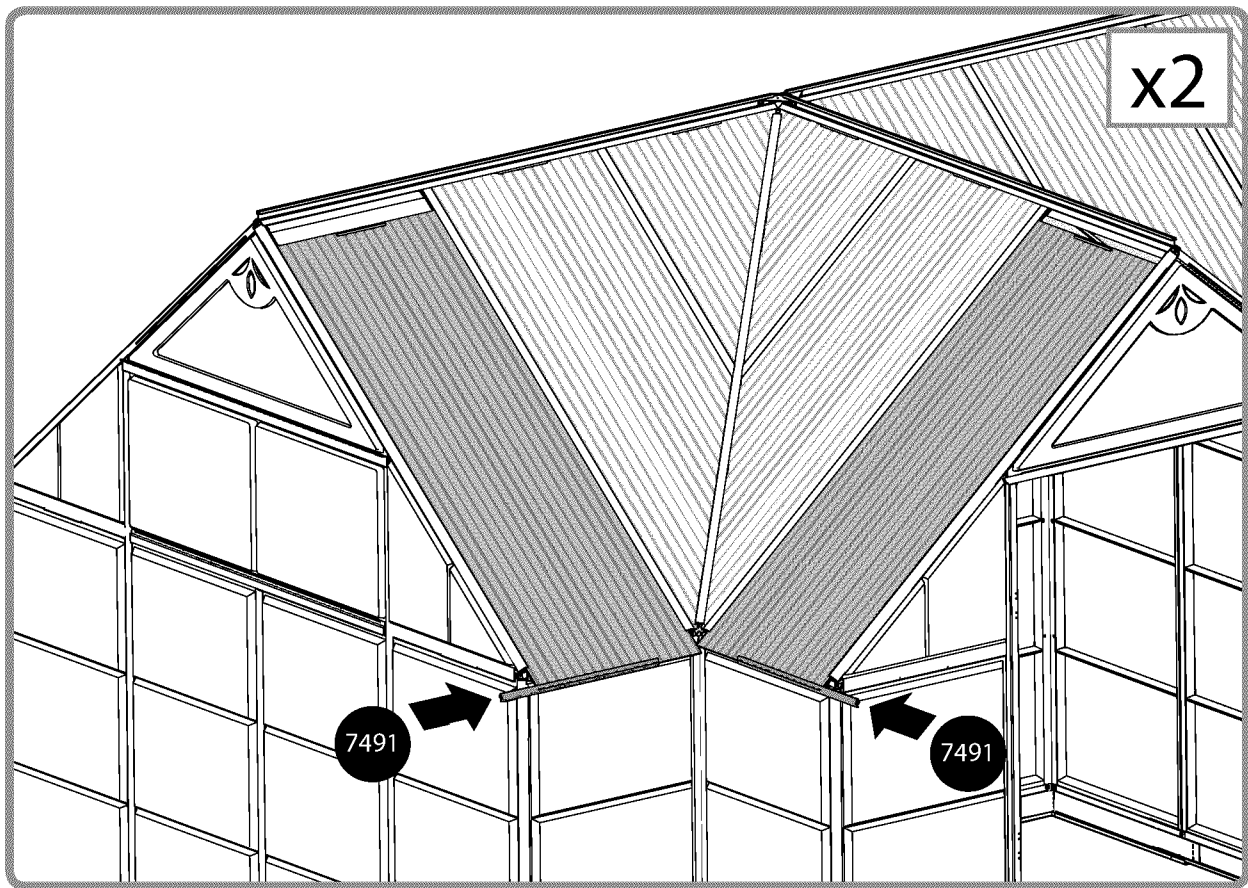
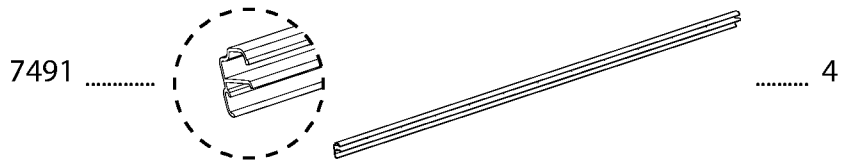
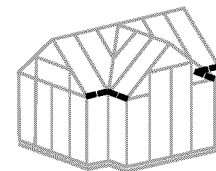

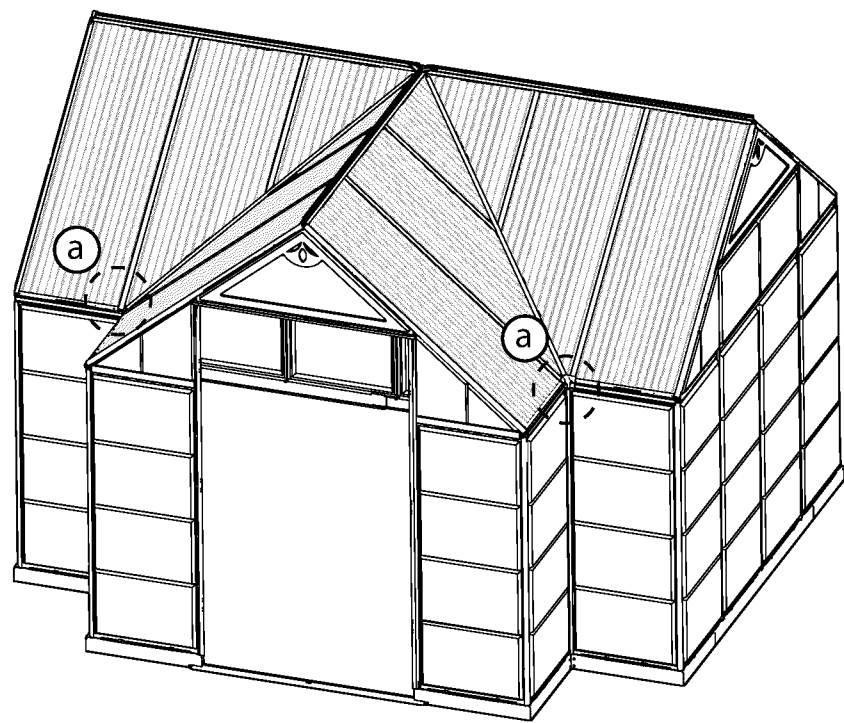
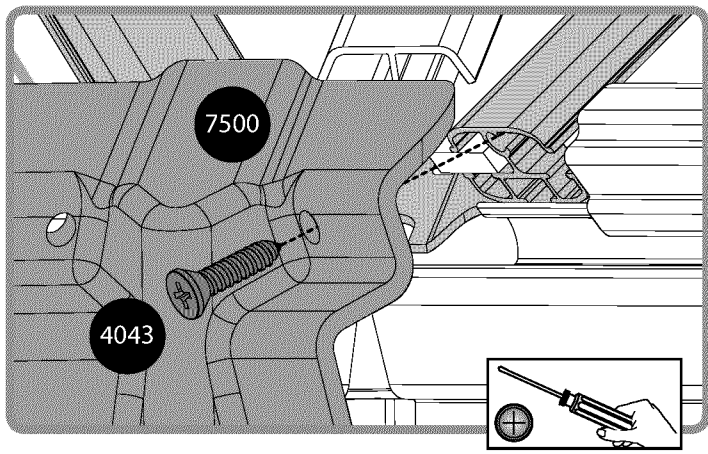
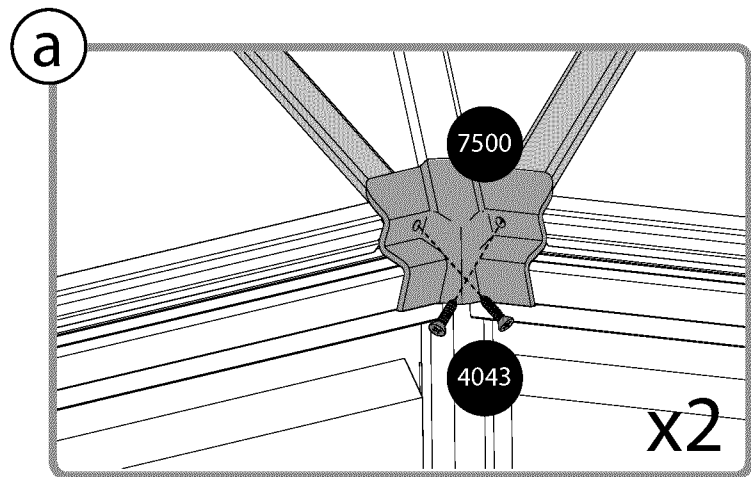
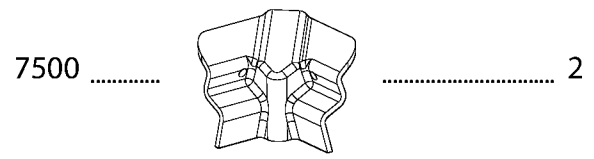
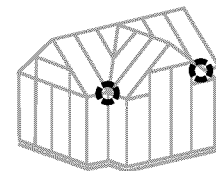

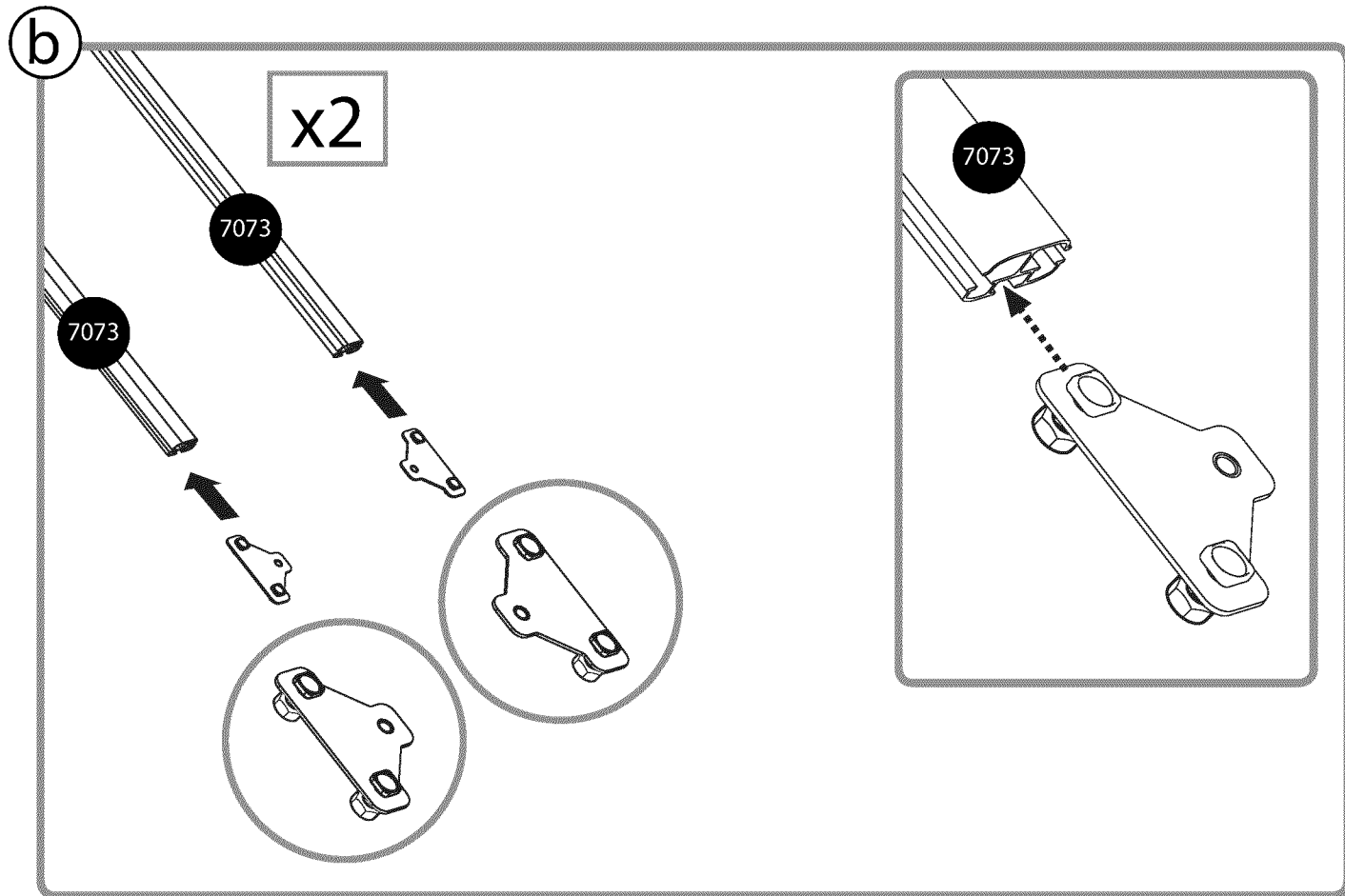
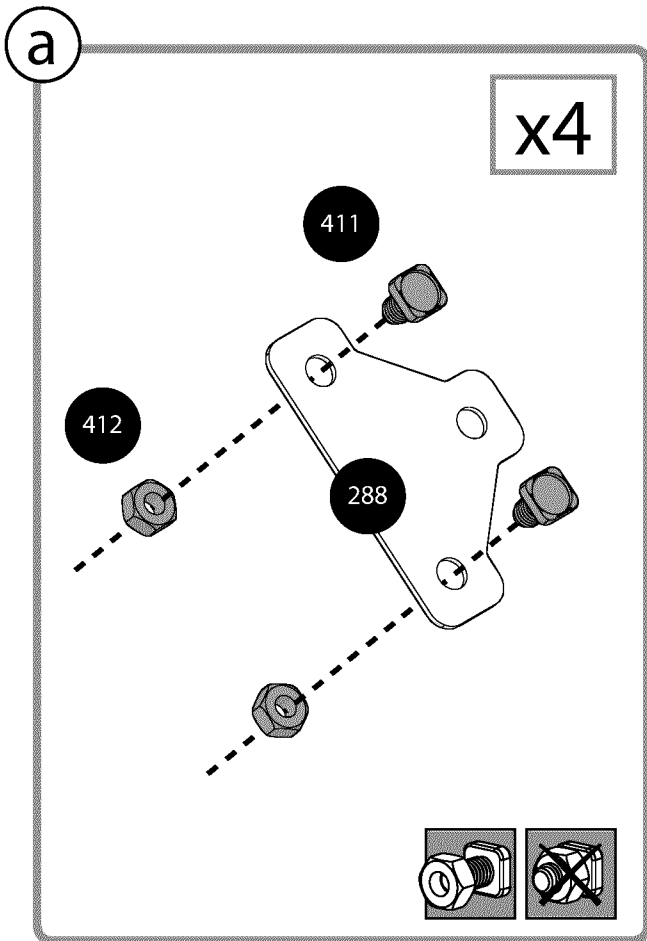
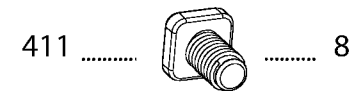
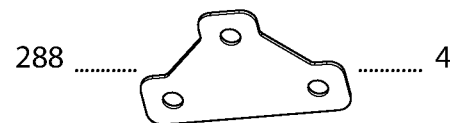
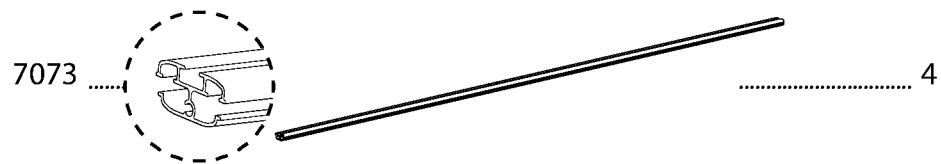
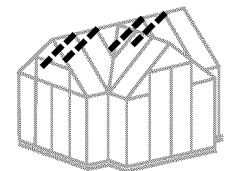

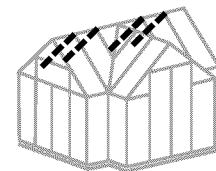

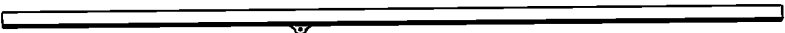
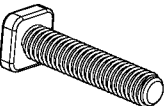



 2		7284	4	 4	411
 2				 4	412

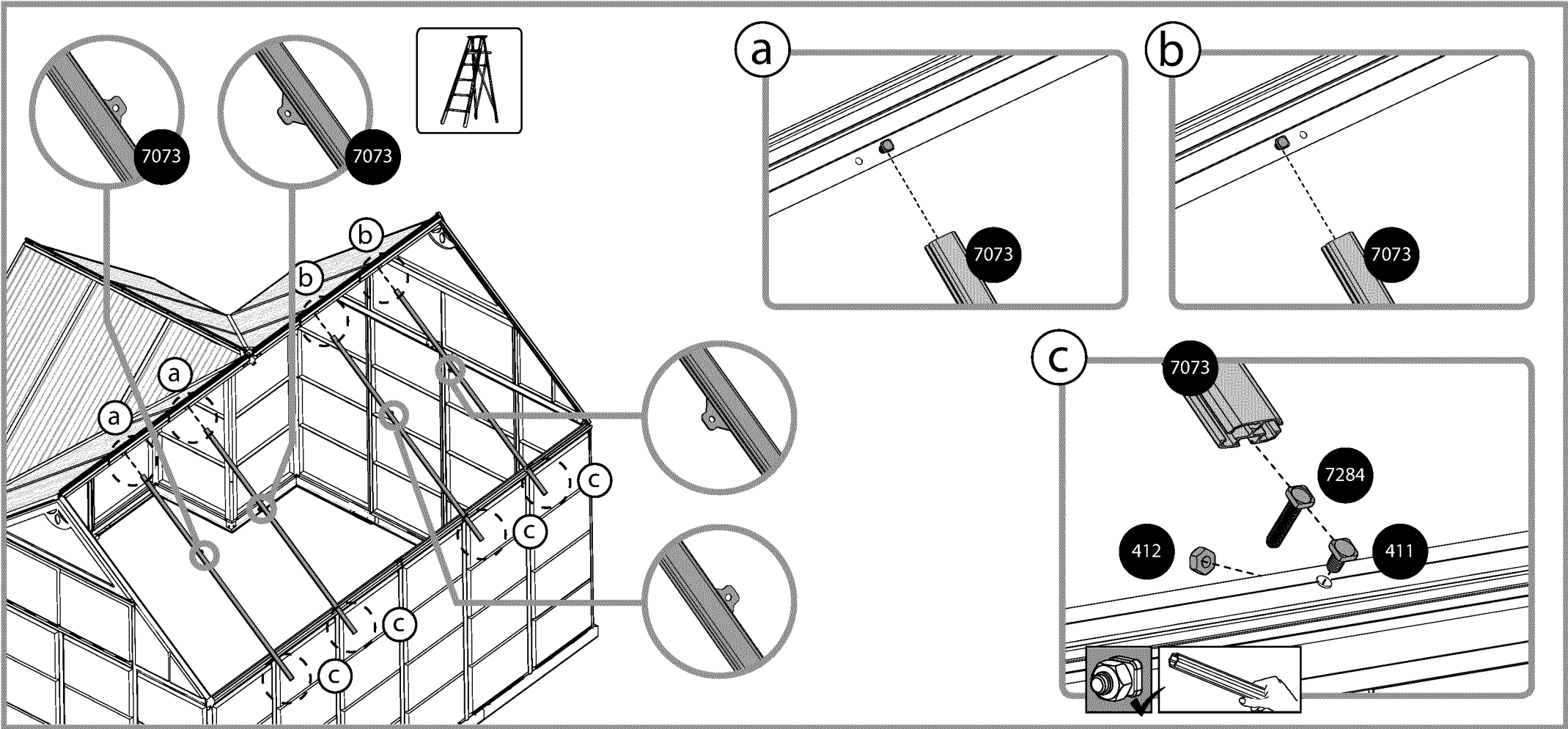

a

b

c

7073

7073

7073

7073

7284

412

411

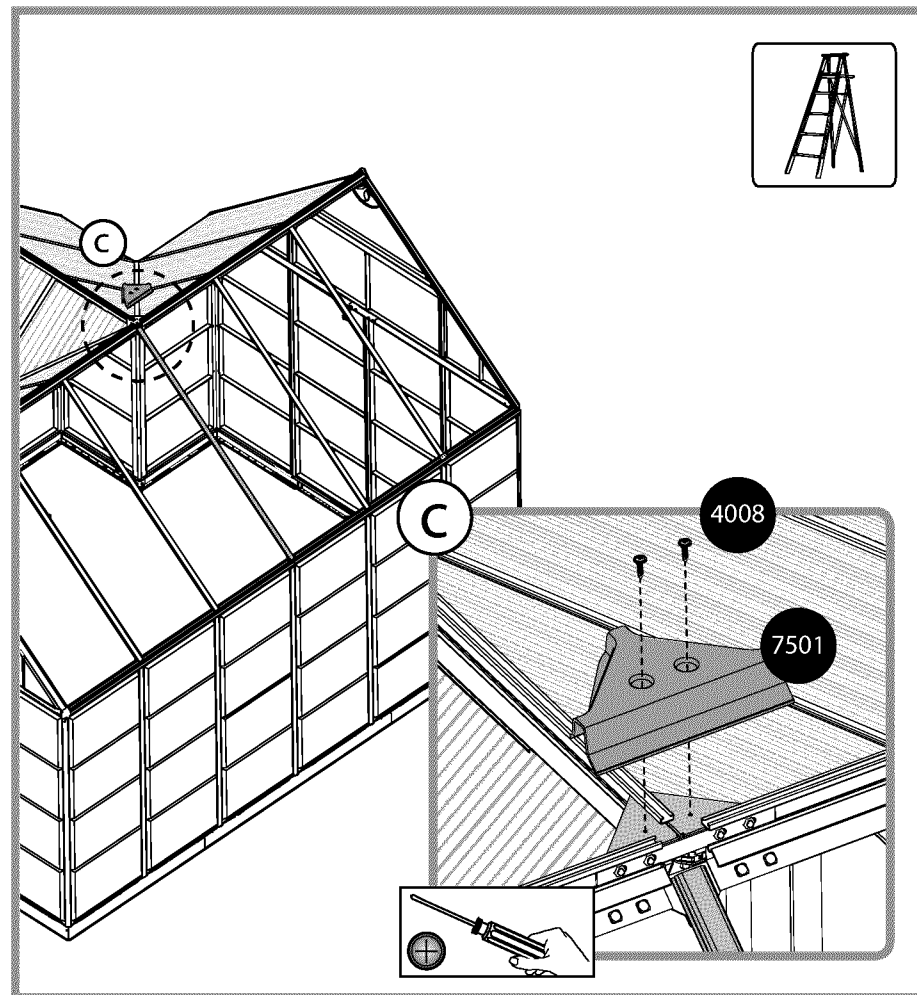
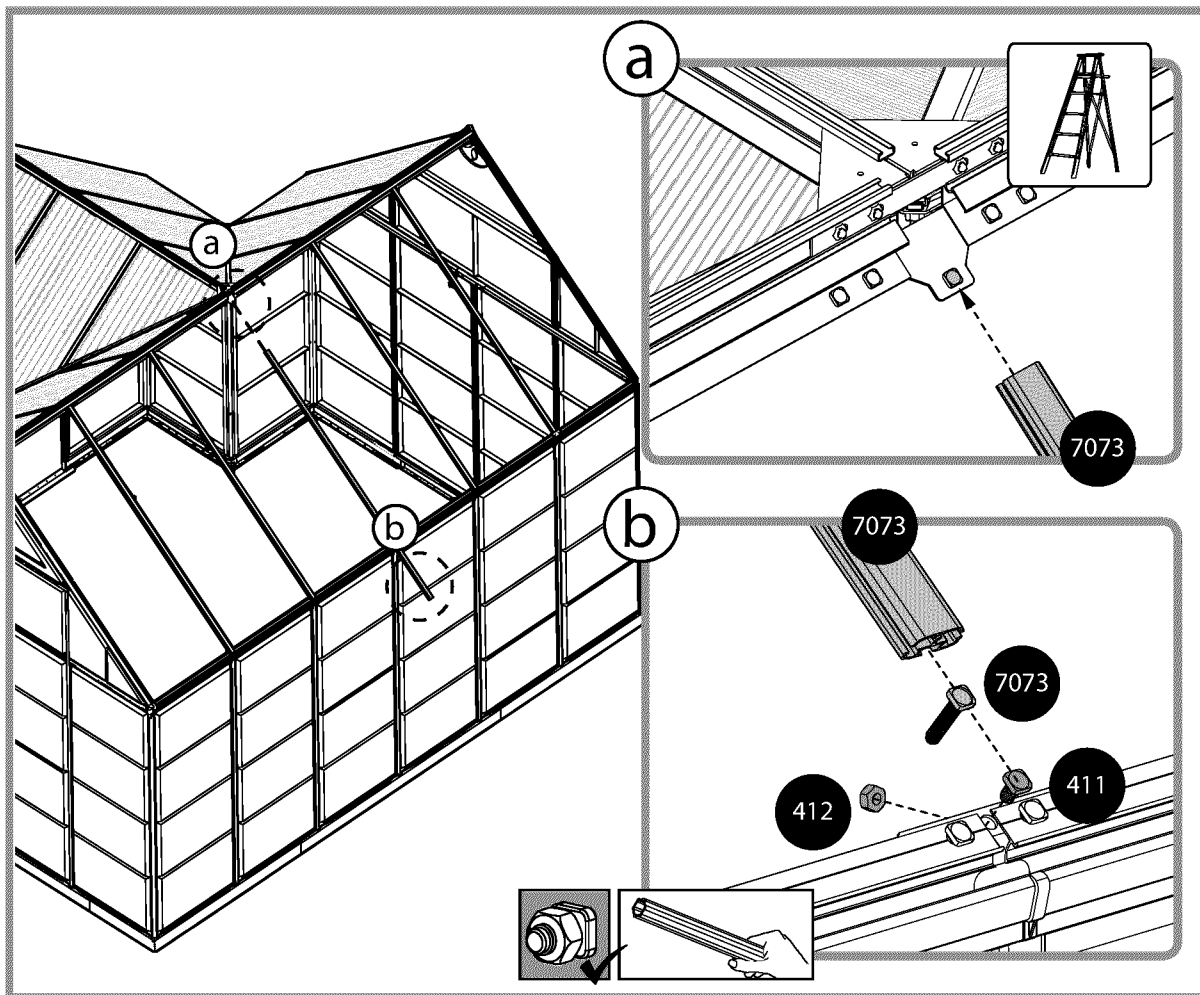
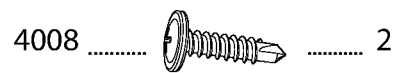
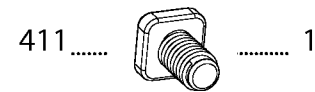
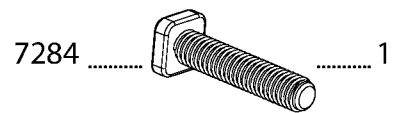
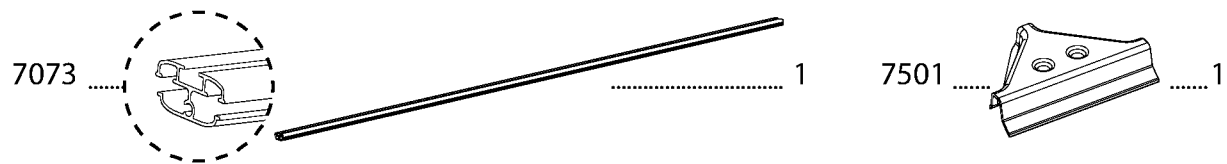
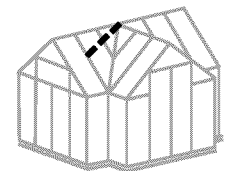

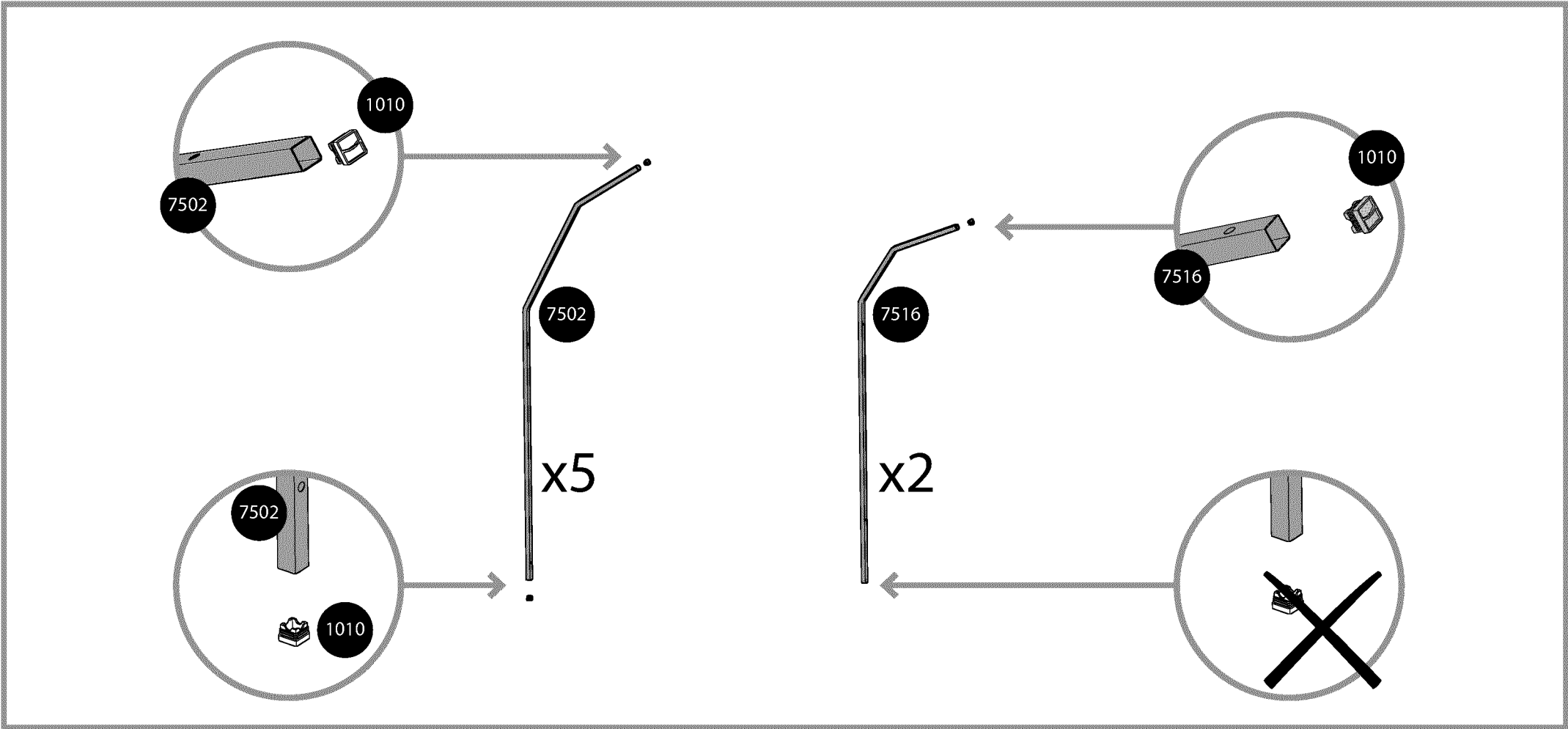
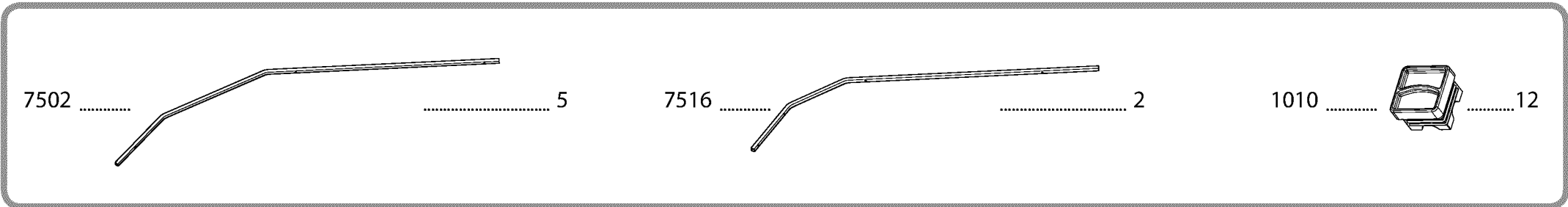
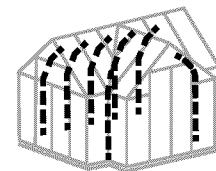

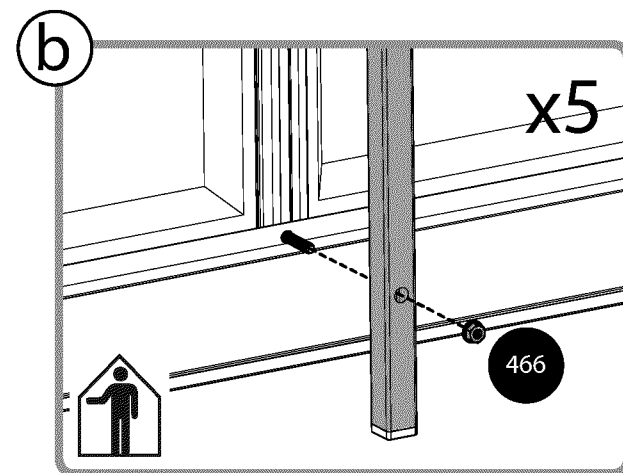
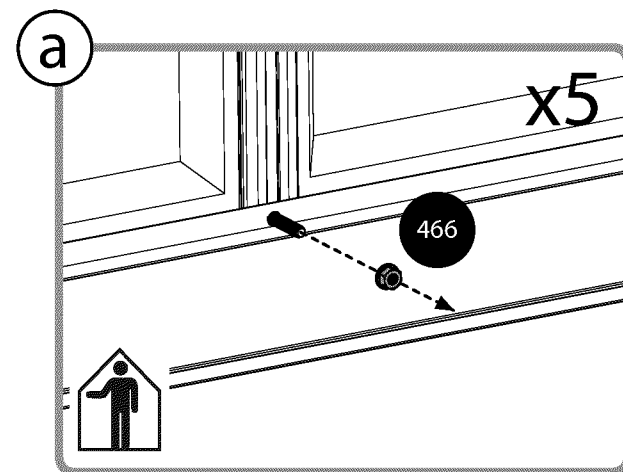
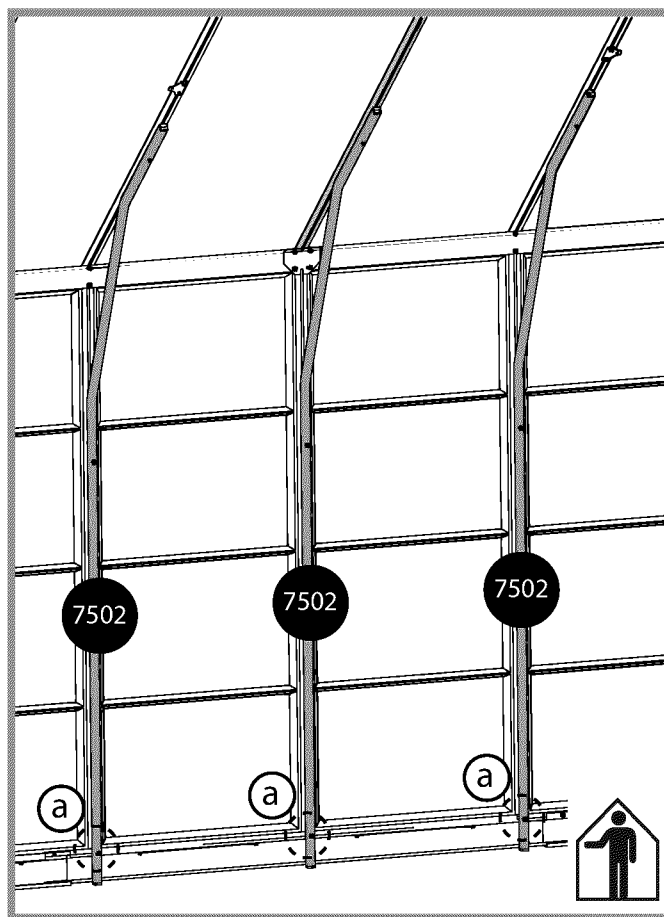
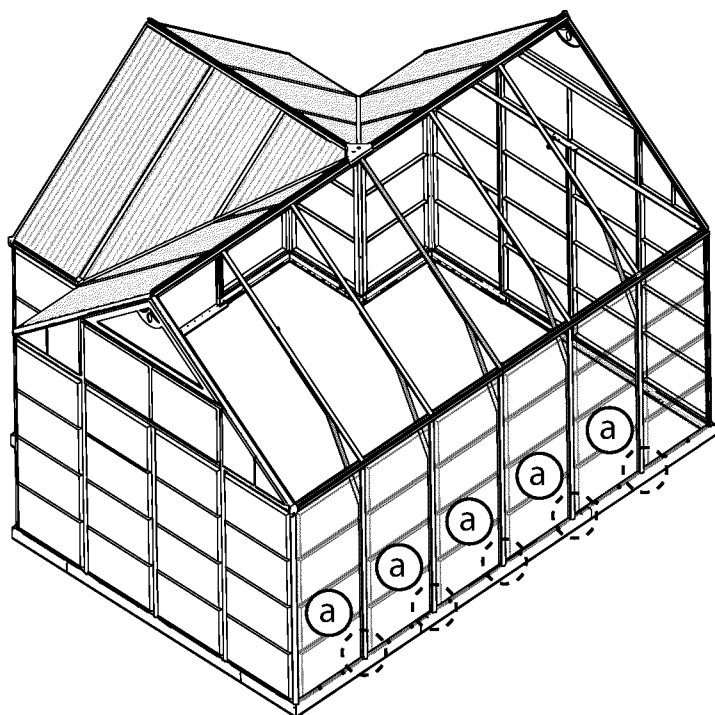
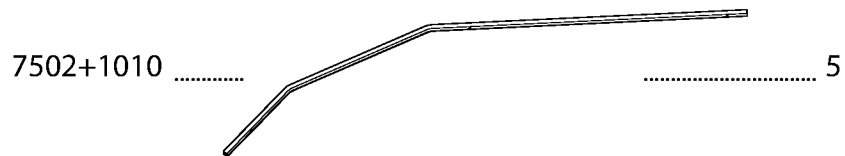
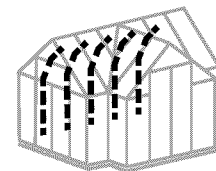

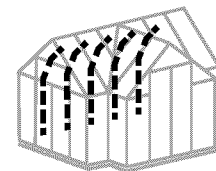

466 10

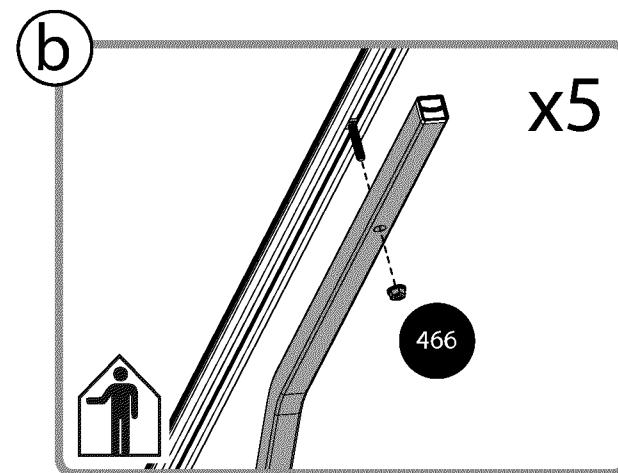
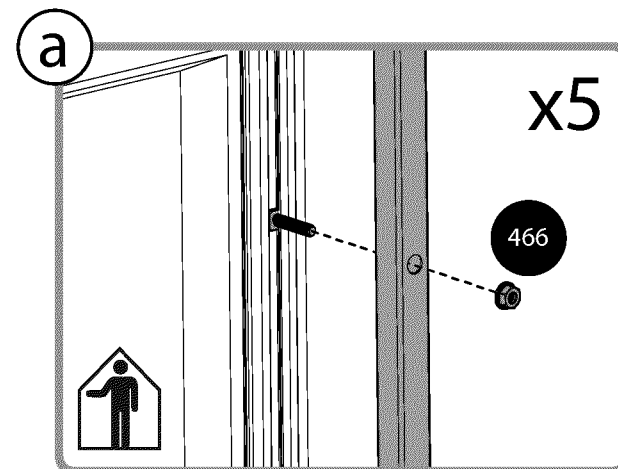
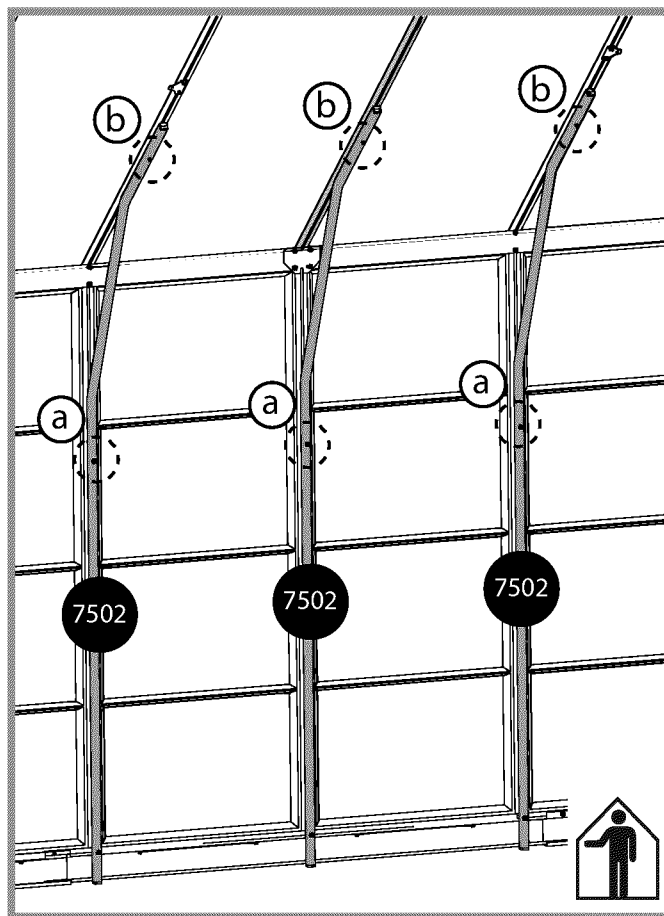
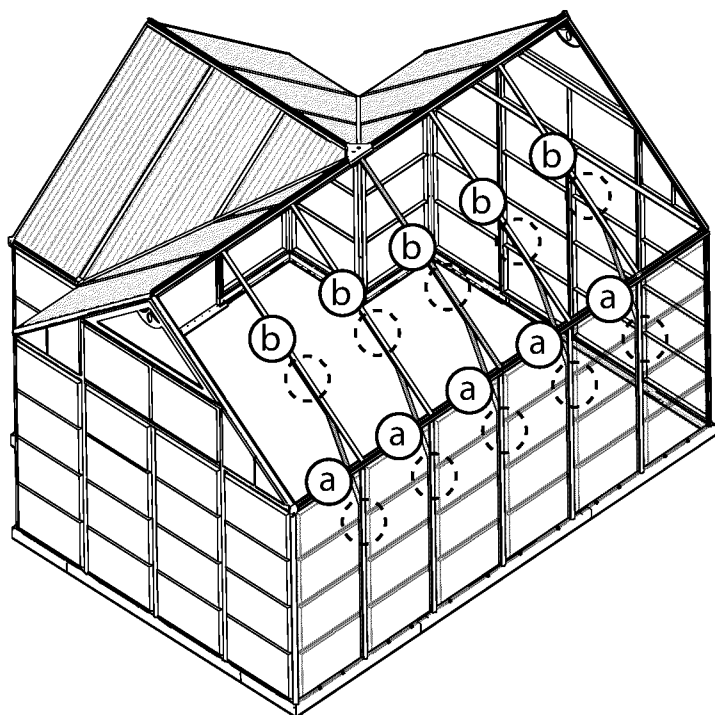

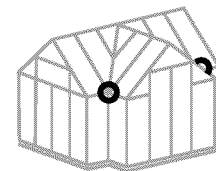

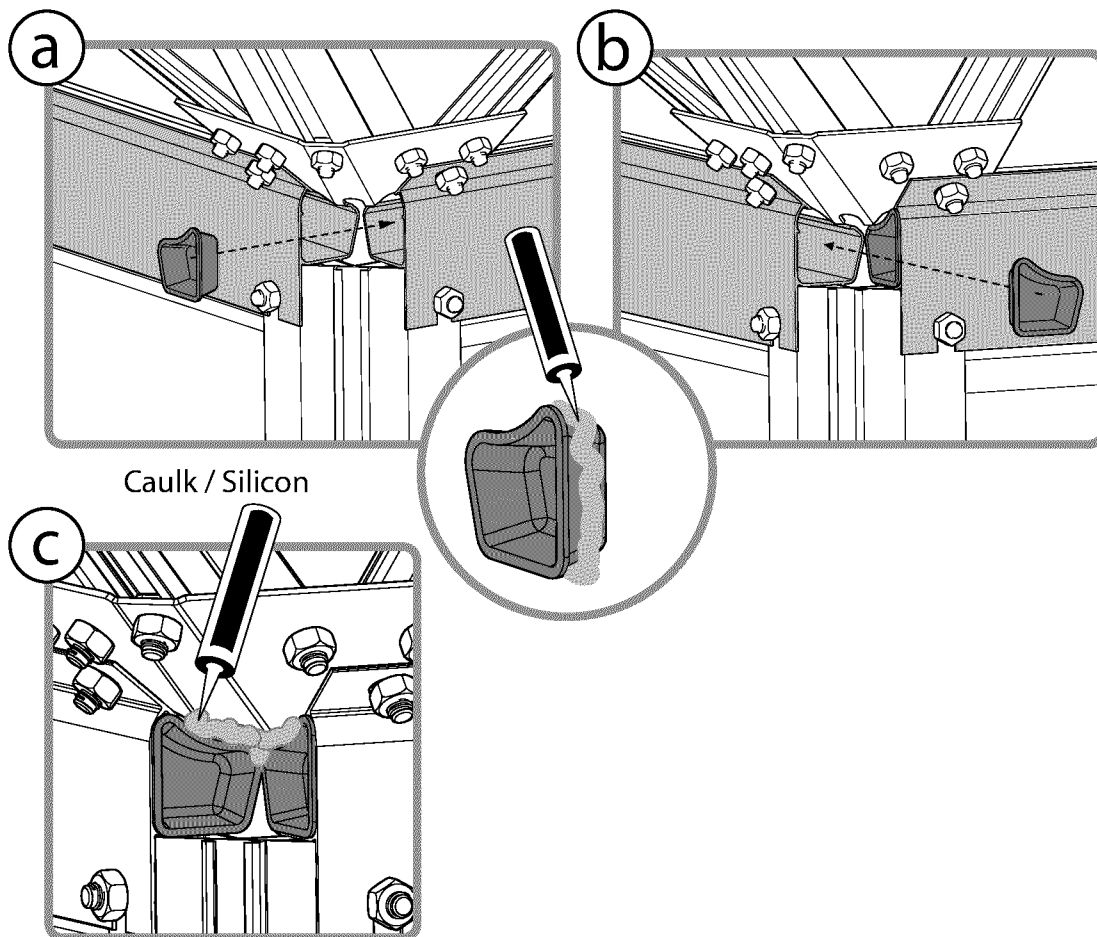
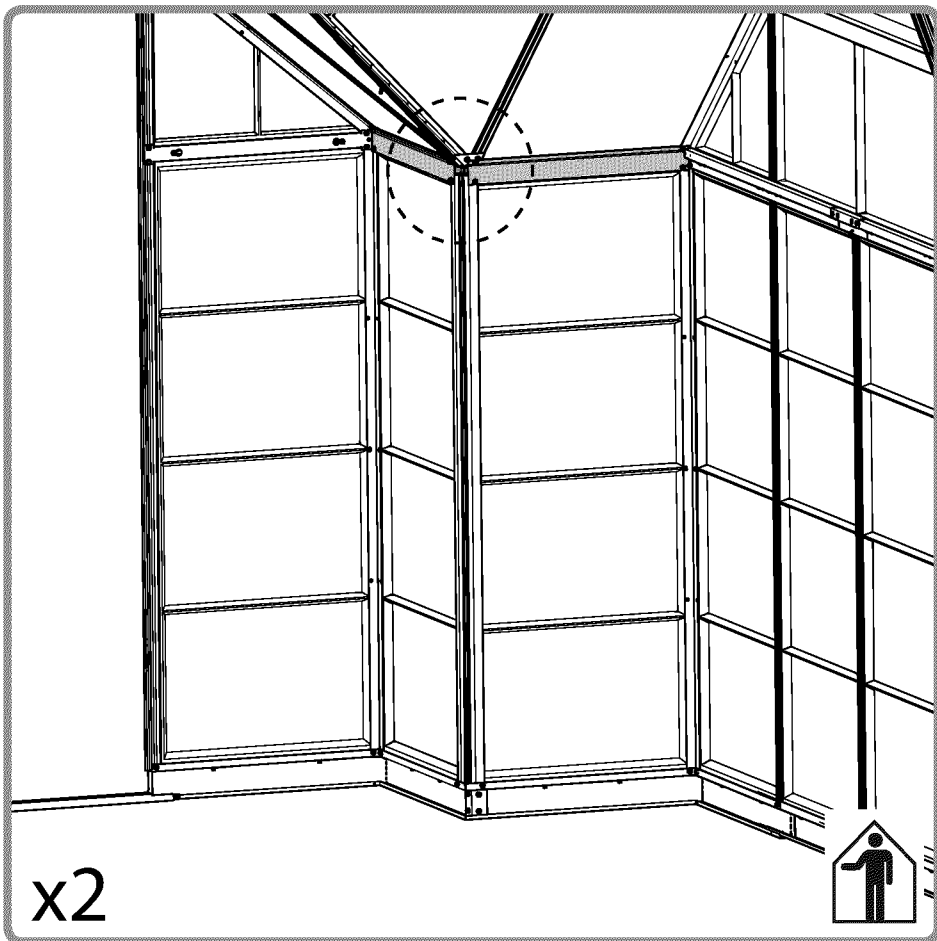
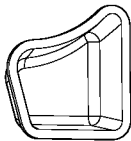
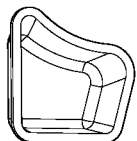

7581 2 7582 2

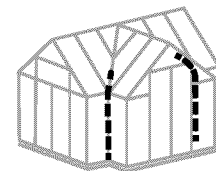

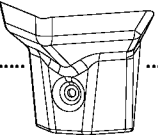
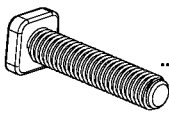

7516 + 1010	 2	7520	 2	7284	 4	411	 2
						466	 10			

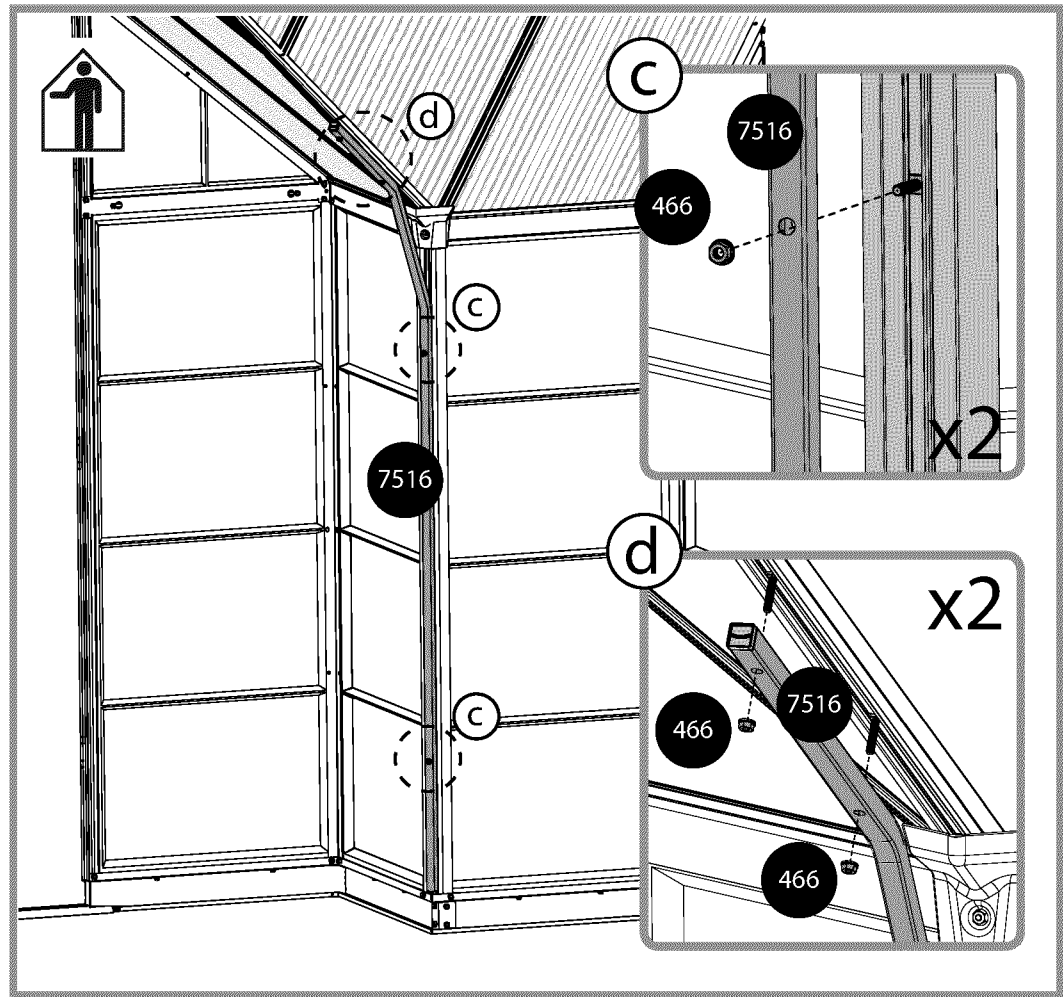
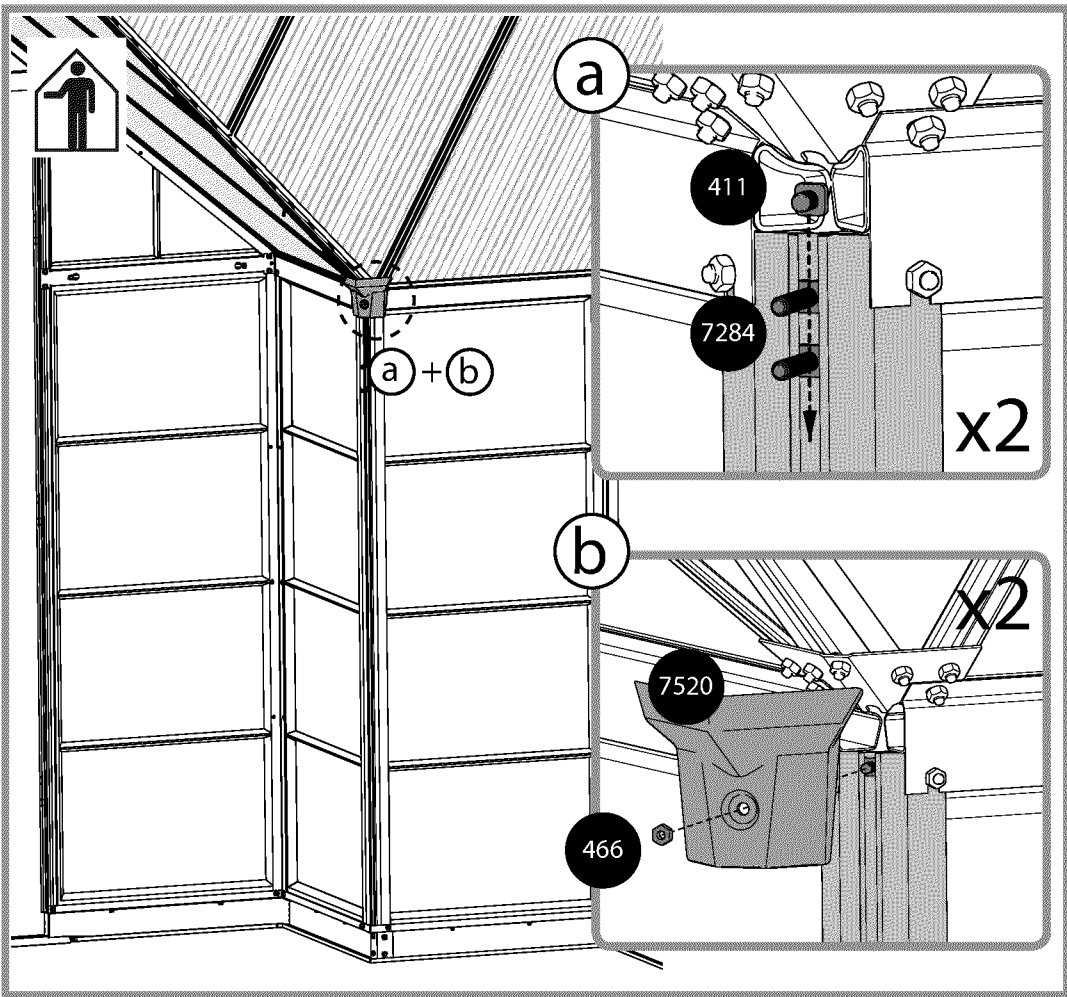

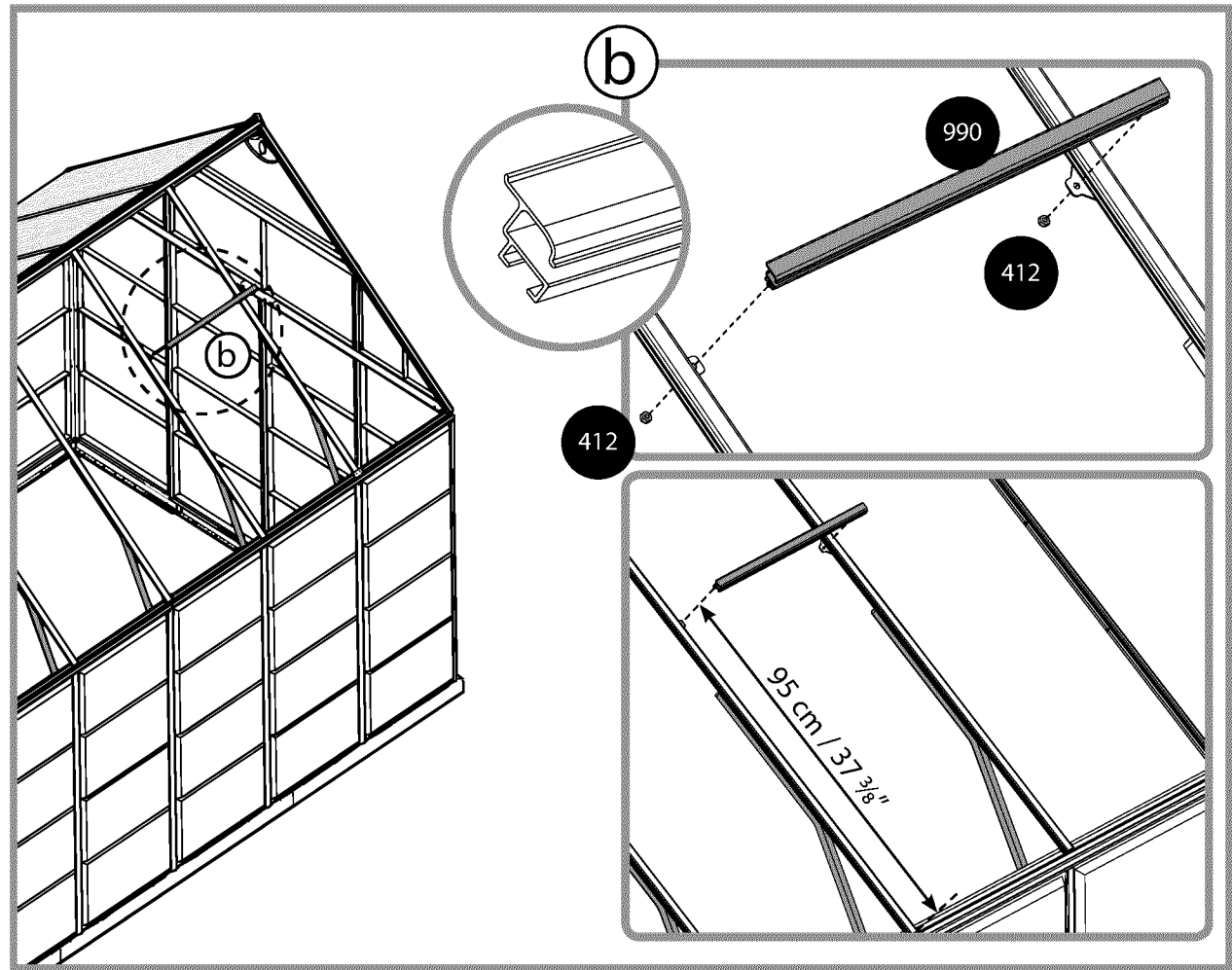
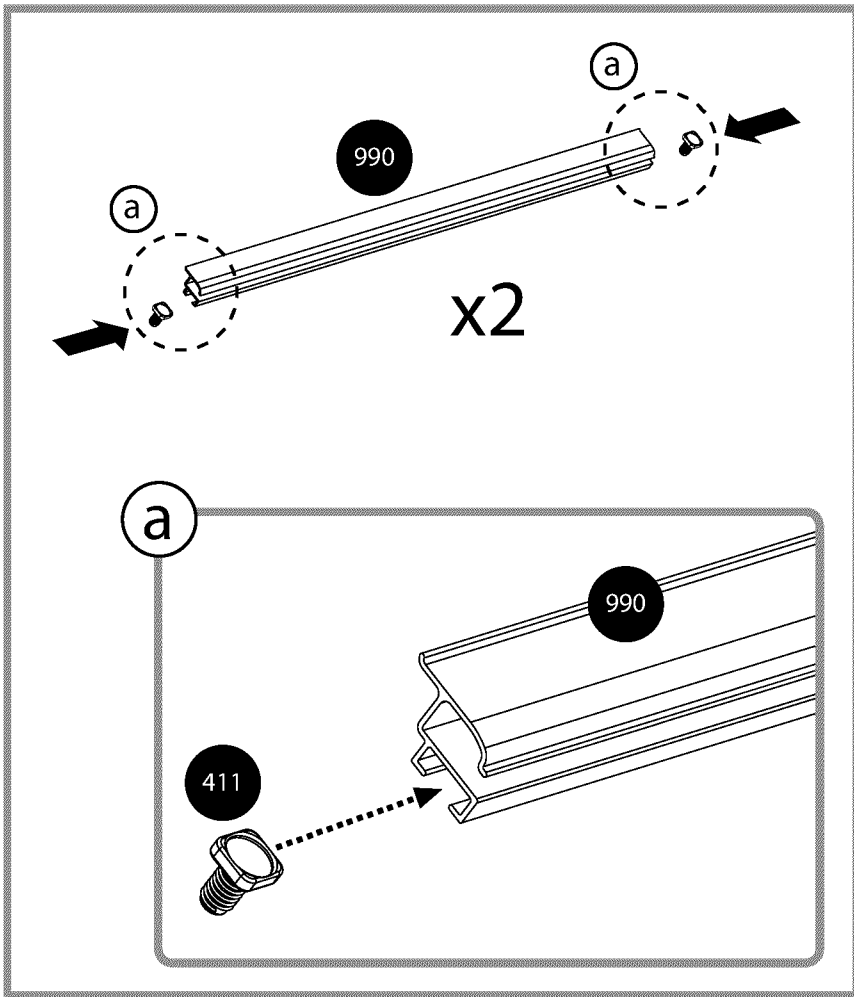
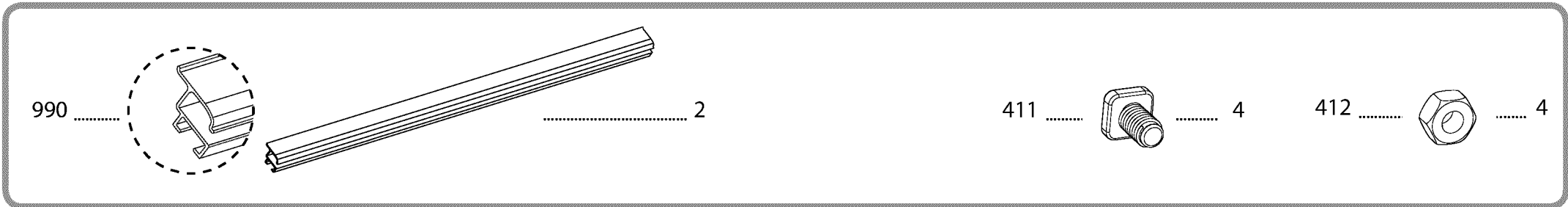
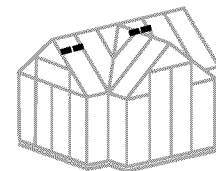

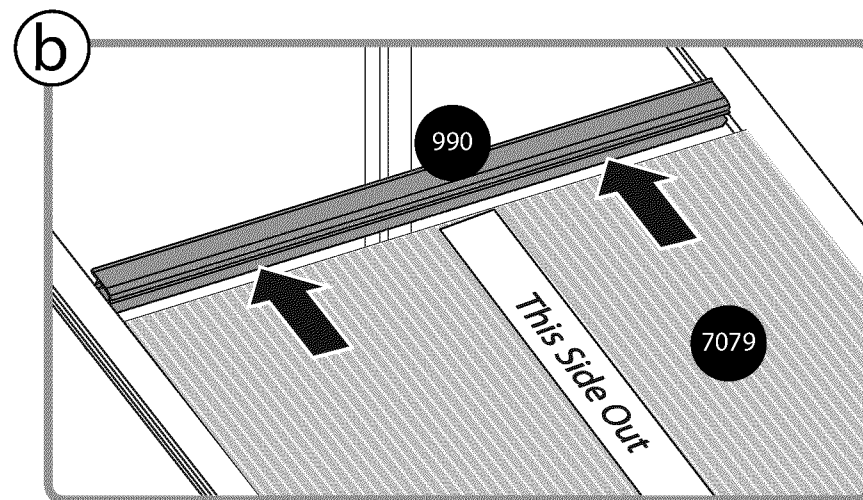
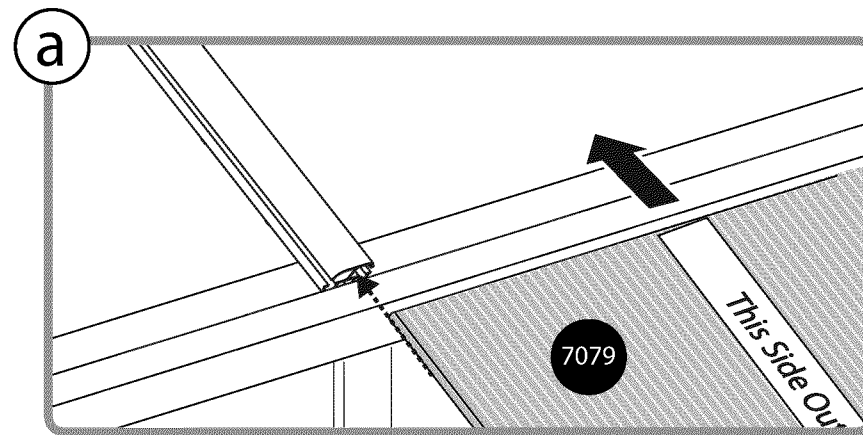
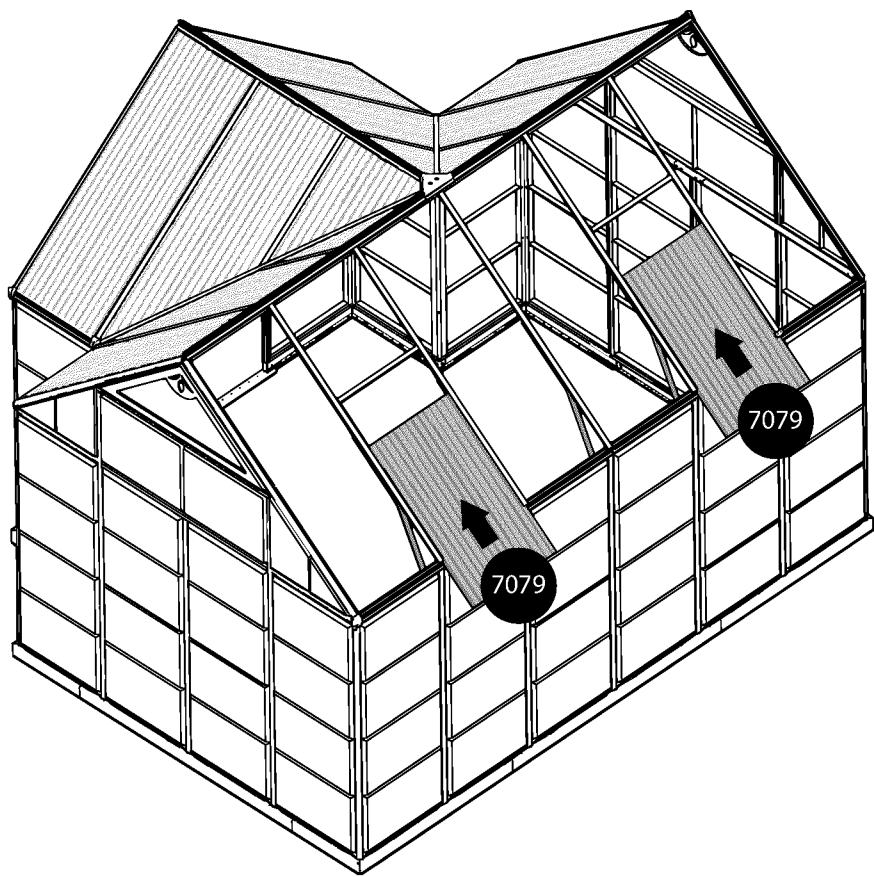
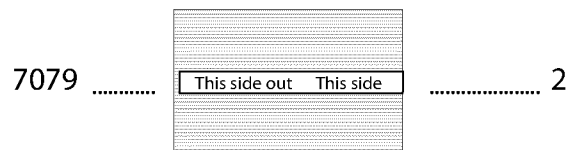
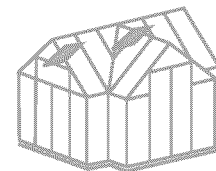

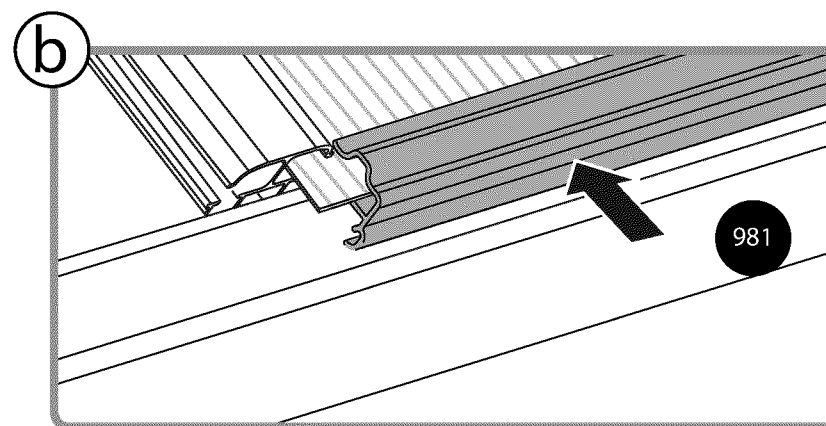
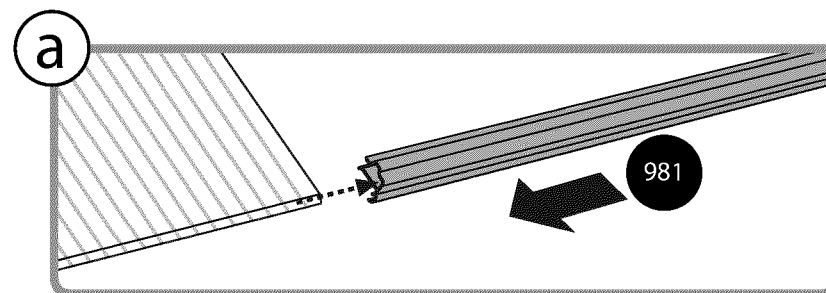
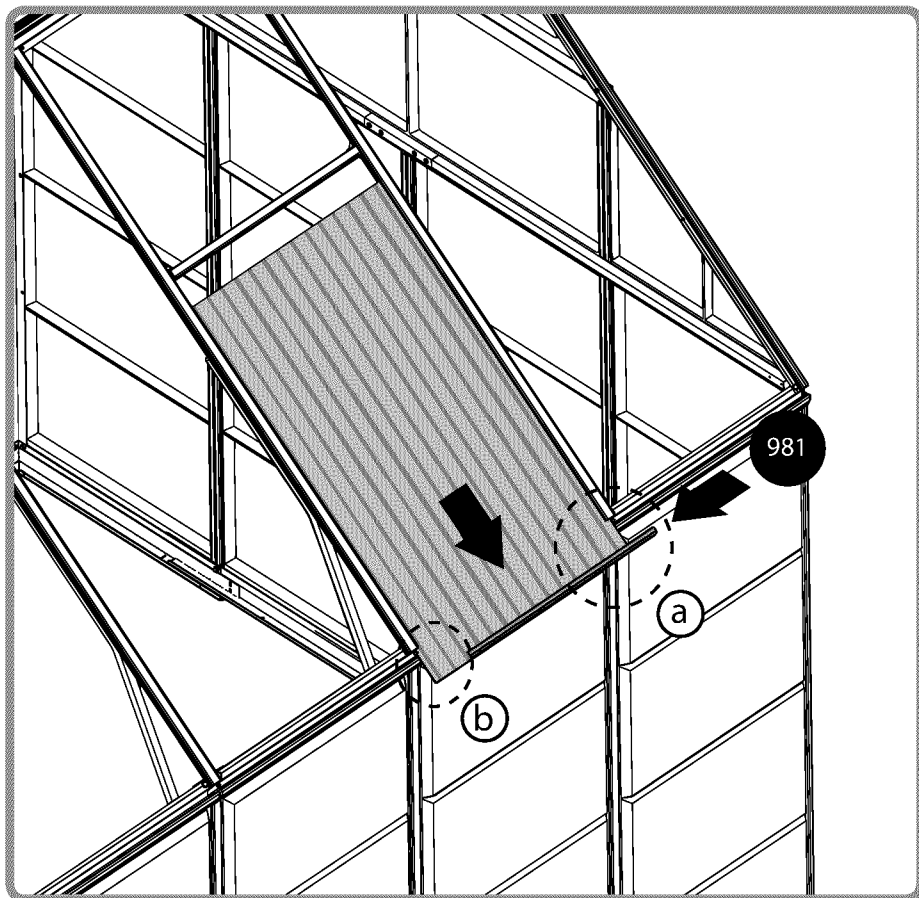
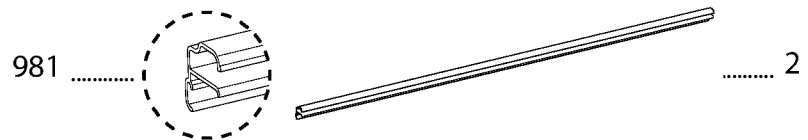
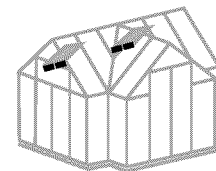

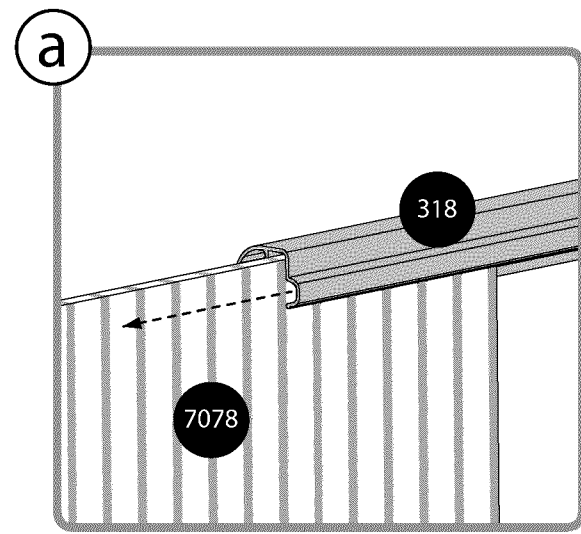
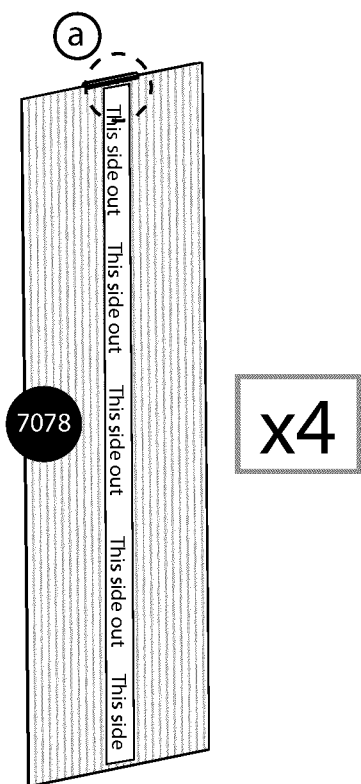
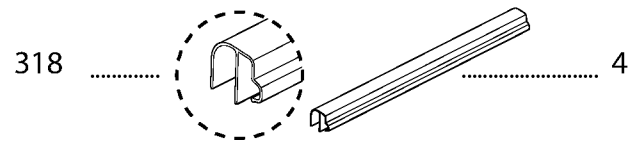
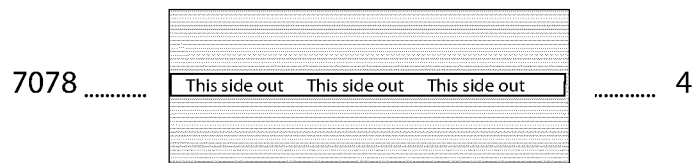
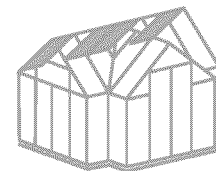

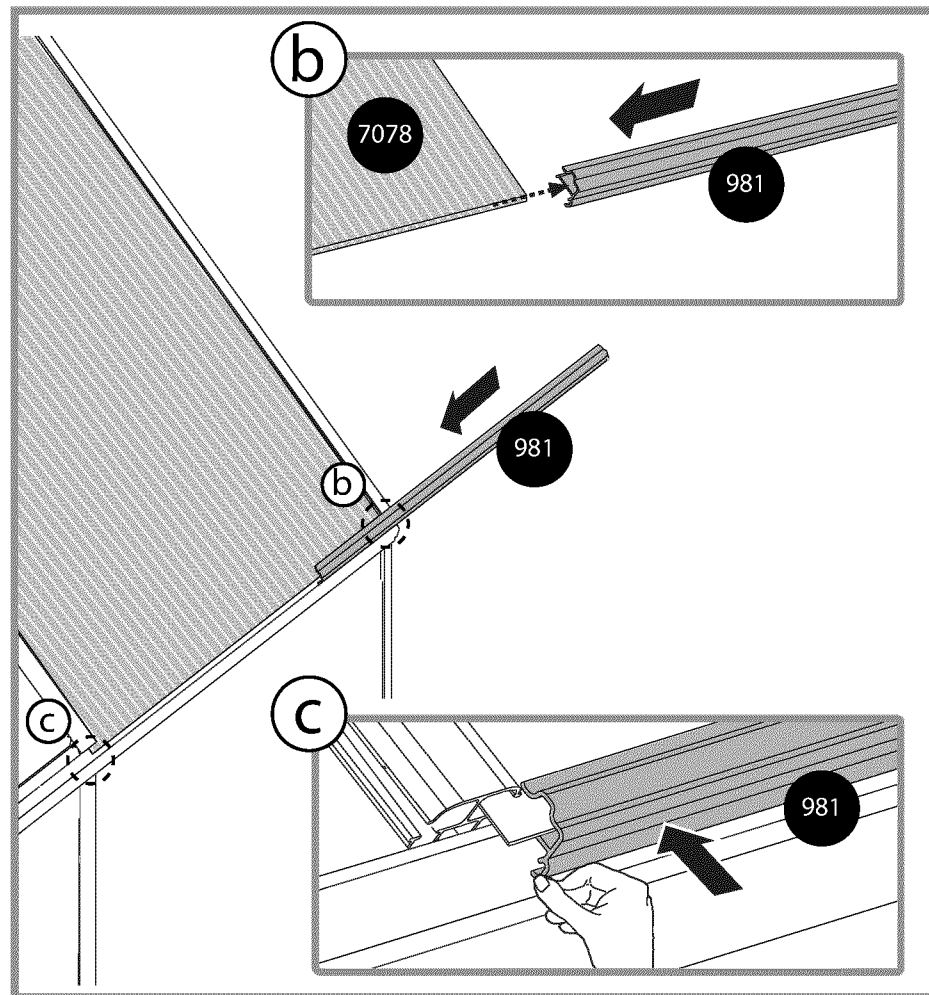
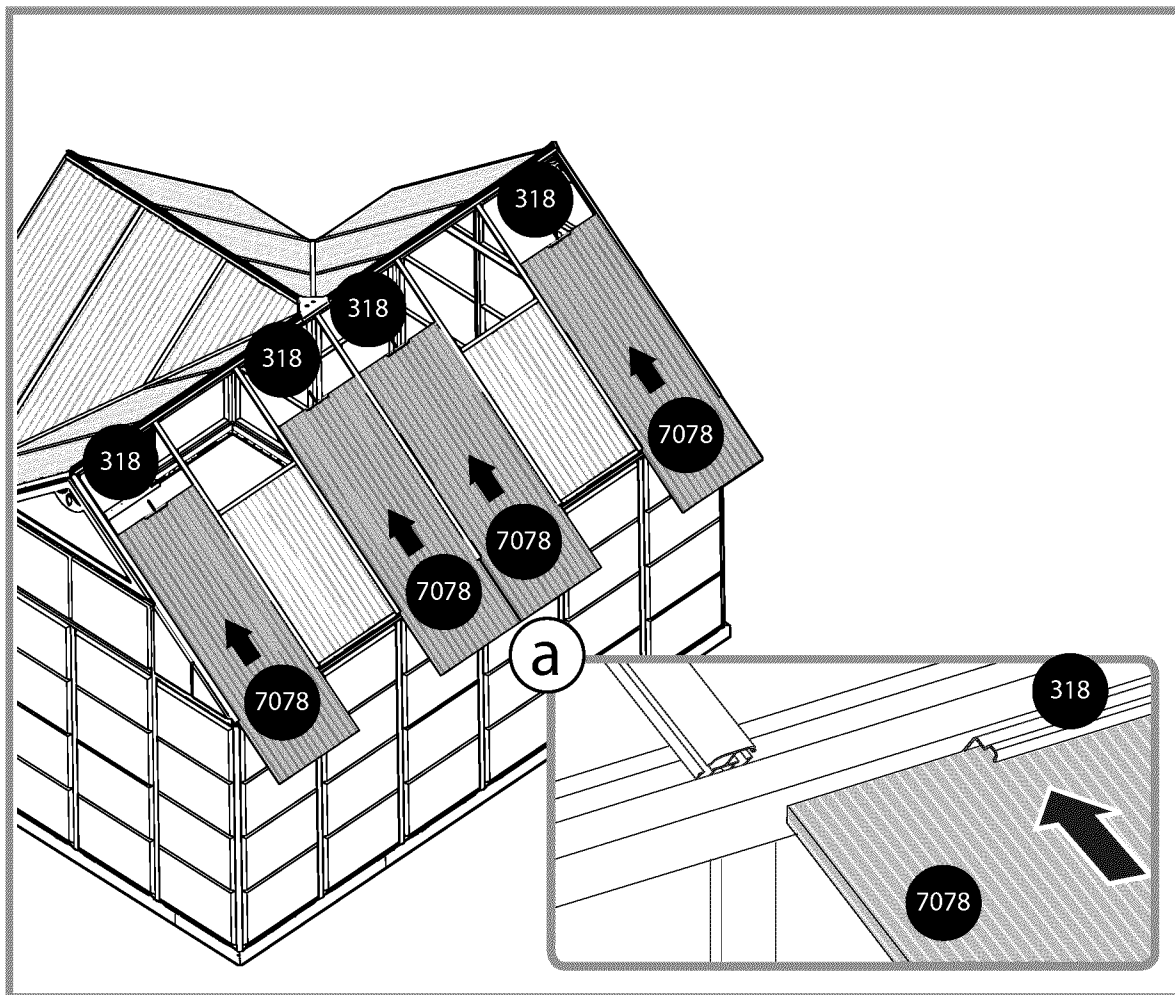
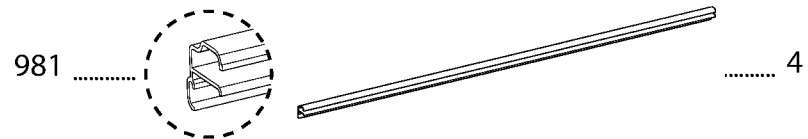
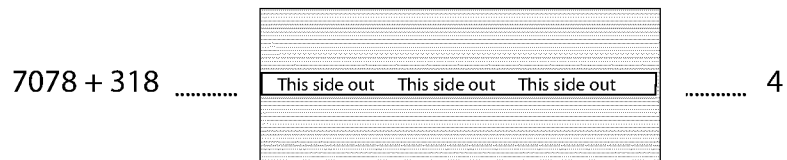
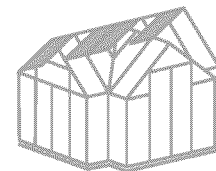

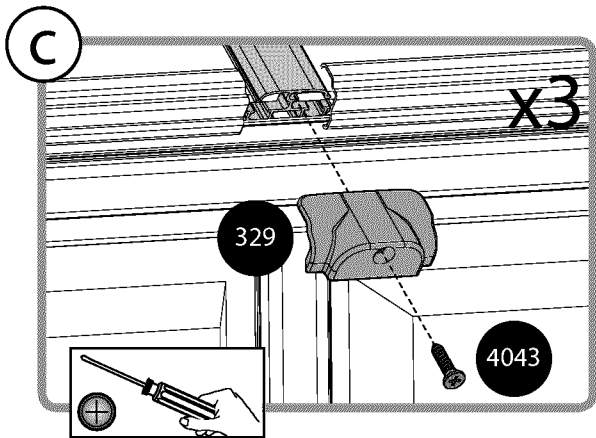
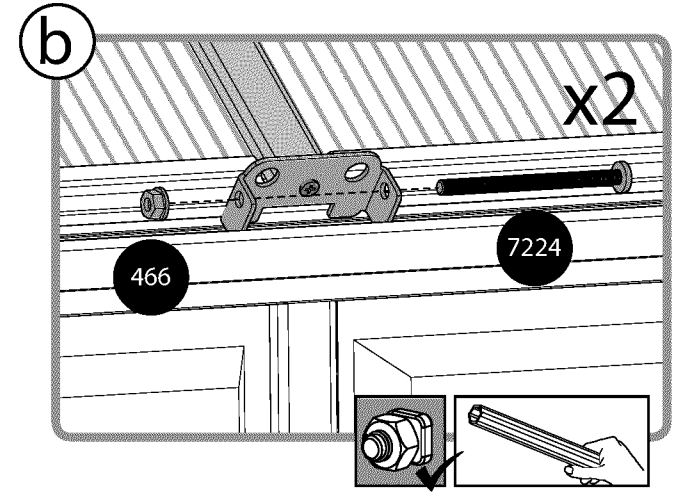
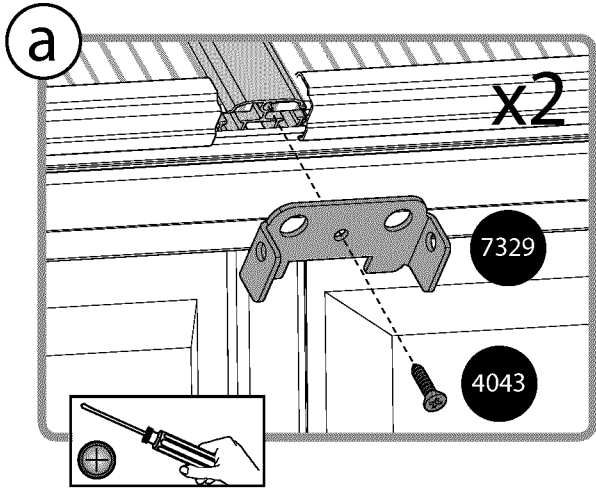
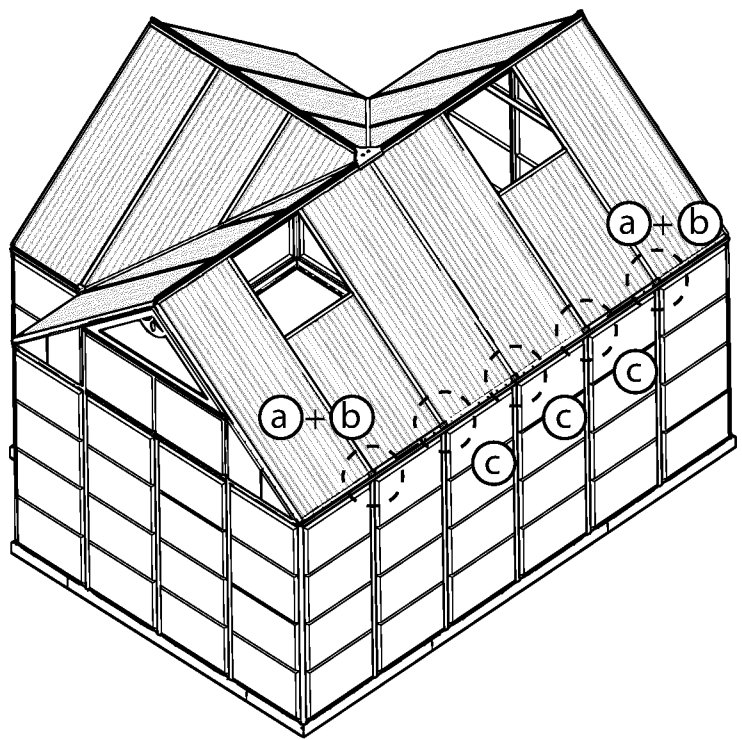
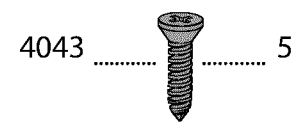
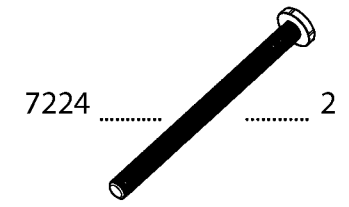
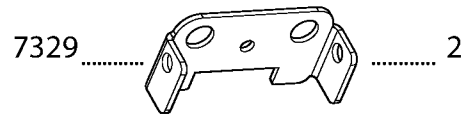
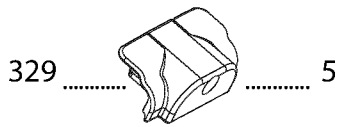
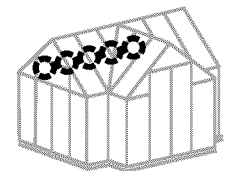

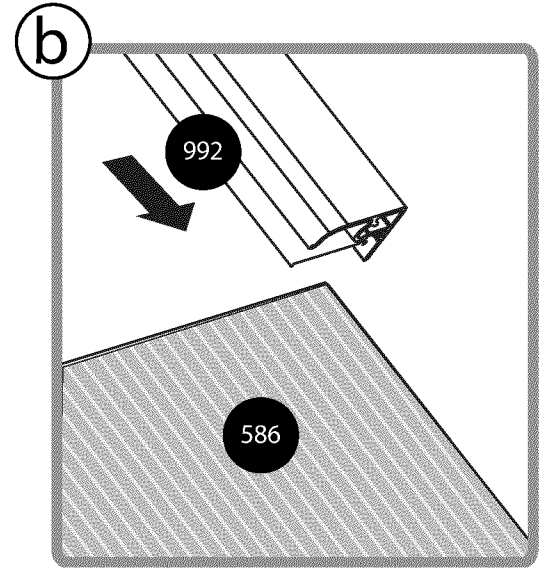
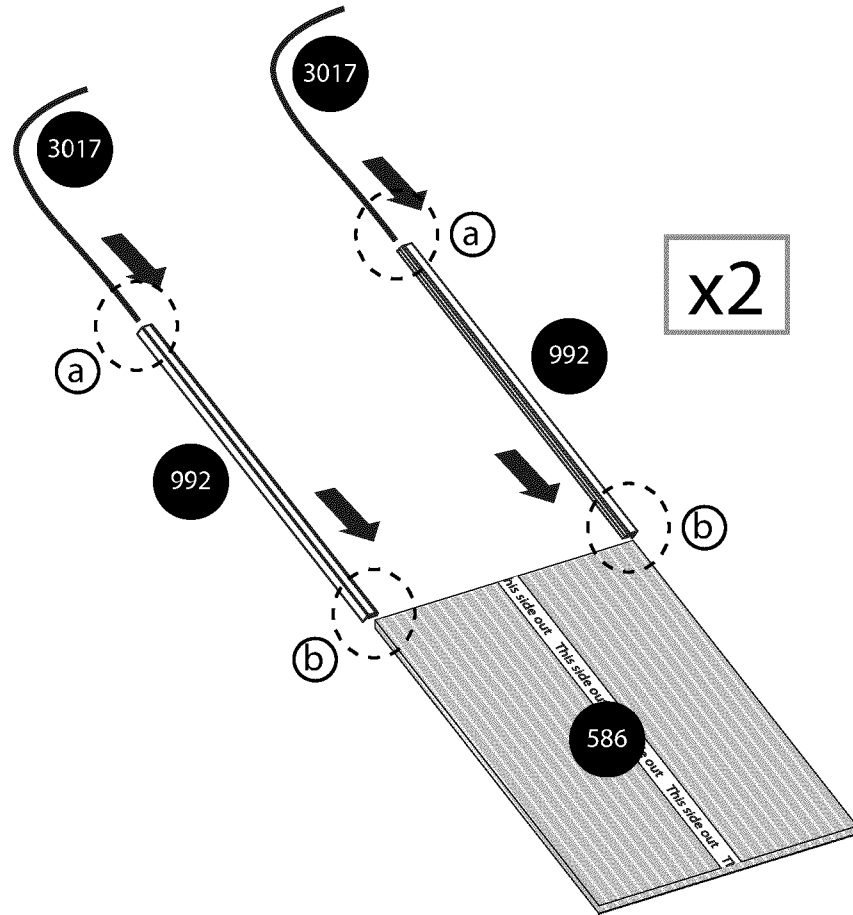
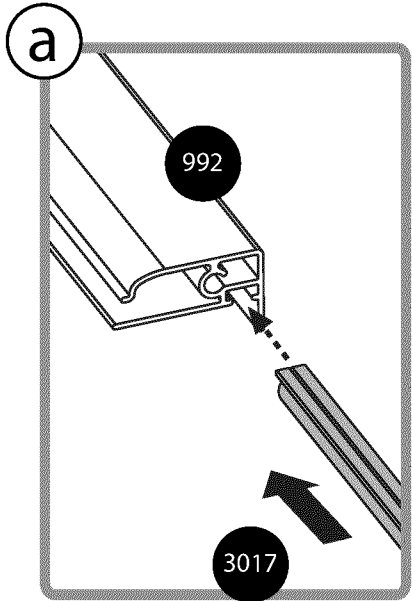
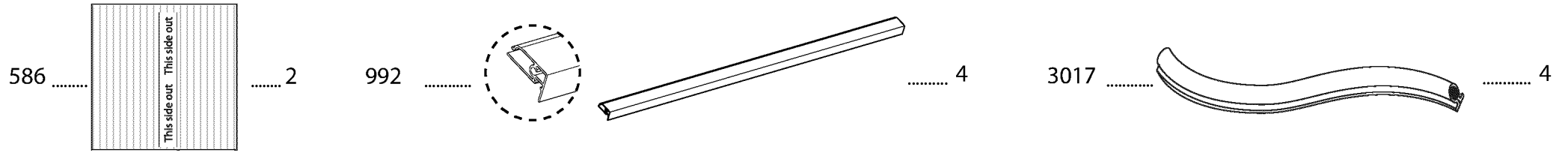
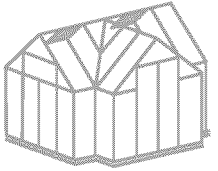

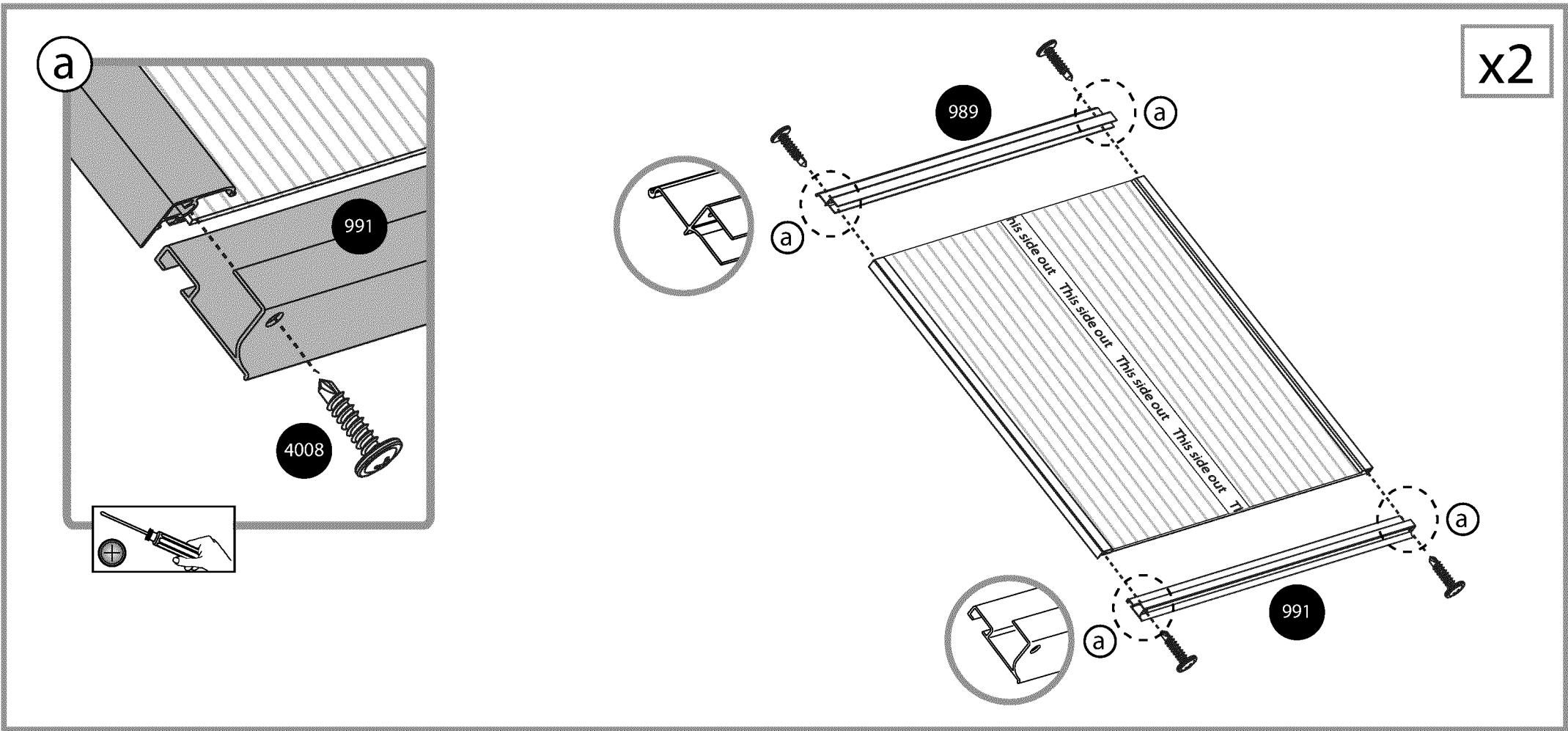
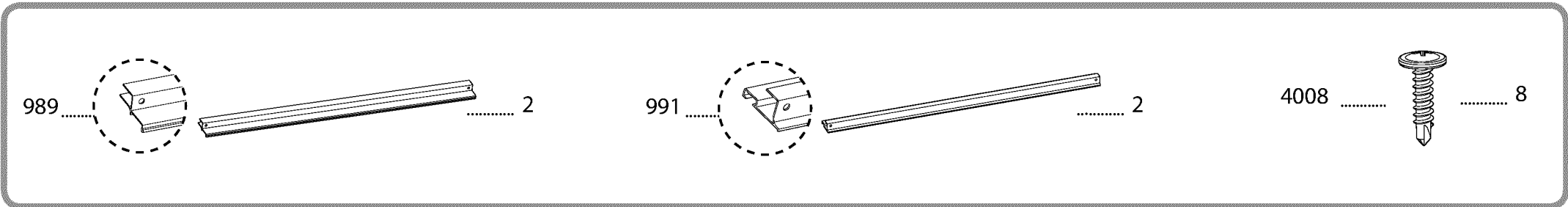
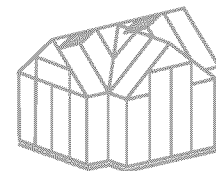

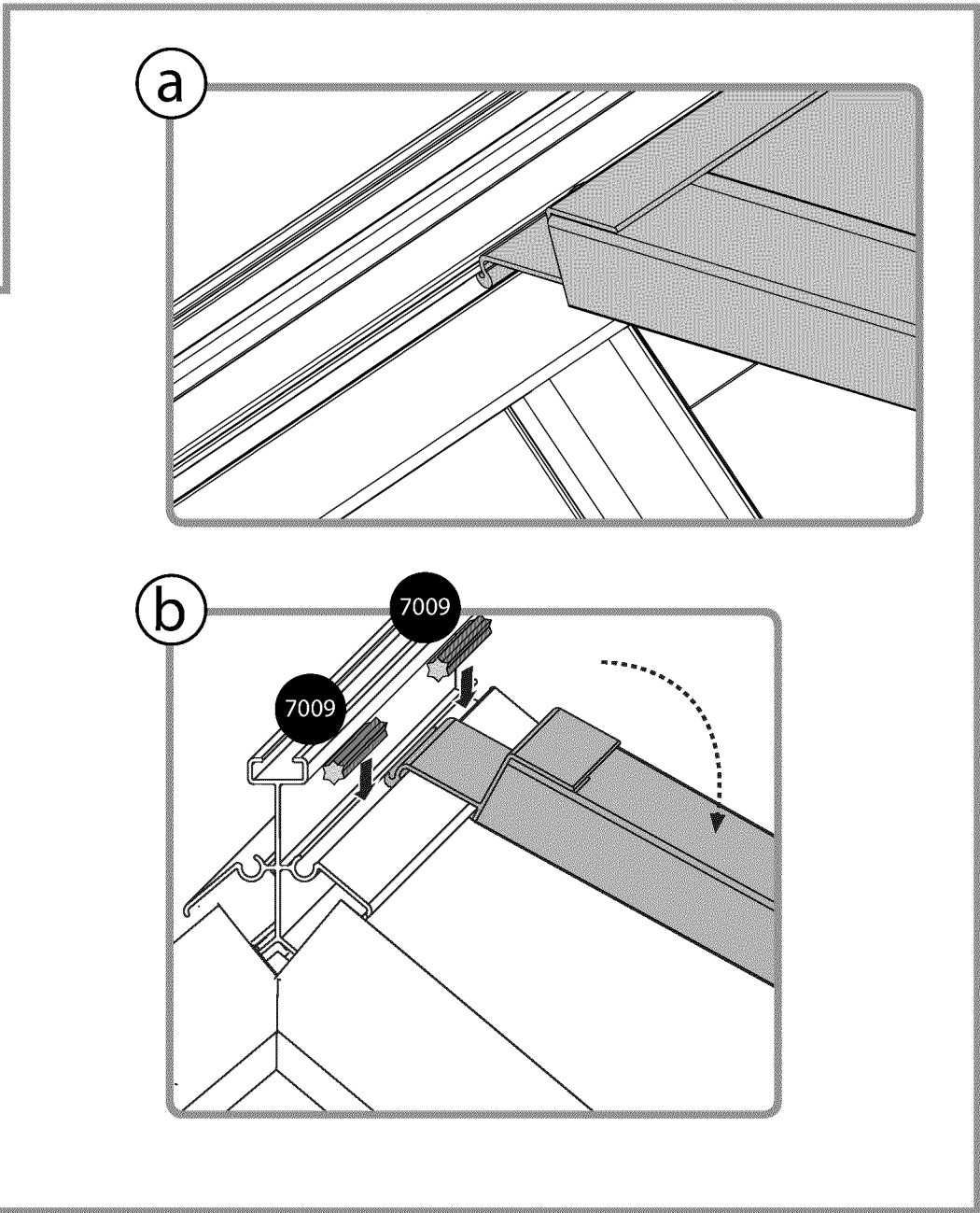
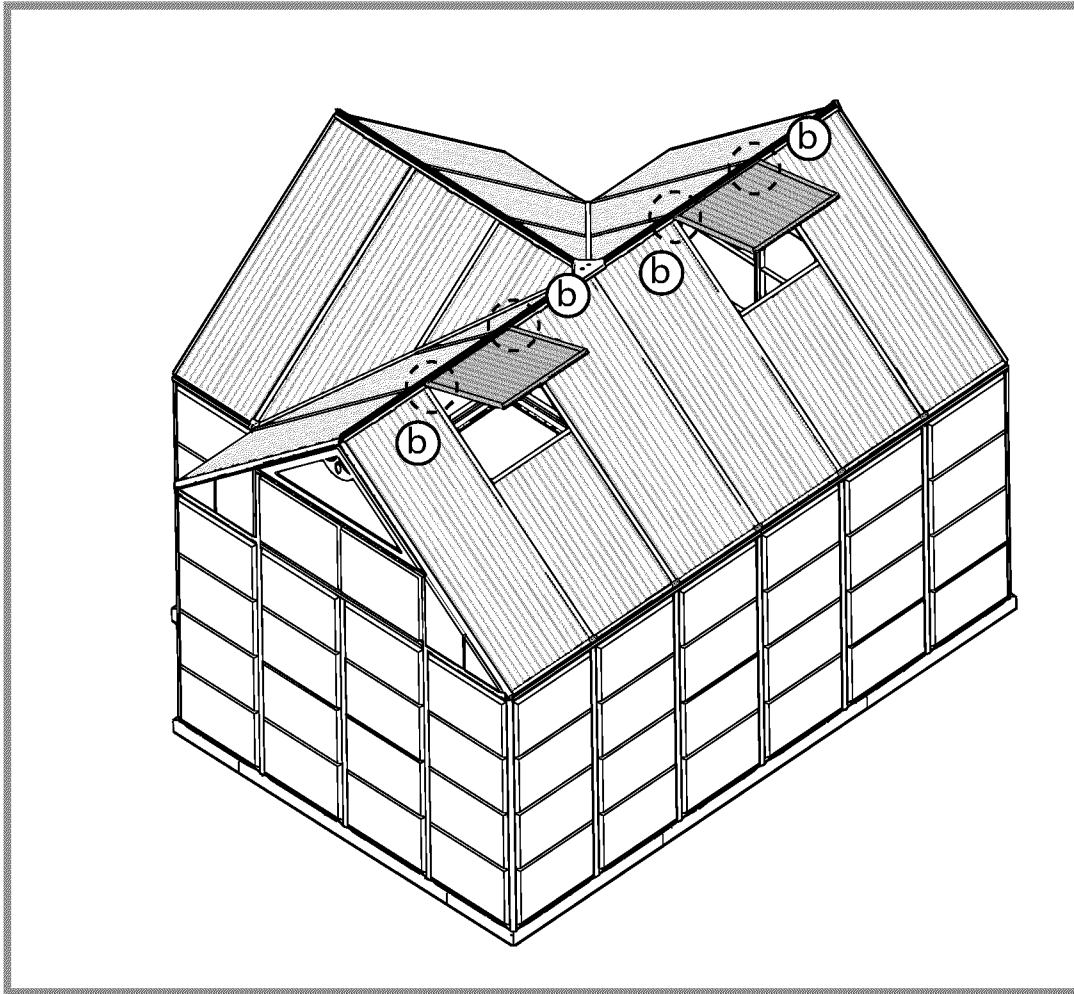
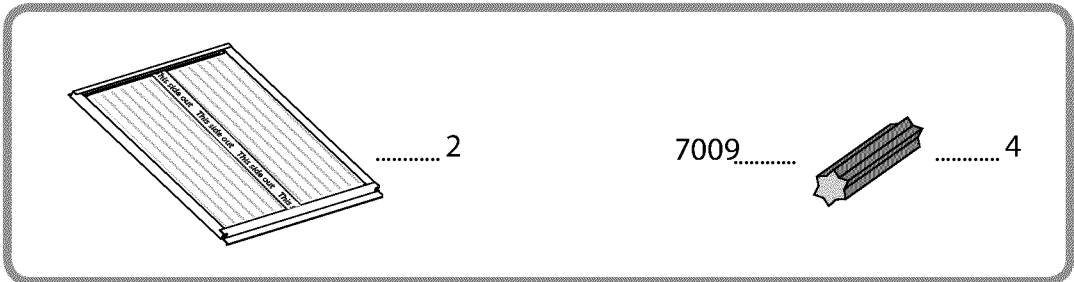
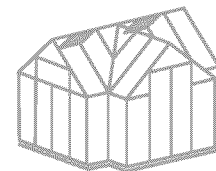

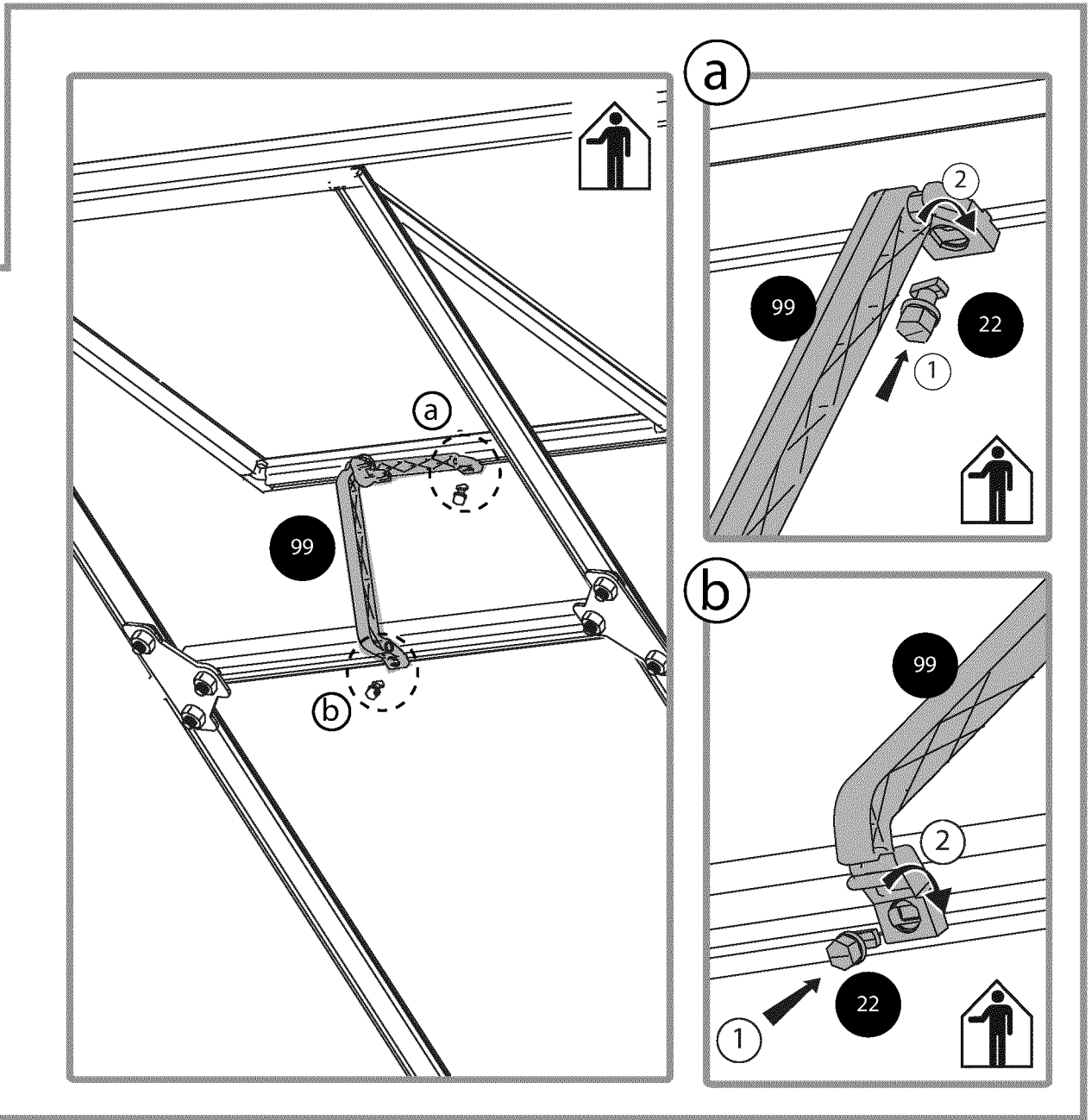
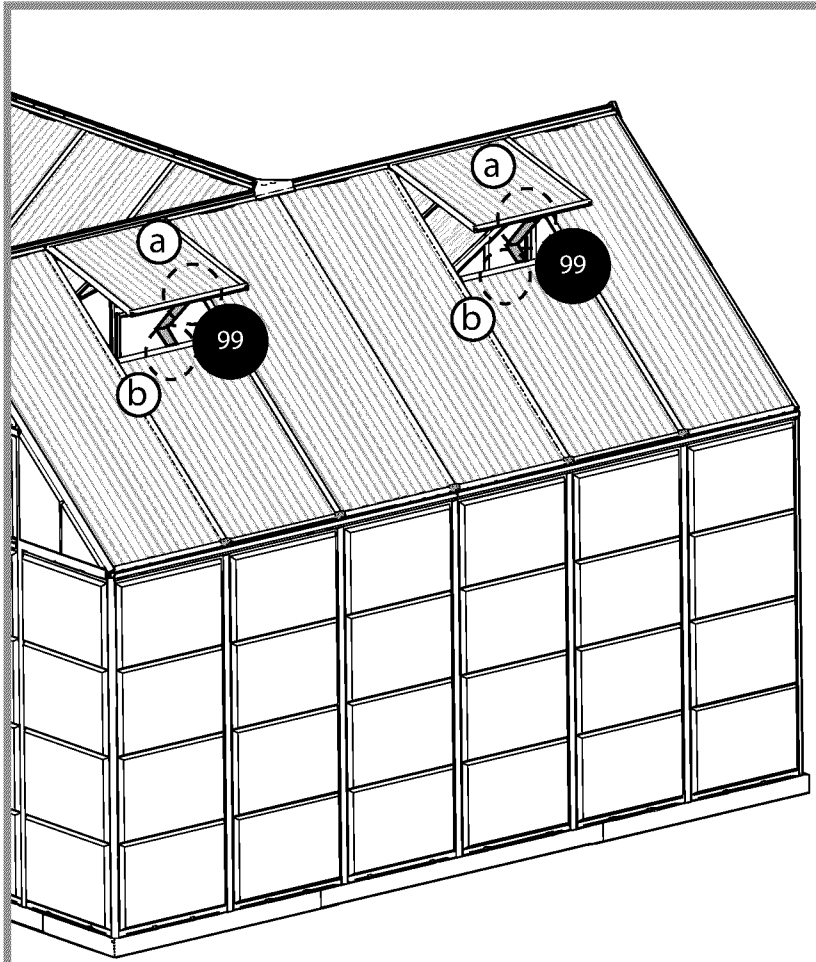
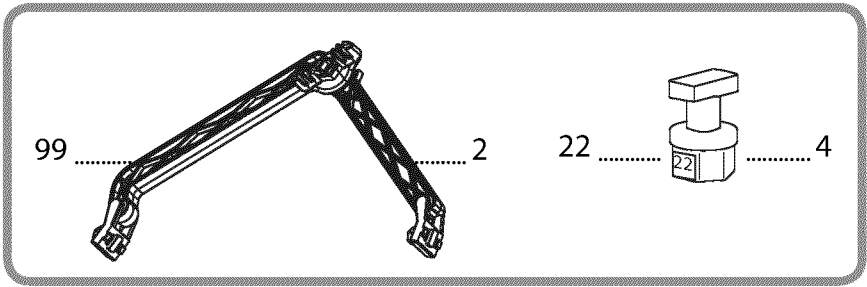
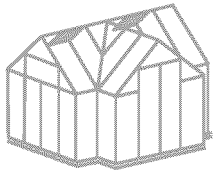

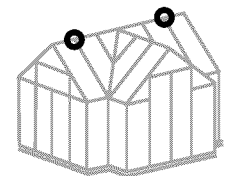

7330 2 411 2 7284 2 412 4

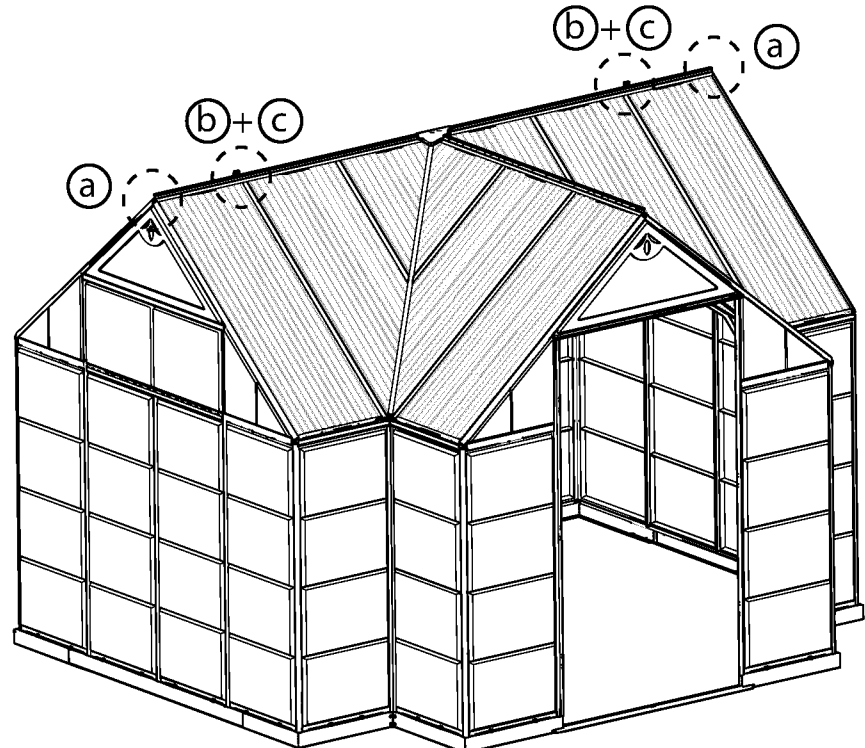
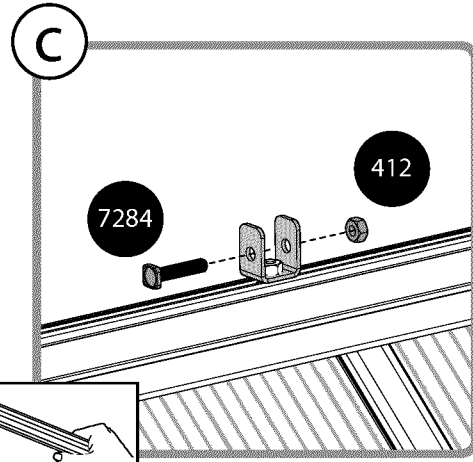
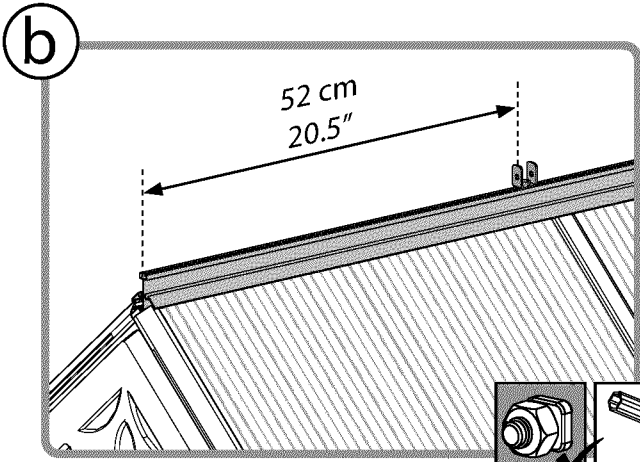
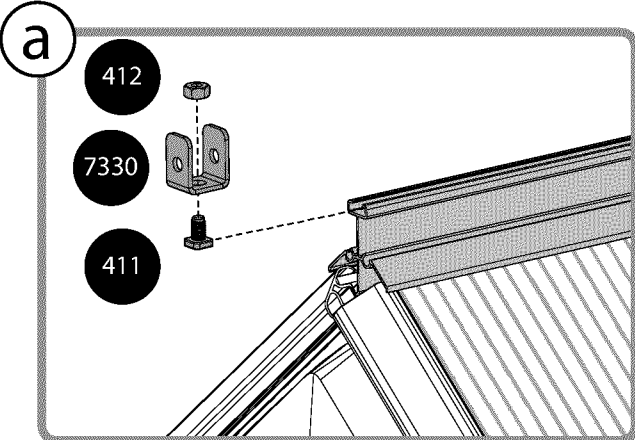

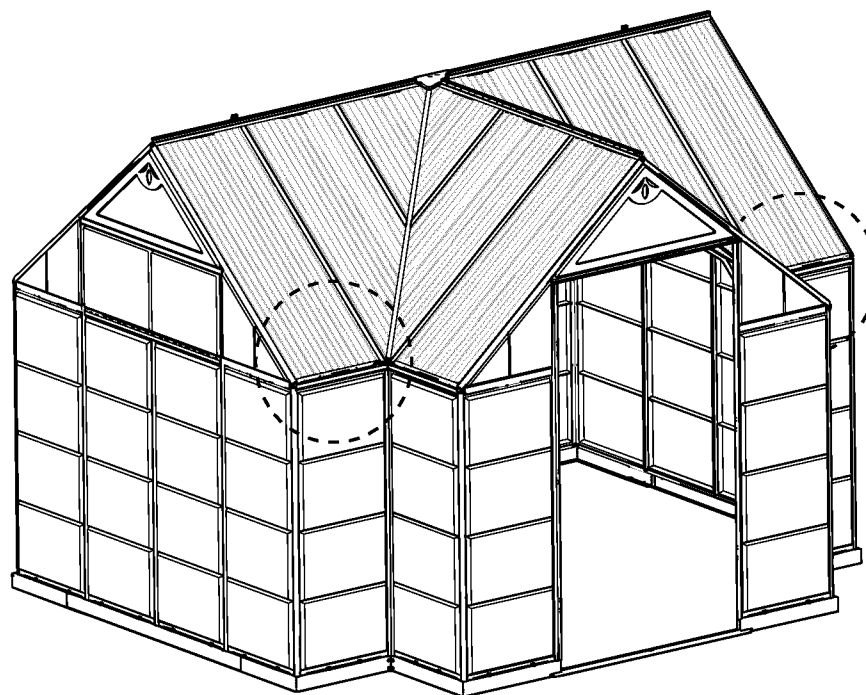
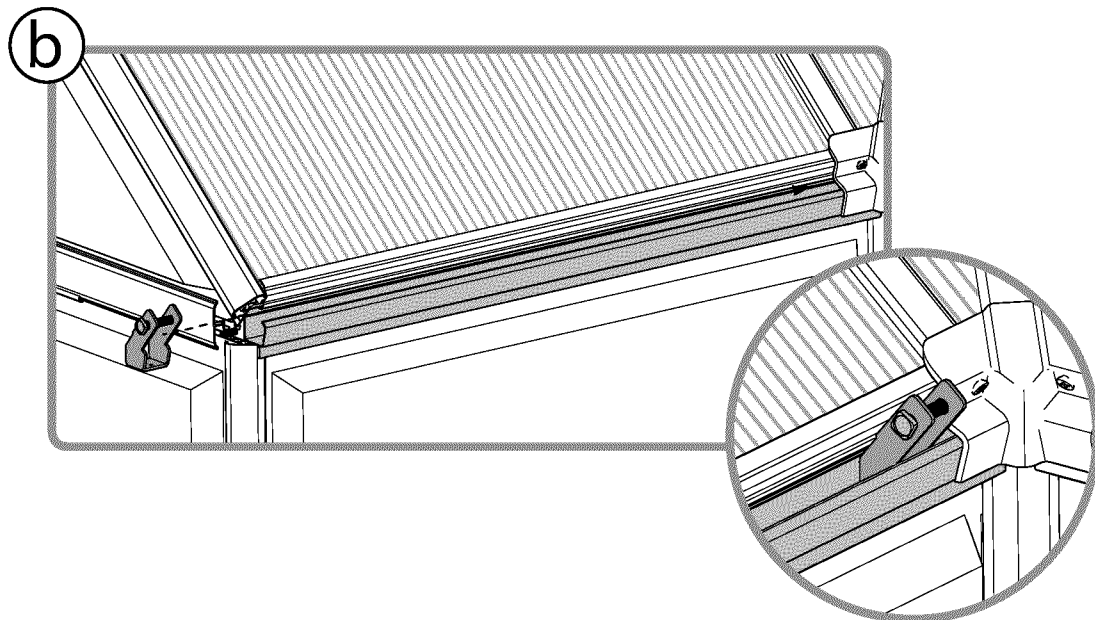
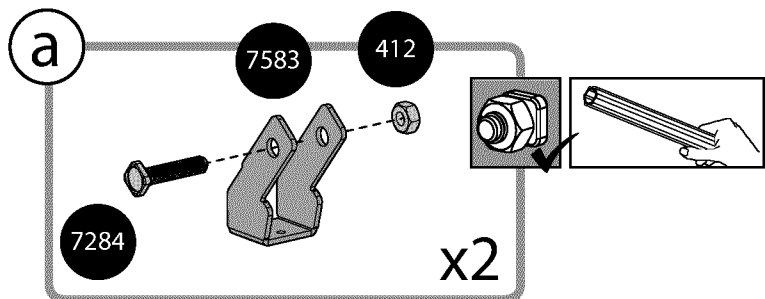
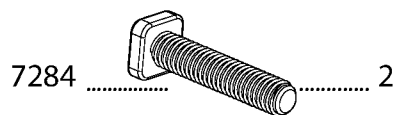
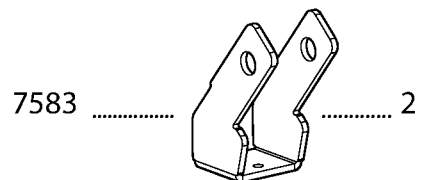
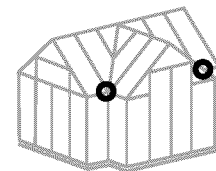

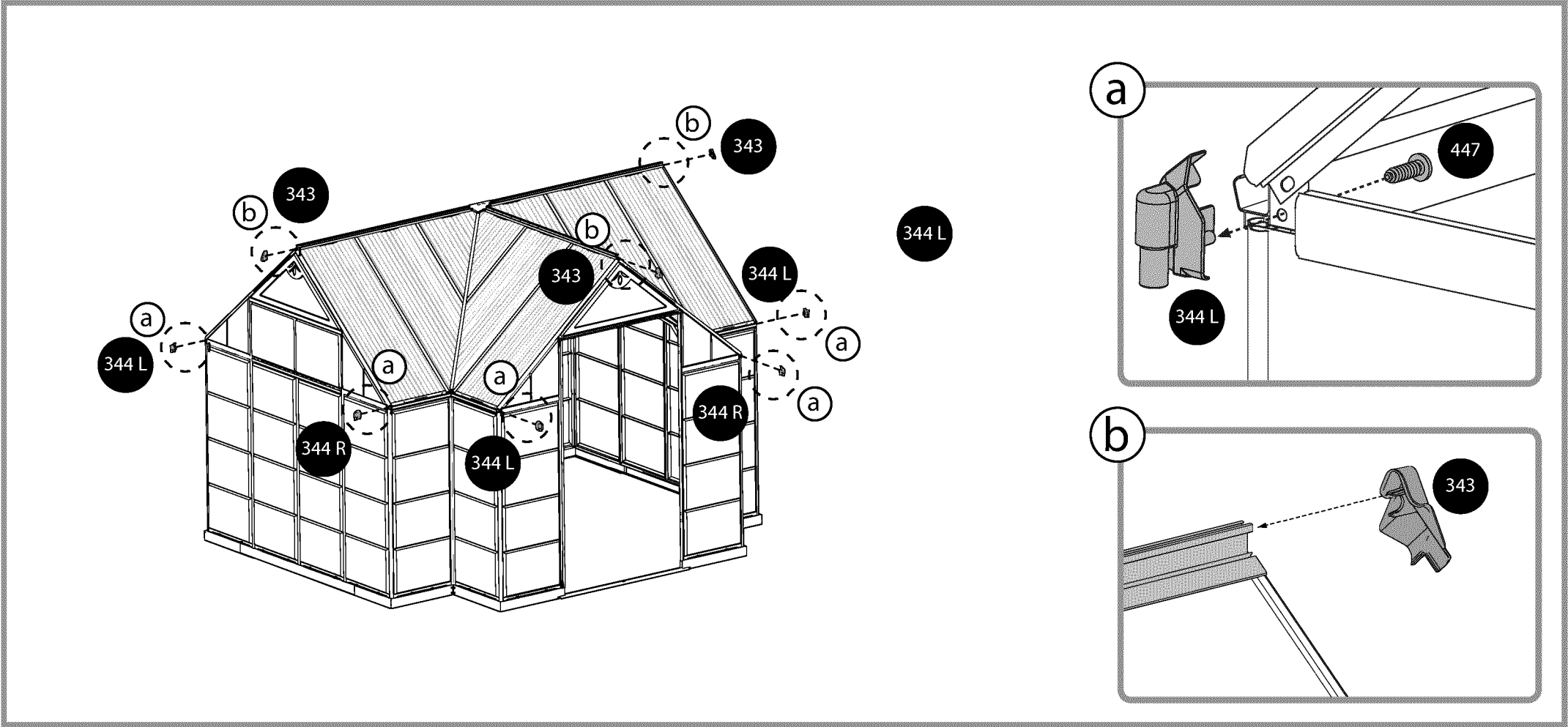
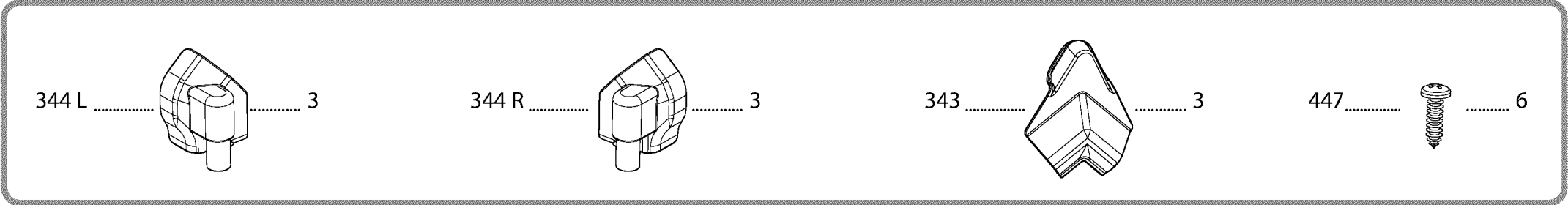
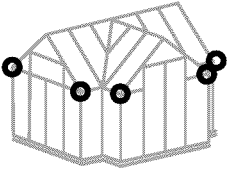

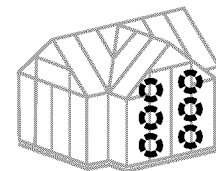

464 12

465 24

422 24

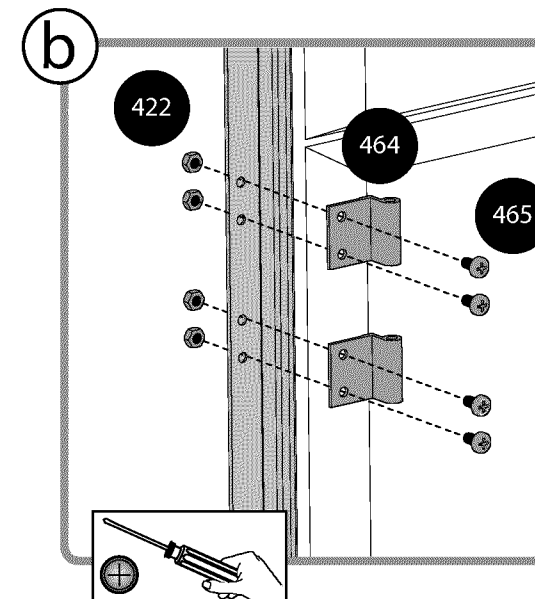
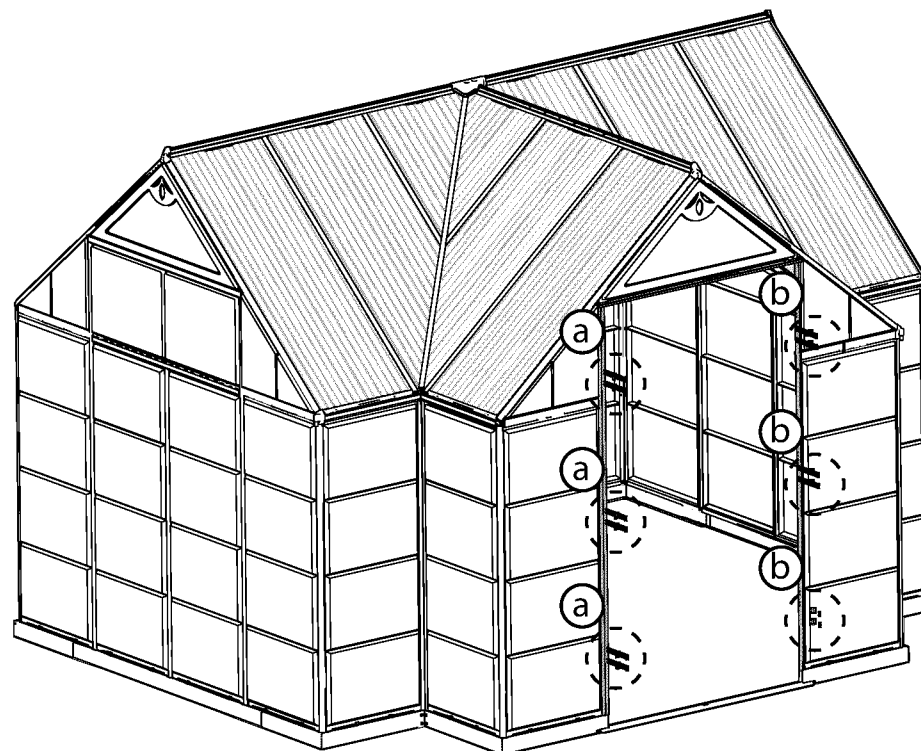
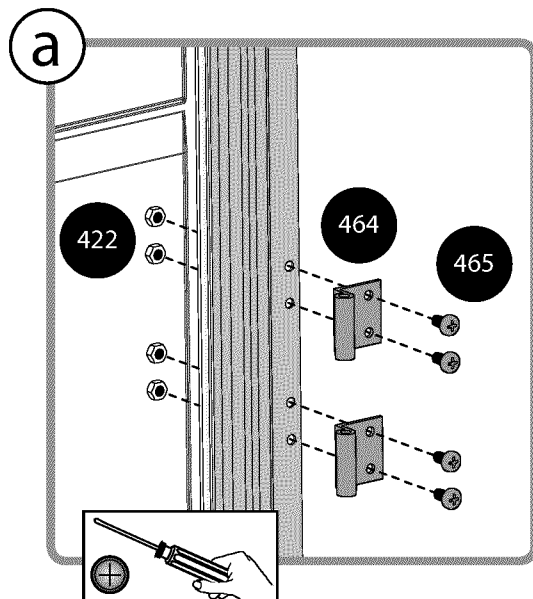

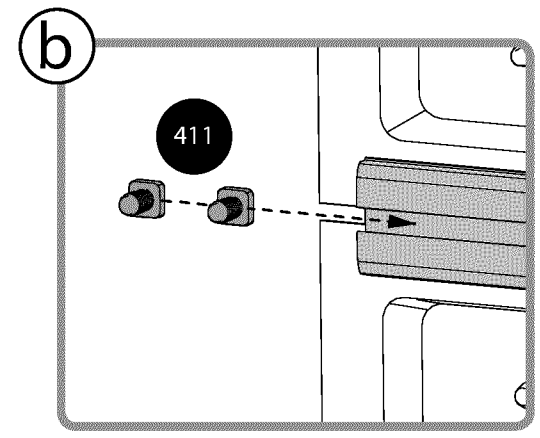
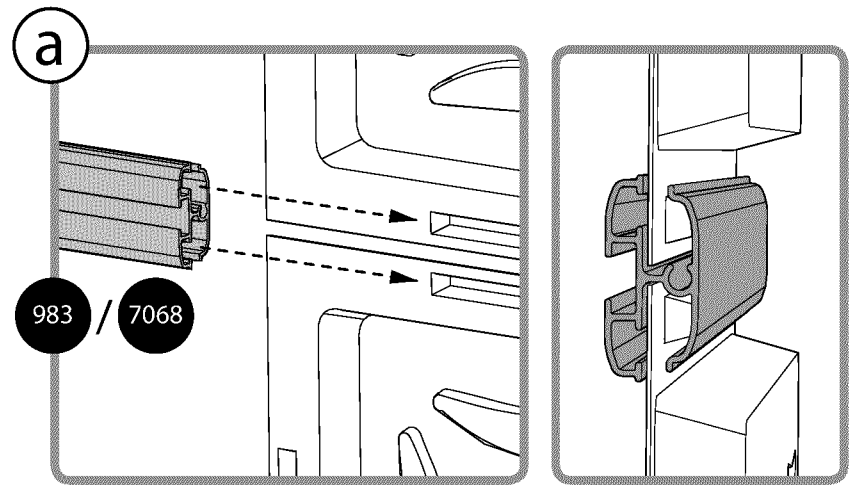
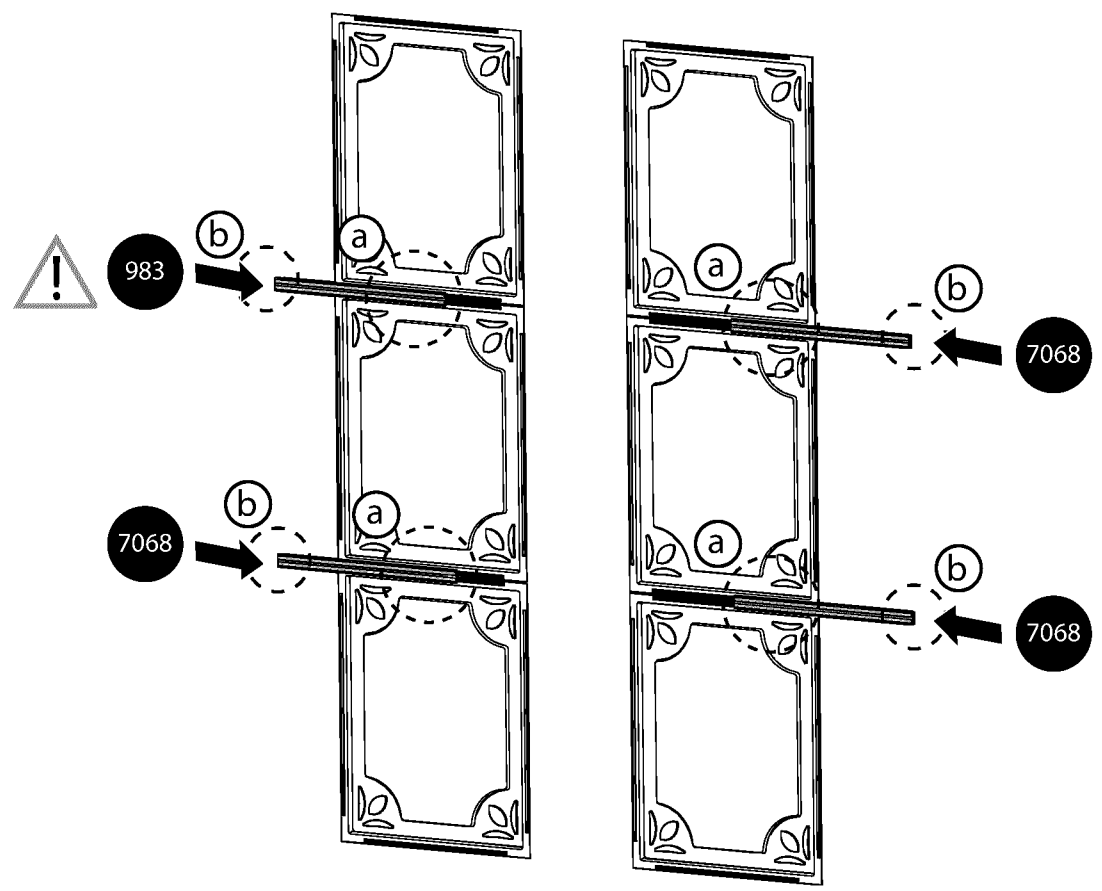
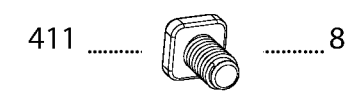
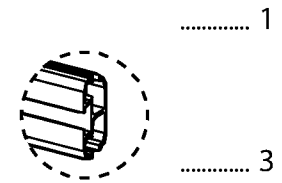
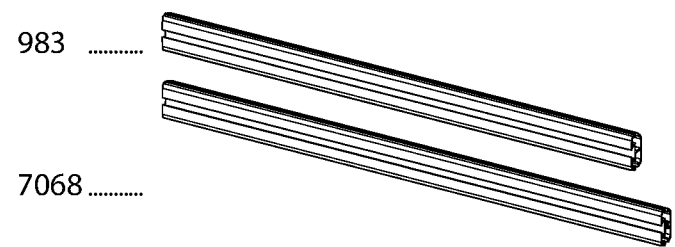
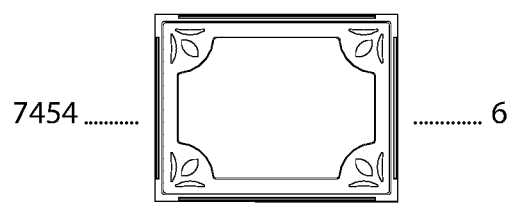
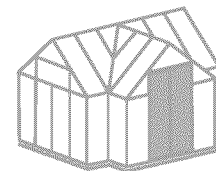

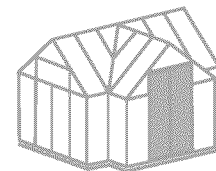

7497 4

984 2

7066 2

4008 4



a

b

c

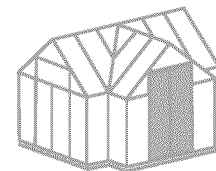
d



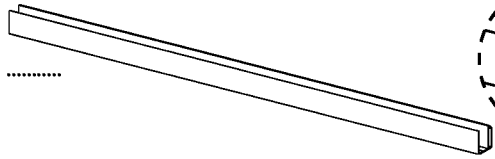
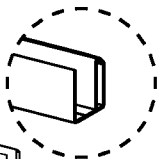

7271   1

984   2

411  31

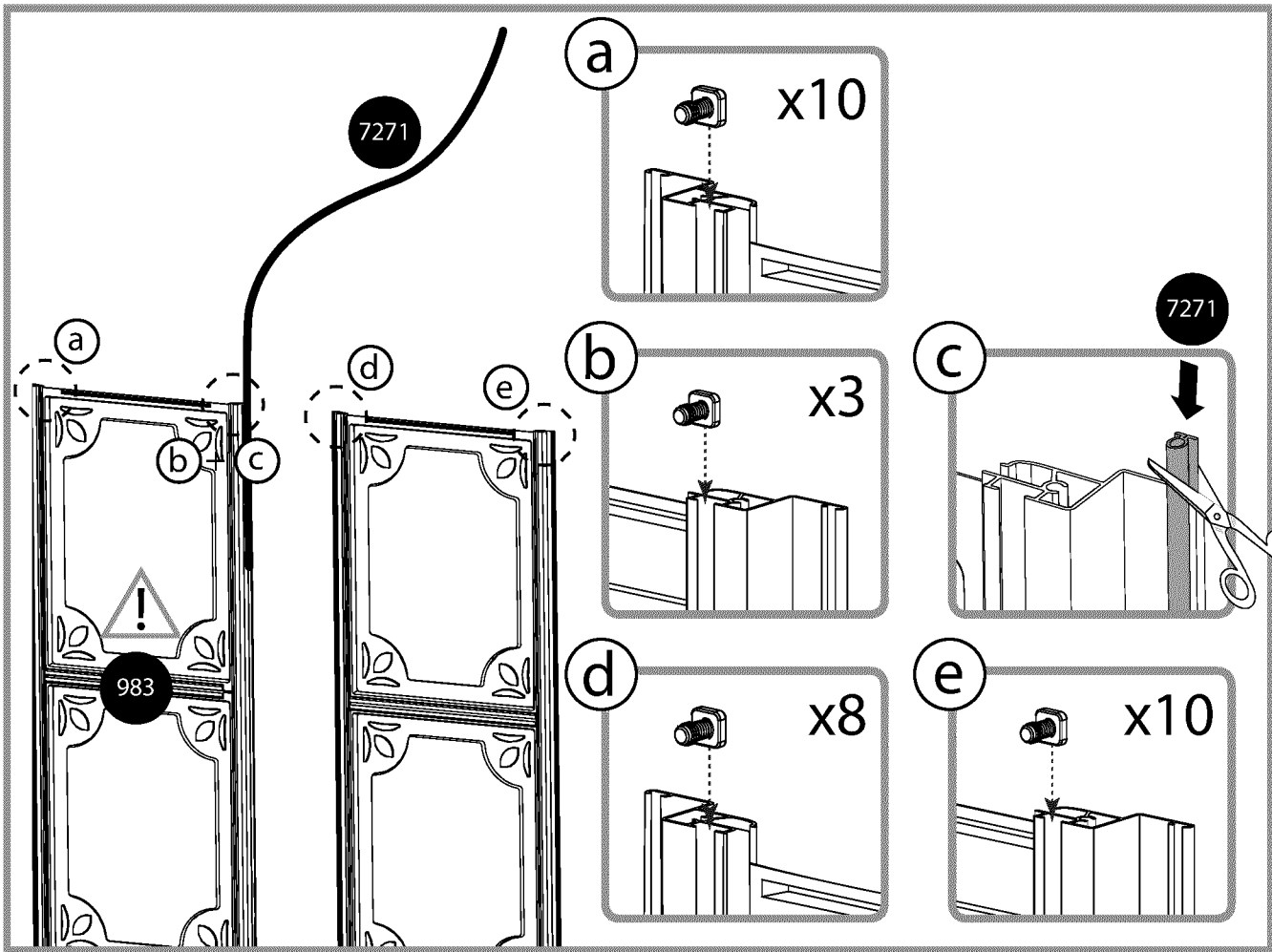
4008  4



a  x10

b  x3

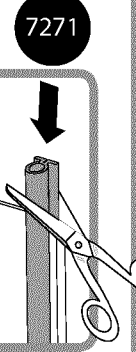
c 

d  x8

e  x10

983

7271

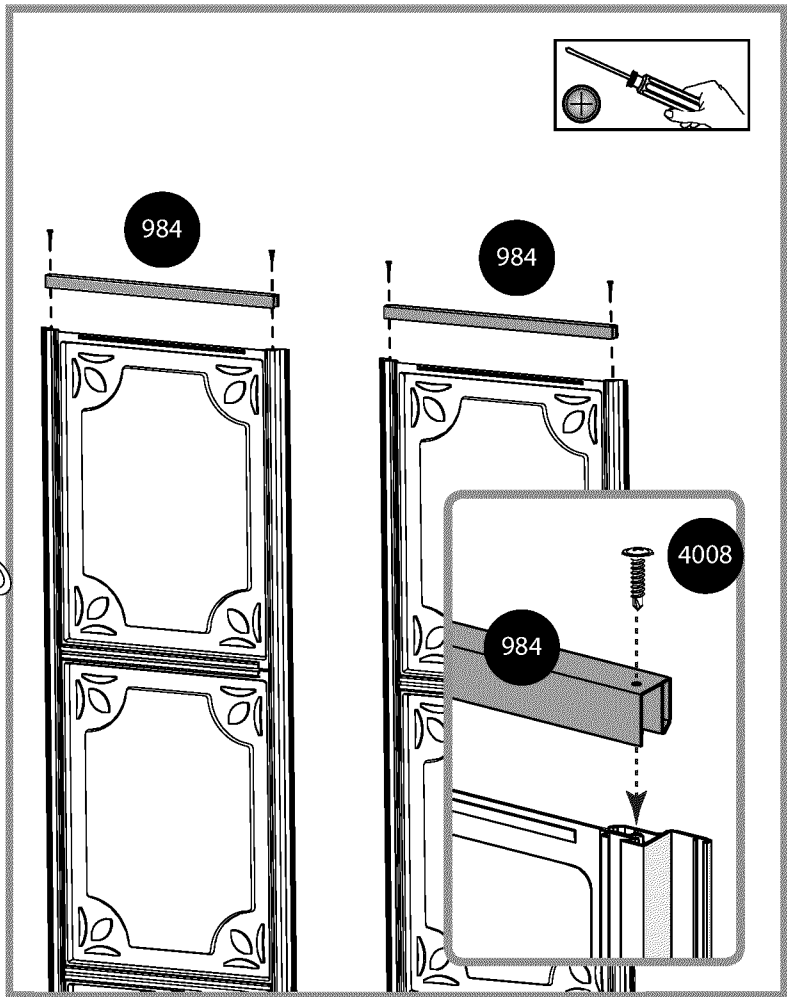

984

984

984

4008

984

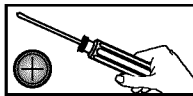

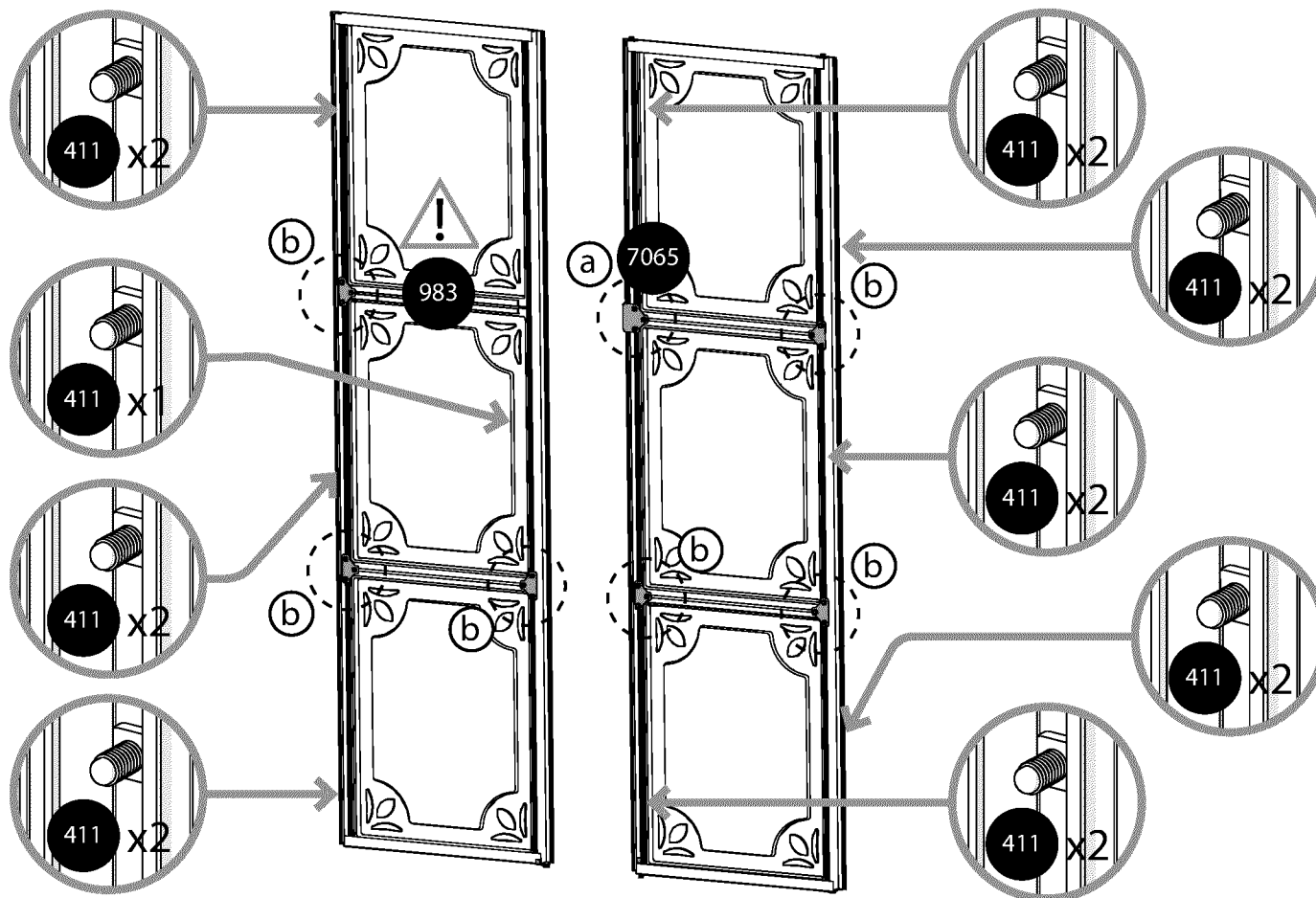
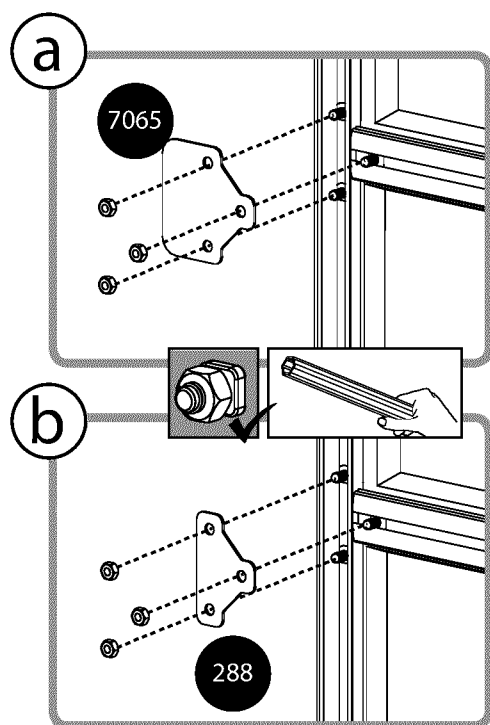
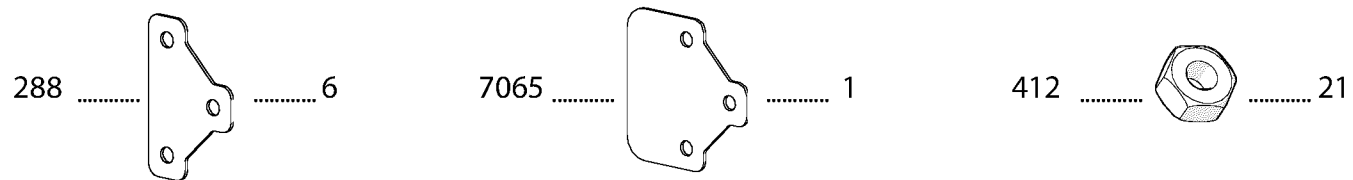
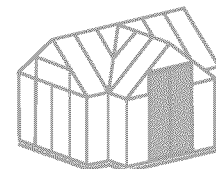

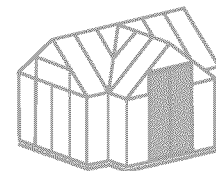

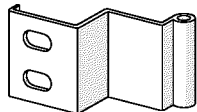
462  6

412  12

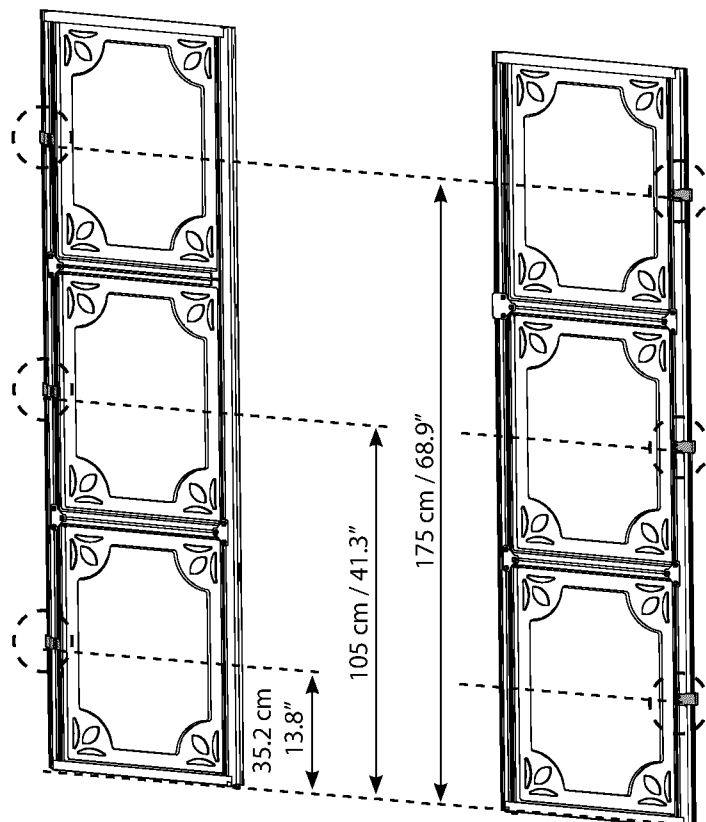
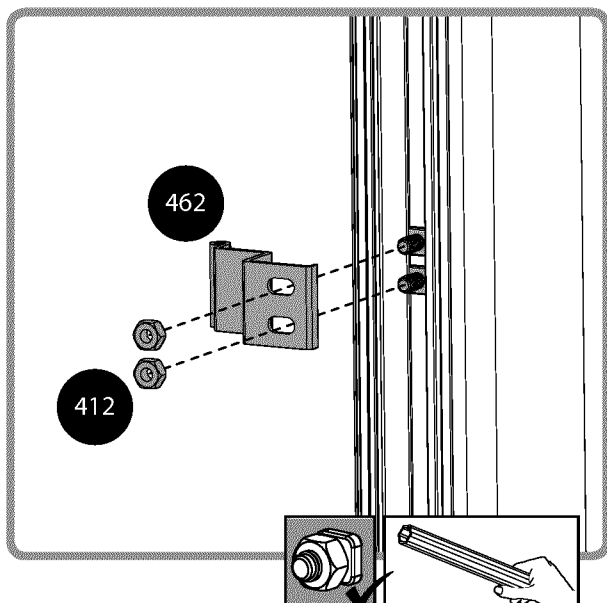

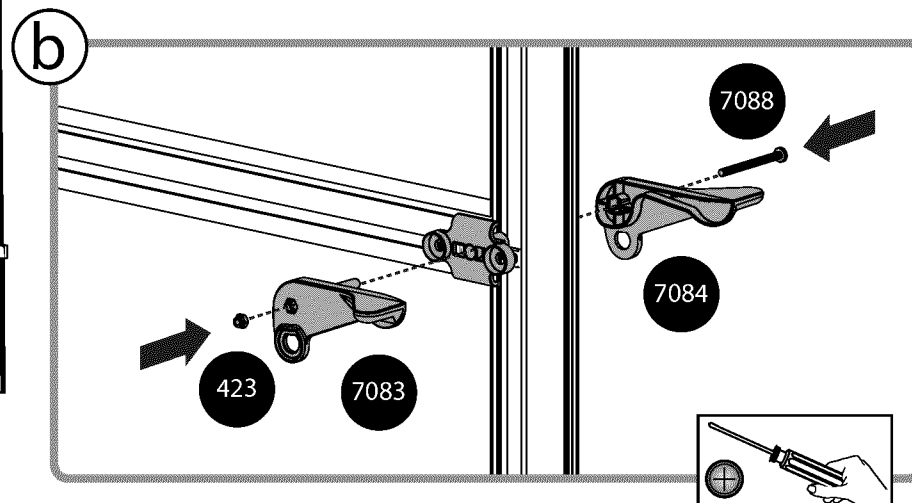
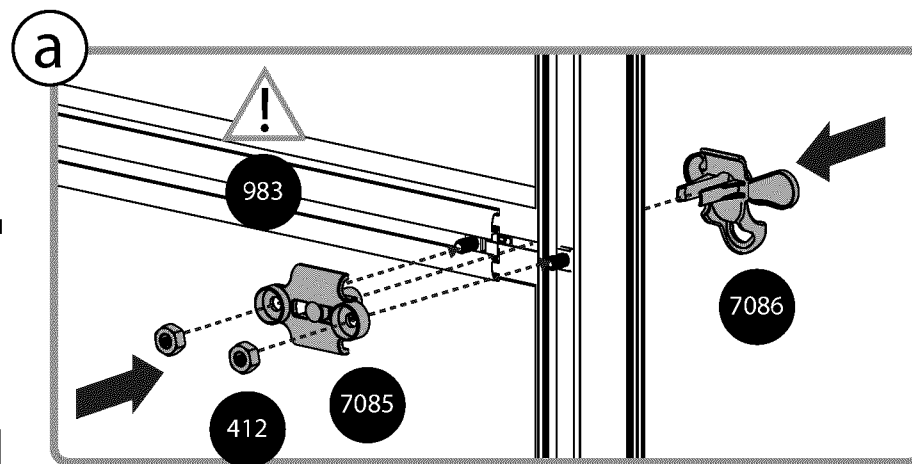
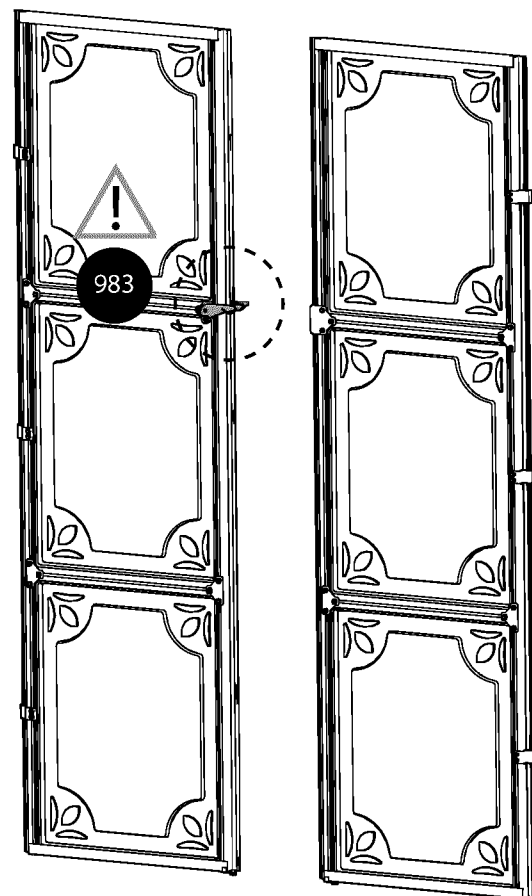
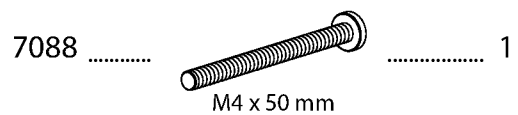
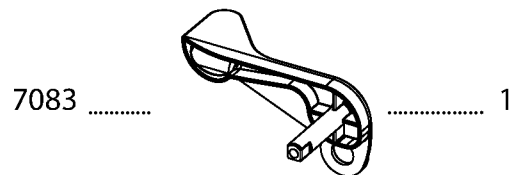
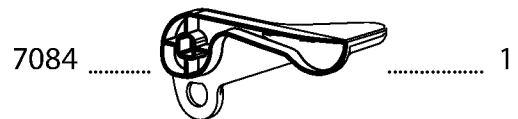
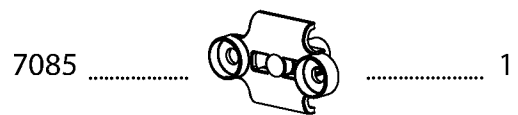
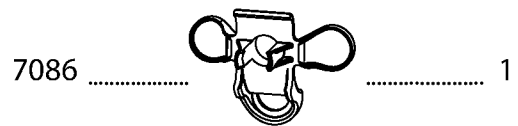
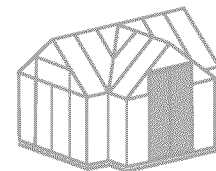

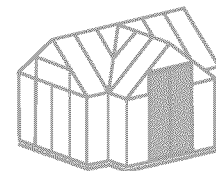

7082 2



7067 2

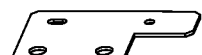

412 4

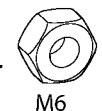

421 4

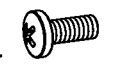

M4 x 16mm

422 4



M4

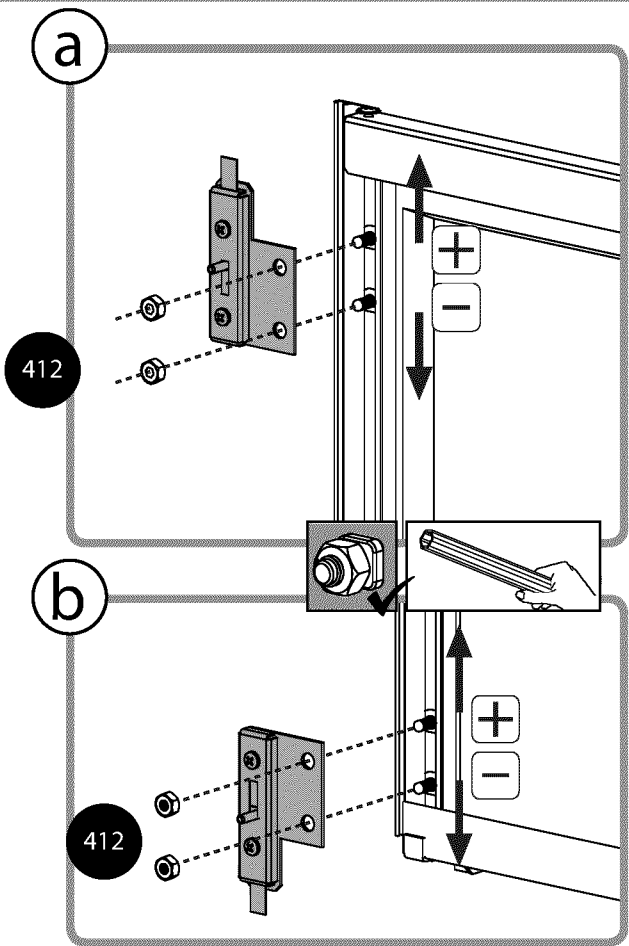
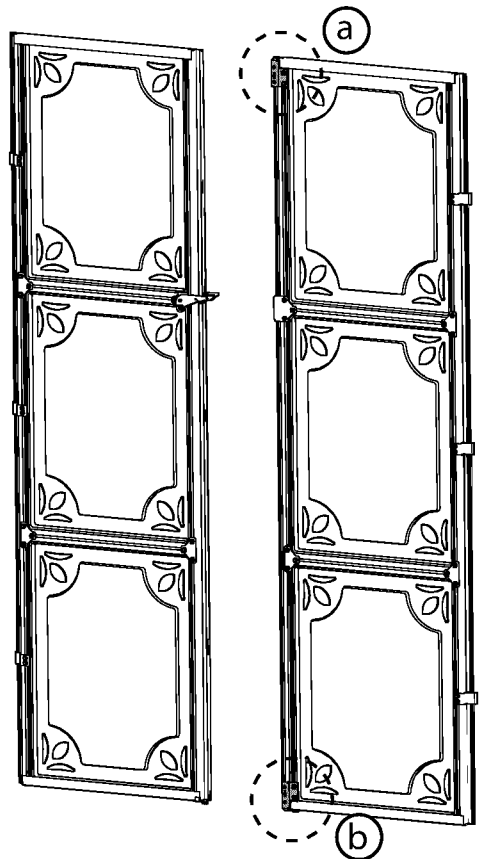
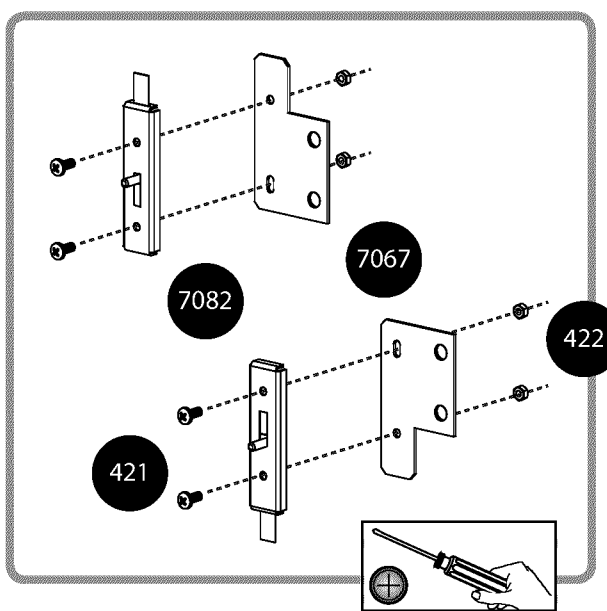

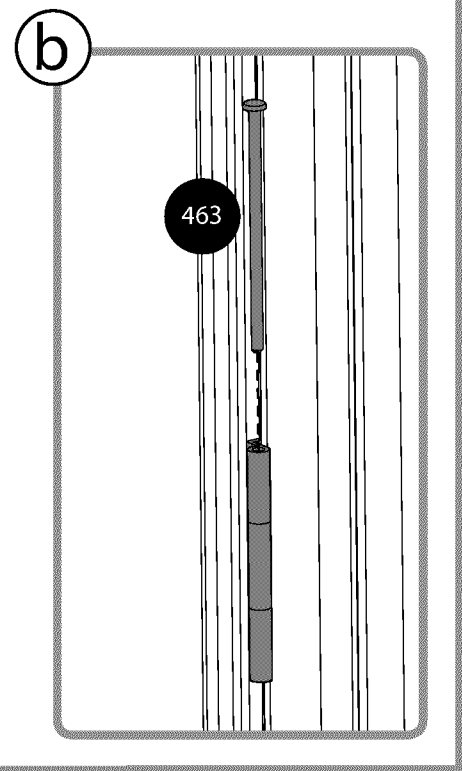
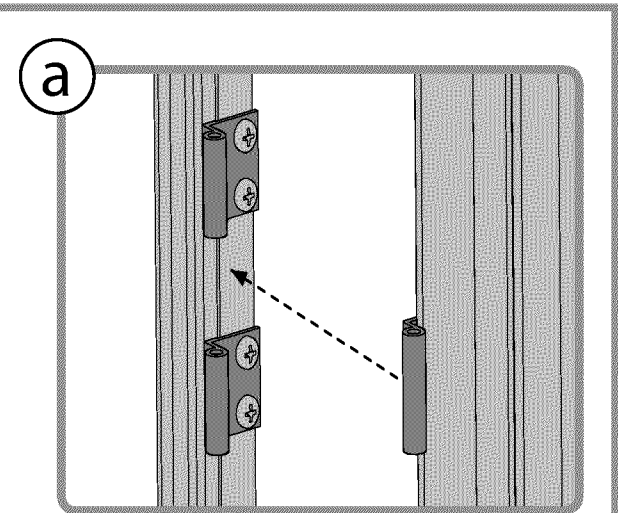
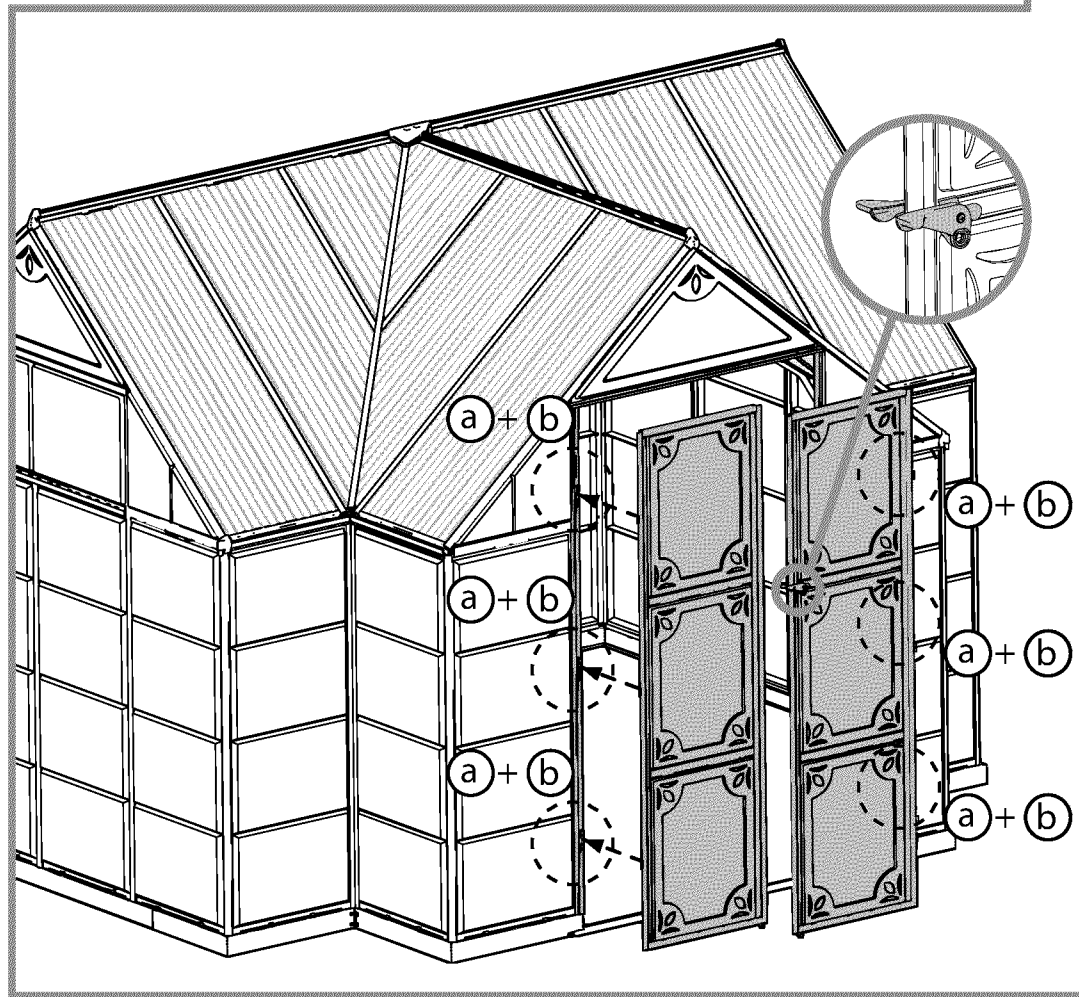
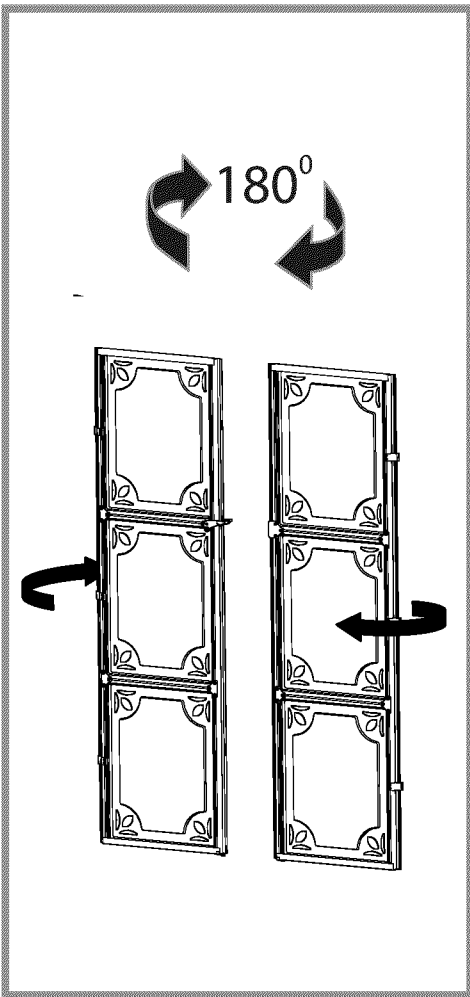
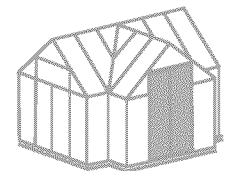

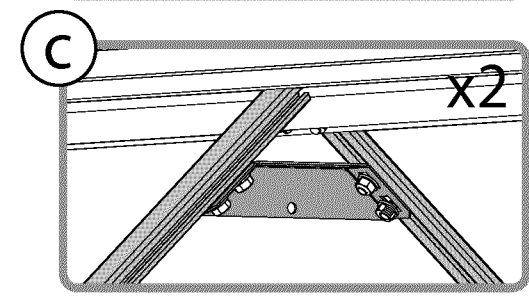
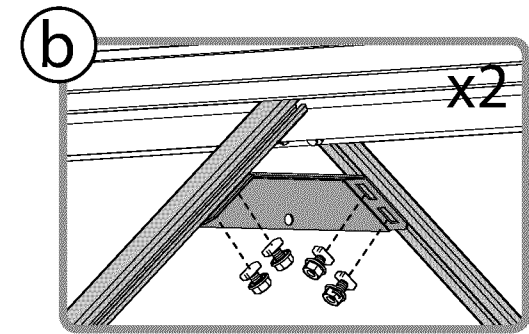
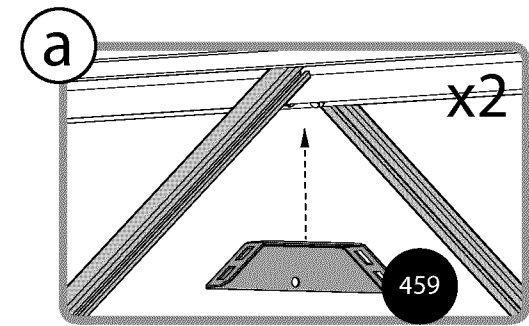
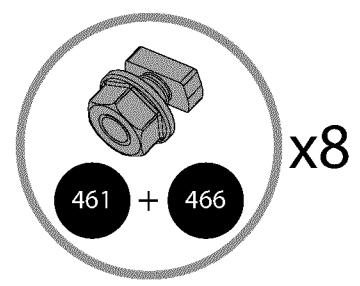
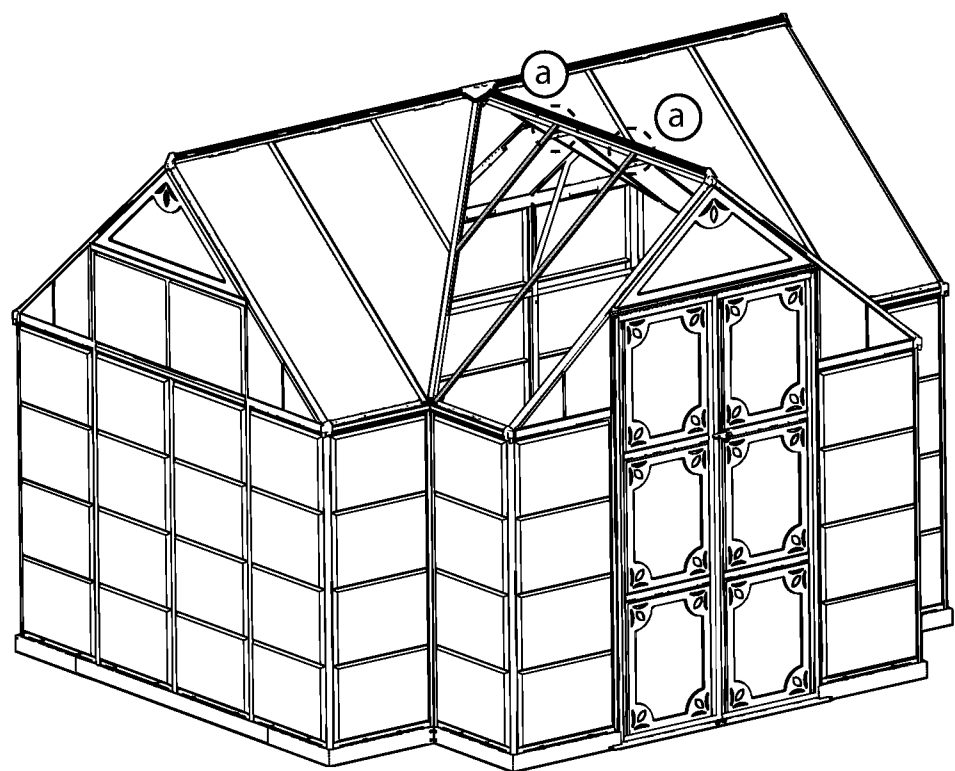
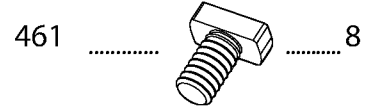
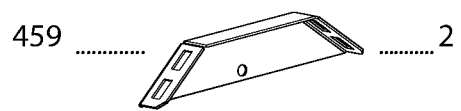
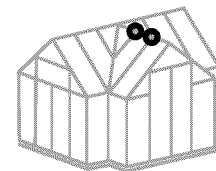

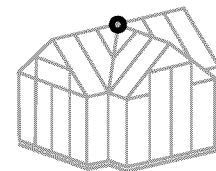

412 2
M6

7531 1

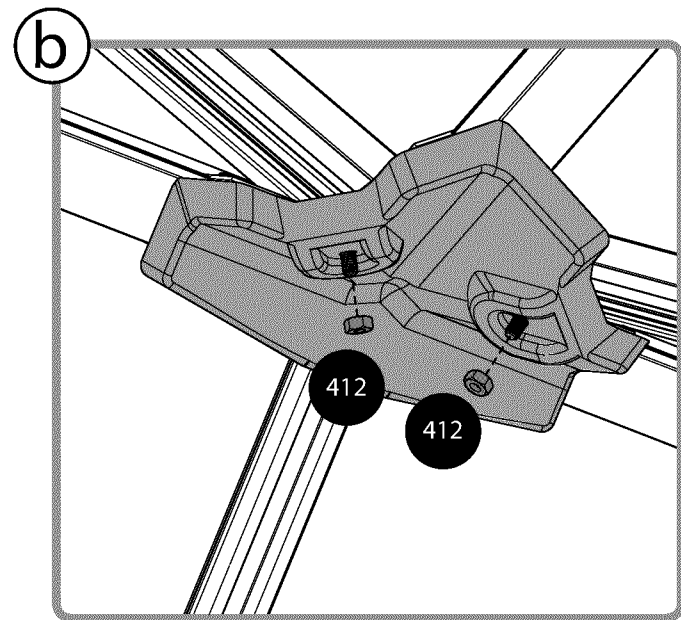
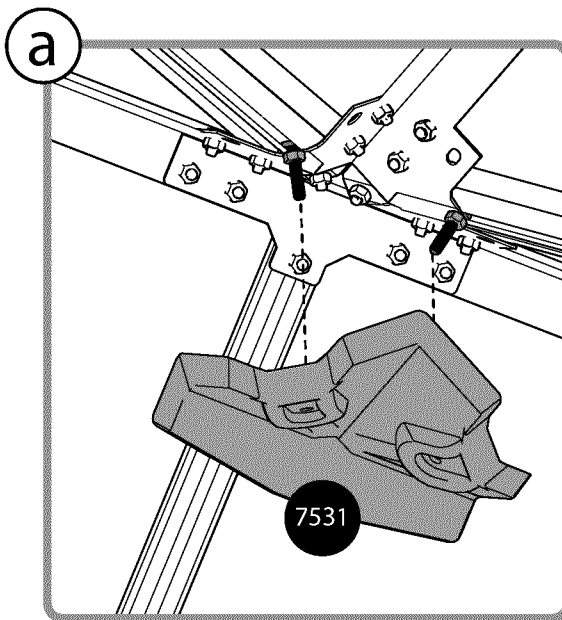
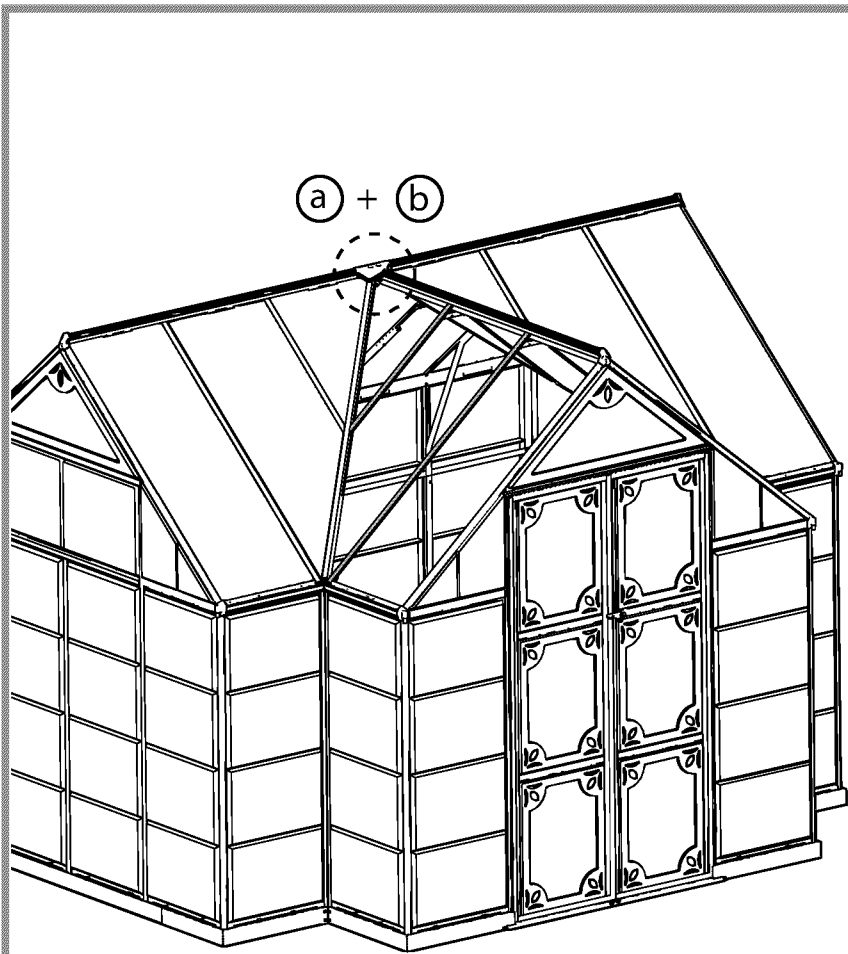

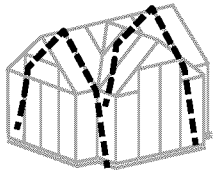

7327 2

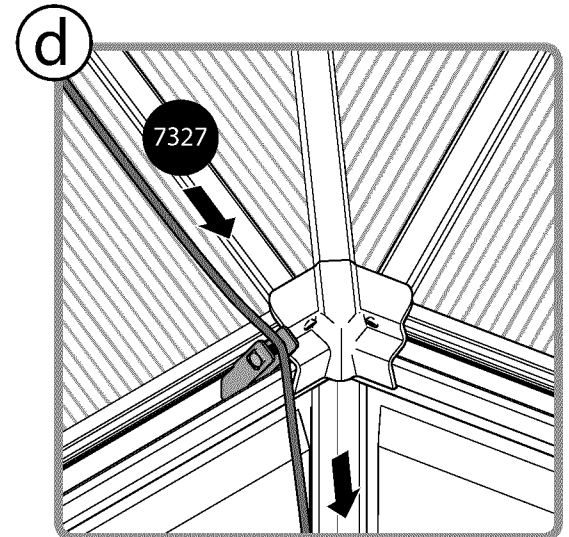
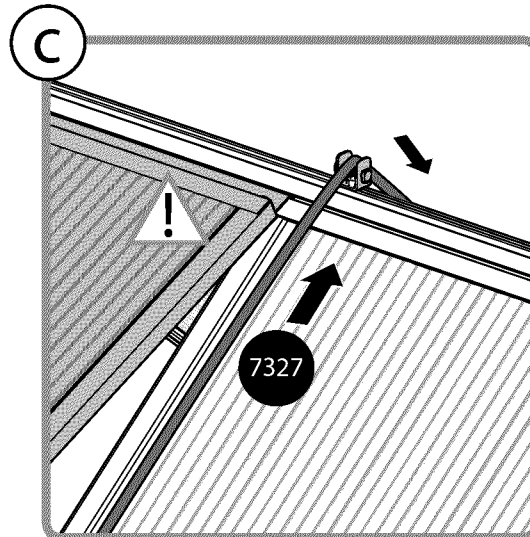
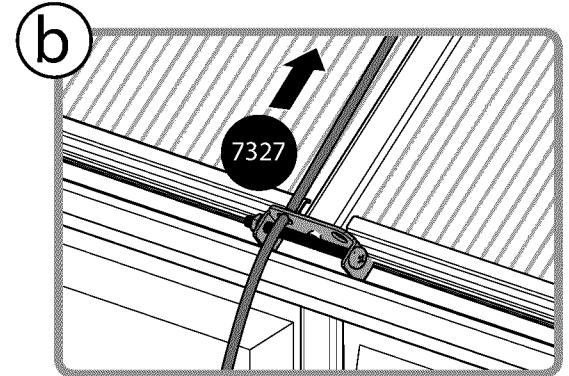
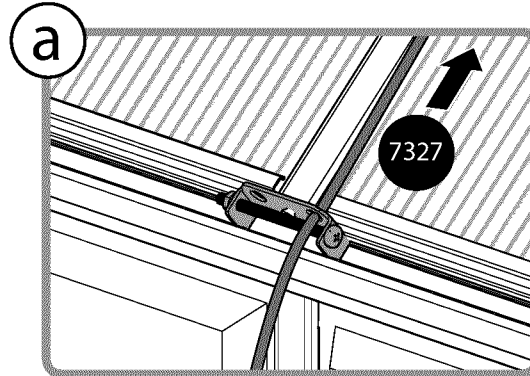
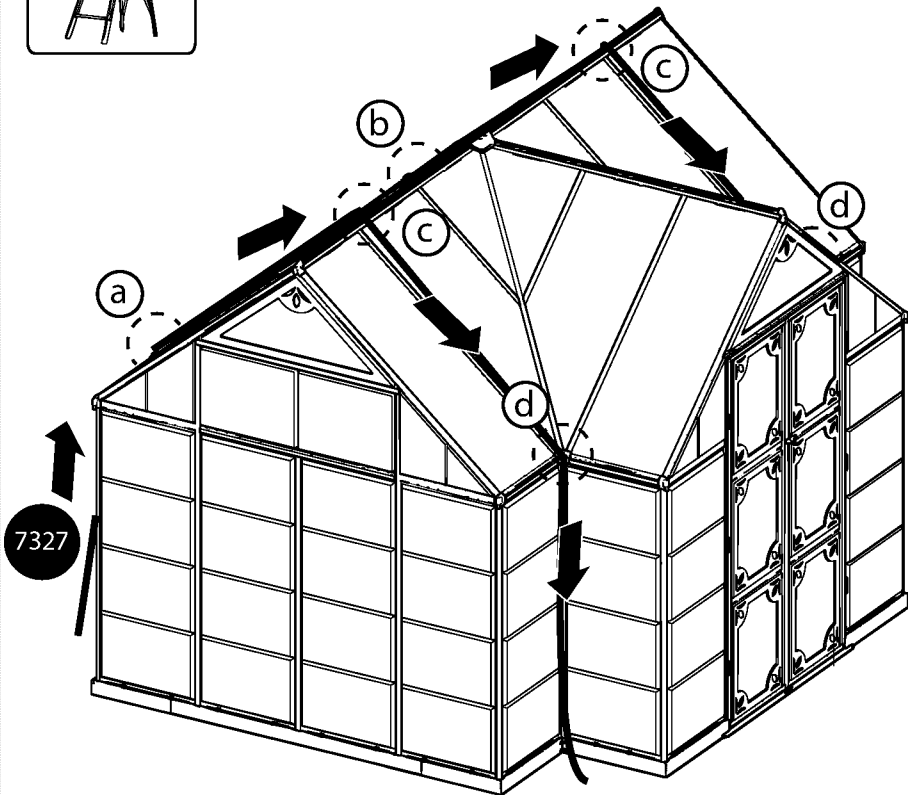
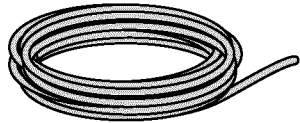

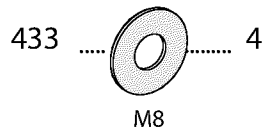
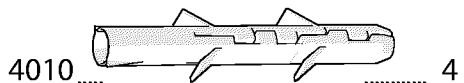
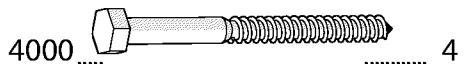
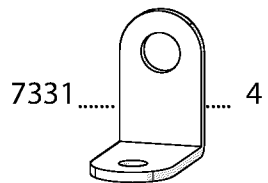
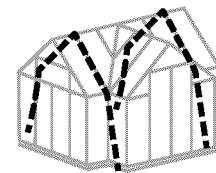

OR

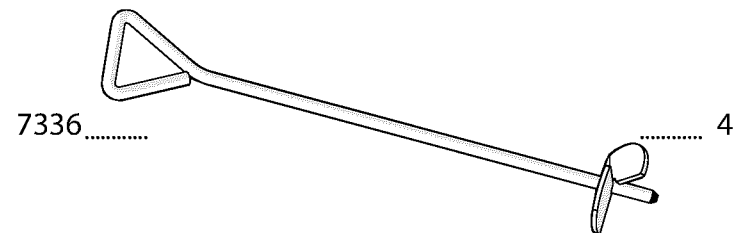

1

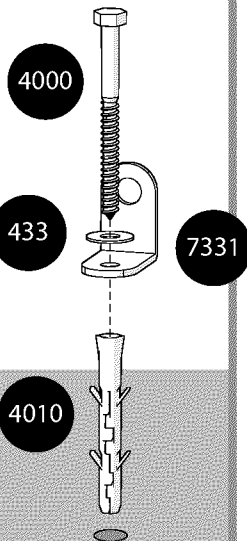
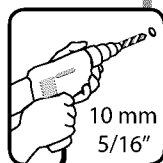

OR

2

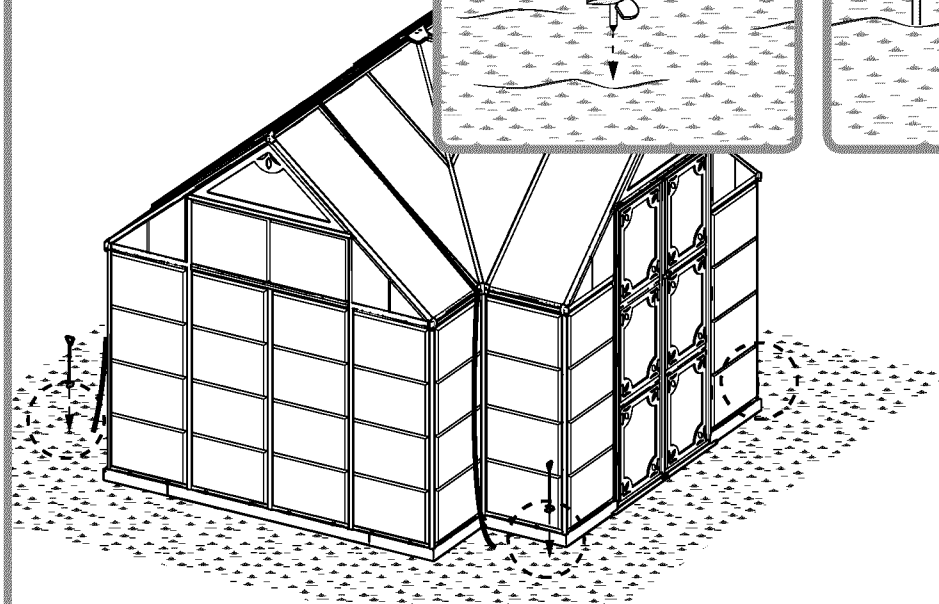
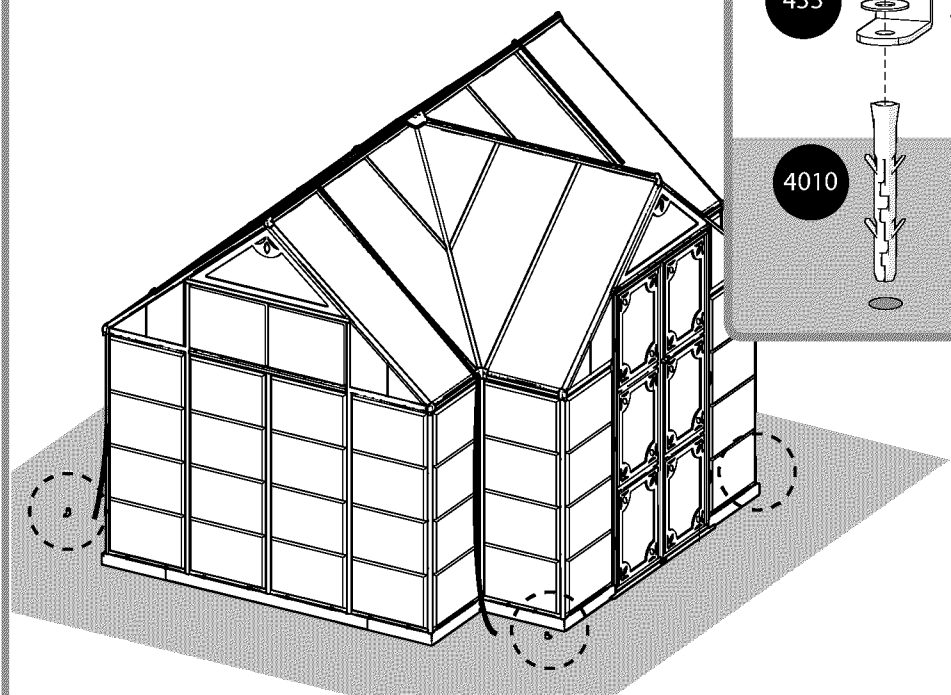
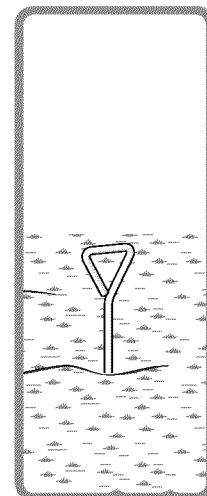
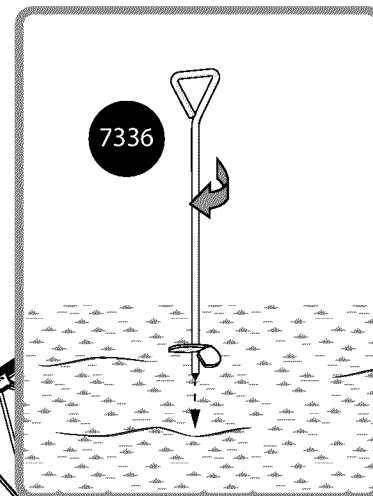

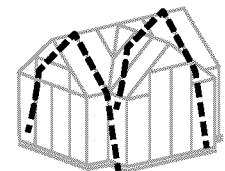

- 7333..... 2
- 7283..... 2
M8
- 414 2
M8
- 433 2
M8

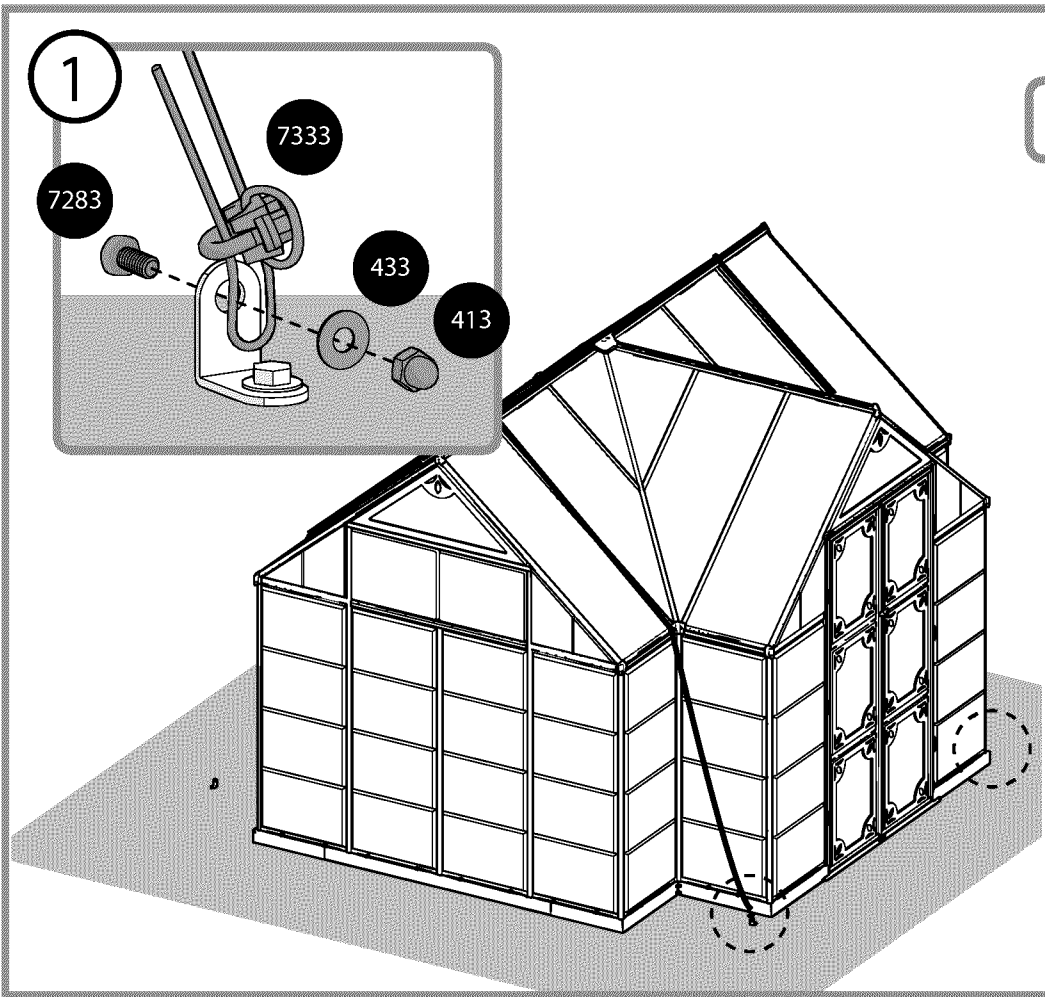

OR

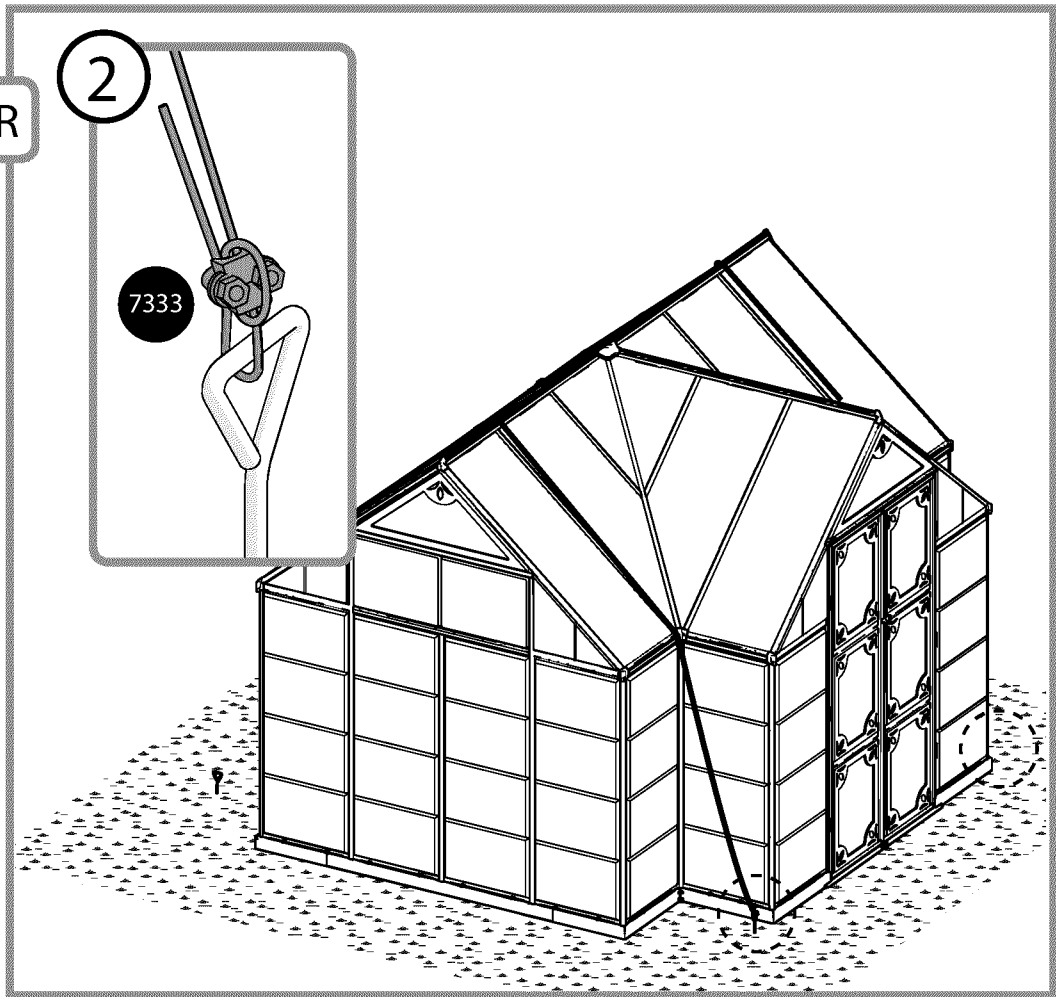

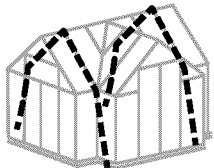

7333..... 2

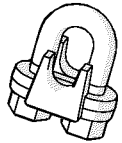

7332..... 2

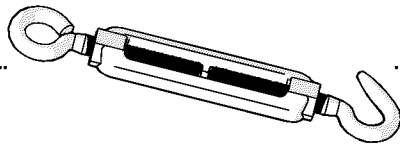

1

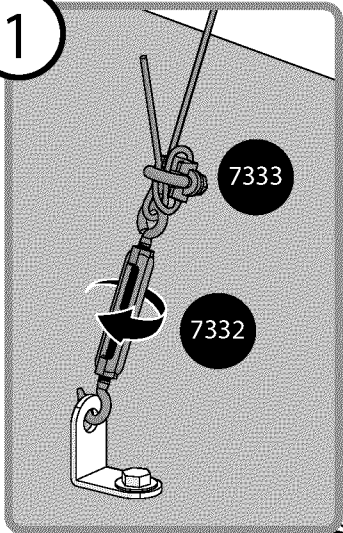

7333

7332

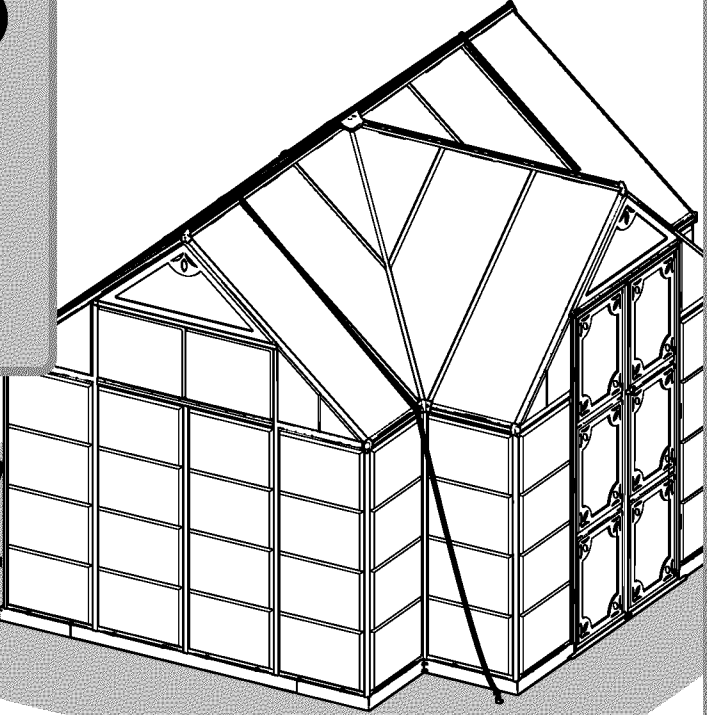

OR

2

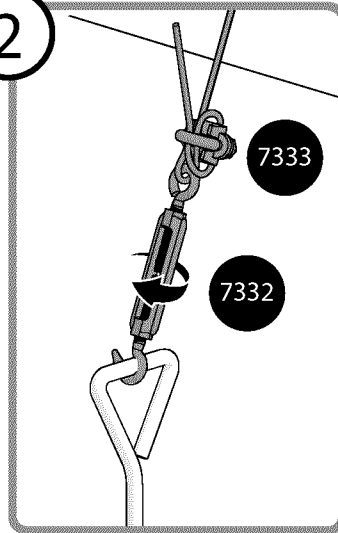

7333

7332

