

Operation Manual

LIFAN Gasoline engines



Read and follow the operating instructions and safety information before using for the first time.

Technical changes reserved!

Due to further developments, illustrations, functioning steps and technical data can differ insignificantly.

Updating the documentation

If you have suggestions for improvement or have found any irregularities please contact us.



The information contained in this document is subject to change without prior notice. No part of this document can be copied or duplicated in another form without the prior written consent of WilTec Wildanger Technik GmbH. The WilTec Wildanger Technik GmbH assumes no liability for any errors in this user manual or the connection diagram.

Although WilTec Wildanger Technik GmbH has made every effort to make sure that this user manual is complete, accurate and updated, errors cannot always be avoided. In the event of problems with this user manual please complete and send this form back to us.

FAX-notification (+++49 2403 55592-15),

from: _____

Name: _____

Firm: _____

Tel/Fax: _____

I would like to report the following mistakes:

Customer Service WilTec Wildanger Technik GmbH

e-mail: service@WilTec.info

Tel:++ +49 2403 55592-0

Introduction

Thank you for purchasing this quality product. **To minimize the risk of injury we urge that our clients take some basic safety precautions when using this device. Please read the operation instructions carefully and make sure you have understood its content.**

The electric part of the device contains no parts that can be inspected or serviced by the user. Leave the maintenance, adjustment and repair to qualified technical personnel. In case of unauthorised intervention the 2-year warranty is no longer valid! Keep these operation instructions safe.

This petrol engine offers

- One-cylinder, 4-stroke engine♣
- Hand or electric starter♣
- Powerful air cooling system♣
- OHV - Over Head Valve♣ (except 152F)
- TCI Ignition Module♣
- Fan hood from special silent steel plate♣

Our series of air-cooled four-stroke gasoline engines has been developed in terms of material and energy saving. Due to their compact design, the devices are easy to carry to every location and convenient to handle. They offer a wide range of applications in the fields of craft, industry, horticulture and agriculture, or household.

This manual will help you use your engine optimally. Please read it carefully **before** using the device in operation. By doing so the life of the device is significantly increased.

Please contact us if you have any questions or comments about these instructions. In some cases, the equipment of the apparatus may vary from the kind described in this guide.

Safety instructions:



Please follow the following tips and ideas for your own safety, otherwise damage to the equipment or injury of the operator may occur.

- Make sure that the engine operates only in well-ventilated environments, otherwise a health risk may occur because of the fumes.
- In the vicinity of other persons the engine has to work with due diligence. Make sure the exhaust pipe is free and accessible; it must not be covered or blocked.

- Before filling the tank with fuel, the engine must always be switched off.
- The tank must not be filled till overflowing.
- If the fuel is spilled on the device when filling, it has to be removed before starting the engine.
- Before changing the oil make sure that the cap of the tank is closed, so no oil can go into the petrol tank.
- Do not use the unit near open flames, flammable or explosive substances or gases, and flying sparks.
- The engine should be at least one meter away from house walls or other fixed facilities.
- Make sure that all moving and rotating parts are covered.





- While the device works, the individual components (eg exhaust) heat. Be careful when touching, because otherwise it may cause burns.
- Operate in a safe environment and keep children away from it while operating.
- Operate on a straight and solid surface. On slopes the device may leak fuel.
- A larger gap (oblique bar) can have, even with full oil level, negative influence on the gear.
- Take care when transporting the device; make sure there are no fuel leaks. We recommend that the tank is emptied and the fuel inlet valve closed.



Before commissioning the device keep the following points in mind:

- Make sure all fuel lines are connected and firmly attached, so no leakage may occur.
- Make sure all screws and nuts are firmly applied.
- Check the fuel and oil level and if necessary, fill fuel or oil

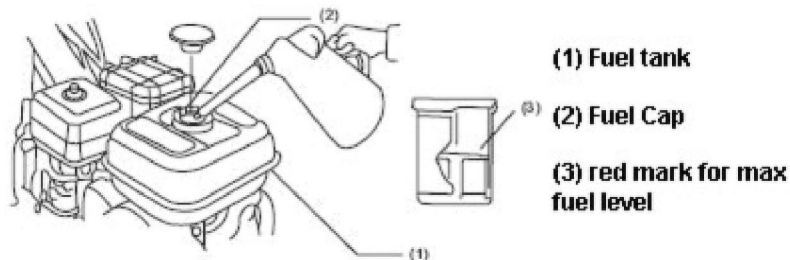
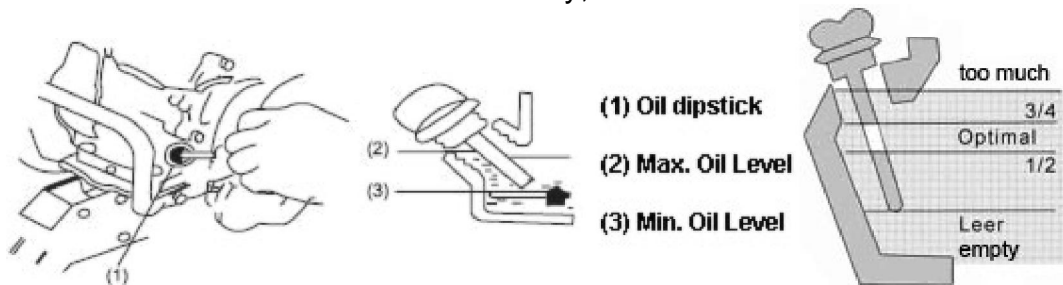

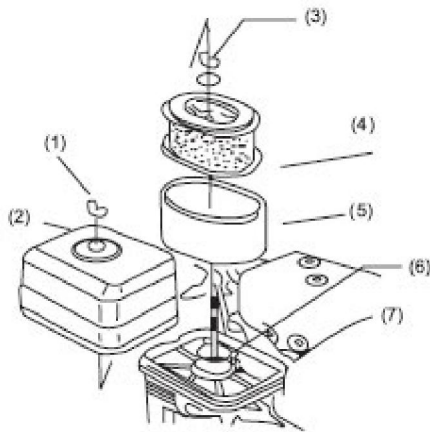

- (8) Wing nut
- (9) Air filter housing
- (10) Wing nut
- (11) Air filter
- (12) Foam filter
- (13) Seal
- (14) Air filter holder

The air filter should be regularly checked and if necessary, cleaned or replaced.

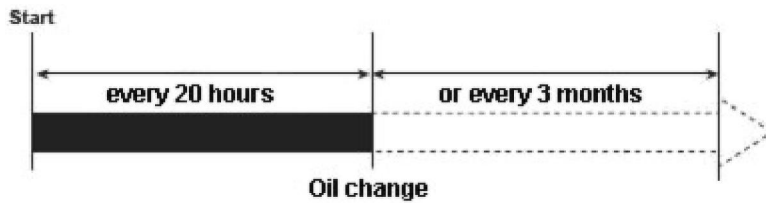

Crankshaft inclination		
tolerable inclination	$\leq 20^\circ$	
engine inclination		
tolerable inclination	$\leq 20^\circ$	

Start and stop the engine

Open the throttle (1) and the drain screw (3) of the carburettor. Once the fuel runs out, the drain screw (3) may be refastened. Then you can start the engine as usual.

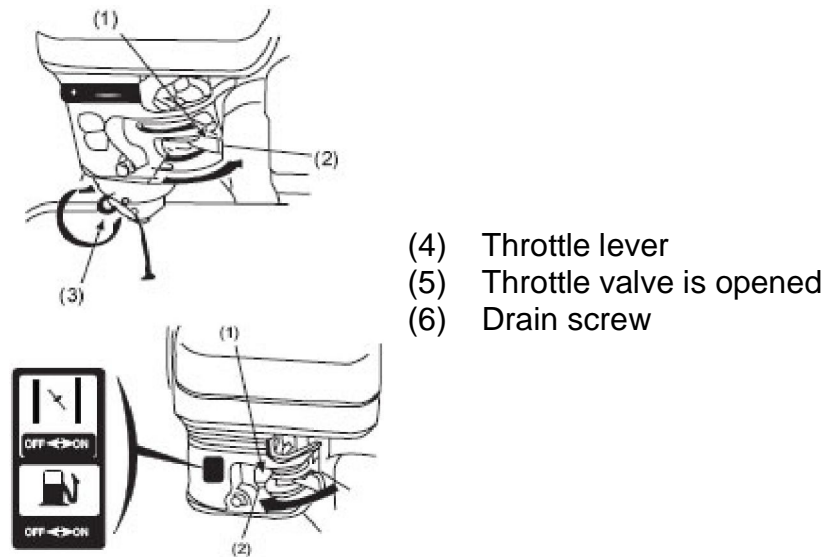

- (4) Throttle lever
- (5) Throttle valve is opened
- (6) Drain screw

The engine may be run only within the rated power and rated speed. If you detect abnormal episodes, please stop the engine immediately and initiate corrective measures. The engine should not be charged during the first 1-3 minutes after the start!

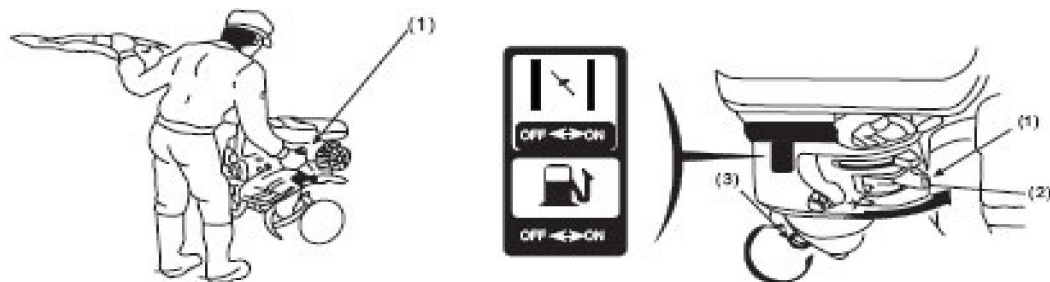

- (4) Choke
- (5) Choke not activated
- (6) Carburattor drain screw

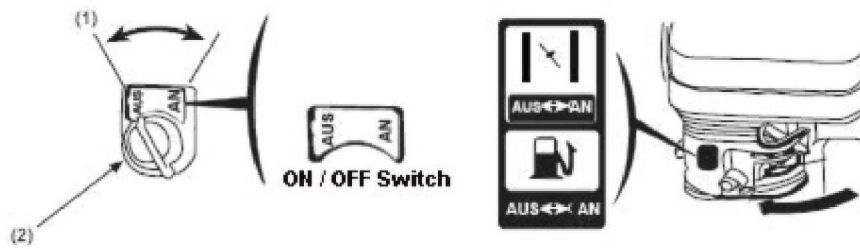

- (3) Ignition „OFF“
(4) Ignition switch

If you want to stop the engine, reduce the speed to a minimum, set the choke to "OFF" and rotate the "On / Off switch to " Off ", the engine should be shut immediately. The switch is located right on the crankshaft housing.

Regular maintenance

- Clean the air filter regularly and replace it, if it is not clean anymore. It should be cleaned after approximately 25 hours of working.
- Check all fittings for tightness and tighten them, if necessary!
- Check the engine oil level regularly.

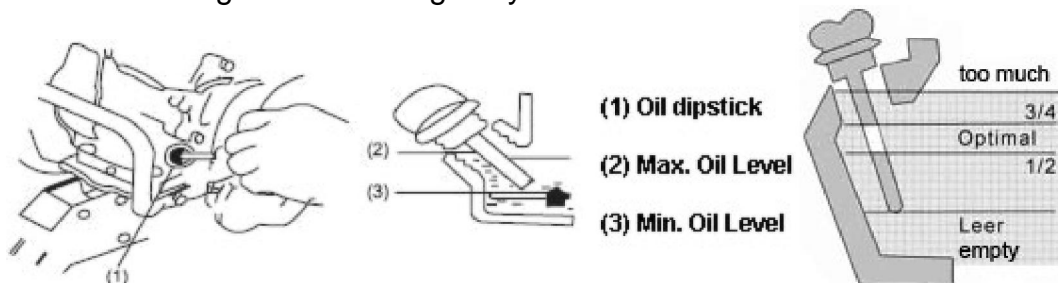

Every 50 hours of operation the spark plug should be cleaned, tested, or replaced if necessary. If the earth electrode is burnt too strong or the spark plug worn, it should be exchanged against a new spark plug of the same type. **Only mount or dismount spark plugs in a cold engine! Use ONLY ORIGINAL spark plugs!**

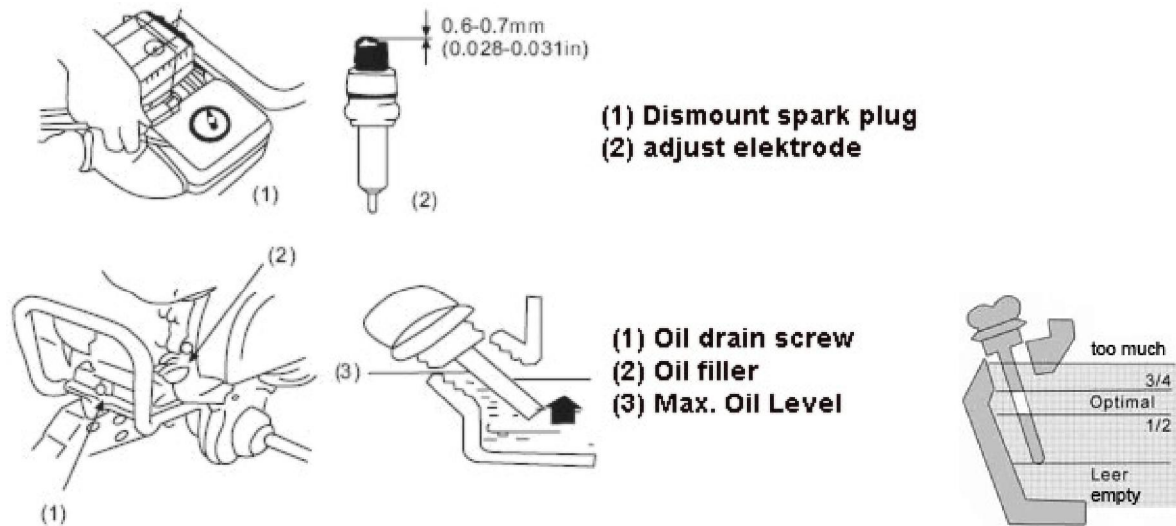

Clean the fuel tank every 100 hours of operation. This tank should be taken from the holder and rinsed. The fuel filter should periodically be cleaned.

If the engine shall be stored for long periods of time, the fuel tank shall be completely emptied and the carburettor emptied on his discharge screw (3). The engine oil should be discharged, when the engine is hot, but switched off (!) Then fill in new oil. The engine should be completely cleaned of dirt from the outside. The air filter and spark plug should be checked again and replaced or cleaned, if necessary. The combustion chamber should be filled with some motor oil when the spark plug is unscrewed, so that the combustion chamber is not oxidized.

After that, the engine may be stored in a dry storage place.

Torques

Part	Nm		
	152F-160	168	177-192
Cylinder head screws	24	25±1	34±1
Crankshaft case screws	14±1	24±1	
Connecting rod bolt	11±1	23±1	
Fly wheel screws	50	75 – 85	110 – 120
Spark plugs	20		
Spark plug gap	0,6 – 0,7mm (0,024 – 0,028in)		
Valve clearance (cold)	IN: 0,15 +/- 0,02mm EX: 0,20 +/- 0,02mm		

Technical Data

Engine designation:	168-2	177	188	190
Engine type:	4 stroke, 1 cylinder, air cooled, OHV, gasoline engine			
Displacement (cc):	196	270	389	420
Spark plug:	F6TC	F6TC	F6TC	F7TC
Max. power:	4,8 kW / 6,5 PS Bei 3600 U/min.	6,8 kW / 9 PS Bei 3600 U/min.	9,6 kW / 13,0 PS bei 3600 U/min.	10,5 kW / 15 PS Bei 3600 U/min.
Starting device	E –start/ recoil start			
Engine oil type:	SAE 15W/40 mineral for Winter / Summer			
Fuel consumption (g/kW/h):	<374g	<374g	<374g	<374g
Fuel type:	Super unleaded			
Fuel tank capacity (super unleaded in l):	3,6	6	6	6
Engine oil capacity (in l):	0,6	1,1	1,1	1,10
Cooling	Air cooled engine			
Gross weight	16 kg	25 kg	33 kg	34 kg
Size in cm:	41,7 x 36,8 x 38,5	54 x 50 x 51	54,2 x 50,0 x 50,7	485x455x525
Bore x stroke (in mm):	68 x 54	77x 58	88 x 64	90 x 66
Ignition:	Transistor / Magneto			
Engine stop system:	Circuit to ground			