

**HYUNDAI**  
POWER PRODUCTS



# YARD WEEDER HYYW70

## Instruction Manual

**⚠ YOU MUST read and understand the full safety instruction manual first.**

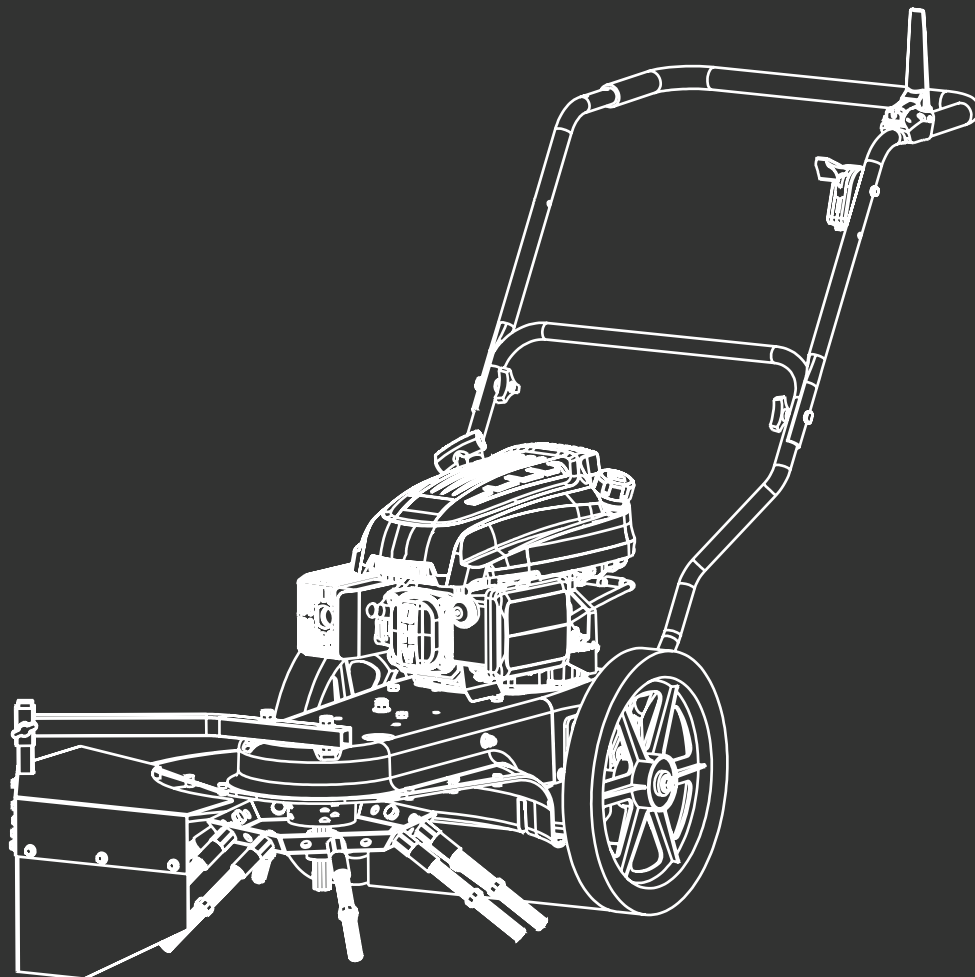

# Introduction

## Thank You For Purchasing Your HYUNDAI Product

We work very hard to give all of our customers the best possible service. If you have any problems, before leaving negative feedback, please contact us to give us a chance to resolve the issue. We would be delighted if you left us positive feedback! Thank you for purchasing this product.

## Important!



**⚠WARNING : READ THE INSTRUCTION BOOKLET THOROUGHLY BEFORE USING THE MACHINE.** Keep for future reference and pass it on if the machine is loaned or sold to another user.

This manual has been produced by Hyundai Power Products and should be kept with the product. Please read and understand these instructions before you use your product. Failure to do this may result in personal injury or damage to the product.

The safety precautions and warnings are to ensure your safety and protect you from harm or damage to the product.

The information contained in this manual was accurate at the time of production, however HYUNDAI Power Products may make modifications to the product without notification.

# Contents

<b>Features</b> .....	<b>4-5</b>	<b>Useful Information</b> .....	<b>31</b>
<b>Unboxing</b> .....	<b>6</b>	Our YouTube Channel.....	31
Unboxing Safety.....	6	Warranty.....	31
Box Contents.....	6	Manual Updates.....	31
<b>Assembly</b> .....	<b>6-11</b>	Returning Your Product.....	31
Assembly Safety.....	6	Leaving A Review.....	31
Assemble Handle Bars.....	7	Ordering Spare Parts.....	31
Attach Clutch Handle.....	7	<b>Contact Us</b> .....	<b>32</b>
Mount The Wheels.....	8	<b>Product Information</b> .....	<b>33</b>
Attach The Brushes.....	8	Information.....	33
Mount The Gas Lever.....	9	Service Record.....	33
Mount The Protection Frame.....	10	<b>Notes</b> .....	<b>34</b>
Mount The Start Cord.....	11	<b>Declaration Of Conformity</b> .....	<b>35</b>
<b>Preparation</b> .....	<b>12-13</b>		
Adding Oil.....	12		
Checking Oil Level.....	12		
Changing / Draining Oil.....	12		
Adding Fuel.....	13		
<b>Starting / Stopping</b> .....	<b>14-16</b>		
Before Each Use.....	14		
Starting.....	15		
Stopping.....	16		
After Each Use.....	16		
<b>Operating</b> .....	<b>17</b>		
Brush Height Adjustment.....	17		
<b>Maintenance</b> .....	<b>18-25</b>		
Maintenance Safety.....	18		
Checking Your Machine.....	18		
Maintenance Schedule.....	19		
Cleaning.....	20		
Transportation.....	21		
Storage.....	22-23		
Spark Plug.....	24		
Air Filter.....	25		
<b>Troubleshooting</b> .....	<b>26</b>		
<b>Technical Data</b> .....	<b>27-28</b>		
Specifications.....	27		
Spare Parts.....	28		
<b>Recycling And Disposal</b> .....	<b>29</b>		
<b>Our Product Range</b> .....	<b>30</b>		

## Contact Us



[www.hyundaipowerproducts.co.uk](http://www.hyundaipowerproducts.co.uk)



01646 687 880



[aftersales@hyundaipowerproducts.co.uk](mailto:aftersales@hyundaipowerproducts.co.uk)

# Features

## HYYW70 Features

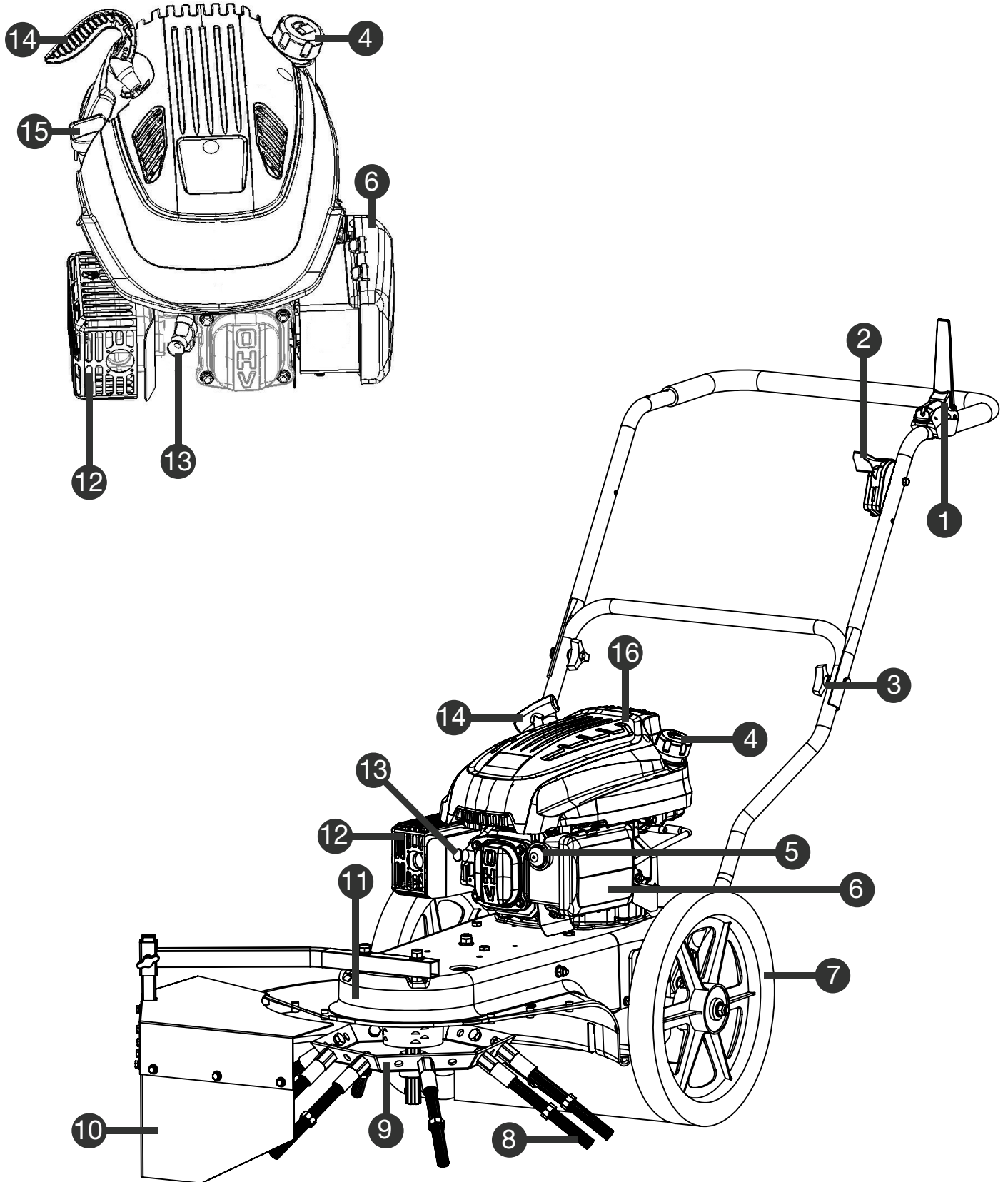

# Features

## HYYW70 Feature Explanations

- 1 Brush Activation Handle**  
Control rotating brush.
- 2 Throttle Lever**  
Control engine speed.
- 3 Handle Knob**  
Use this to adjust and tighten the handle bars.
- 4 Fuel Tank Cap**  
Fill fresh unleaded petrol here.
- 5 Primer Button**  
Injects fuel directly into the carburettor for cold starts.
- 6 Air Filter**  
Prevents dust, dirt and other contaminants from getting into the engine.
- 7 Wheel**  
Two large heavy-duty wheels.
- 8 Brush**  
Rotating brush.
- 9 Brush Head**
- 10 Brush Guard**
- 11 Base Plate**
- 12 Exhaust**  
WARNING - HIGH TEMPERATURE
- 13 Spark Plug**
- 14 Start Cord**  
Pulling the starter grip operates the recoil starter to start the engine.
- 15 Dipstick / Oil Filler Cap**  
Fill engine oil here.
- 16 Engine**  
173cc Hyundai engine.

# Unboxing

## ⚠ Unboxing Safety

⚠ **WARNING!** Unboxing and assembling the machine should be done on a flat, stable surface with enough room. Disposal of the packaging should be done in accordance with the local regulations in force.

Carefully remove the product from the packaging and examine it for any sign of damage caused during shipping. Lay the contents out and check them. If any part is damaged or missing, you must not use the machine. Contact HYUNDAI Power Products immediately. You must keep the packaging material in case the machine needs to be returned or repaired.

⚠ **WARNING!** Some of the packaging material may be harmful to children. Keep out of reach of children.

Ensure that you have all the accessories and tools you need for assembly and operation including the suitable personal protective equipment.

## Box Contents

- User Manual
- Safety Manual
- HYYW70

## ⚠ Assembly Safety

⚠ **CAUTION** - This guide is meant to serve as a quick reference for operating your HYUNDAI machine. We always advise reading the manual in full before operation.

⚠ **CAUTION** - For OUTDOOR use ONLY. Petrol machines produce carbon monoxide – poisonous, colourless and odourless gas that can cause serious injury or death. Petrol is highly flammable, always handle with extreme care and in a well ventilated area.

⚠ **NOTE** - Images may vary depending on model.

⚠ **NOTE** - The machine can be supplied with some parts already assembled. Prior to assembly, check all items have been received.

⚠ **NOTE** - This machine is shipped without fuel and oil and MUST be filled before use. Failure to do so may cause damage to the engine that will not be covered by warranty.

**We recommend that you fill out the information on page 33. If you need to contact an authorised dealer or customer service for information on servicing, you may need to provide this information.**

**There is also a service record so you can keep track of your machine service dates.**

# Assembly

## Step 1 : Assemble Handle Bars

Mount lower handlebar with 4 bolts on the console. After that mount the upper handlebar. The spacers need to be on the inside (as shown).

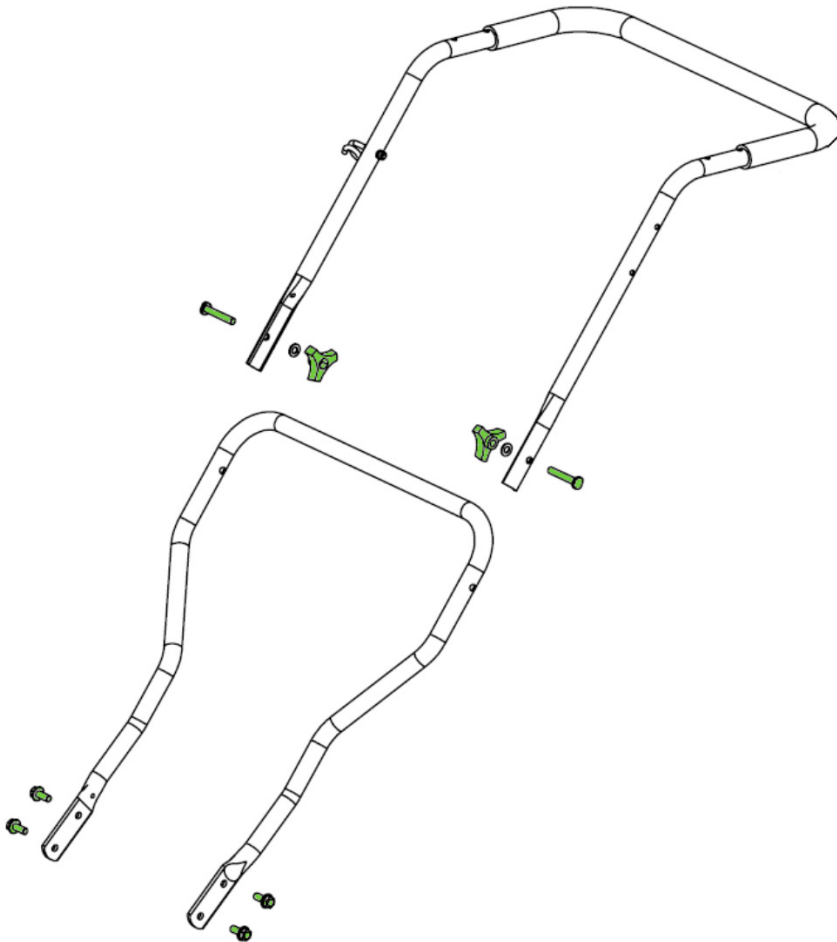

## Step 2 : Attach Clutch Handle

Attach the clutch handle on the handlebar, (as shown).

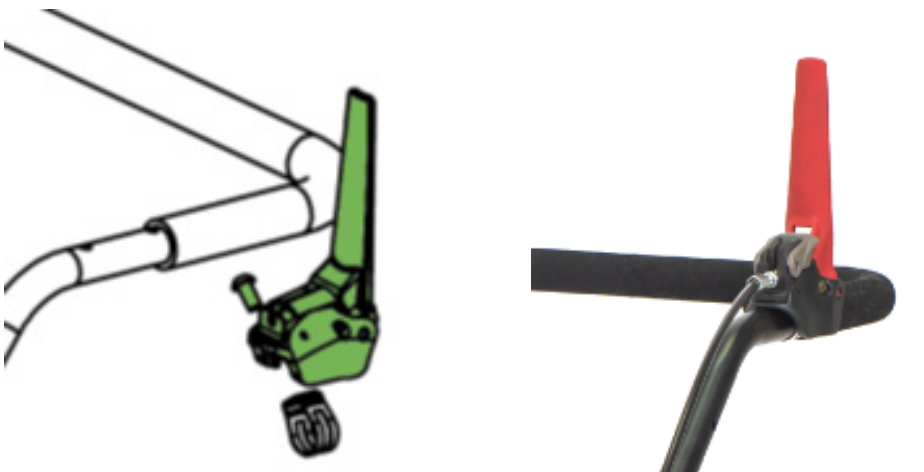

Contact Us

# Assembly

## Step 3 : Mount The Wheels

Mount the wheels with the bolts (as shown). The spacers need to be between the wheel and the console.

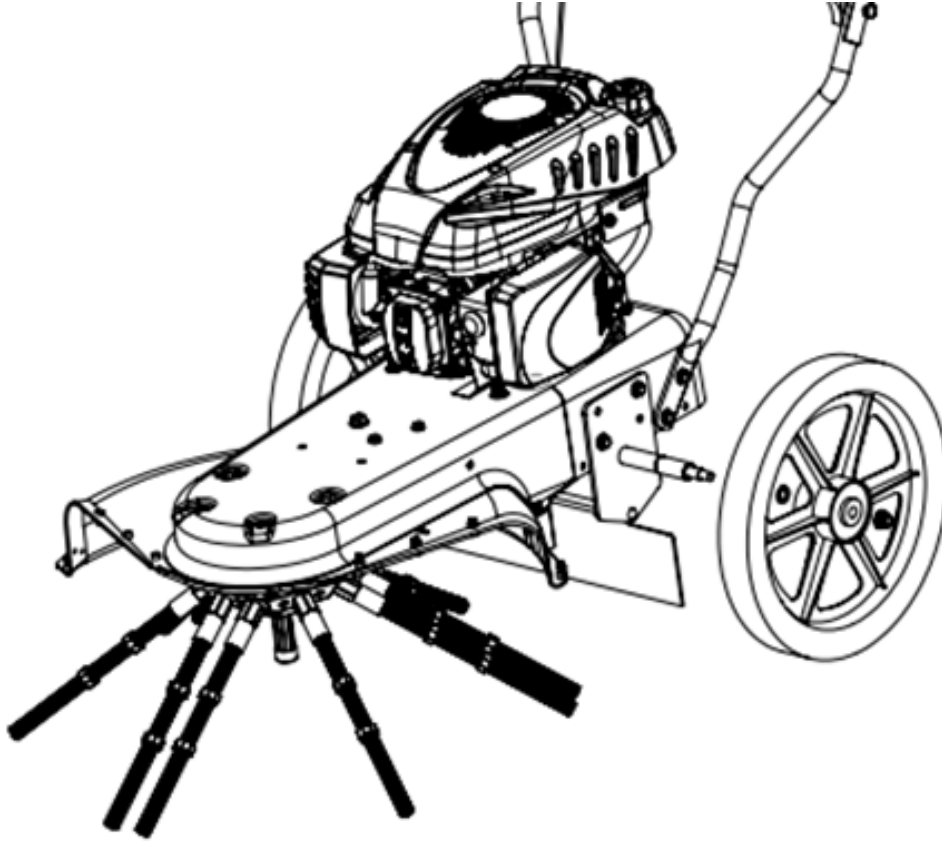

## Step 4 : Attach The Brushes

Attach the brushes using the bolts and lock washers as shown.

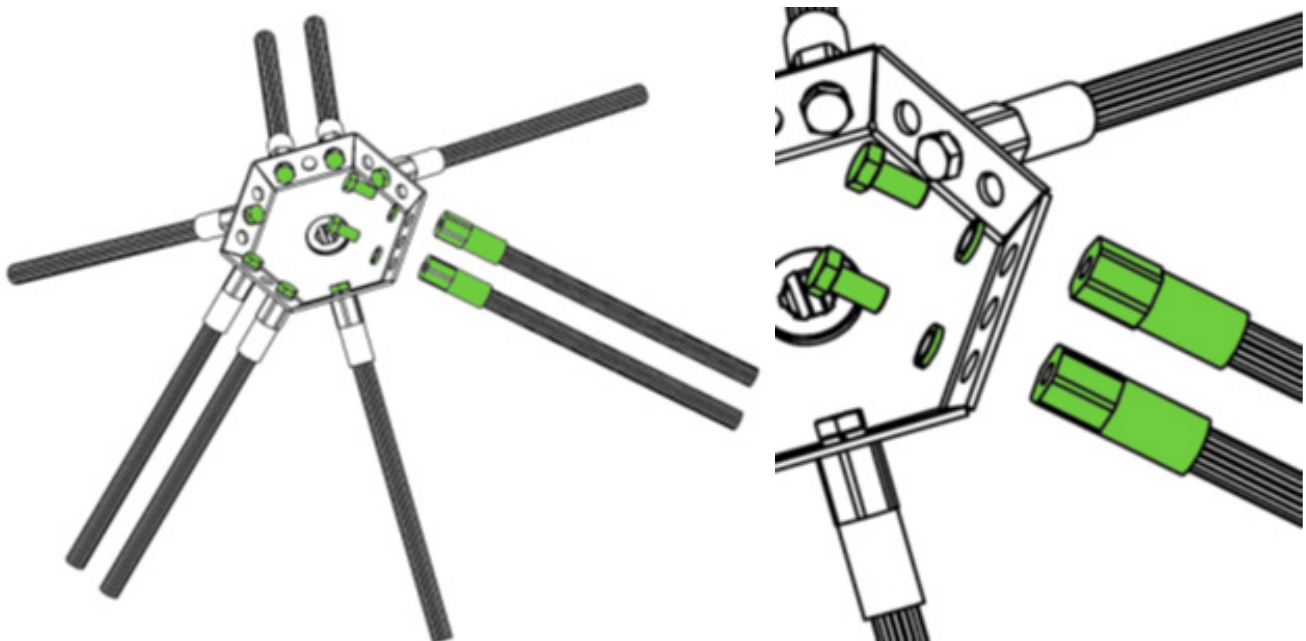



# Assembly

## Step 5 : Mount The Gas Lever

Mount the throttle lever on the handle, as shown.

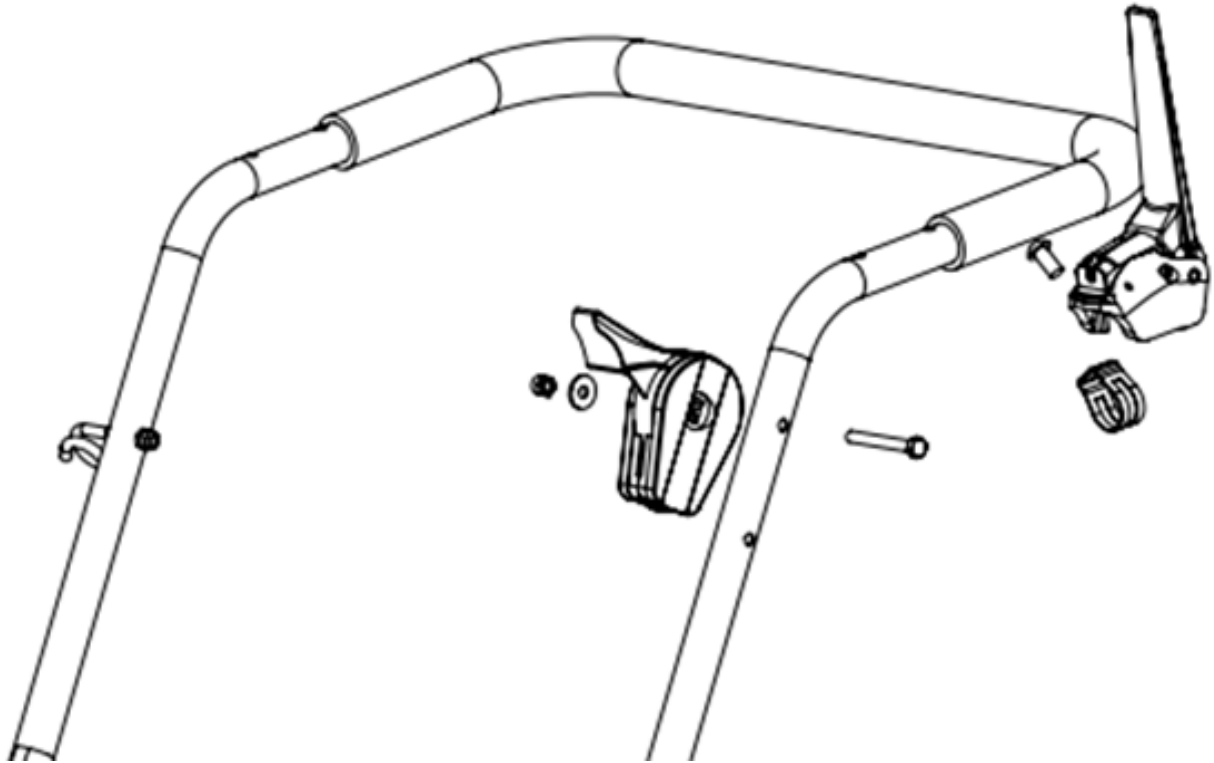

# Assembly

## Step 6 : Mount The Protection Frame

Attach the transparent cover to the frame with bolts (image 1).  
Mount the frame on the machine as shown (image 2).

1

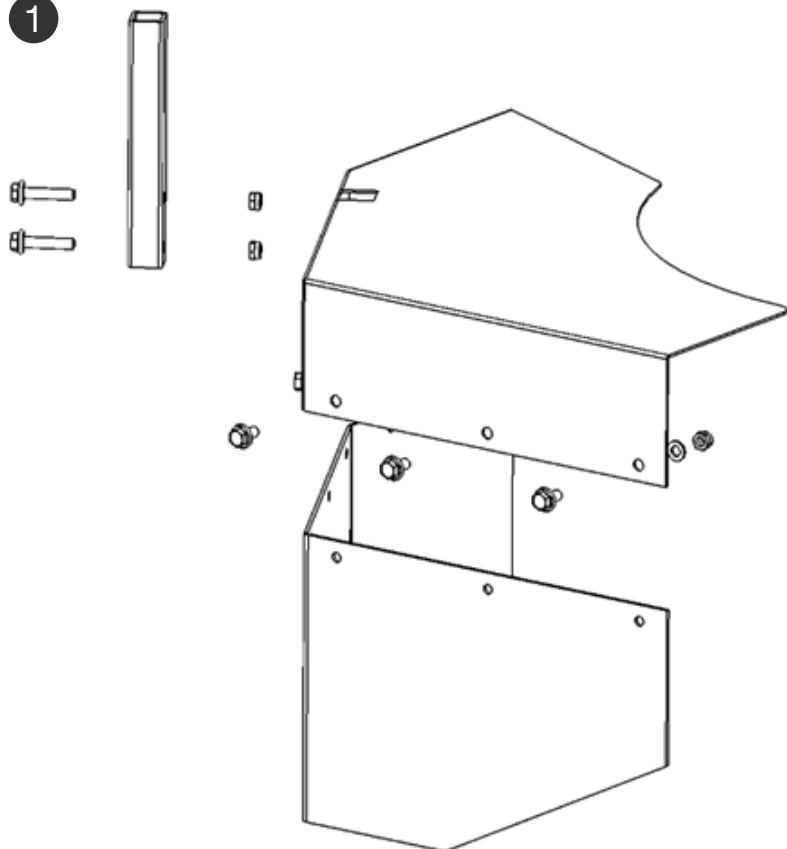

2

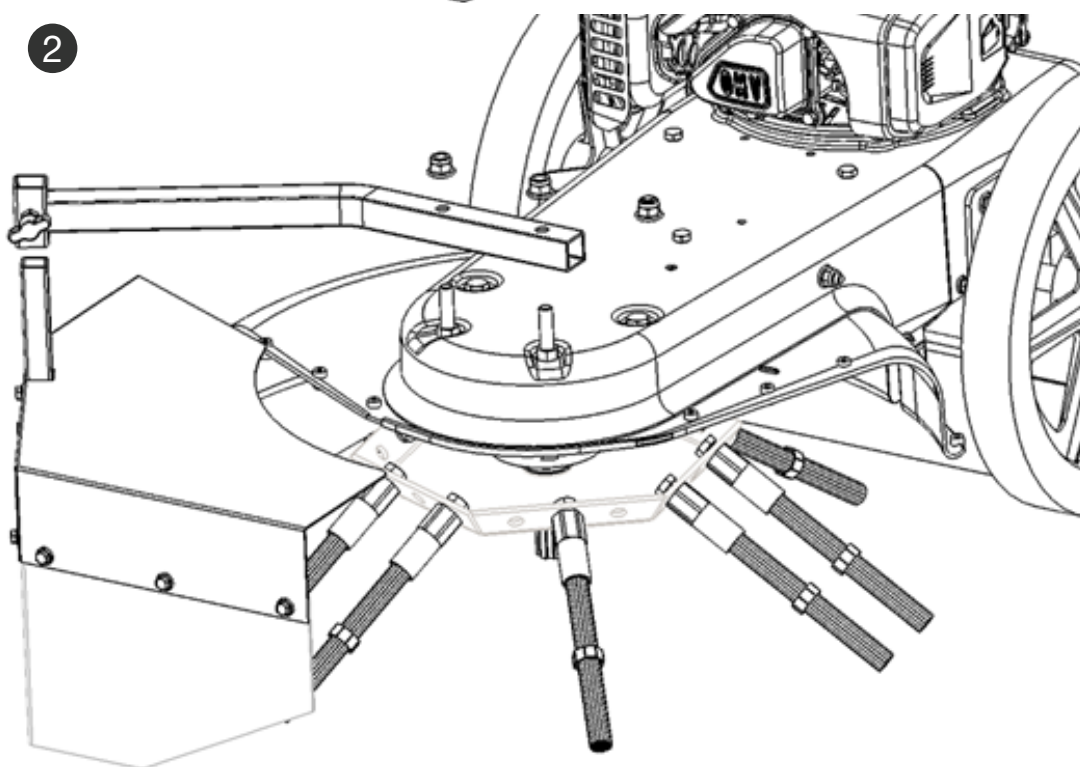

# Assembly

## Step 7 : Mount The Start Cord In Holder

Pull the start cord gently from the engine. Attach the starter grip on the holder on the handlebar.

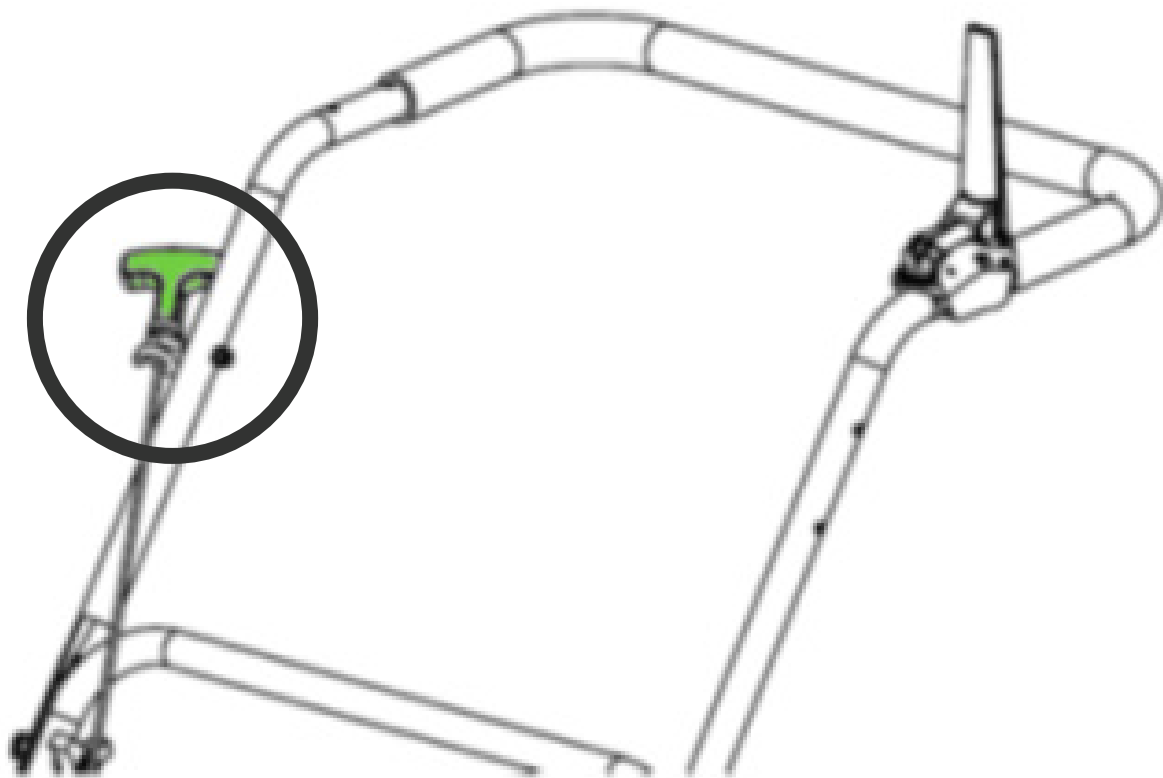

# Preparation

## Adding Oil

Oil Type : SAE 30 or 15w40 Engine Oil  
Oil Capacity : 600ml

**NOTE** - The machine is delivered without oil in the engine. All machines are tested and inspected so there may be some residual oil left in the machine so please fill with caution.

- 1 Remove the oil filler cap.
- 2 Fill with fresh SAE 30 or 15W40 engine oil to the upper mark on the dipstick. DO NOT overfill.
- 3 Once the correct amount of oil has been added, refit the dipstick securely.

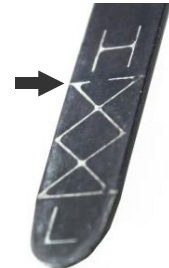

## Checking Oil Level

- 1 Remove the oil filler cap and wipe the dipstick clean.
- 2 Remove the dipstick and check the oil level. It should be up to the upper mark on the dipstick.
- 3 If the oil level is too low, add SAE 30 or 15W40 engine oil to the upper mark on the dipstick. DO NOT overfill. The oil level should not be above the upper mark on the dipstick. If you do overfill, read the 'Changing / Draining Oil' section below for more information on draining oil.
- 4 Once the correct amount of oil has been added, refit the dipstick securely.

## Changing / Draining Oil

**To reduce fire hazards, check there is no oil and/or fuel leaks on a regular basis.**

It is highly recommended to change the engine oil every 100 hours or 12 months. This will ensure the machine will function properly over time.

There are different ways you can empty the oil:

- The oil can be discharged at a specialised servicing centre.
- You can use an oil syringe to suction the oil out through the filler spout, bearing in mind you may need to repeat the operation several times in order to completely empty the tank.
- Gently tilt the machine with the air filter facing upwards and allow the excess oil to drain from the dipstick port, in to a suitable container.

Remember to top-up with oil before using the machine again.

# Preparation

## Adding Fuel



Make sure you read the fuel safety before handling fuel.

Fuel Type : Fresh Straight Unleaded Petrol  
Fuel Capacity : 1L

**NOTE** - The machine is delivered without petrol. All machines are tested and inspected so there may be some residual petrol left in the machine so please fill with caution.

- 1 Remove the fuel tank cap.
- 2 Fill the fuel tank with fresh straight unleaded petrol. Allow a 25mm gap from the top of the tank, then refit the cap securely. **DO NOT** mix petrol with oil and clean up any spills immediately.

**NOTE** - **DO NOT** overfill. The fuel tank only needs to contain enough fuel to complete the days work. If you run out of fuel, refilling must only be done once the engine has cooled down. Fuel stored within the machine for 28 days or more can go stale and should be drained before further use.

**NOTE** - Make sure not to drip petrol onto the plastic parts to prevent damaging them and remove all traces of spilt petrol immediately. The warranty will not cover damage to plastic parts caused by petrol.

- 3 Refit the fuel filler cap securely and clean up any fuel spilt before starting the engine.



# Starting / Stopping

## Before Each Use

**⚠ YOU MUST read and understand the full safety instruction manual before starting the machine.**

**⚠ CAUTION** - For OUTDOOR use ONLY. Petrol machines produce carbon monoxide – poisonous, colourless and odourless gas that can cause serious injury or death. Petrol is highly flammable, always handle with extreme care and in a well ventilated area.

- 1 Always ensure that the machine is in a safe working condition. Inspect and check safety devices and guards and check all nuts, bolts and screws are secure.
- 2 Check the oil level and fill the fuel tank.
- 3 Make sure you know how to stop the machine and ensure you are familiar with emergency stop.
- 4 Start the machine following the instructions and stay clear of the machine's moving parts.
- 5 Brushes can scratch and damage some tiles. Therefore, run a small test before using the machine.
- 6 Always have the protection frame attached during use.
- 7 The gears are delivered pre-greased. However, always ensure they are well greased before each use.

# Starting / Stopping

## Starting

- 1 Pump the primer bulb 3-6 times. See below.

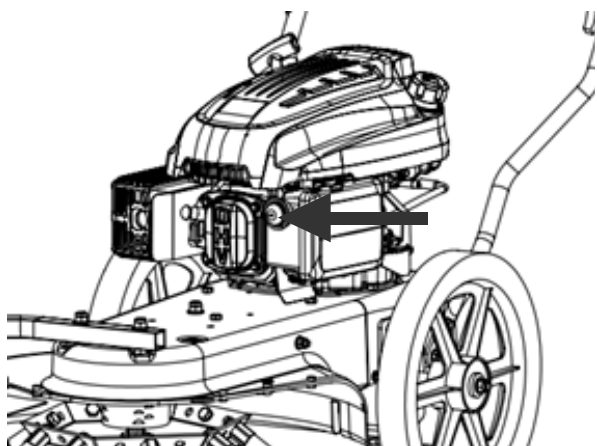

- 2 Set the throttle lever to the max. position.

- 3 Pull the start cord to start the engine. Always feed the start cord back into the engine by hand.

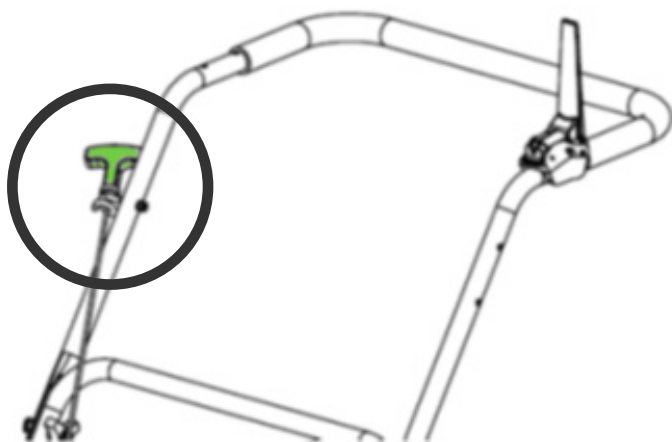

- 4 Activate the brush activation handle.

# Starting / Stopping

## Stopping

- 1 Release the brush activation handle.
- 2 Set the throttle lever to the stop position.

**⚠ CAUTION** - Vibrations may travel up into the handle during use. We therefore recommend taking a break every two hours.

## After Each Use

- 1 Examine the machine for damage.
- 2 Clean the machine if necessary.



## Brush Height Adjustment

It is possible to adjust the height on the brush head down in several positions as the brushes get worn.

To adjust the height, you have to loosen the two 4mm screws shown below. Then you can adjust the brush head up and down. Tighten both screws again once the desired height is chosen.

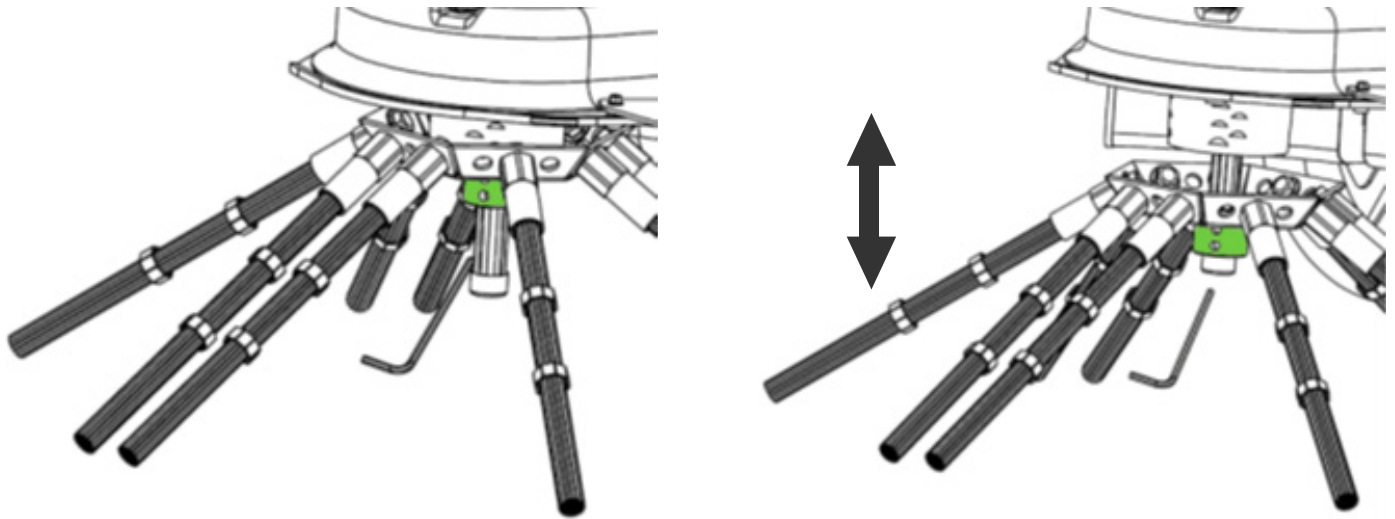

Make sure to adjust the protection frame upwards too as the brushes get worn and when the brush head is adjusted down. Or else the rubber cover will be damaged.

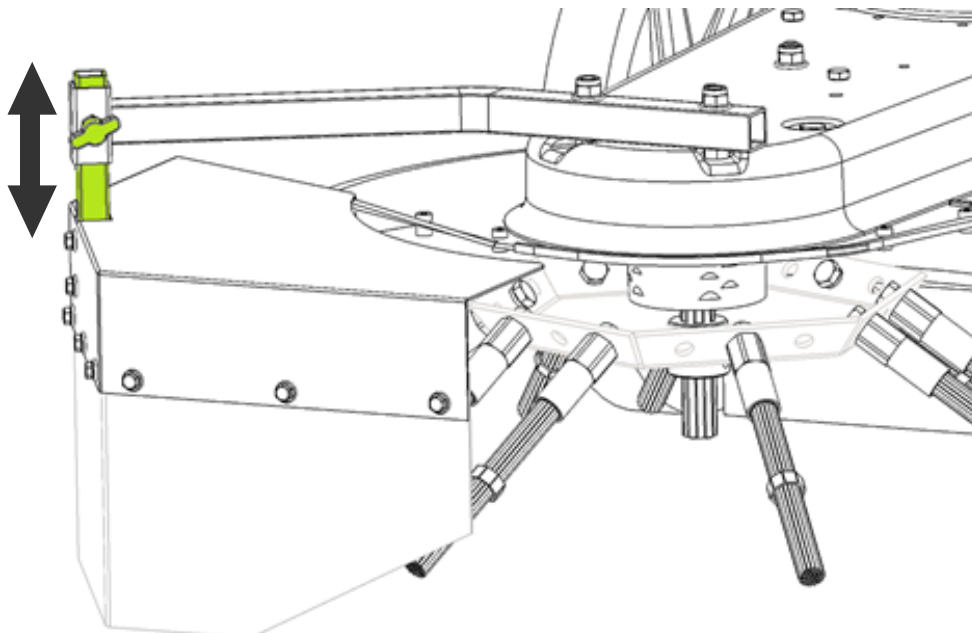

# Maintenance

## ⚠ Maintenance Safety

**⚠ IMPORTANT** - Routine and accurate maintenance is essential for maintaining original machine safety and performance levels.

**⚠ WARNING** - Before cleaning or doing maintenance work, you need to stop the engine, disconnect the spark plug cable and read the relevant instructions. You need to wear proper clothing and protective gloves whenever your hands are at risk.

**⚠** If there are worn or damaged parts, never use the machine. Faulty or worn-out parts must be replaced and not repaired. You must only use original spare parts. The use of non-original and/or incorrectly fitted parts will jeopardize the safety of the machine. This may also cause accidents or personal injuries for which the manufacturer is under no circumstance liable or responsible.

**⚠** Any maintenance operations or adjustments not explained in this manual must be carried out by your Dealer or a specialised Service Centre with the necessary knowledge and equipment to ensure that the work is done correctly maintaining the machine's original safety level. Any operations performed in unauthorised centres or by unqualified persons will invalidate the Warranty and all obligations and responsibilities of the Manufacturer.

**⚠** Be very careful during adjustment of the machine to prevent entrapment of the fingers between moving parts and fixed parts of the machine.

## Checking Your Machine

When checking your machine, we recommend you:

- Check for worn or damaged parts
- Make sure all nuts, screws and bolts are tight
- Make sure all warning stickers are in place and not damaged
- Check for oil / fuel leaks

# Maintenance

## Maintenance Schedule

Routine and accurate maintenance is essential for maintaining original machine safety and performance levels.

It is recommended that the following maintenance schedule is followed.

Maintenance	Before Each Use	After Each Use	Every 3 Months Or 25 Hours	Every 6 Months Or 50 Hours	Every Year Or 100 Hours	Every Two Years Or 250 Hours
Check Machine. <i>See page 18.</i>	X					
Clean Machine. <i>See page 20.</i>		X				
Change Engine Oil <i>See page 12.</i>					X	
Spark Plug <i>See page 24.</i>				Check	Replace	
Air Filter <i>See page 25.</i>				Clean	Replace	
Drain Fuel And Clean Tank					X	
Check Fuel Pipe For Leaks <i>Take To Dealer.</i>						X
Check Valve Clearance <i>Take To Dealer.</i>						X
Clean Combustion Chamber <i>Take To Dealer.</i>						X



# Maintenance

## Cleaning

 **CAUTION - DO NOT** use a hose pipe or pressure washer to clean the engine. Water can damage the engine or contaminate the fuel system.

 **NOTE** Engine must be switched off and spark plug lead disconnected.

## After Each Use

- You must remove grass and mud from the machine to prevent it from drying. This will cause problems the next time the machine is used.
- Wipe the machine down with a damp cloth.
- For larger build ups of debris, use a scraper or similar product.
- Dry the machine completely to prevent rust from forming.
- Make sure not to drip petrol onto the plastic parts to prevent damaging them and remove all traces of spilt petrol immediately. The warranty will not cover damage to plastic parts caused by petrol.
- Remove the trimmer head from the trimmer axle to remove wedged grass etc from the rotor shaft.

## Regularly

- Paint on internal chassis parts may start to flake over time due to abrasive action of cut grass. If this happens, you should touch-up with rust-proof paint to prevent rusting that could corrode the metal. You can also use a light oil or silicone spray to prevent rust.
- Avoid using solvents when cleaning plastic parts. Most plastics are susceptible to damage from various types of commercial solvents and may be damaged by their use.

## Transportation

Whenever the machine is to be handled, lifted, transported or tilted, you must:







- 1 Wear sturdy work gloves.
- 2 Hold the machine at the points that offer a safe grip, taking into account the weight and relative distribution of the same.
- 3 Use an appropriate number of people for the weight of the machine and the characteristics of the vehicle or the place where it must be placed or collected.
- 4 You must make sure that machine movements do not cause petrol leaks, damage or injuries.
- 5 During transport, make sure to fasten the machine securely with cables or straps.
- 6 The machine must be transported on a flat surface.



# Maintenance

## Storage

### Where To Store

-  Store in a cool, dry place away from sources of ignition and varying changes in temperature.
-  Store on a flat and level surface with all wheels on the ground.
-  DO NOT stack other items on top of the machine when in storage.
-  Store the machine in a safe place, out of the reach of children or anyone who is not familiar with operation.
-  To reduce fire hazards, keep the engine, silencer, and petrol storage area free of grass, leaves, or excessive grease. Do not leave containers full of cut grass inside storage areas.
-  DO NOT store the machine with fuel in the tank in an area where the fuel vapours could reach an open flame, a strong heat source or a spark.
-  DO NOT store a machine that has not been given time to fully cool down. Engine must be cooled down fully before storage.

### Short Term

After use, please follow the below steps before storing your machine.

- 1** Allow the engine to fully cool down.
- 2** Clean the machine. See the 'Cleaning' section.
- 3** Store the machine following the guidelines above.

# Maintenance

## Long Term

If storing the machine for a period of 30 days or more, you must follow proper storage and winterisation guidelines to avoid any possible issues with the machine. Incorrect storage can lead to possible fueling or engine issues that will not be covered by the warranty.

- 1 Allow the engine to fully cool down.
- 2 Drain all the fuel from the fuel tank and then run the machine until it has completely run out of fuel to clear the remaining fuel from the fuel lines and carburettor.
- 3 Drain the oil from the engine.
- 4 With the machine drained from all fluids, follow the cleaning instructions in the 'Cleaning' section.
- 5 Follow the maintenance section and check, service or replace serviceable items if required. Visually inspect the machine and replace or repair any worn parts.
- 6 Lightly grease all moving parts on the machine.
- 7 Refill engine oil with new SAE 30 or 15w40 engine oil, fill to the upper mark on the dipstick.
- 8 Remove the spark plug and pour 1 teaspoon of fresh engine oil down the cylinder bore. Cover the spark plug hole with a lint free clean cloth, ensuring no dirt or debris falls into the cylinder chamber and gently pull the recoil starter handle to coat the cylinder bore with the fresh oil. Refit the spark plug.

## Preparation To Re-Use

- 1 Check oil level before using.
- 2 Check spark plug is inserted correctly.
- 3 Fill engine with fresh unleaded petrol that has not been stored for periods of more than 30 days.



# Maintenance

## Spark Plug

For good performance, the spark plug must be properly gapped and free of deposits.

- 1 You **MUST** allow the engine to cool down before carrying out any maintenance.
- 2 Always replace with the same model spark plug as fitted.
- 3 To check spark plug, remove spark plug cap.
- 4 Remove spark plug using the supplied spark plug wrench.
- 5 Clean the spark plug electrode, making sure that there is no damage to the insulator or electrode.
- 6 The spark plug gap should be 0.70mm to 0.80mm. Check the gap by using a feeler gauge. Adjust as necessary by carefully bending the side electrode to achieve the correct gap.
- 7 Refit the cleaned and adjusted spark plug by hand to avoid cross-threading.
- 8 After spark plug seats then tighten as necessary with a spark plug wrench but avoid over-tightening.
- 9 Re-attach the spark plug cap.



# Maintenance

## Air Filter

**⚠ CAUTION** - A dirty air filter will restrict the air flow to the carburettor, which will reduce engine efficiency.

When using the machine in very dusty areas you must clean or replace the air filter more often. Never operate the machine without the air filter being fitted it can cause damage to the engine which is not covered by warranty.

- 1 To gain access to the air filter press the 2 cover tabs.
- 2 Remove filter, check for contamination and clean or replace as required.
- 3 Clean the filter by tapping it several times on a hard surface to remove dirt, or blow air through it using an air gun not exceeding 30psi.
- 4 Also clean the foam pre-filter. Wash in detergent and let dry.
- 5 Never use a brush to clean the filter it will only drive dirt into the fibres of the filter.

Wipe dirt from the air cleaner body by using a moist rag, be careful to prevent dirt or debris entering in to the carburettor.

- 6 Reinstall the filter and cover.

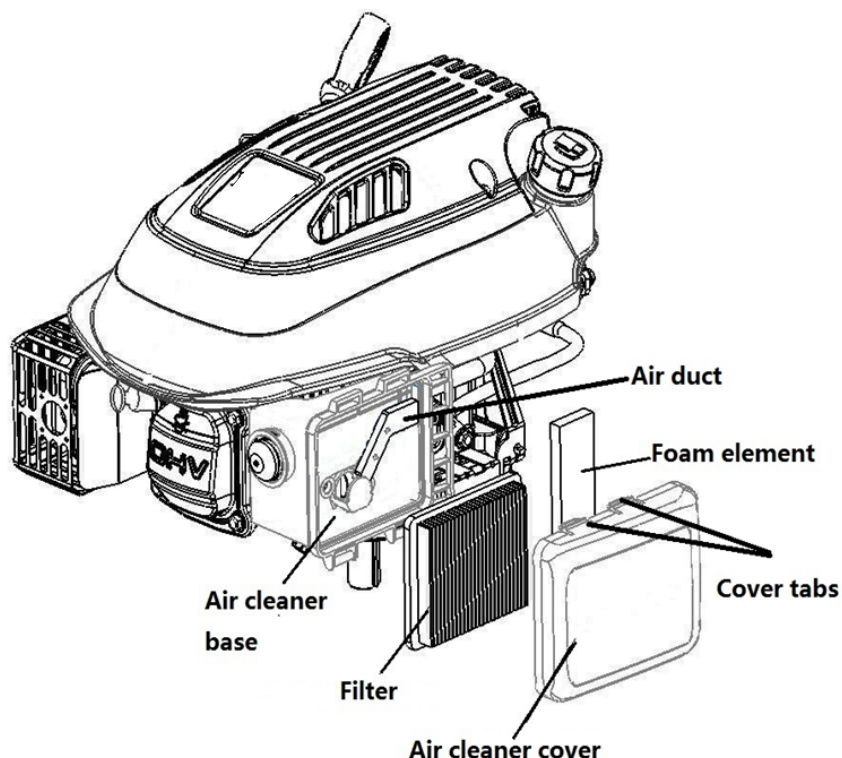

## Contact Us



# Troubleshooting

Problem	Possible Cause	Possible Solution
Engine does not start	<ul style="list-style-type: none"> <li>❶ Spark plug disconnected.</li> <li>❷ Engine not primed.</li> <li>❸ Defective or incorrectly gapped spark plug.</li> <li>❹ Fuel tank empty or low.</li> <li>❺ Dirty carburettor or fuel line.</li> <li>❻ Carburettor dirty.</li> <li>❼ Engine flooded.</li> <li>❽ Throttle control lever incorrect position.</li> <li>❾ Stale petrol.</li> <li>❿ Defective throttle control lever or wire.</li> <li>⓫ Dirty air filter.</li> </ul>	<ul style="list-style-type: none"> <li>❶ Connect spark plug.</li> <li>❷ Prime engine.</li> <li>❸ Inspect or replace spark plug.</li> <li>❹ Add fuel.</li> <li>❺ Clean carburettor or fuel line.</li> <li>❻ For carburettor cleaning, take the unit to an authorised service centre.</li> <li>❼ Wait several minutes before starting.</li> <li>❽ Move throttle lever to correct position.</li> <li>❾ Drain oil fuel and add fresh petrol.</li> <li>❿ Inspect lever and wire. Replace if damaged or defective.</li> <li>⓫ Clean or replace air filter.</li> </ul>
Engine runs poorly	<ul style="list-style-type: none"> <li>❶ Bad spark plug.</li> <li>❷ Dirty air filter.</li> <li>❸ Carburettor out of adjustment.</li> <li>❹ Stale petrol.</li> </ul>	<ul style="list-style-type: none"> <li>❶ Replace spark plug.</li> <li>❷ Replace air filter.</li> <li>❸ Adjust carburettor. Take the unit to an authorised service centre.</li> <li>❹ Drain old petrol and replace with fresh fuel.</li> </ul>
Engine Overheats	<ul style="list-style-type: none"> <li>❶ Engine cooling system clogged.</li> <li>❷ Carburettor out of adjustment.</li> <li>❸ Oil level is low.</li> </ul>	<ul style="list-style-type: none"> <li>❶ Clean debris system, engine screen and cooling fins.</li> <li>❷ Adjust carburettor. Take the unit to an authorised service centre.</li> <li>❸ Add oil.</li> </ul>
Poor trimming performance	<ul style="list-style-type: none"> <li>❶ Trimmer line length is too short.</li> </ul>	<ul style="list-style-type: none"> <li>❶ Replace the line.</li> </ul>
Trimmer vibrates	<ul style="list-style-type: none"> <li>❶ Set screws for trimmer head is loose.</li> <li>❷ Trimmer line lengths are substantially different.</li> <li>❸ Loose nuts or bolts.</li> <li>❹ Broken trimmer head.</li> </ul>	<ul style="list-style-type: none"> <li>❶ Tighten set screws.</li> <li>❷ Adjust trimmer line to approximately equal lengths.</li> <li>❸ Check all bolts and nuts, including engine bolts.</li> <li>❹ Replace broken part.</li> </ul>

# Technical Data

## Specifications

<b>Model</b>	<b>HYYW70</b>
Engine Type	IC175
Engine Size	173cc
Engine Power	3kW
Max. Engine Speed	2800rpm
Fuel Tank Capacity & Fuel Type	1L Unleaded Petrol
Oil Capacity & Oil Type	600ml SAE30 or 15W40
Rated Speed	2800rpm
Drive Type	Push
Start Method	Recoil
Height Adjustment	Yes
Brushes	9 Pieces
Working Width	70cm
Wheel Size	14"
Measured Sound Level	104dB(A)
Guaranteed Sound Level	104dB(A)
Vibrations	4.51m/s <sup>2</sup>
Net Weight	43kg



# Technical Data

## Spare Parts

Only use original spare parts: The use of non-original and/or incorrectly fitted parts will jeopardize the safety of the machine, may cause accidents or personal injuries for which the Manufacturer is under no circumstance liable or responsible.

Part	Part Number
Wheel	HYYW70WHEEL
Recoil Assembly	IC175RECOIL
Nylon Brush	HYYW70BRUSH
Engine Oil SAE 30 or 15W40	600MLSAE30OIL

# Recycling And Disposal

## Recycling And Disposal



We do not offer a takeback scheme for the recovery of Waste Electrical Electronic Equipment (WEEE) & Batteries. Instead the responsibility to dispose of WEEE and/or Batteries is passed onto you by us.

So when it becomes necessary to dispose of your machine you must take it to your local Civic Amenity Site. For further information please contact your local Authority for disposal advice.

You **MUST** make sure that all unused oil and fuel is disposed of correctly either beforehand or at your local Civic Amenity Site.

- Under NO circumstances must any fuel or oil be put down any drains.
- Certain products contain WEEE waste which should not be disposed of in your domestic waste.
- You **MUST** recycle WEEE in accordance with your local authority or recycling centre.
- Certain products contain batteries which should not be disposed of in your domestic waste.
- You **MUST** recycle batteries in accordance with your local authority or recycling centre.
- Unwanted packaging and materials should be stored and taken to a recycling centre so it can be disposed of in a manner which is compatible with the environment.

We are a Member of the VALPAK National Compliance Scheme and our registration number is **RM08660**. For further information about disposal please contact your Local Authority.

You can also get more advice and guidance about recycling at the following website  
<http://www.recycle-more.co.uk>

Should you pass this product on to another user either sold or loaned, you **MUST** pass on this user manual. This will make sure that all other users can use and maintain this machine safely.

## Environmental Protection

1. Environmental protection should be a priority of considerable importance when using the machine, for the benefit of both social coexistence and the environment in which we live. Try not to cause any disturbance to the surrounding area.
2. You must comply with local regulations and provisions for the disposal of packaging, oils, petrol, filters, damaged parts or any elements which have a strong impact on the environment. This waste must not be disposed of as normal waste. It needs to be separated and taken to specified waste disposal centres where the material will be recycled.
3. You must comply with local regulations for the disposal of waste materials after mowing.
4. When disposing, do not pollute the environment with the machine, but hand it over to a disposal centre, in accordance with the local laws in force.

## Contact Us



[www.hyundaipowerproducts.co.uk](http://www.hyundaipowerproducts.co.uk)



01646 687 880



[aftersales@hyundaipowerproducts.co.uk](mailto:aftersales@hyundaipowerproducts.co.uk)

# Our Product Range

## Generators

Leisure Inverter, Petrol, Diesel And Built-In Motorhome Generators

## Pressure Washers

Petrol, Diesel And Electric Pressure Washers

## Water Pumps

Submersible, Clean And Dirty Water And Professional Chemical Water Pumps

## Lawnmowers

Petrol, Cordless, Electric, Roller, Self Propelled, Electric Start And Robotic Lawnmowers

## Grass Trimmers And Brush Cutters

Petrol, Cordless, Electric And Wheeled Grass Trimmers And Brush Cutters

## Chainsaws

Petrol, Cordless And Electric Chainsaws

## Hedge Trimmers

Petrol And Cordless Hedge Trimmers

## Leaf Blowers

Petrol, Electric, Cordless, Backpack And 3 -in-1 Leaf Blowers

## Log Splitters

Horizontal, Vertical, Petrol And Electric Log Splitters

## Wood Chippers

Petrol And Electric Start Wood Chippers

## Tillers

Petrol Garden Tiller And Cultivator

## Earth Augers And Trenchers

Petrol Earth Augers And Heavy Duty Trenchers

## Compactor Plates

Petrol Compactor Plates

## Cement Mixers

Portable Electric Cement Mixers

## Mini Dumpers

4-Wheel Drive Mini Dumpers And Tracked Dumpers

## Yard Sweeper

Self Propelled Yard Sweeper Power Brush

## Scarifiers

Petrol Lawn Scarifier And Aerator

## Stump Grinders

Petrol 4-Stroke Stump Grinders

## Welders And Plasma Cutters

MIG, TIG, MMA, ARC Welders And Plasma Cutters

## Power Tools And Tool Chests

Electric And Cordless Power Tools And Filled Tool Chests

## Vacuum Cleaners

Wet And Dry Vacuum Cleaners

## Engines

Petrol And Electric Start Engines

## Battery Chargers / Starters

6V, 12V, 24V Battery Chargers, Jump Starters And Hydraulic Floor Jack

## Air Compressors

Home, Domestic, DIY And Professional Use Air Compressors

## Lighting Towers

Mobile Lighting Towers With Diesel Generators

## Portable Power Stations

Camping Power Packs And Solar Chargers

## And More

We Are Constantly Expanding Our Range With New Products

If you would like more information on any of these products, please contact our sales team on 01646 687880 or visit our website [www.hyundaipowerproducts.co.uk](http://www.hyundaipowerproducts.co.uk)

# Useful Information

## Check Out Our YouTube Channel

Our videos on YouTube include:

- Unboxing
- Assembly of your machine
- How to service your machine
- Products in use
- 'How To' videos
- Product features

Go to [www.hyundaisupport.co.uk](http://www.hyundaisupport.co.uk) or search 'Hyundai Power Products' in YouTube.

## Warranty

Proof of purchase will be required before you make a warranty claim.

Full warranty terms and conditions can be found on the HYUNDAI POWER PRODUCTS website: [www.hyundaipowerproducts.co.uk](http://www.hyundaipowerproducts.co.uk)

## Manual Updates

Our manuals are constantly being reviewed and updated. Should you find an error, omission or something unclear, please contact us for assistance.

We reserve the right to make any modifications without prior notice whenever necessary.

Our latest manuals are also placed online.

All our manuals can be downloaded at: [www.hyundaipowerproducts.co.uk](http://www.hyundaipowerproducts.co.uk)

## Returning Your Product

If you are returning your product, please contact the dealer for their returns policy.

## Leaving A Review

We work very hard to give all of our customers the best possible service. If you have any problems, before leaving negative feedback, please contact us to give us a chance to resolve the issue. We would be delighted if you left us positive feedback!

To leave a review, please go to: [uk.trustpilot.com/review/hyundaipowerequipment.co.uk](http://uk.trustpilot.com/review/hyundaipowerequipment.co.uk)

## Ordering Spare Parts

Only use original spare parts: The use of non-original and/or incorrectly fitted parts will jeopardize the safety of the machine, may cause accidents or personal injuries for which the Manufacturer is under no circumstance liable or responsible.

## Contact Us



# Need Help? Talk To Our Experts

## Contact Us

**Our friendly aftersales team will be more than happy to help you.**

### **Phone**

Call our team on 01646 687880, open Monday-Friday 8.30am-5pm.

### **Email**

[aftersales@hyundaipowerproducts.co.uk](mailto:aftersales@hyundaipowerproducts.co.uk)

### **Online Live Chat**

Go to [www.hyundaipowerproducts.co.uk](http://www.hyundaipowerproducts.co.uk)

Live chat is open Monday-Friday from 8.30am-5pm.

### **Post**

Genpower Limited, Isaac Way, Pembroke Dock, Pembrokeshire, SA72 4RW, UK.



# Product Information

## Information

As soon as you have purchased the machine, we recommend that you fill out the following. If you need to contact an authorised dealer or customer service for information on servicing, you may need to provide the following information.

The model number and serial number can be found on the grey specification sticker on your machine.

Date Of Purchase: .....

Dealer Name:.....

Dealer Phone:.....

Model Number:.....

Serial Number:.....

## Service Record

### 1st Service

Date Of Service.....

Next Service Due.....

### 2nd Service

Date Of Service.....

Next Service Due.....

### 3rd Service

Date Of Service.....

Next Service Due.....

### 4th Service

Date Of Service.....

Next Service Due.....

## Contact Us



[www.hyundaipowerproducts.co.uk](http://www.hyundaipowerproducts.co.uk)



01646 687 880



[aftersales@hyundaipowerproducts.co.uk](mailto:aftersales@hyundaipowerproducts.co.uk)



# Declaration Of Conformity

## EC Declaration of Conformity

We hereby declare that the machine detailed in this declaration complies to all the relevant provisions of the following EC directives.

- 2006/42/EC The Machinery Directive
- 2014/30/EU Annex II Electromagnetic Compatibility Directive
- 2016/1628/EC The Emission of Gaseous and Particulate Pollutants from internal Combustion engines
- 2000/14/EC Noise Emissions in the Environment by Equipment for use Outdoors.

And is in conformity with the applicable requirements of the following documents:

- EN ISO 3744:2010
- EN ISO 11094:1991
- EN ISO 12100:2010
- EN ISO 1679-1:1988/A1:2011
- EN ISO 14982:2009
- EN ISO 14910:2007/A1:2009

Declaration for 2000/14/EC Noise Emissions in the Environment by Equipment for use Outdoors.

Notified Body for EC Directive 2000/14/EC TÜV SUD (Shanghai) Co., Ltd.

Model	Type	Cutting Width	Measured Sound Power	Guaranteed Sound Power	Engine Speed (rpm)
HYFT60SP	Petrol Field Trimmer	600mm	104dB(A)	104dB(A)	2800
HYYW70	Petrol Yard Weeder	700mm	104dB(A)	104dB(A)	2800

### Product Details:

Brand: Hyundai

Model: HYFT60SP, HYYW70

Description: Petrol Rotary Trimmer

### Name and address of technical documentation holder and EU distributor:

Genpower Ltd, Isaac Way, Pembroke Dock, Pembrokeshire, SA72 4RW, UK.

Signed by: 

Roland Llewellyn, Managing Director

Date: 06/07/2020

## Contact Us



[www.hyundaipowerproducts.co.uk](http://www.hyundaipowerproducts.co.uk)



01646 687 880



[aftersales@hyundaipowerproducts.co.uk](mailto:aftersales@hyundaipowerproducts.co.uk)

# HYUNDAI

POWER PRODUCTS

Importer:  
GENPOWER LTD  
Isaac Way, London Road,  
Pembroke Dock, UNITED KINGDOM, SA72 4RW  
T: +44 (0) 1646 687 880 F: +44 (0) 1646 686 198  
E: [info@hyundaipowerproducts.co.uk](mailto:info@hyundaipowerproducts.co.uk)  
[www.hyundaipowerproducts.co.uk](http://www.hyundaipowerproducts.co.uk)

Imported/Distributed by Genpower Ltd for The United Kingdom & Ireland

Licensed by Hyundai Corporation, Korea