

- Montageanleitung
- Assembly instructions
- Notice de montage
- Montagehandleiding

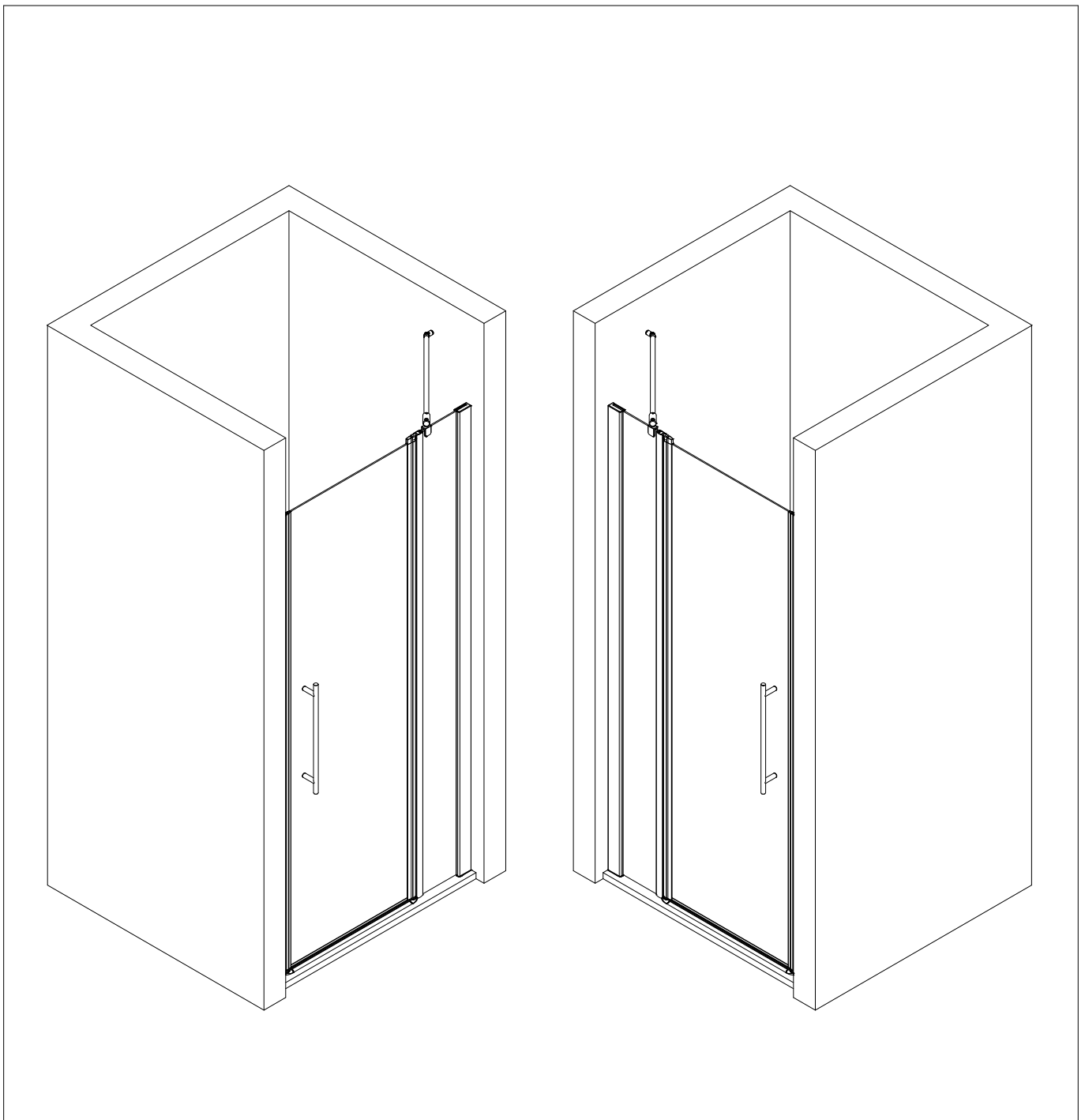

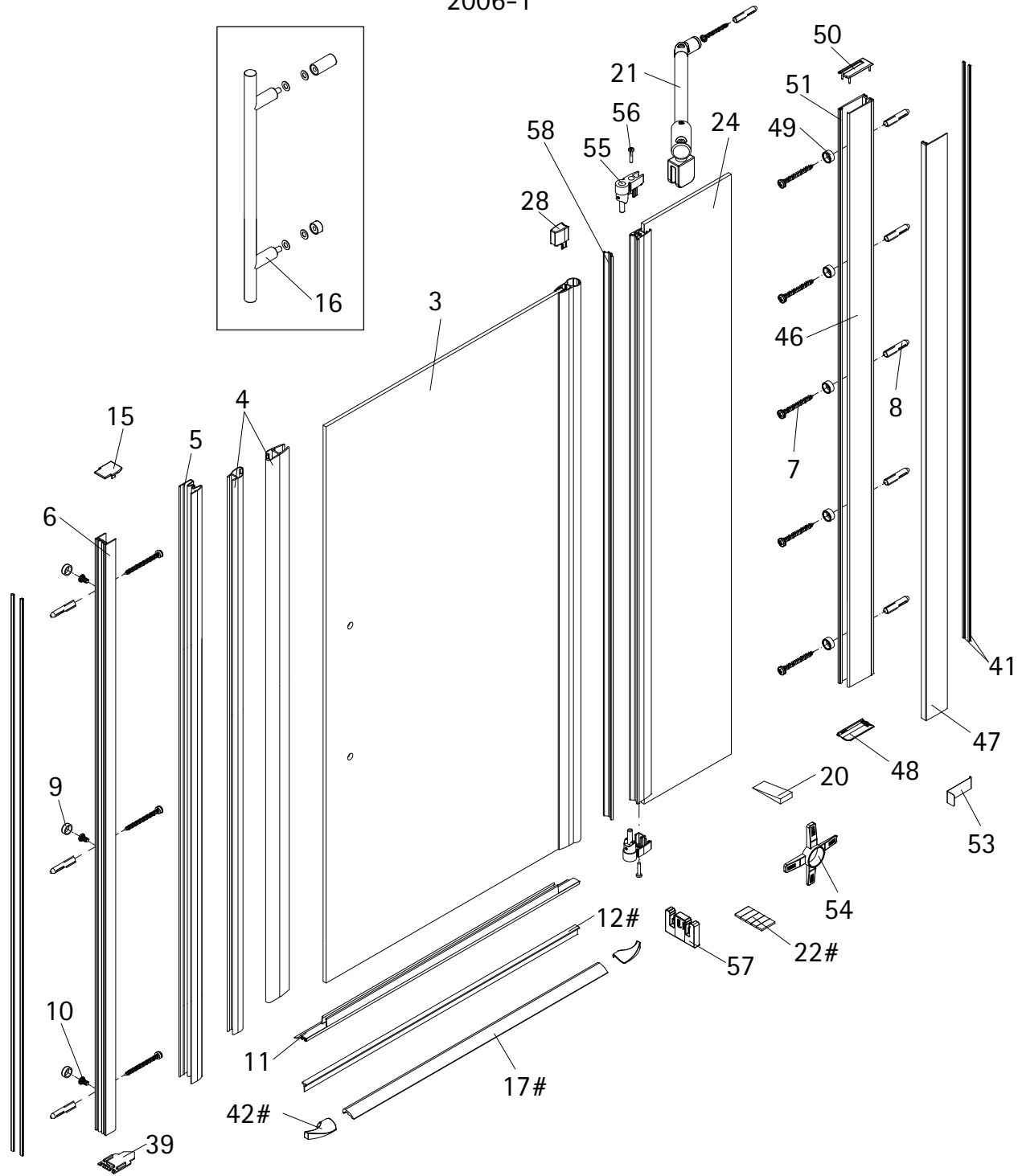

Pos.	Bezeichnung	Ersatzteil-Nr.	Preis	Pos.	Bezeichnung	Ersatzteil-Nr.	Preis
3	1 x Türelement			39*	1 x Silikonpad		
4	2 x Magnet Türelement 45°	E32055	Set 34,95 €	41	4 x Bürstendichtung	E32071	Paar 26,95 €
5	1 x Magnetaufnahmeprofil	E32236	Stück 37,95 €	42#	2 x Endkappe Wasserleiste		
6	1 x Wandanschlußprofil Magnetaufnahmeprofil	E32232	Stück 37,95 €	46	1 x Wandanschlußprofil (inkl. Pos. 51)	E32248	Stück 69,00 €
7*	8 x Blechschraube 4,2 x 45 mm			47	1 x Klemmprofil	E32249	Stück 29,00 €
8*	8 x Dübel S6			48*	1 x Silikonpad SW		
9*	3 x Abdeckkappe für Kappenschraube			49*	5 x Glasschutz		
10*	3 x Kappenschraube 3,5 x 9,5 mm			50*	1 x Abdeckkappe		
11	1 x Wasserabweisprofil (inkl. Pos. 12)	E32058	Set 24,95 €	51	1 x Klemmdichtprofil (vormontiert)		
12#	1 x Einschubdichtung	E32067	Stück 11,95 €	53	1 x Demontagehebel	E32201-3	Stück 27,95 €
15*	1 x Abdeckkappe			54	1 x Montagekeil	E32201-2	Stück 7,95 €
16	1 x Griff, komplett	E32140-26	Stück 79,95 €	55	2 x Drehlager (inkl. Pos. 56+58)	E32080-1	Stück 14,95 €
17#	1 x Wasserleiste (inkl. Pos. 22, 42)	E32050	Set 27,95 €	56*	2 x Blechschraube 3,5x19 mm		
20	1 x Silikonkeile (6 Stk.)	E32203	Satz 13,95 €	57*	2 x Montagehilfe	E32201-1	Stück 7,50 €
21	1 x Stabilisationsbügel, komplett	E32320	Stück 29,95 €	58	1 x Dichtprofil		
22#	1 x Klebestreifen						
24	1 x Festes Element						
28*	1 x Kappe für Drehlager						
					* Schrauben- und Abdeckkappenset	E32200	35,95 €
					# optional		

EN

Pos.	description
3	1 x door elements
4	2 x magnet door elements 45°
5	1 x Magnet retaining profile
6	1 x wall connection profile Magnet retaining profile
7*	8 x countersunk head screw 4,2 x 45 mm
8*	8 x dowel S6
9*	3 x cover caps
10*	3 x screw for cover cap 3,5 x 9,5 mm
11	1 x water-repellent profile (incl. Pos. 12)
12#	1 x pull-in sealing
15*	1 x cover caps
16	1 x handle complete
17#	1 x sealing profile (incl. Pos. 22, 42)
20	1 x silicone wedge
21	1 x stabilizing bar
22#	1 x adhesive stripes
24	1 x fixed panel
28*	1 x cover

F

Pos.	Description
3	1 x porte
4	2 x joint magnétique 45°
5	1 x profilé pour joint magnétique
6	1 x profilé mural de fixation
7*	8 x vis autotaraudeuse 4,2 x 45 mm
8*	8 x cheville S6
9*	3 x capuchon à vis
10*	3 x vis à tête 3,5 x 9,5 mm
11	1 x joint d'étanchéité horizontal bas (incl. Pos. 12)
12#	1 x joint silicone à lèvres souple
15*	1 x cache
16	1 x poignée complète
17#	1 x barre de seuil (Pos. 22, 42 incl)
20	1 x cale de silicone (6 unités)
21	1 x barre de stabilisation
22#	1 x ruban adhésif
24	1 x élément fixe
28*	1 x cache

NL

Pos.	omschrijving
3	1 x deurelementen
4	2 x Magneetsluiting 45°
5	1 x magneetopnameprofiel
6	1 x wandaansluitprofiel
7*	8 x schroef 4,2 x 45 mm
8*	8 x plug S6
9*	3 x afdekkap voor schroef
10*	3 x afdekkapschroef 3,5 x 9,5 mm
11	1 x waterdorpelprofiel (incl. Pos. 12)
12#	1 x inschuifdichting
15*	1 x afdekkapjes
16	1 x greep compleet
17#	1 x dorpelprofiel (incl. Pos. 22, 42)
20	1 x silicone keggen (6 stuk)
21	1 x stabilisatie stang
22#	1 x plakbanden
24	1 x vast element
28*	1 x kap Scharnierdeel

Pos.	description
39*	1 x silicon pad
41	4 x brush seal
42#	2 x end caps sealing profile
46	1 x wall connection profile (inkl. Pos. 51)
47	1 x clamping profile
48*	1 x silicon pad SW
49*	5 x Glass gasket
50*	1 x cover cap
51	1 x inner sealing (pre-assembly)
53	1 x disassembly lever
54	1 x mounting wedge
55	2 x pivot bearings (incl. Pos. 56+58)
56*	2 x Sheet metal screw 3,5x19 mm
57*	2 x assembly aid
58	1 x sealing profile

* kit with screws and cover caps
optional

Pos.	Description
39*	1 x pièce silicone
41	4 x joint à brosse
42#	2 x cache
46	1 x profilé mural de fixation (Pos. 51 incl.)
47	1 x profilé de pincement
48*	1 x pièce silicone (à gauche)
49*	5 x protection en verre
50*	1 x capuchon
51	1 x joint d'étanchéité intérieur (pré-assemble)
53	1 x Levier de démontage
54	1 x cale de montage
55	2 x paliers pivotants (incl. Pos. 56+58)
56*	2 x Vis à tôle 3,5x19 mm
57*	2 x kit de montage
58	1 x profilé d'étanchéité

* kit de vis et caches
en option

Pos.	omschrijving
39*	1 x siliconen pad
41	4 x borstel dichting
42#	2 x eindkap voor aluminium dorpelprofiel
46	1 x wandaansluitprofiel (incl. Pos. 51)
47	1 x klemprofiel
48*	1 x siliconen pad SW
49*	5 x glasbescherming
50*	1 x afdekkaje
51	1 x Dichtstrip binnenzijde (voormonteerd)
53	1 x demontage hendel
54	1 x montage keg
55	2 x draaibare lagers (incl. Pos. 56+58)
56*	2 x Plaatwerkschroef 3,5x19 mm
57*	2 x montagehulp
58	1 x afdichtingsprofiel

* schroeven en afdekkapenassortiment
optioneel

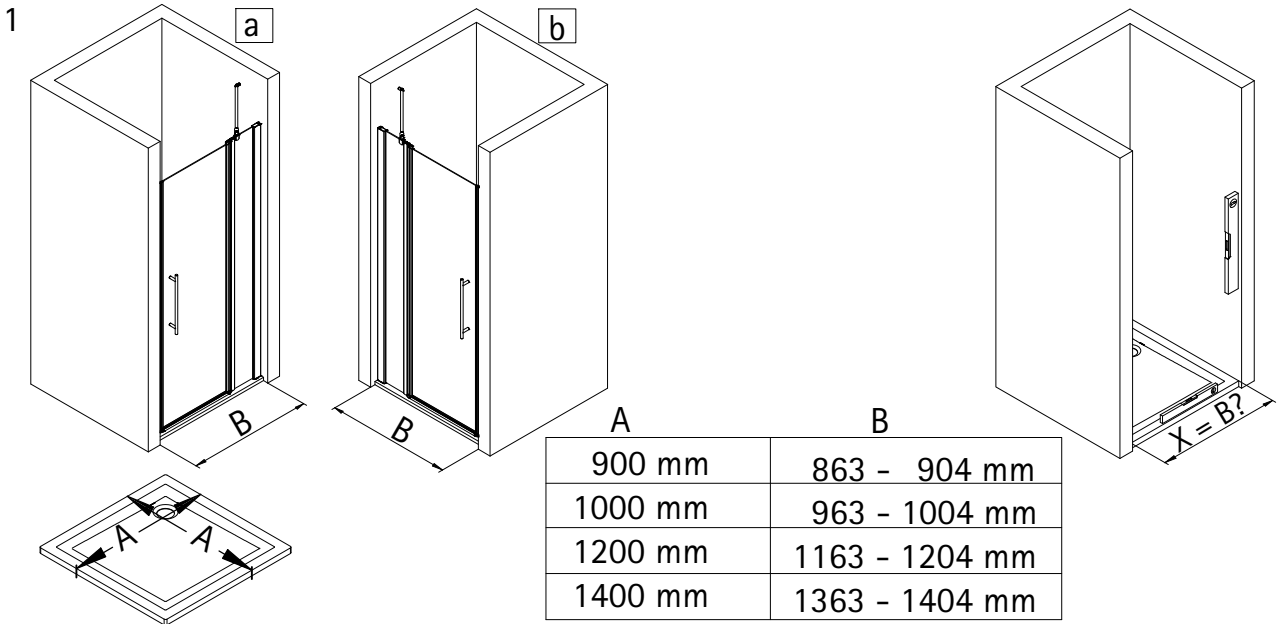
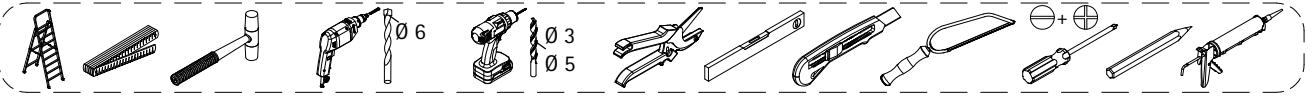
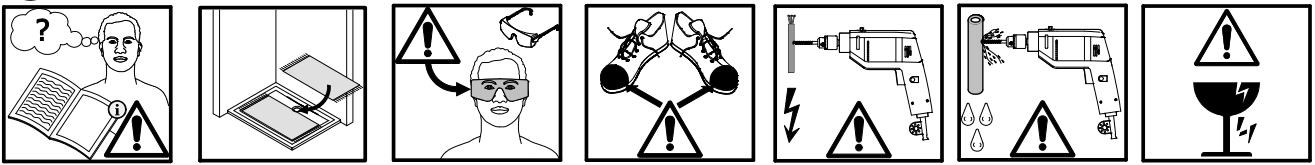

- 2
- (D)** Als ersten Schritt bitte die Bürstendichtung ca. 15 mm aus dem Profil herausziehen, kürzen und wieder einziehen. Oben soll ein Freiraum von ca. 15 mm entstehen, der für die Abdeckkappen benötigt wird
 - (EN)** Firstly pull the brush seal ca 15 mm out of the profile, cut it and insert it again. At the top should be a free space of ca 15 mm, which is needed for the caps.
 - (F)** Retirez environ 15 mm du joint à brosse en haut du profilé. Coupez et renfoncez. Vous devriez alors avoir un petit espace de 15 mm en haut de profilé qui vous permettra de mettre les caches.
 - (NL)** Als eerste stap de borsteldichting ca. 15 mm. Uit het profiel trekken, inkorten en er weer intrekken. Bovenkant moet een vrije ruimte blijven van ca. 15 mm. Welke nodig is voor de afdekkappen.

(i)
oben
top
en haut
boven

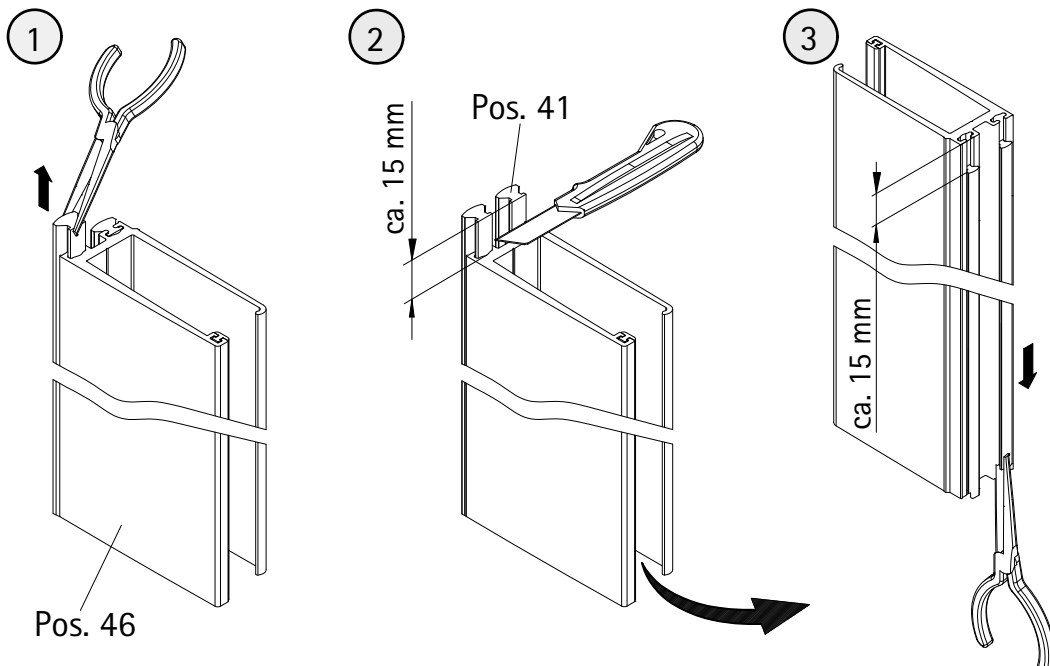

- 3 **D** Als ersten Schritt bitte die Bürstendichtung ca. 6 mm aus dem Profil herausziehen, kürzen und wieder einziehen. Oben soll ein Freiraum von ca. 6 mm entstehen, der für die Abdeckkappen benötigt wird
- EN** Firstly pull the brush seal ca 6 mm out of the profile, cut it and insert it again. At the top should be a free space of ca 6 mm, which is needed for the caps.
- F** Retirez environ 6 mm du joint à brosse en haut du profilé. Coupez et renforcez. Vous devriez alors avoir un petit espace de 6 mm en haut de profilé qui vous permettra de mettre les caches.
- NL** Als eerste stap de borsteldichtung ca. 6 mm. Uit het profiel trekken, inkorten en er weer intrekken. Bovenkant moet een vrije ruimte blijven van ca. 6 mm. Welke nodig is voor de afdekkappen.

i
oben
top
en haut
boven

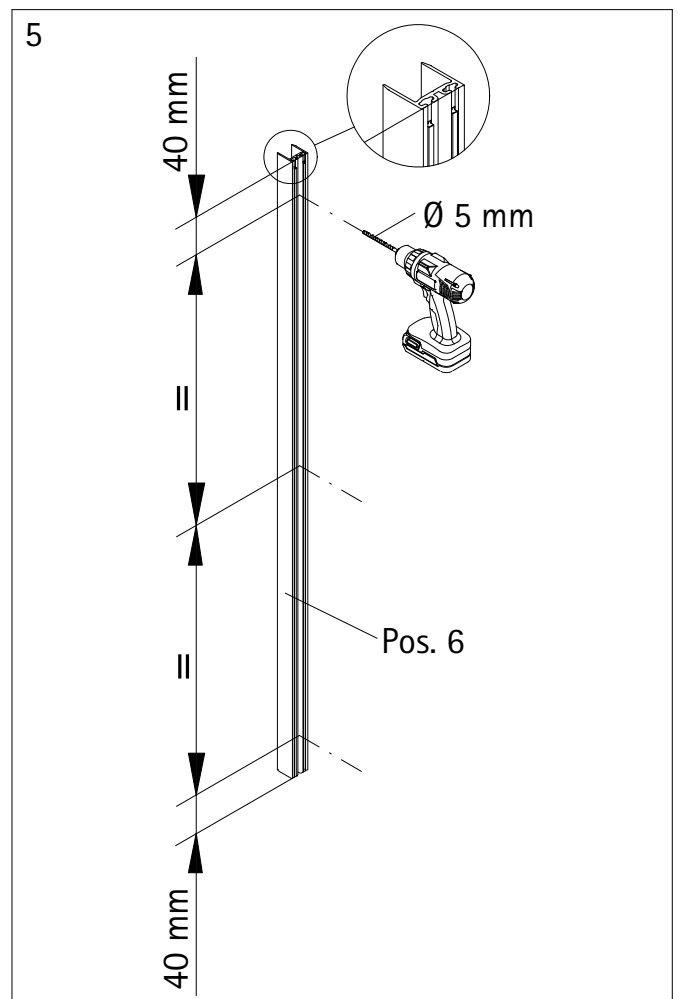
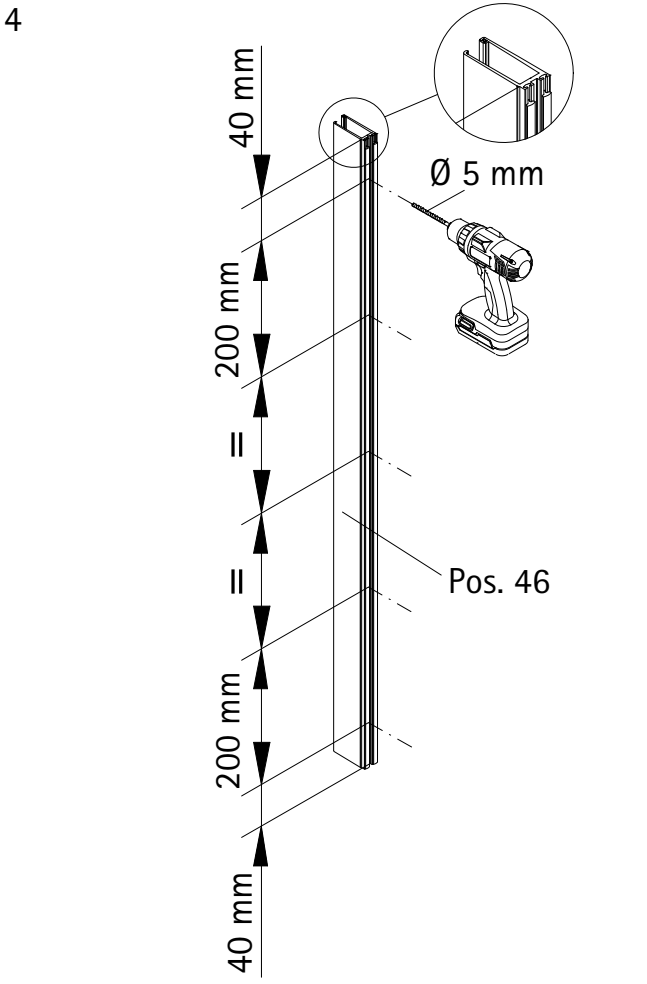
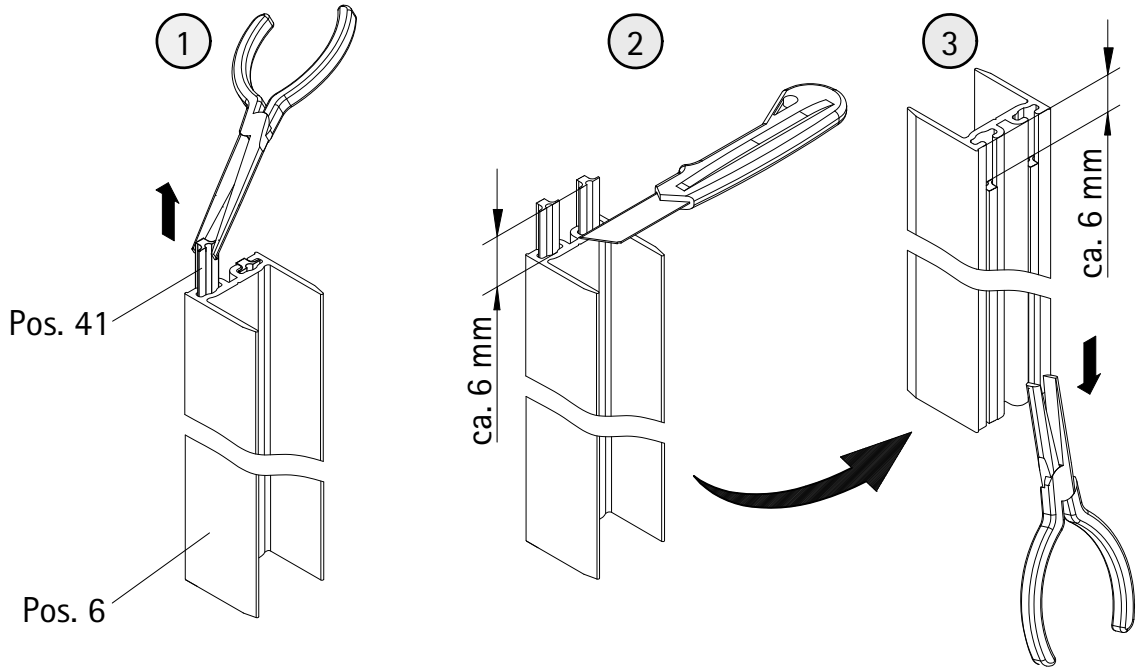

6a

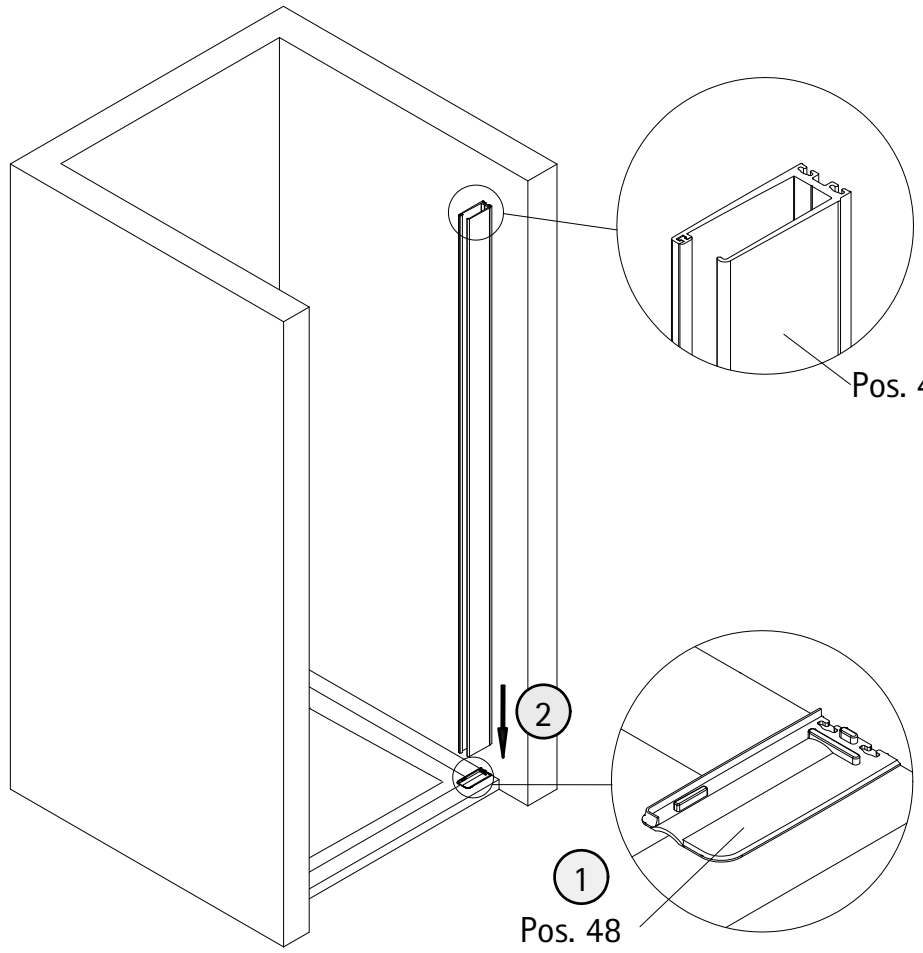
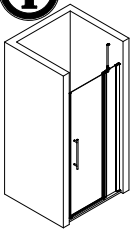

7a

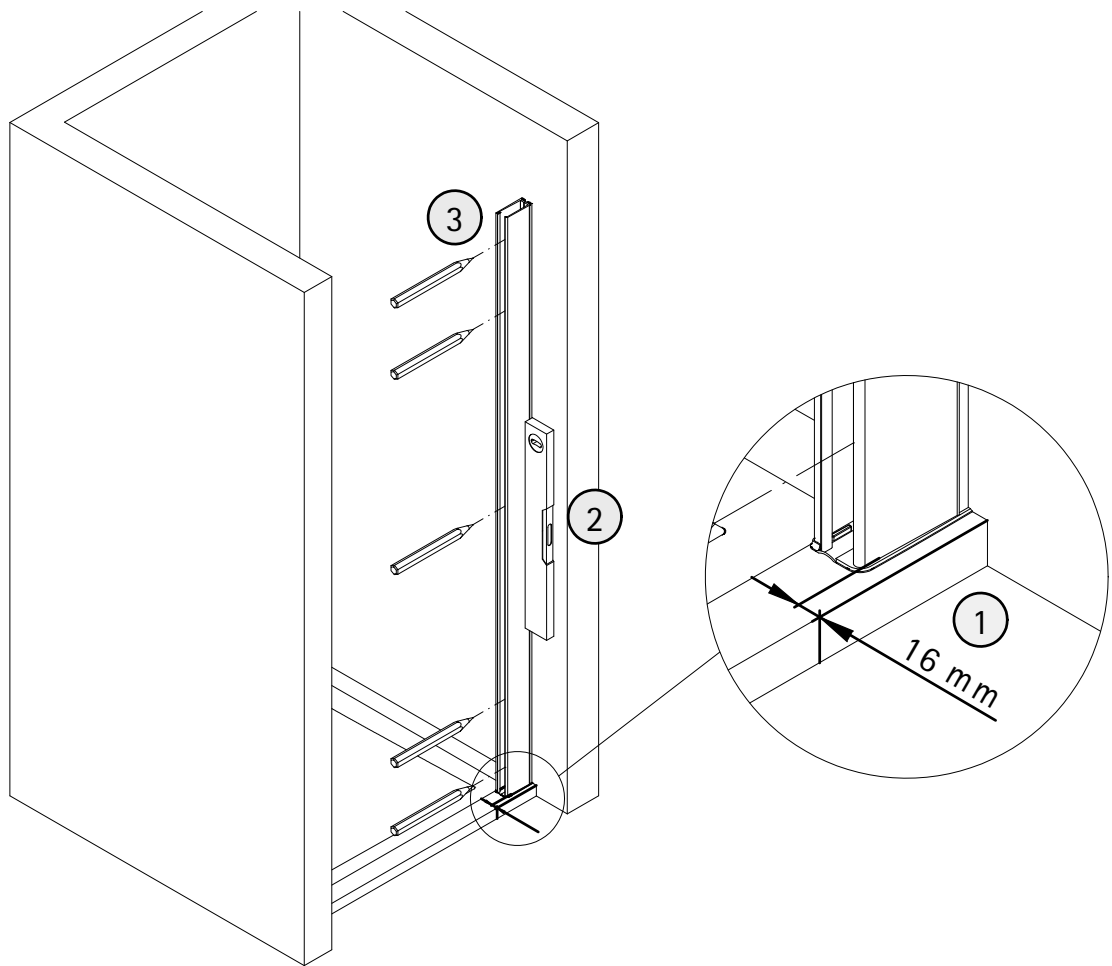

8a

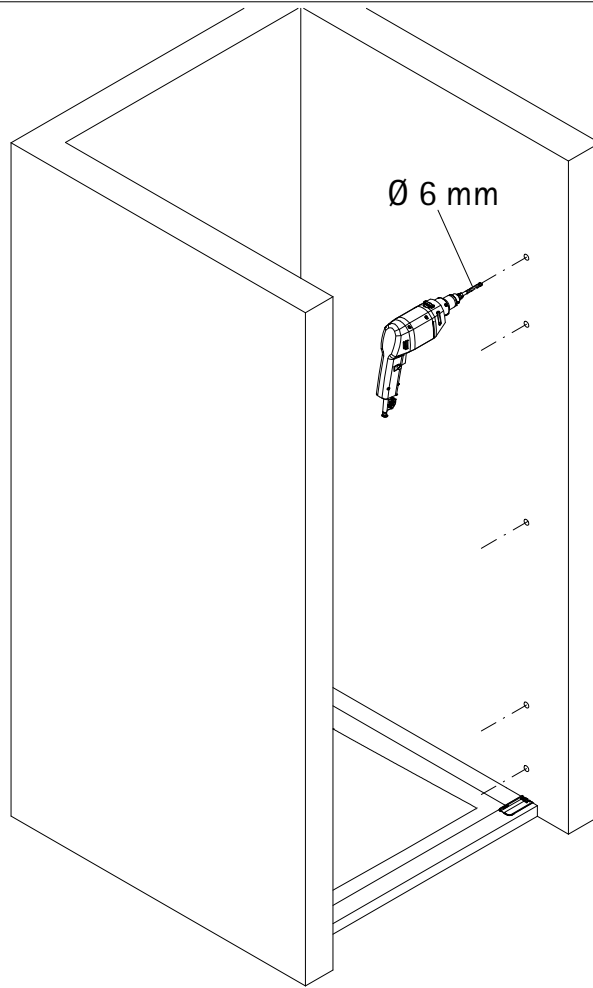

9a

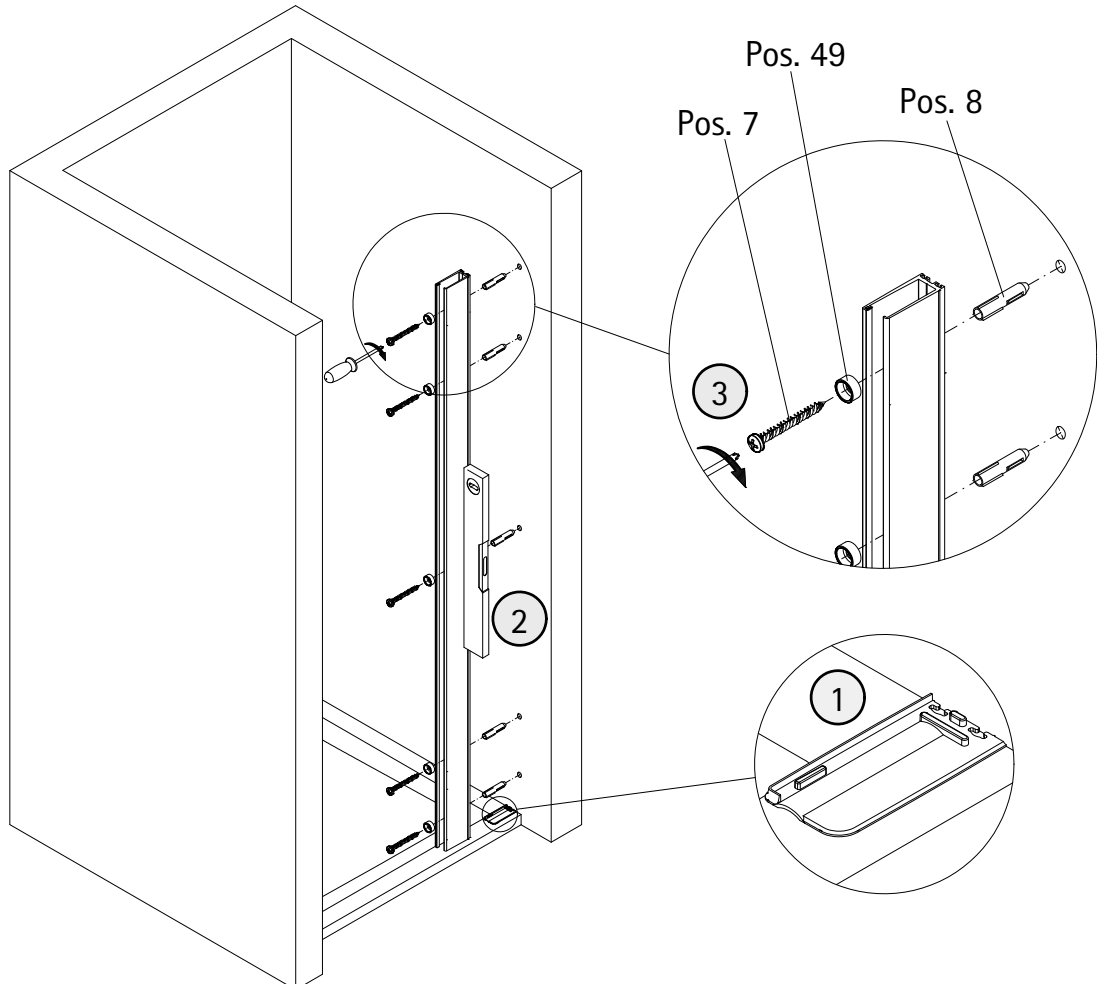

10a

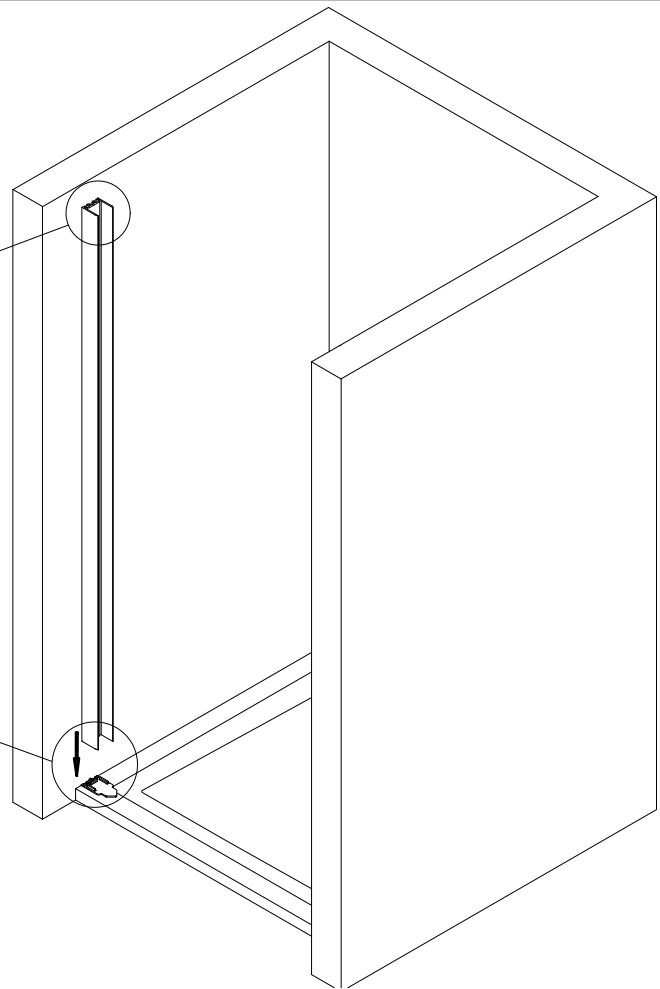
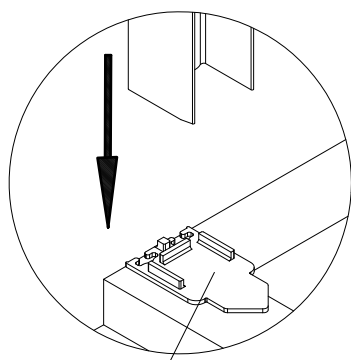
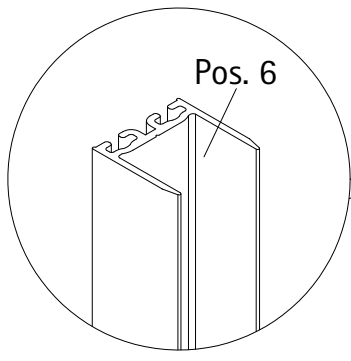

11a

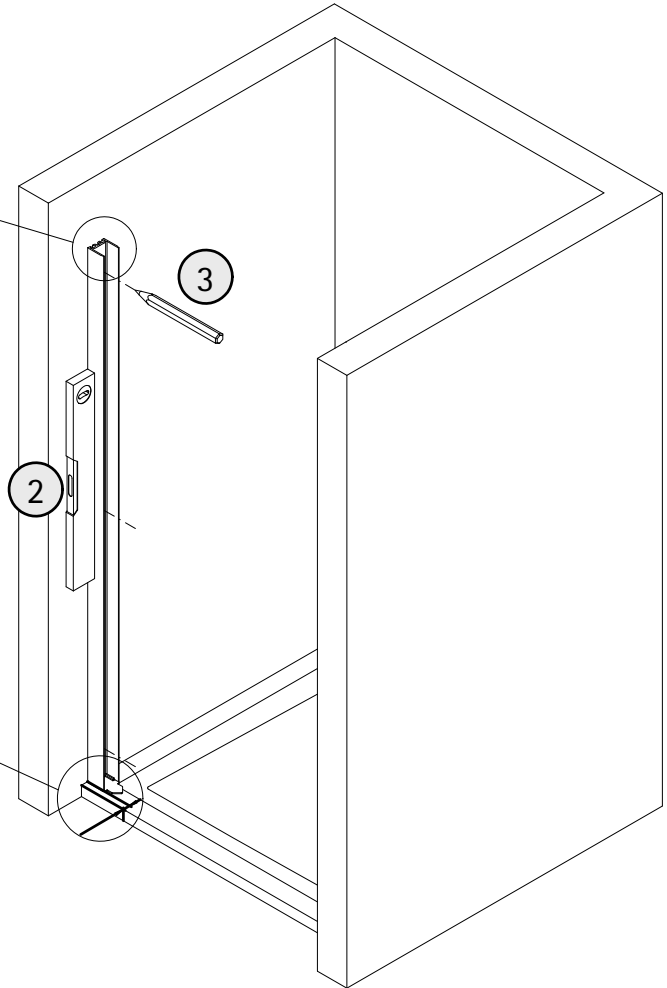
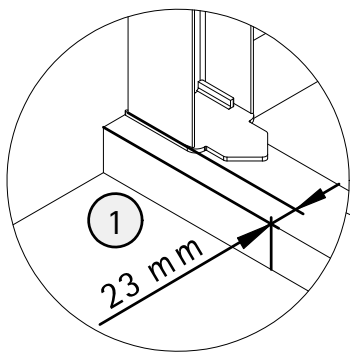
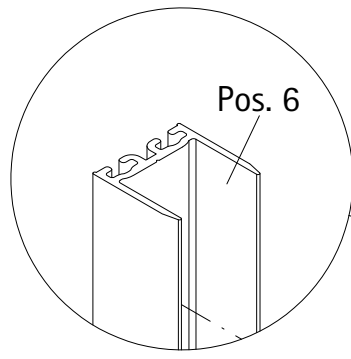

12a

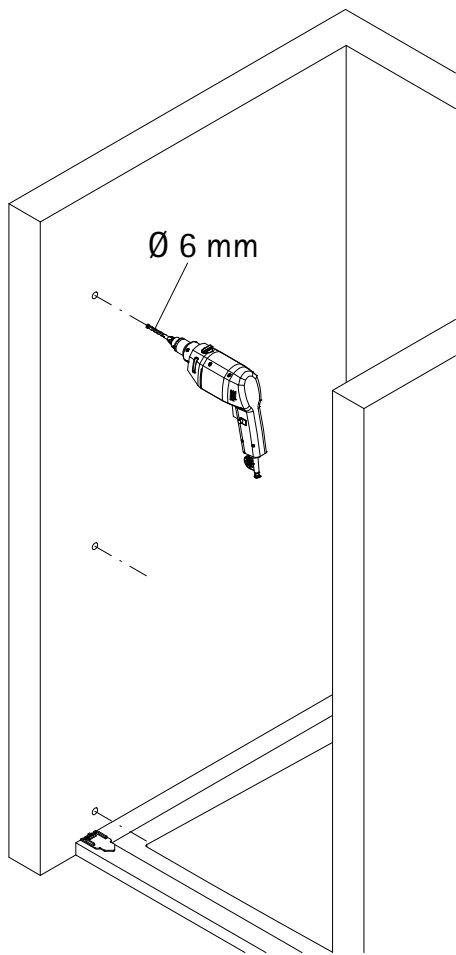

13a

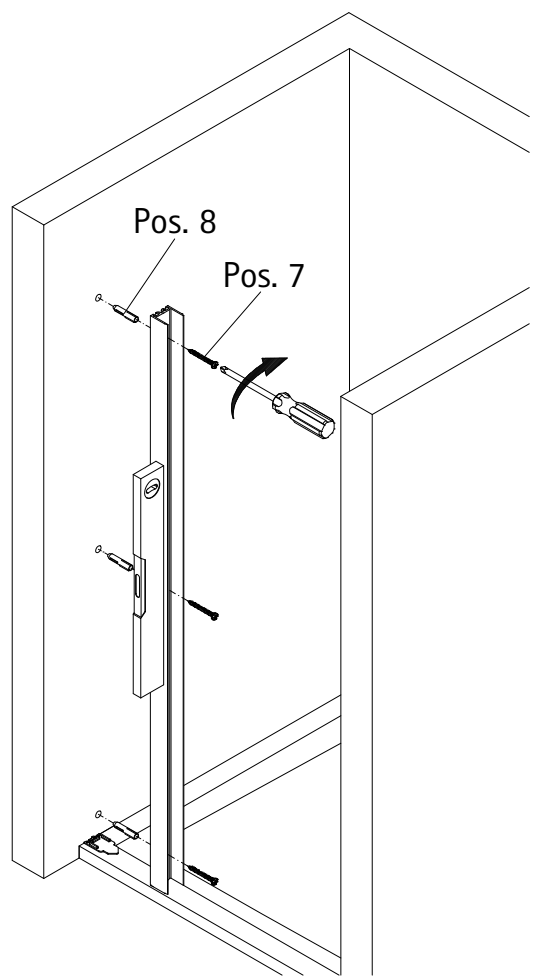

6b

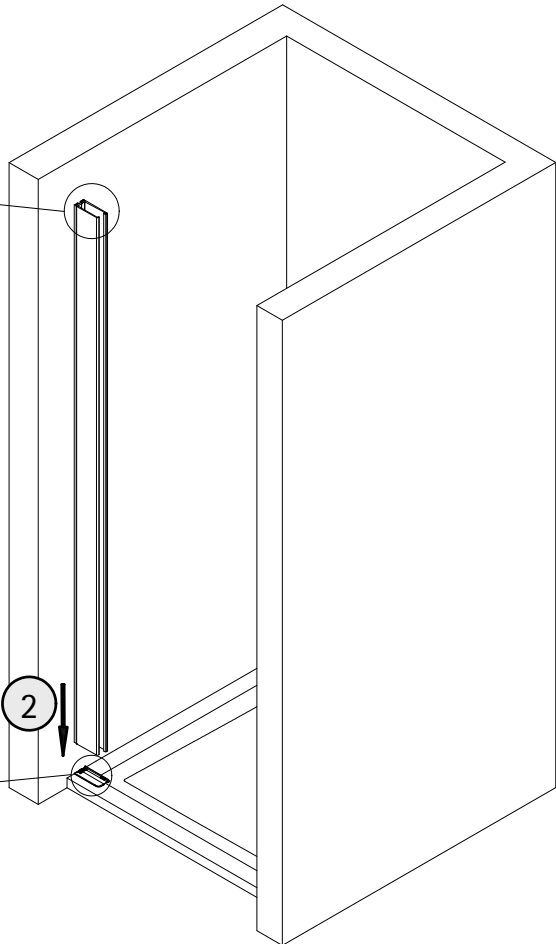
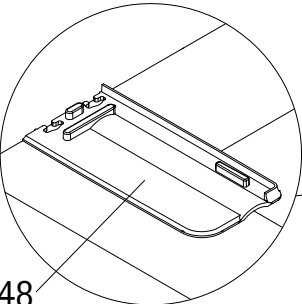
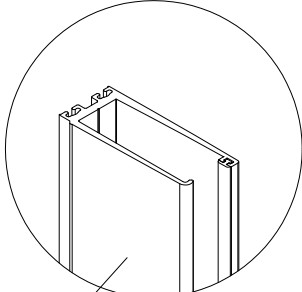
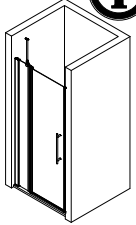

7b

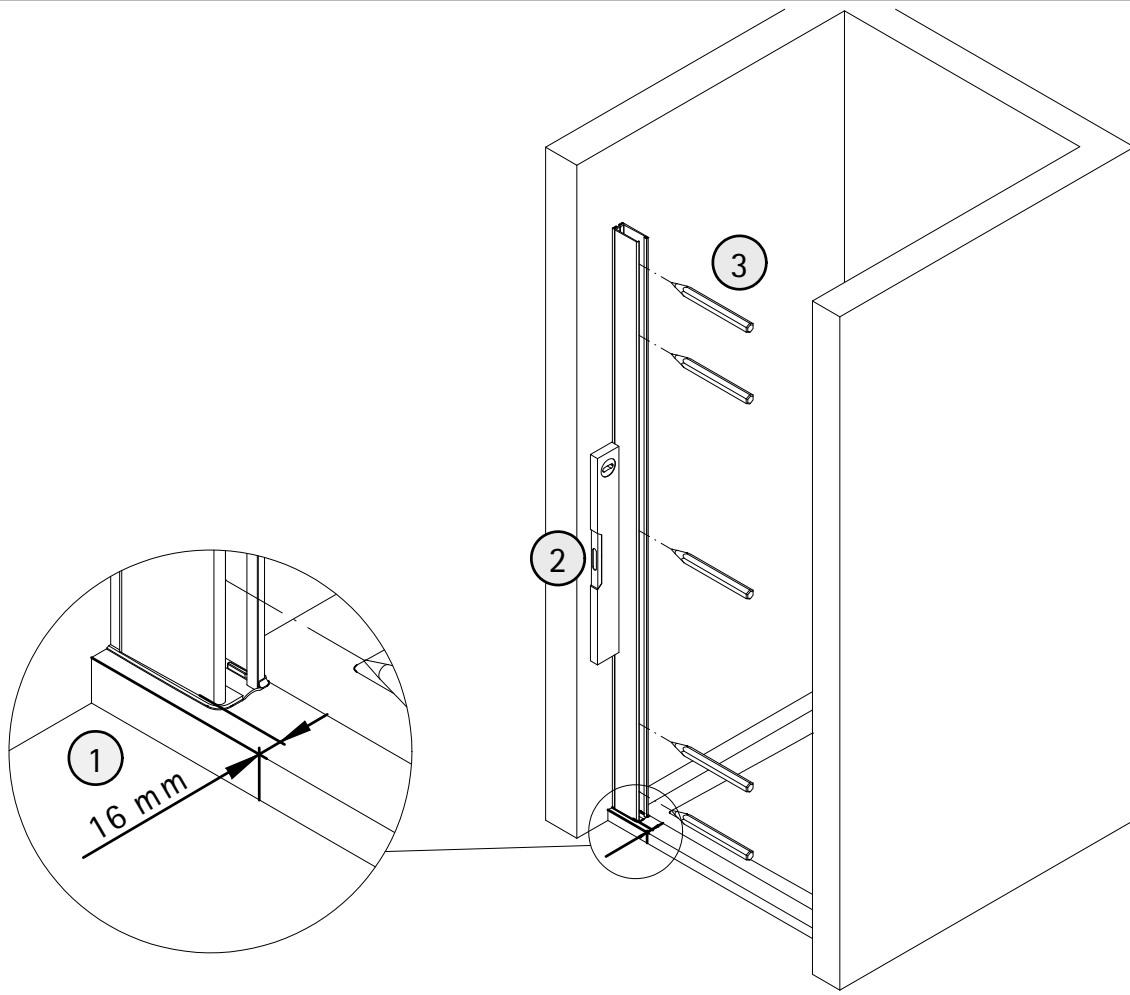

8b

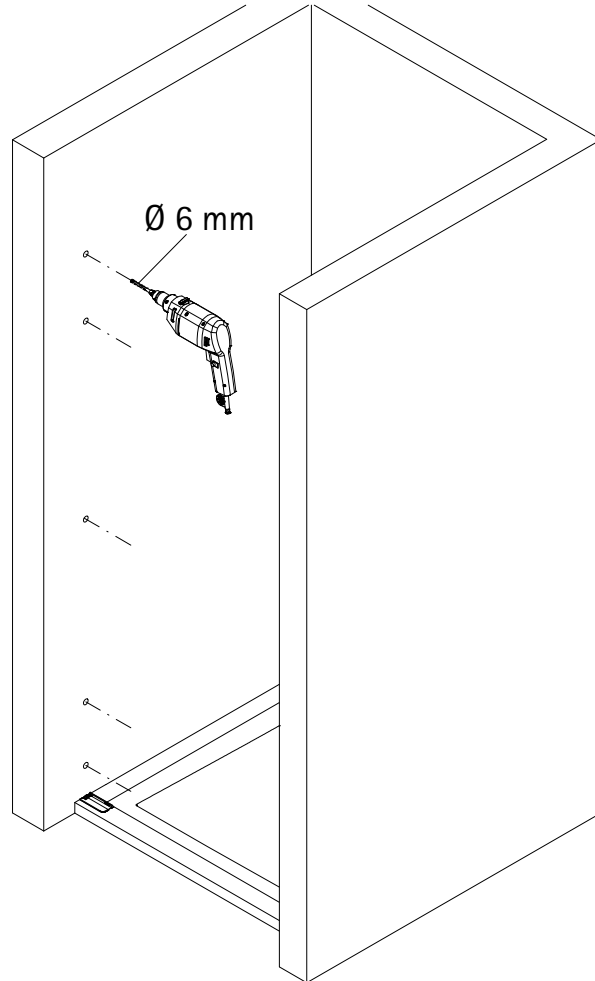

9b

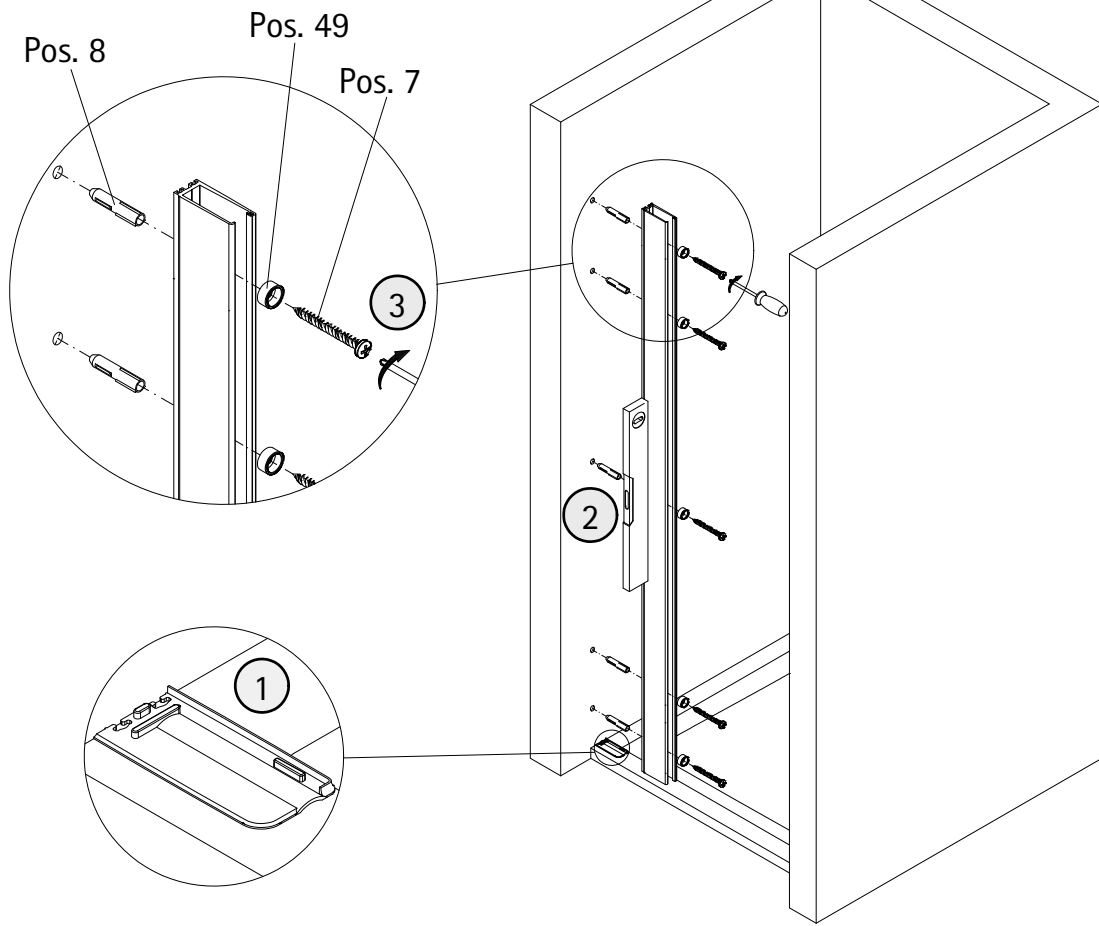

10b

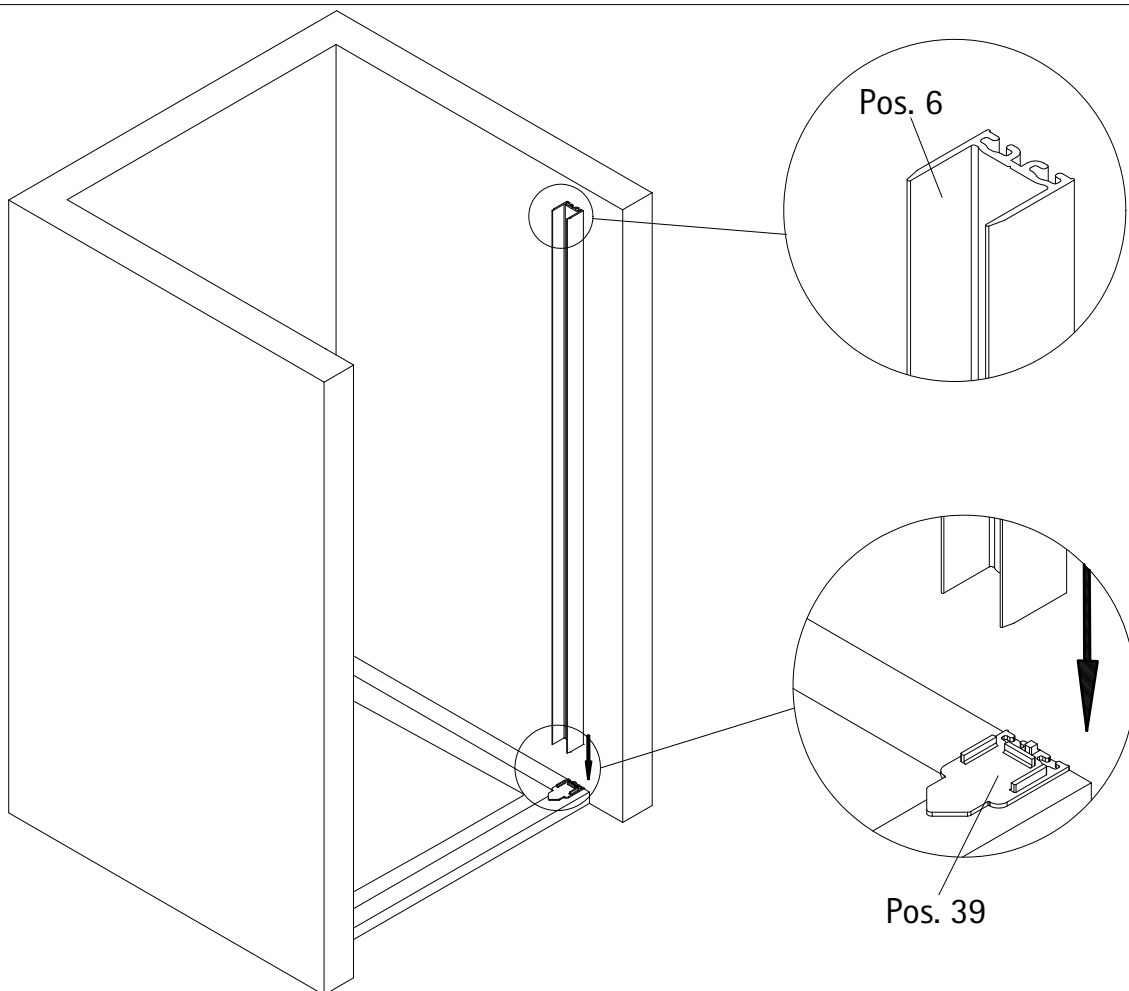

11b

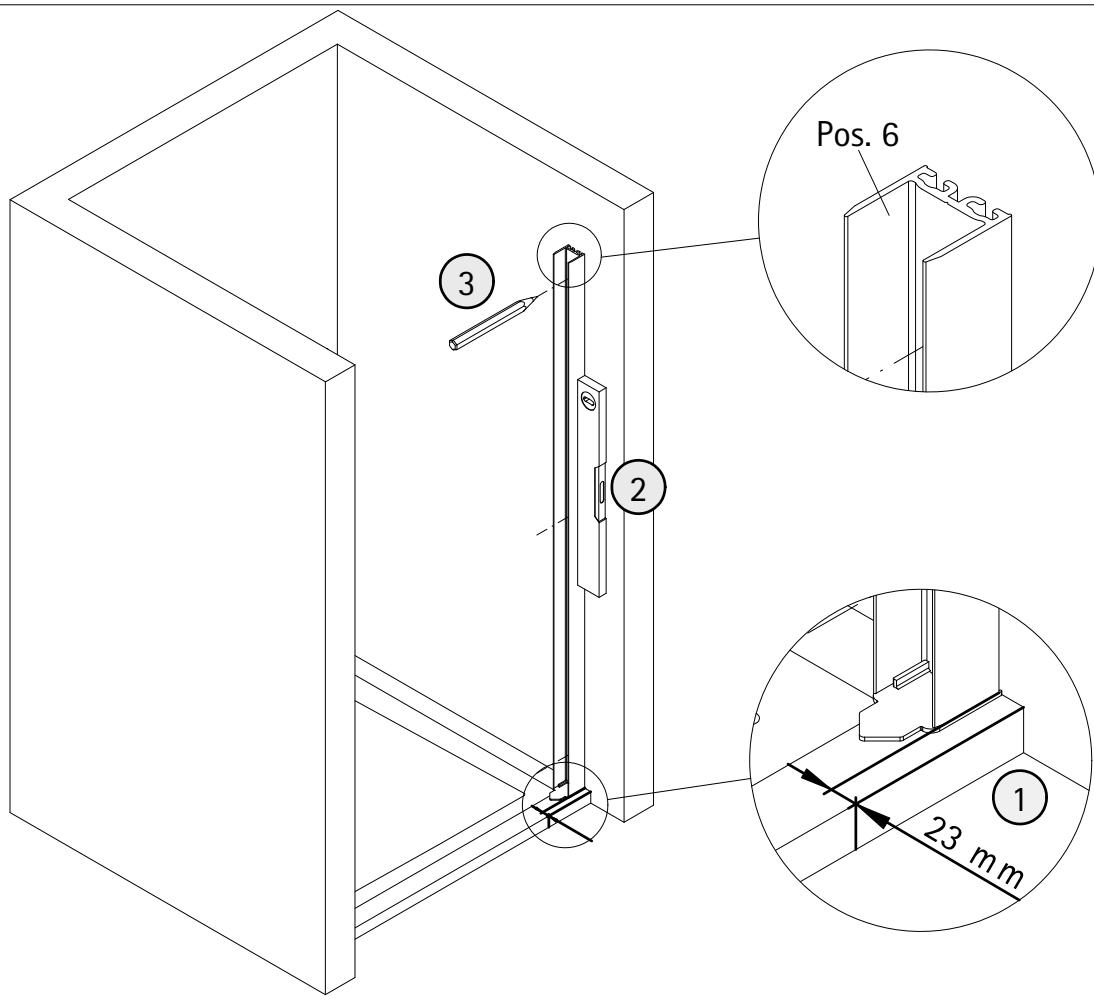

12b

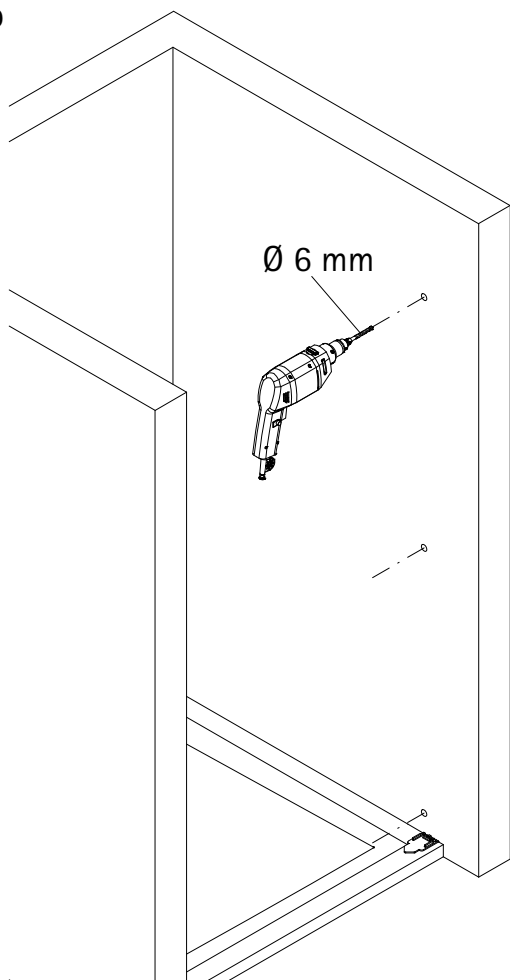

13b

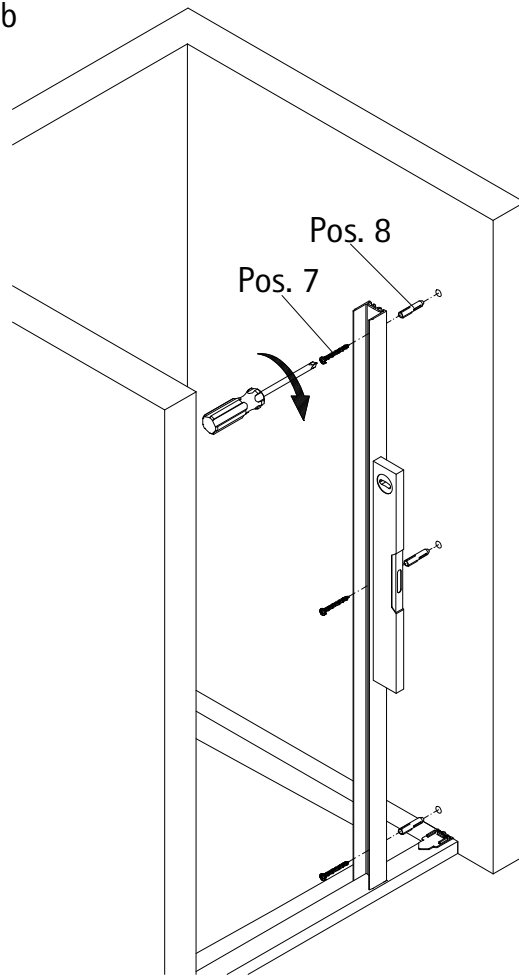

14

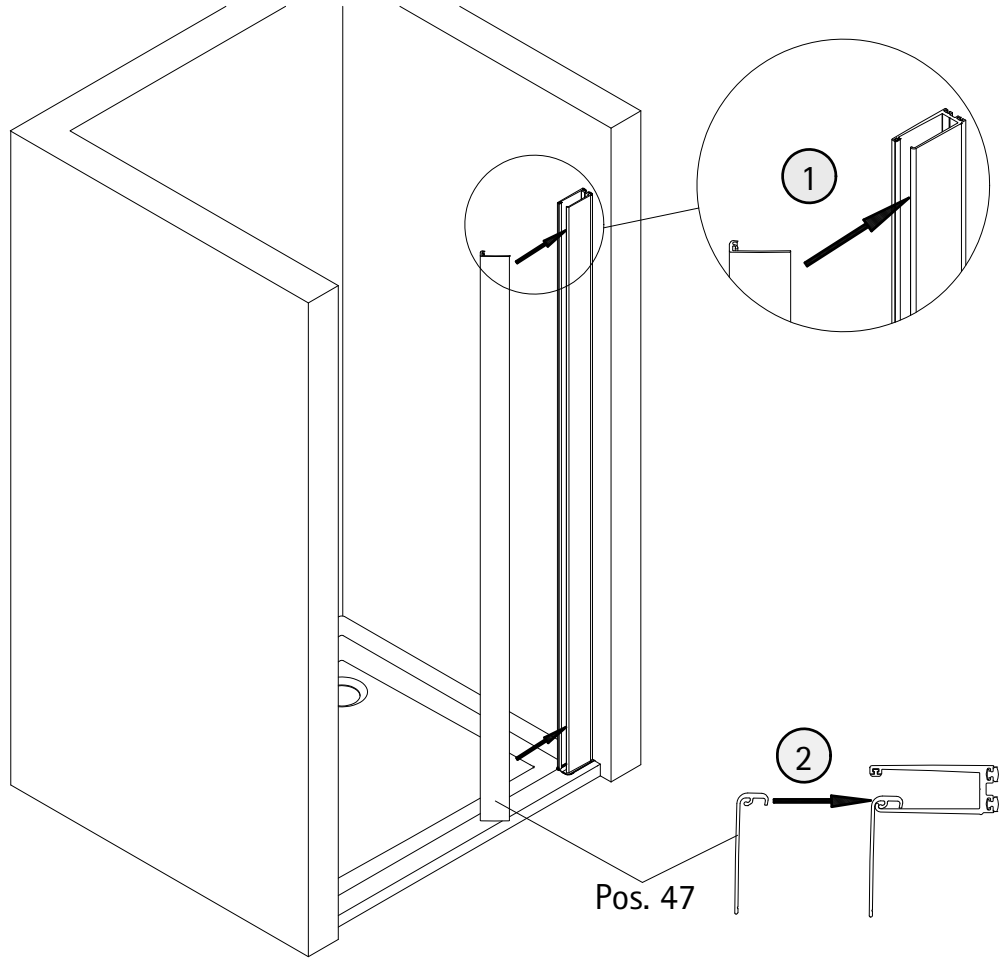
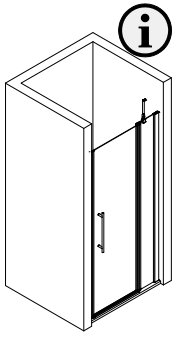

15

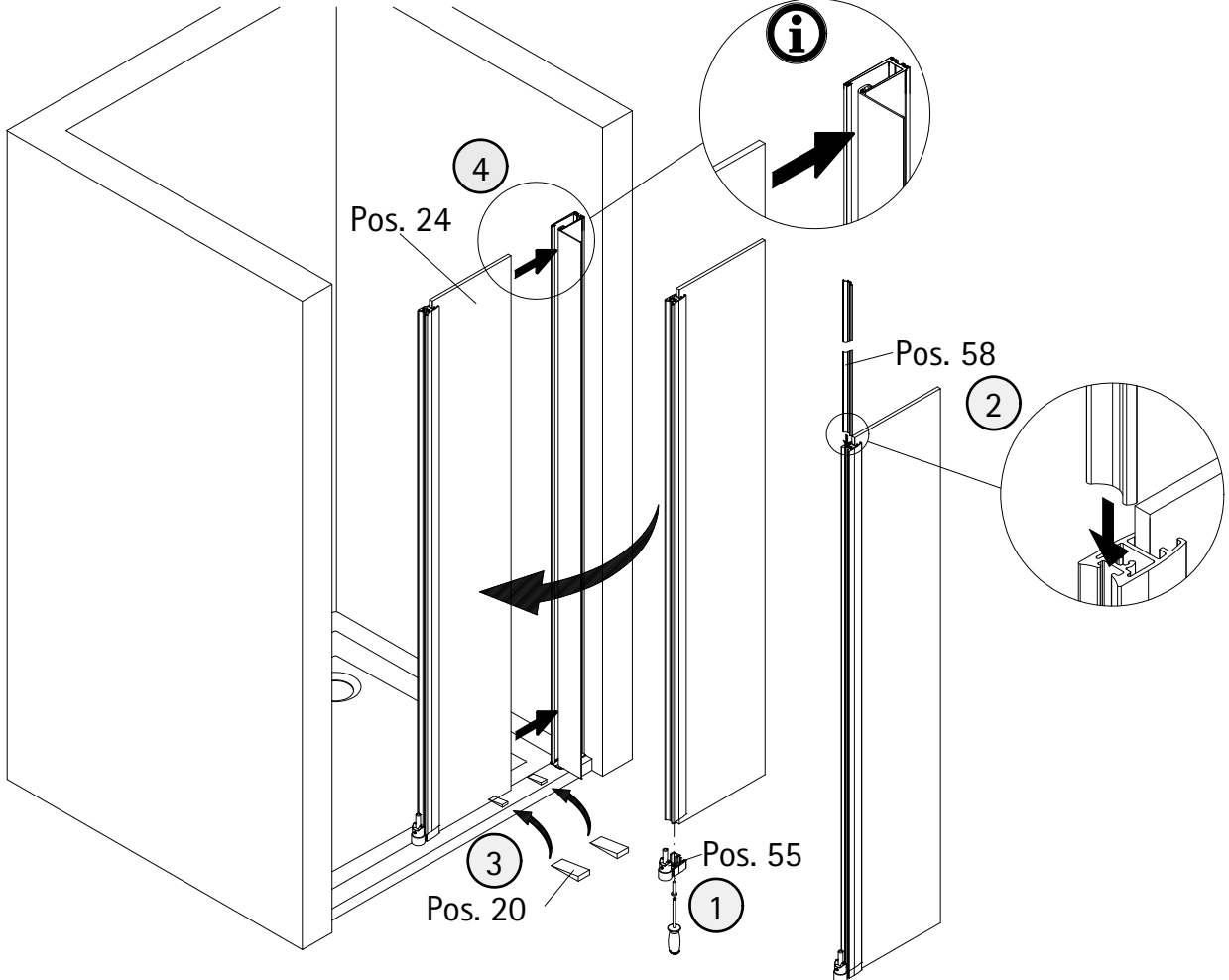

16

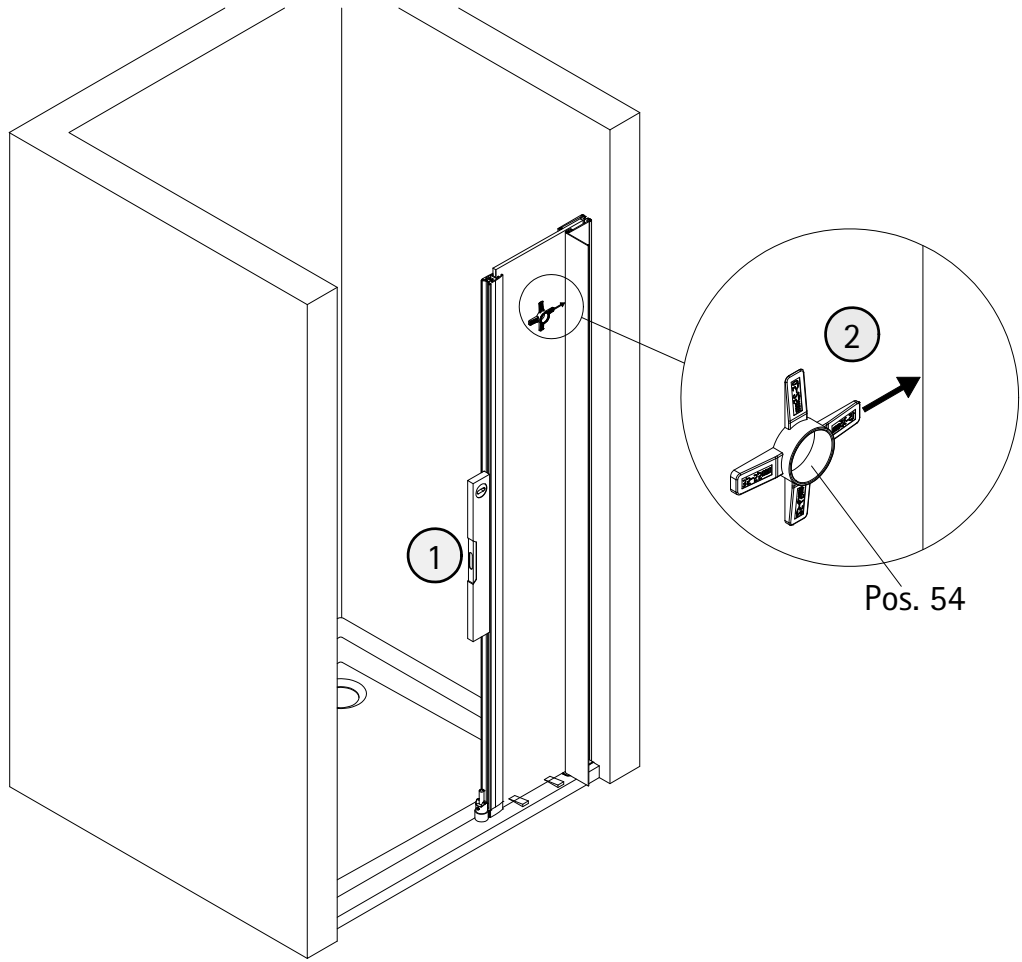

17

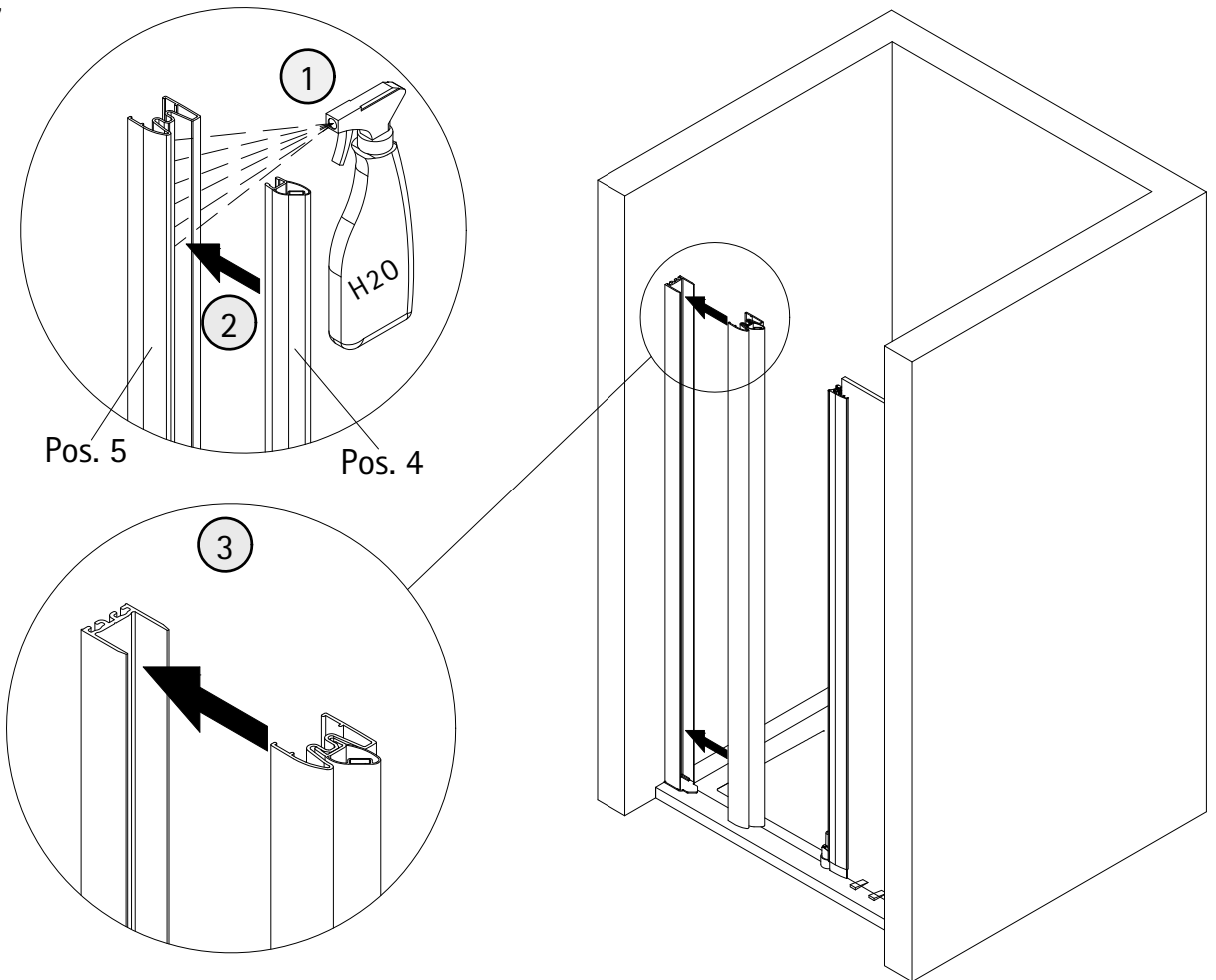

18

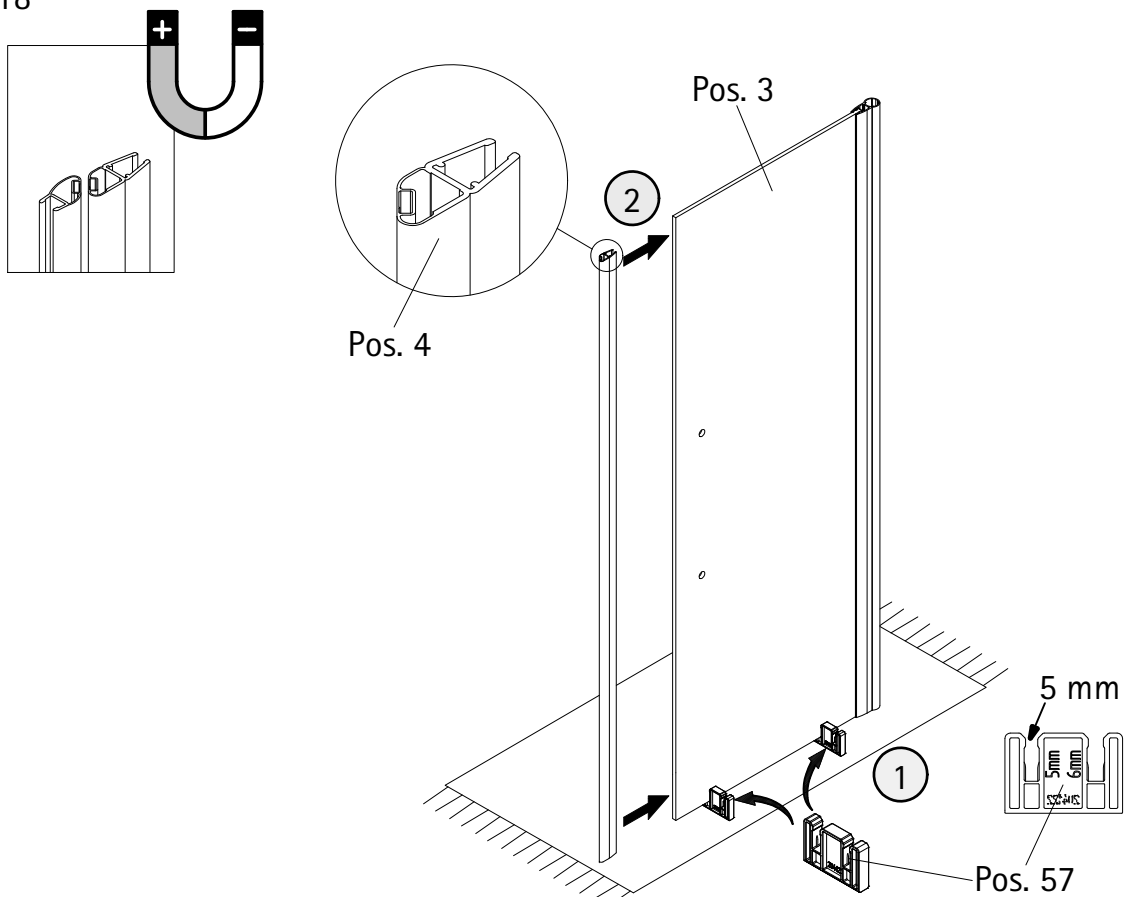

19

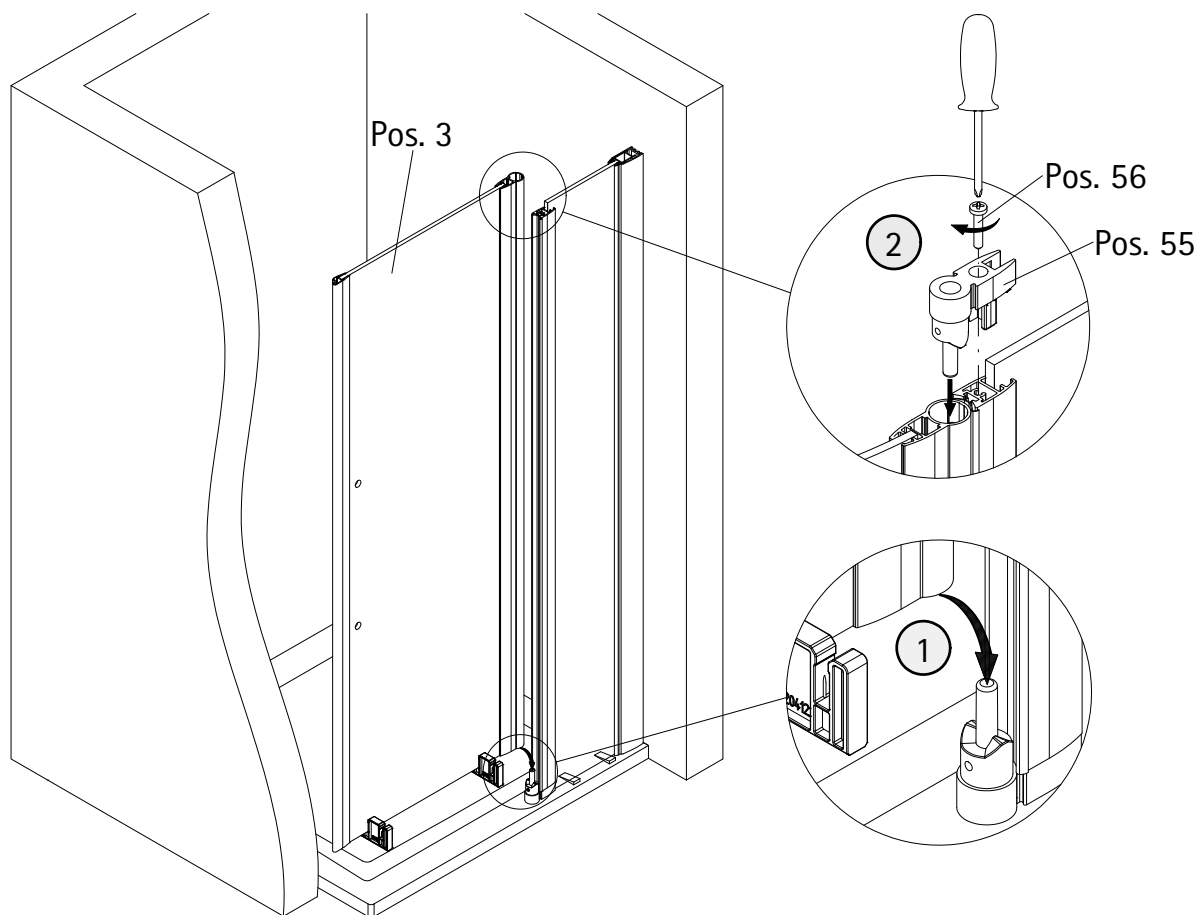

20

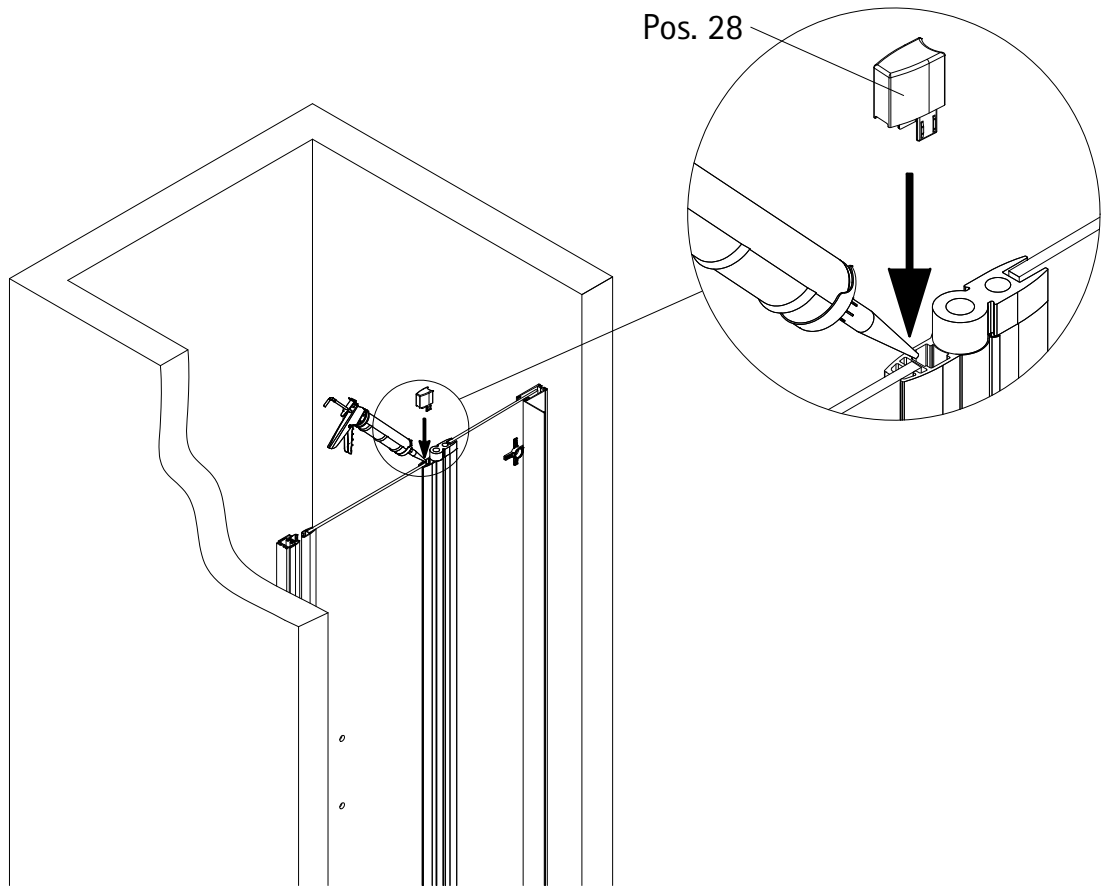

21

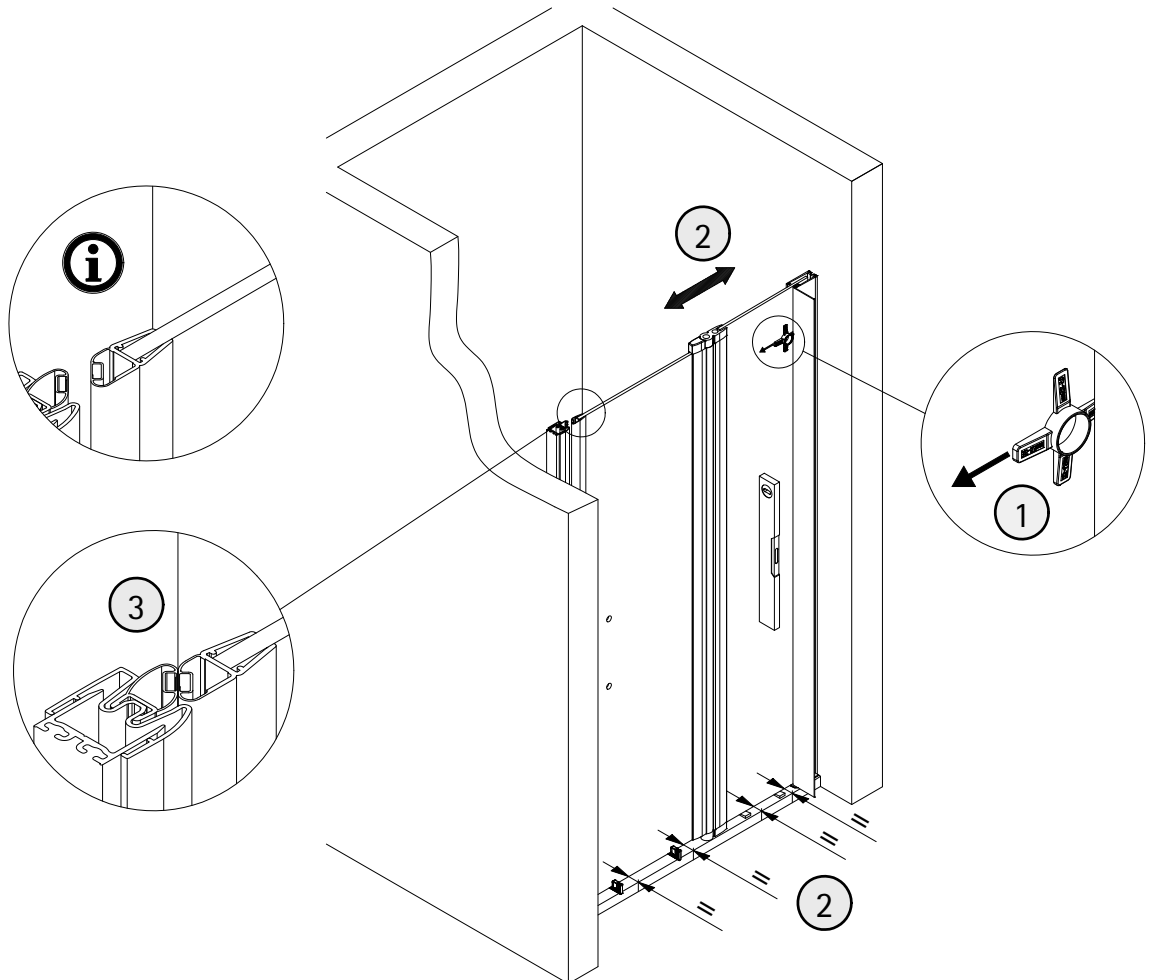

22

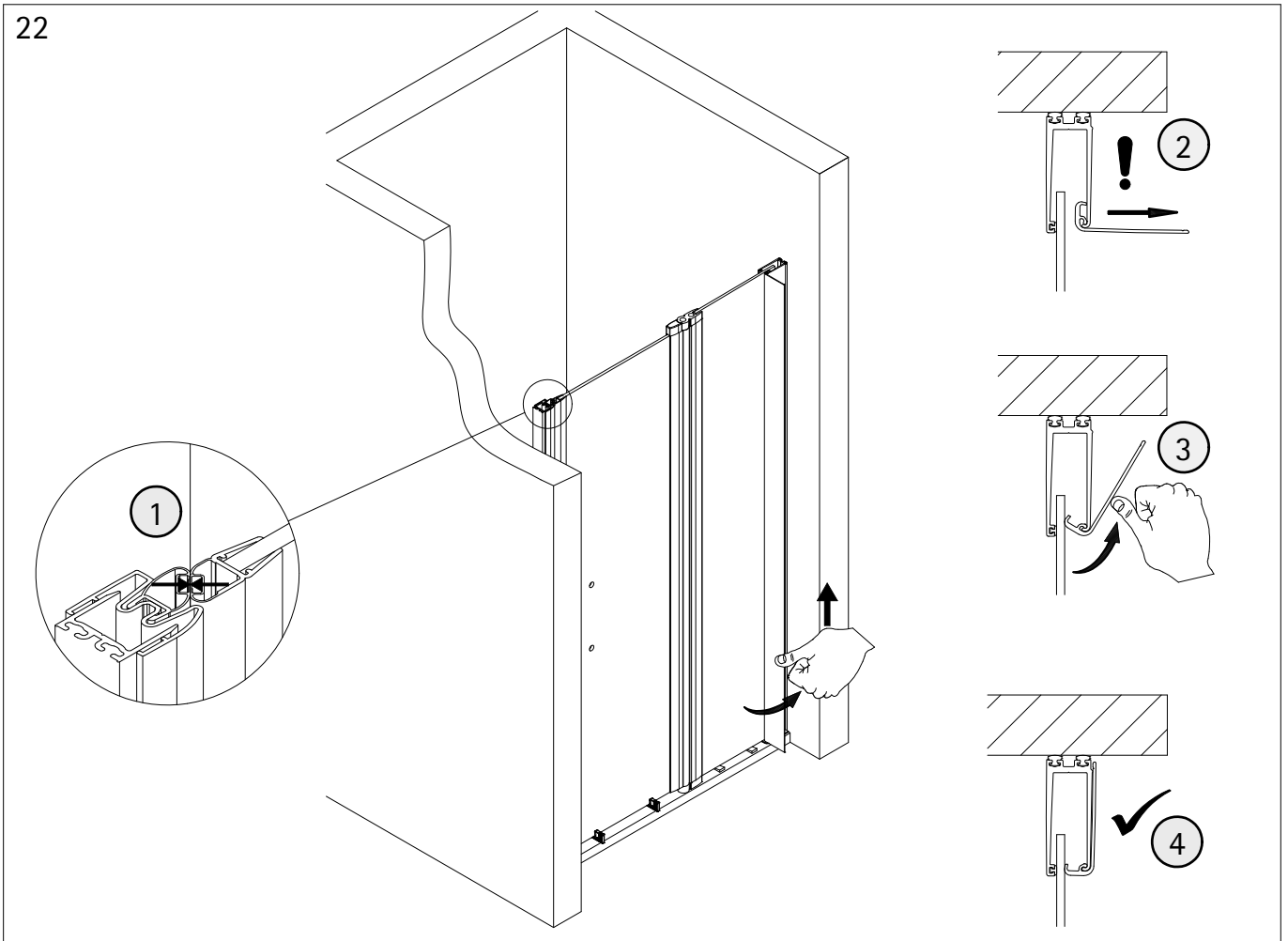

23

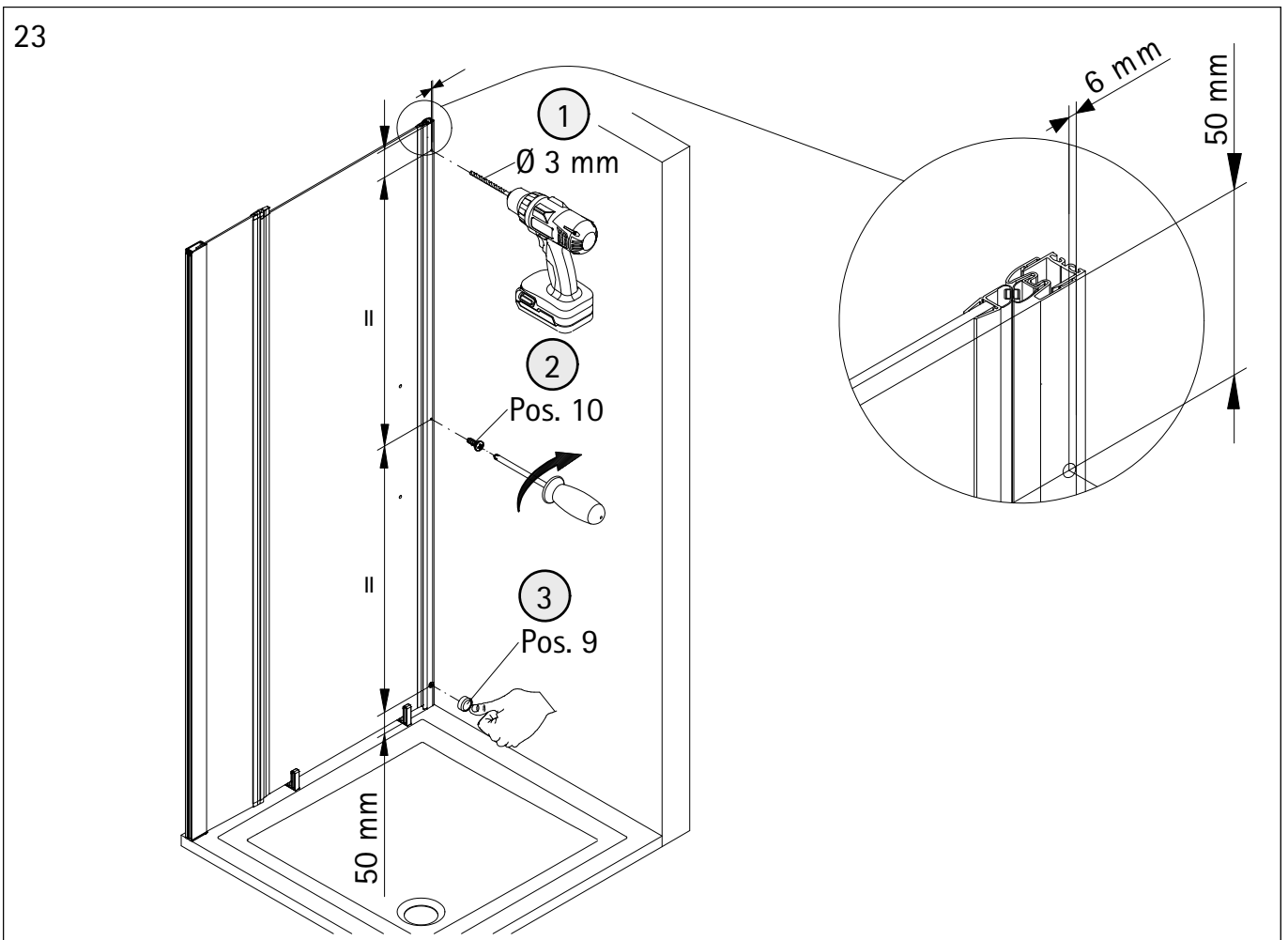

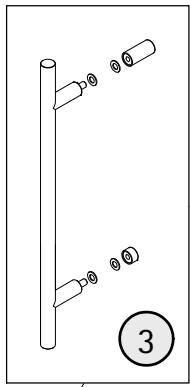

Pos. 16

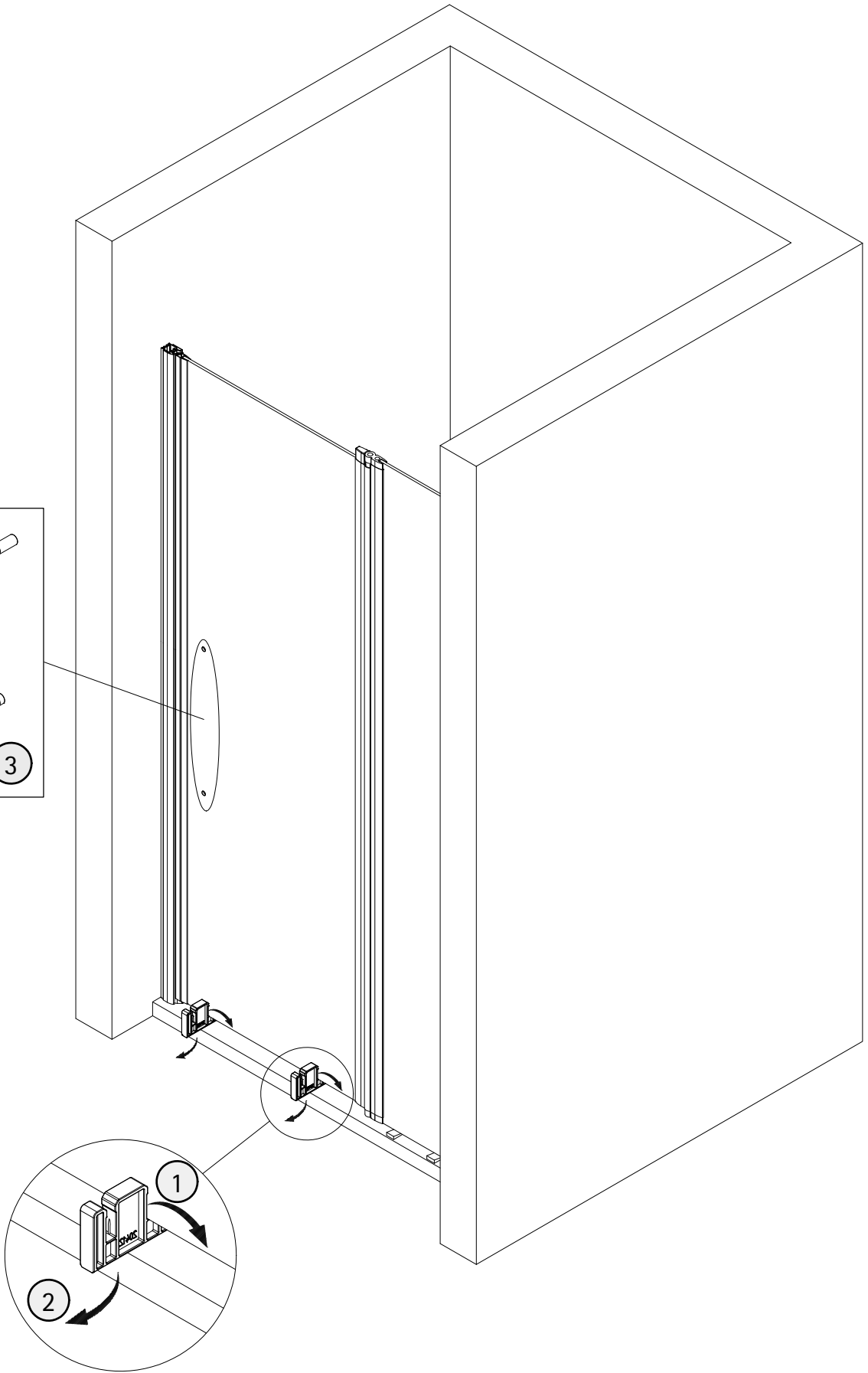

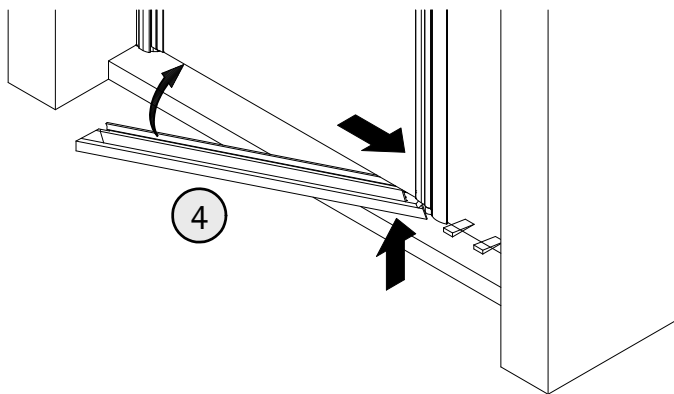
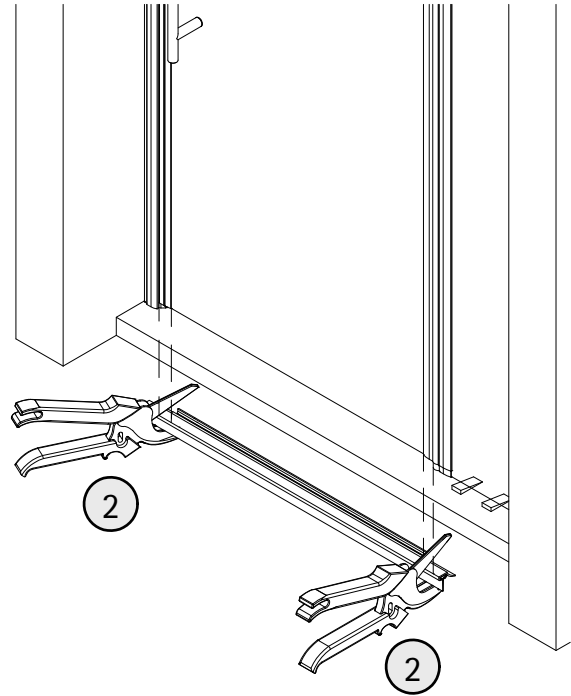
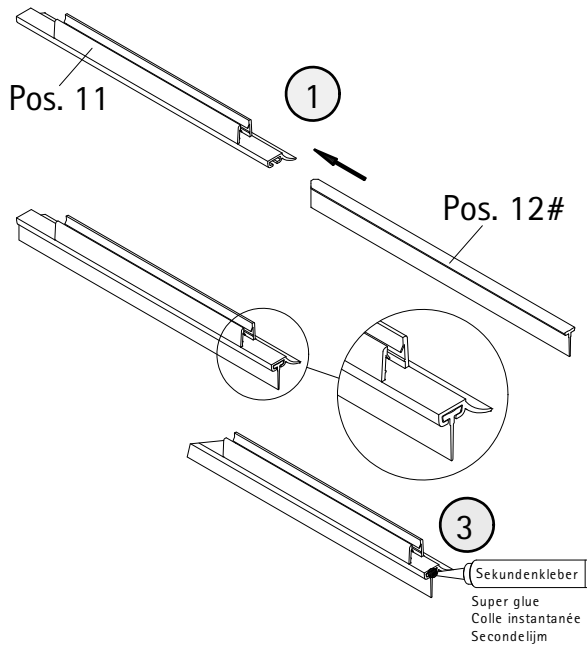
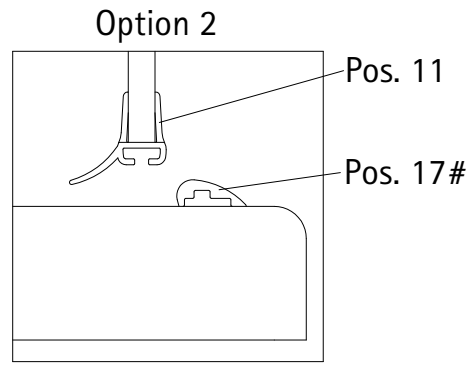
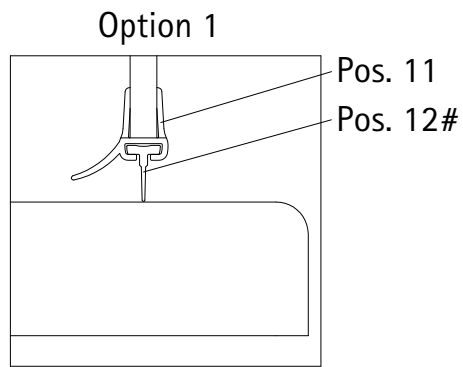

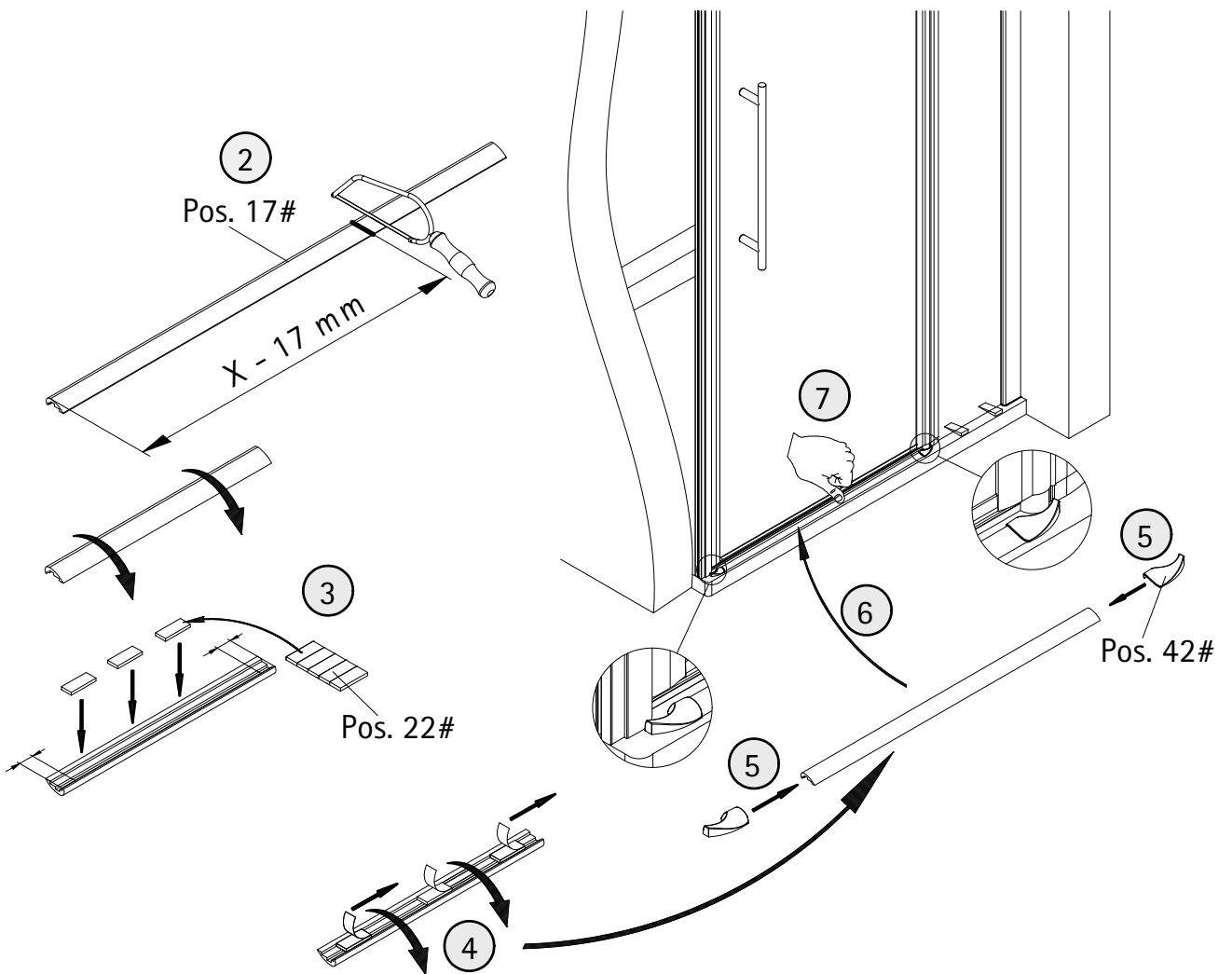
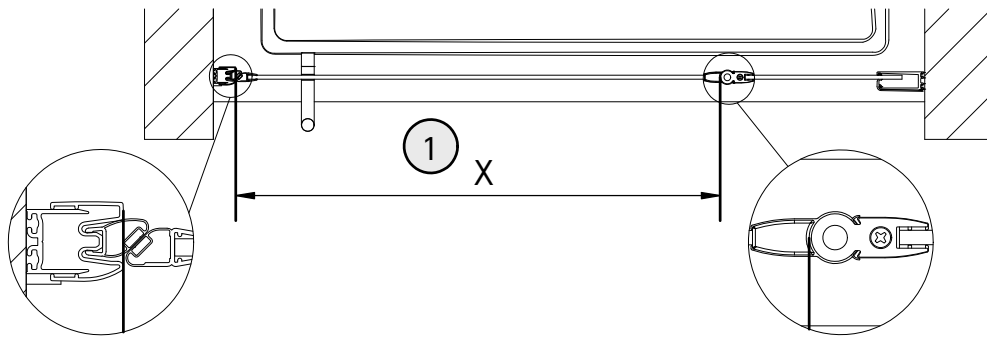

27

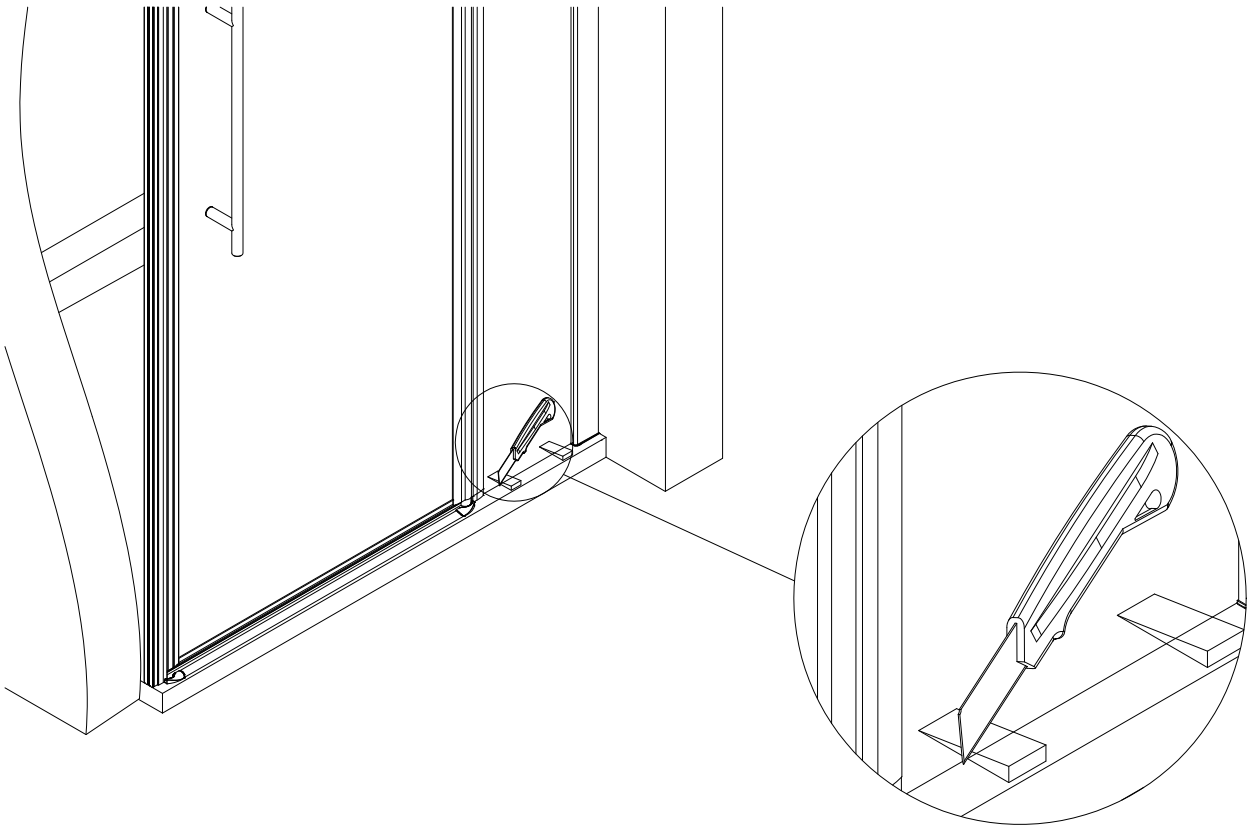

28

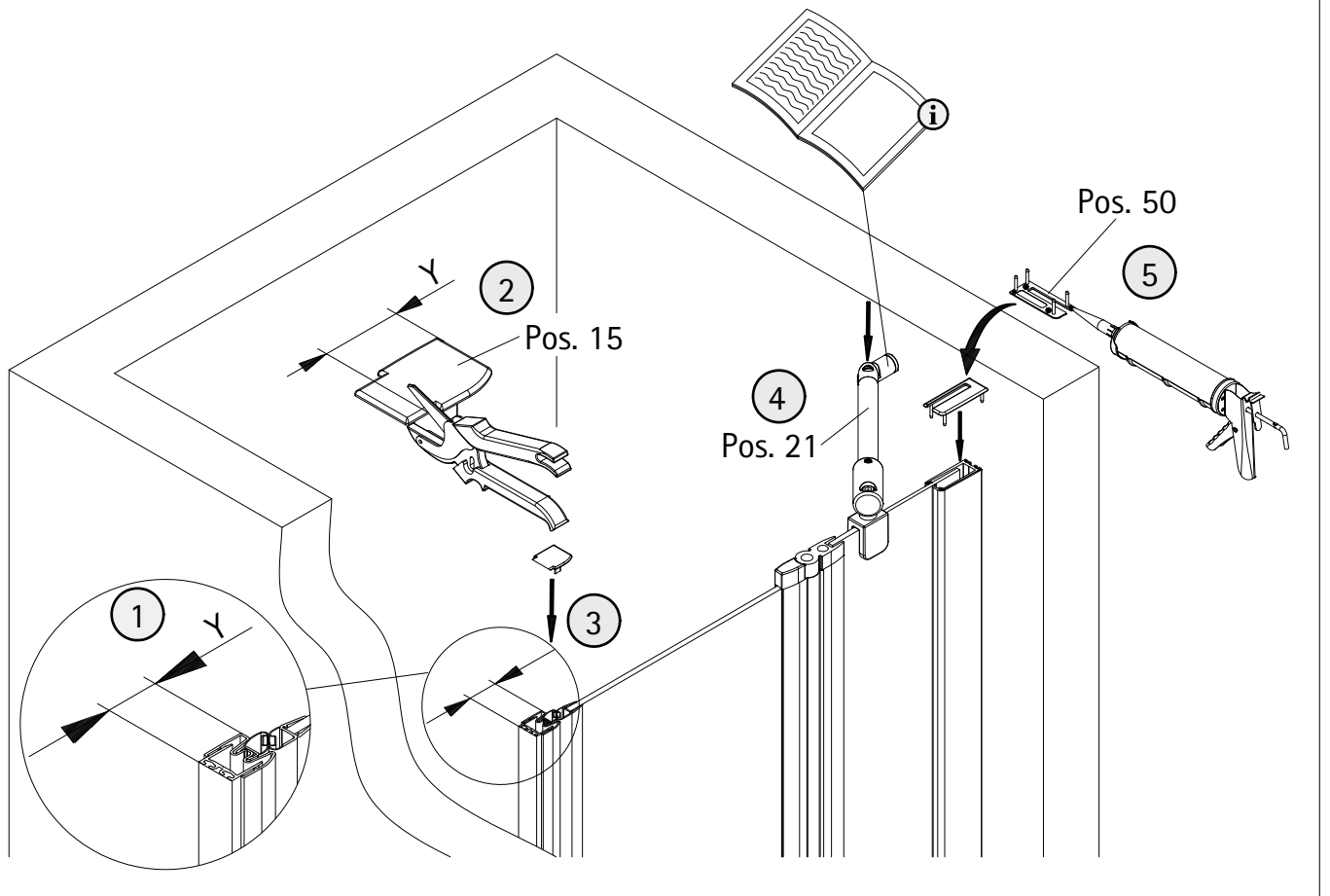

29

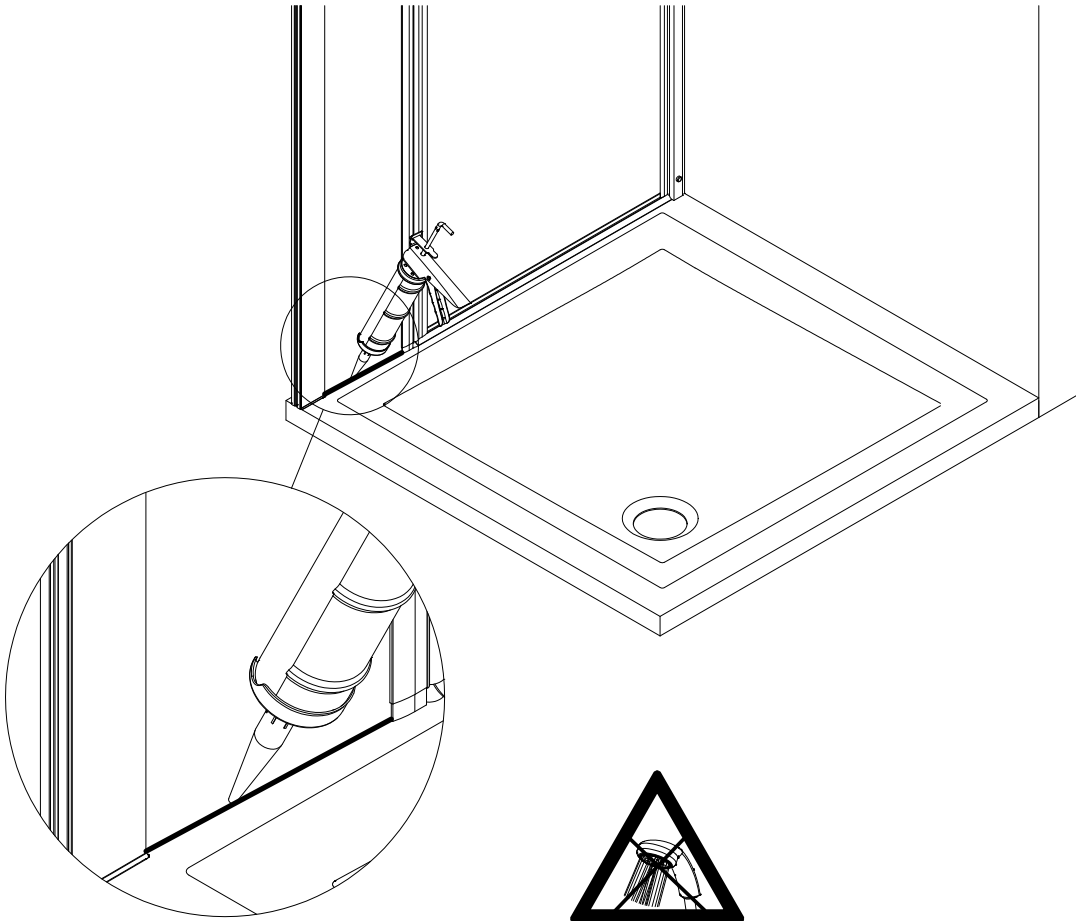

30

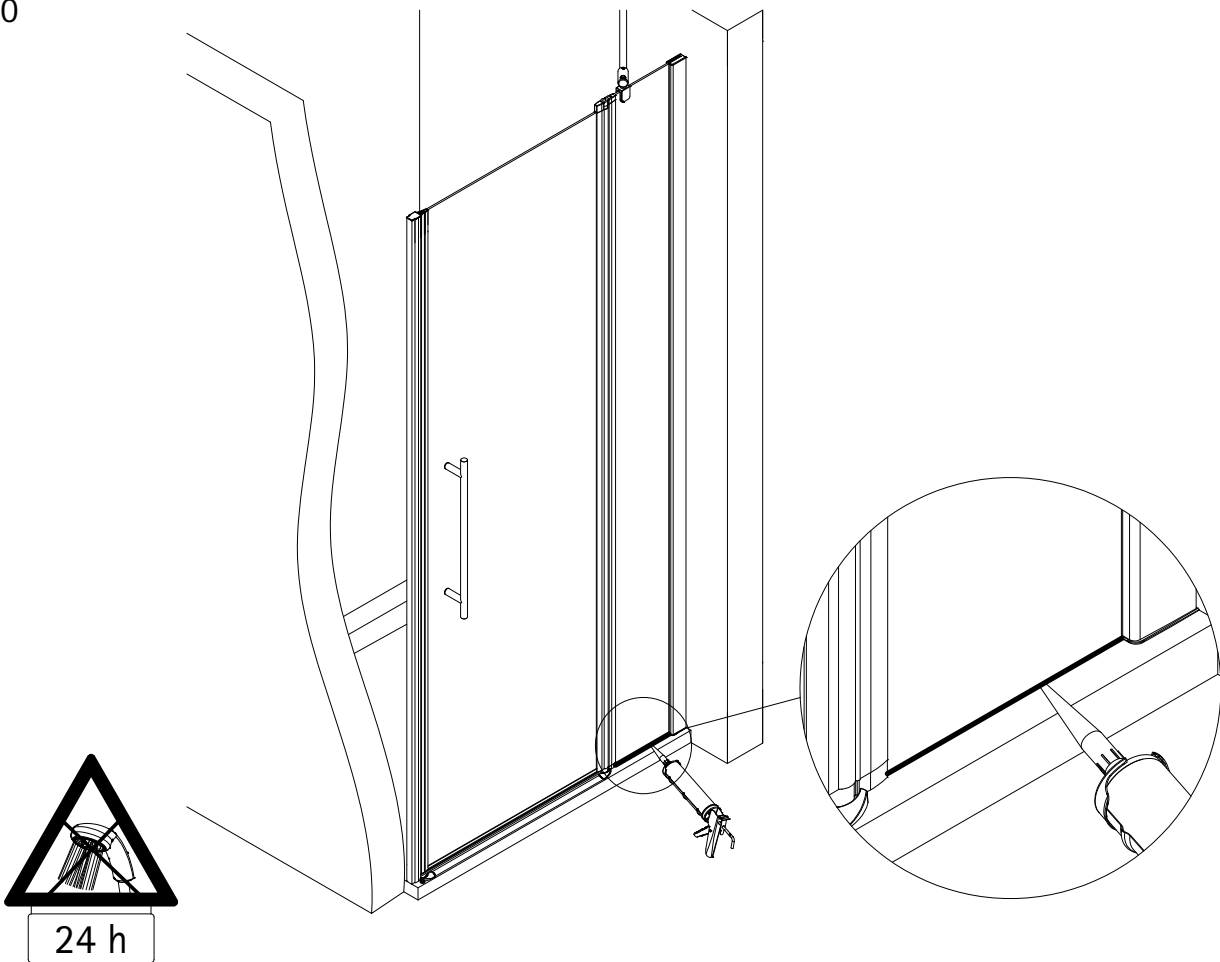

31

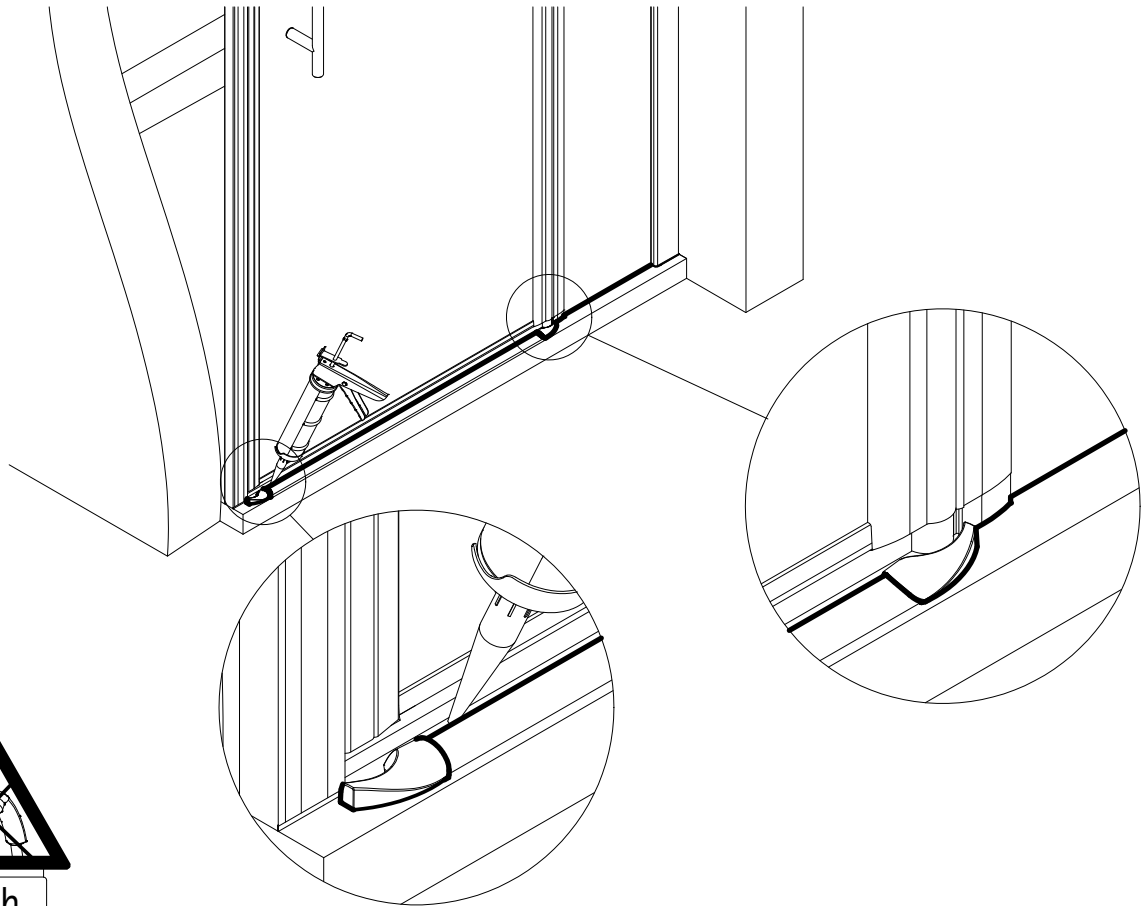

Hinweis Demontage/ Note for disassembly/ Remarque sur le démontage/ Informatie demontage

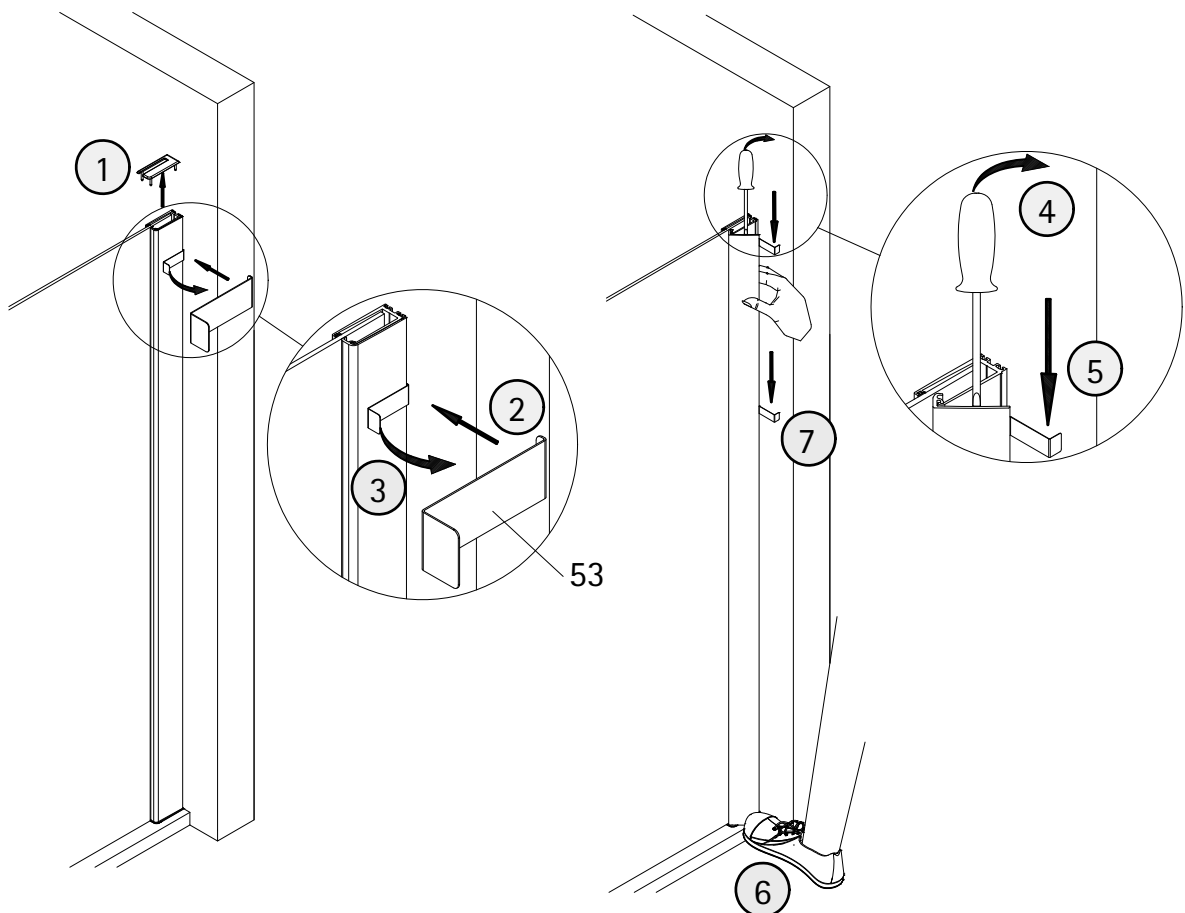

2006-1

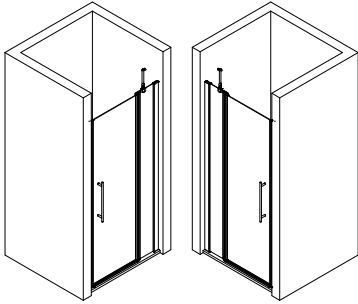

Kontrollbeleg
Control Receipt

Prüfnummer/ Inspection number



Duschservice
Zum Hohlen Morgen 22
59939 Olsberg
Deutschland / Germany / Allemagne / Duitsland



Ersatzteilbestellung:
Fax 02962 / 972-4260



Allgemeine technische Probleme:
Telefon 02962 / 972-40



E-Mail:
ersatzteile@duschservice.de