

MMA- 120/140/160

User Manual
Original Instruction



For Your Safety

Read and understand this manual before use. Keep this manual for future reference.

HYUNDAI

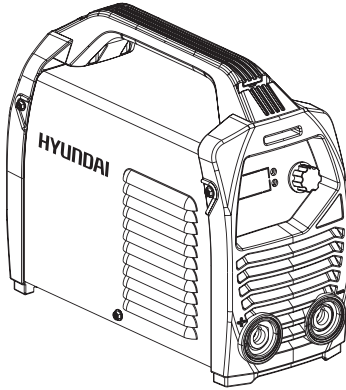
MMA-120/140/160

We are still constantly improving this welder, therefore, some parts of this welder may be changed in order to achieve the better quality, but the main functions and operations will not be alternated and changed.

Your understanding would be greatly appreciated.

Table of Contents

Safety	3
General Description	5
Main Parameters	6
Electric Block Diagram	7
Operation Control and Description	8
Installation Debugging and Operation	9
Caution	10
Maintenance	11
Troubleshooting	12
Exploded Drawing	13

1. Safety

Welding is dangerous, and may cause damage to you and others, so take good protection when welding. For details, please refer to the operator safety guidelines in conformity with the accident prevention requirements of the manufacturer.



Professional training is needed before operating the machine.

- Use labor protection welding supplies authorized by national security supervision department.
- The operator must be qualified personnel with a valid “metal welding (OFC) operations” operation certificate.
- Cut off power before maintenance or repair.

Electric shock—may lead to serious injury or even death.

- Install earth device according to the application criteria.
- Never touch the live parts when skin bore or wearing wet gloves/clothes.
- Make sure that you are insulated from the ground and work piece.
- Make sure that your working position is safe.

Smoke& gas—may be harmful to health.

- Keep the head away from smoke and gas to avoid inhalation of exhaust gas from welding.
- Keep the working environment in good ventilation with exhaust or ventilation equipment when welding.

Arc radiation—may damage eyes or burn skin.

- Wear suitable welding masks and protective clothing to protect your eyes and body.
- Use suitable masks or screens to protect spectators from harm.

Improper operation may cause fire or explosion.

- Welding sparks may result in a fire, so please make sure no combustible materials nearby and pay attention to fire hazard.
- Have a fire extinguisher nearby, and have a trained person to use it.
- Airtight container welding is forbidden
- Must not use the machines for other purposes except welding, such as pipe thawing, battery charging, heating.



Hot work piece may cause severe scalding.

- Do not contact hot work piece with bare hands.
- Cooling is needed during continuous use of the welding torch.

Magnetic fields affect cardiac pacemaker.

- Pacemaker users should be away from the welding spot before medical consultation.

Moving parts may lead to personal injury.

- Keep yourself away from moving parts such as fan.
- All doors, panels, covers and other protective devices should be closed during operation.

Please seek professional help when encountering machine failure.

- Consult the relevant contents of this manual if you encounter any difficulties in installation and operation.
- Contact the service center of your supplier to seek professional help if you still cannot fully understand after reading the manual or still cannot solve the problem according to the manual.

2. General Description

Advanced DC inverter technology

- High inverter frequency greatly reduces the volume and weight of the welder.
- Great reduction in magnetic and resistance loss obviously enhances the welding efficiency and energy saving effect.
- Switching frequency is beyond audio range, which almost eliminates noise pollution.

Leading control mode

- Advanced control technology meets various welding applications and greatly improves the welding performance.
- It can be widely used in acid and basic electrode welding.
- Easy arc starting, less spatter, stable current and good shaping.

Features of MMA series

- Efficiency, energy saving, portable, stable arc, high no-load voltage, and with good compensation of arc force, are able to meet various welding requirements in field work.

3. Main Parameters

Technical parameters table:

Model	MMA-120	MMA-140	MMA-160
Rated Input Voltage (V)	1P AC 230V, 50Hz		
Rated Input Power (KVA)	4.8	5.8	6.8
Rated Input Current (A)	20.8	25	29.6
Rated Output Current & Voltage	120A/24.8V	140A/25.6V	160A/26.4V
Output Current (A)	20-120	20-140	20-160
No-load Voltage (V)	67±5		
Rated Duty Cycle (%)	30	30	25
Efficiency (%)	85		
Power Factor (cose)	0.73		
Protection Class	IP21S		
Insulation Class	F		

4. Electric Block Diagram

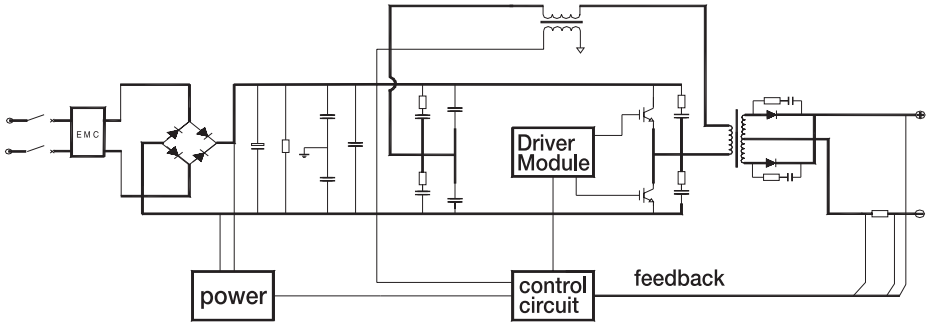

5. Operation Control and Description

• Front panel

- 1) Current display meter
- 2) **Power LED** : Power LED “on” indicates the power switch of machine is on.
- 3) **Overheating LED** : Overheating LED “on” indicates the temperature inside machine is too high.
- 4) **Output power control switch** : To adjust the output power
- 5) **“+” output terminal** : To connect with electrode holder
- 6) **“-” output terminal** : To connect with earth clamp

* The connection as mentioned above in (5) and (6) is DCEP(Straight polarity) connection. Operator can choose DCEN(Reverse polarity) connection when using alkaline electrode. Generally, Both methods can be applied for acid electrode.

• Back panel

- 7) Fan
- 8) Power switch : Power on/off
- 9) Power input : Power input cable

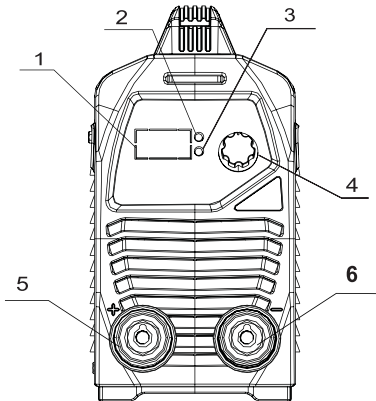

Front Panel

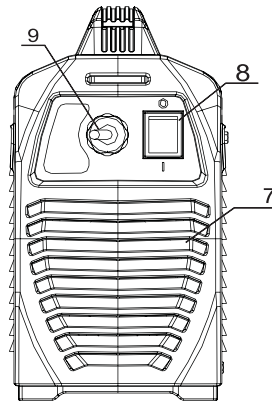

Back Panel

6. Installation Debugging and Operation

Warning

Please install the machine strictly according to the following steps.

The protection class of this machine is IP21S, so avoid using it in rain.

Before using, please make sure the input voltage is in voltage range (200V-240V). Otherwise, the machine will be damaged.

- The electrode holder and earth clamp are easily connected to the machine by inserting the quick connector and rotating it clockwise. Always ensure a correct connection and pay attention to the connection polarity.
- This welder has the function of DCEP(straight polarity) and DCEN(reverse polarity). DCEN means the welders electrode holder can be connected in the “-” output terminal while the earth clamp is connected to the “+” output terminal. However, we recommend you to use the DCEP. If DCEN is connected, it will cause an unstable arc, spatter, and the electrode to stick. If these symptoms occur, change the polarity.
- Turn on the machine with power switch located on the rear of the machine.
- Set output power control switch according to the type and size of electrode.

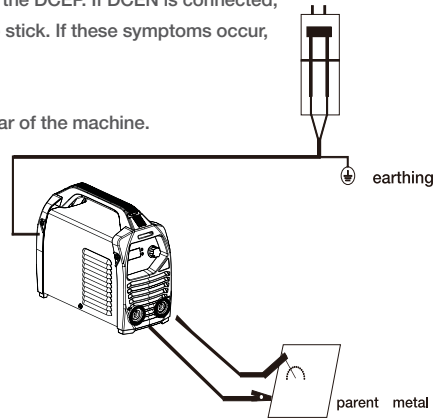

Welding parameters table (for reference only)

Electrode dia. (mm)	Recommended welding current (A)	Recommended welding voltage (V)
1.0	20-60	20.8-22.4
1.6	44-84	21.76-23.36
2.0	60-100	22.4-24.0
2.5	80-120	23.2-24.8
3.2	108-130	23.32-24.92
4.0	160-210	24.6-27.2
5.0	260-270	26.4-29.2
6.0	260-300	26.4-32.2

Remark: this table is mainly for low-carbon steel electrode.

Please consult with the supplier if operator welds other material of electrode.

7. Caution

7.1 Working environment

- 1) The product shall be operated under dry environment with normal humidity under 90%.
- 2) The temperature of working environment should be between -10°C and 40°C.
- 3) Avoid welding in the open air unless sheltered from sunlight and rain. Keep it dry anytime and do not place it on wet ground or in puddles.
- 4) Avoid welding in dusty area or environment with corrosive chemical gas.
- 5) Gas shielded arc welding should be operated in environment without strong airflow.
- 6) The welder shall be placed horizontally, on the slope of ground which does not exceed 15°.

7.2 Safety tips

Over-current/over-voltage/over-heating protection circuit is installed in this machine. If the input voltage or the output current is too high or machine inside temperature over heating inside, the machine will stop automatically. However, excessive use (e.g. too high voltage) of machine may also damage machine, so please note:

1) Ventilation

High current passes when welding is carried out, thus natural ventilation cannot satisfy the machine's cooling requirement. Maintain good ventilation through the louvers of the machine. The minimum distance between the machine and any other objects in or near the working area should be 30cm. Good ventilation is of critical importance for the normal performance and lifespan of the machine.

2) Welding operation is forbidden while the machine is overload.

Remember to observe the max load current at any moment (refer to the corresponding duty cycle). Make sure that the welding current should not exceed the max load current. Overload could obviously shorten the machine's lifespan, or even damage the machine.

3) Over-voltage is forbidden.

Regarding the power supply voltage range of the machine, please refer to "Main Parameters" table. This machine is of automatic voltage compensation, which enables the maintaining of the voltage range within the given range. In case that the input voltage exceeds the stipulated value, it would possibly damage the components of the machine.

4) Make sure earth connected before operation

There is a grounding screw on the back of machine with a grounding sign beside. Before using, make sure earth connected well to prevent the operator from getting electric shock or electricity leak.

5) Operation over max duty cycle

When using the machine over max duty cycle, inside overheating circuit causes the temperature switch to be open-circuit, which finally prevents the product from working on. This can be judged from the yellow light LED on face panel. Under this circumstance, no need to pull off the plug from the power and keep power on to let the fan cool down the machine. When the yellow LED turns off, welding can be continued.

6) Carrying the machine

When moving the welder, be careful not to be hurt by the machine. When lifting the welder with other equipment like forklift, do not put yourself under it to avoid being hit if the welder drops.

8. Maintenance

Warning

- This machine will produce electric and magnetic fields, so the operator should ensure proper protection and screening while using it.
- Earth leakage-circuit breaker should be used with this machine.
- During operation, DO NOT pull out or insert any plugs or cables. It can lead to fatal danger and cause damage to the machine.
- Before connecting cables, make sure the power is off. (The correct way is to connect the cables to the machine first, and make sure they are firmly tightened and then connect the power plug to the power source.)
- Before maintenance and checking, power must be turned off,
- Before opening the cover, disconnect the machine from power source.

- 1) Remove dust with dry and clean compressed air regularly. If the welding machine is operated in polluted area with smoke and dust, the machine needs to be cleaned regularly.
- 2) Pressure of compressed air must not be higher than 5 bars in order to prevent damage to small components inside the machine.
- 3) Check inside the welding machine regularly and make sure the output terminals are connected tightly and connectors are not damaged. If burnt, loose or damaged, please tighten or replace them if necessary.
- 4) Avoid water and steam entering into the machine. If the welding machine gets wet, please dry inside of the machine and check the insulation status.
- 5) If the machine will not be used for long time, it should be put into a box or covered and stored in cool and dry area.



Correct Disposal of this product

This marking indicates that this product should not be disposed with other household wastes throughout the EU. To prevent possible harm to the environment or human health from uncontrolled waste disposal, recycle it responsibly to promote the sustainable reuse of material resources. To return your used device, please use the return and collection systems or contact the retailer where the product was purchased. They can take this product for environmental safe recycling.

9. Troubleshooting



Warning

Experimentation and careless maintenance may lead to more problems to the machine. This will make professional diagnosis and repair more difficult. When the machine is open, there may be exposed connections containing life-threatening voltages. Any direct or indirect touch will cause electric shock, and severe electric shock will lead to death.

Notes: only attempt to repair this machine if you have knowledge and understanding of electronic components and the danger of high voltage electricity.

Common Malfunction Analysis and Solution:

Malfunction	Cause and Solution
Power indicator is not lit, fan does not work and no welding output	<ol style="list-style-type: none"> 1. Make sure if power switch is working. 2. Check if connection from power switch to power board is in good condition. 3. Check if the plug you are using is working. 4. Check if input voltage is correct. 5. Control board might be faulty.
Power indicator is lit, fan works, no welding output	<ol style="list-style-type: none"> 1. Check if all cables are connected properly. 2. Output connectors are disconnected or damaged. 3. Control circuit might be faulty.
QC(Quality Control) LED is on continuously or when striking an arc	<ol style="list-style-type: none"> 1. The machine can be in over-heat protection. Wait for 15 minutes 2. The machine can be in over-current protection. Turn off the machine for 30 seconds and then switch on again. If QC LED is still on and not working, there is a fault on the board. 3. IGBT on control board might be faulty. 4. Fast recovery diodes or transformer might be faulty.
Output current is not stable	<ol style="list-style-type: none"> 1. Input voltage is not stable. 2. There is harmful interference from input voltage or other equipment. 3. Check if there is any loose contact inside the machine. If any, please reconnect.

If the machine still fails to work after maintenance and troubleshooting, please contact and consult with local distributor or after-sale service center.

10. Exploded Drawing

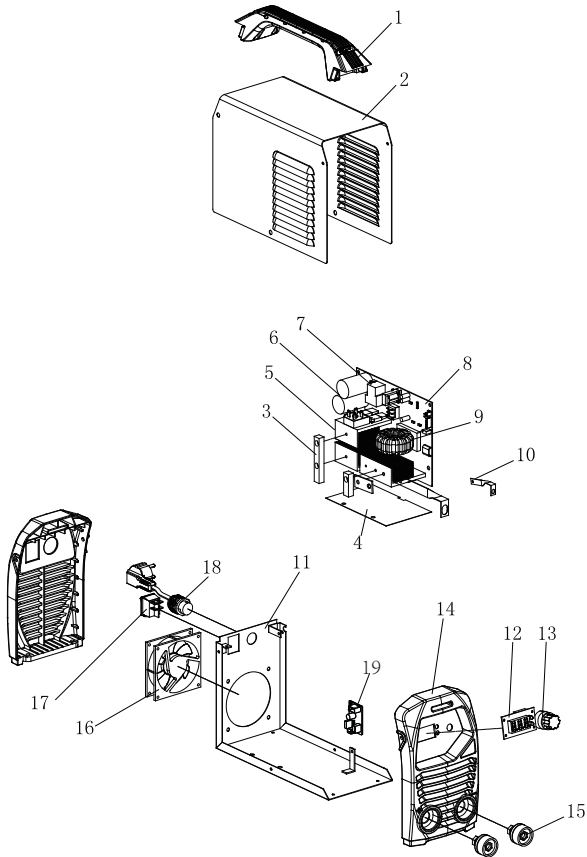

MMA-120/140/160

- | | |
|----------------------|------------------------|
| 1. Handle | 12. Digital display |
| 2. Top cover | 13. Potentiometer knob |
| 3. Pillar | 14. Plastic panel |
| 4. Insulation board | 15. Quick connector |
| 5. Radiator | 16. Fan |
| 6. Capacitance | 17. ON/OFF Switch |
| 7. Relay | 18. Power cable |
| 8. Main PCB | 19. Digital PCB |
| 9. Main transformer | |
| 10. Copper connector | |
| 11. Base | |

EC Declaration of Conformity



We :

HYUNDAI Corporation
25, Yulgok-ro 2-gil, Jongno-gu, Seoul 03143 Korea

Declare that the product detailed below :

DC INVERTER MMA WELDER
MODEL : MMA-120/140/160

Satisfies the requirements of the Council Directives :
EC-Low voltage directive 2014/35/EU
EC Directive of Electromagnetic Compatibility 2014/30/EU
RoHS Directive 2011/65/EU

and conform with the norms :

EN 60974-1 : 2012, EN 62233 : 2008+AC:2008,
EN 60974-10 : 2014, EN 55011 : 2009+A1 : 2010,
EN 61000-3-11 : 2000, EN 61000-3-12 : 2011

General Manager

A handwritten signature in black ink, appearing to be 'Yoonsung Lee', written over a horizontal line.

Yoonsung Lee

Project Manager

A handwritten signature in black ink, appearing to be 'Donghoon Park', written over a horizontal line.

Donghoon Park

Date : 2018.04.23

HYUNDAI Corporation

25, Yulgok-ro 2-gil, Jongno-gu,
Seoul 03143, Korea,
Post Code : 03143

+ 82 2 390 1114
www.hyundaicorp.com

Copyright HYUNDAI Corporation All rights reserved.
Made in P.R.C

HYUNDAI