

Assembly Instructions

Malaren Dining Set Grey

519960-01-01

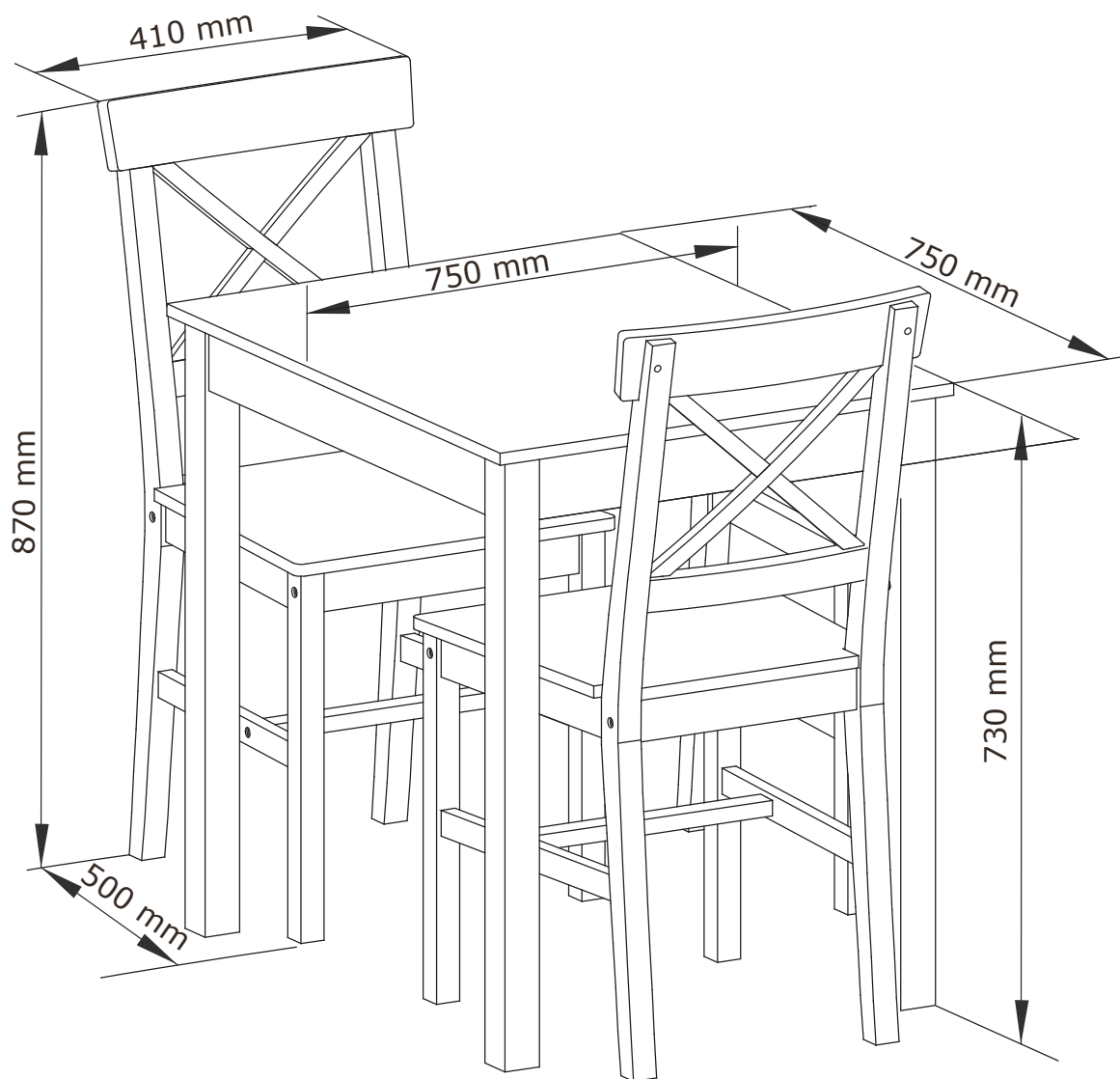

Keep these instructions for future reference

Assemble the furniture on a soft level surface to avoid damaging the furniture or your floor.

We recommend furniture be assembled near where they will be placed, to avoid moving the product unnecessarily once assembled.

If there is a need to move the furniture, please remove all loose items and have extra hands to help lift the furniture to the desired location. Dragging the furniture will damage both the furniture and the floor.

Regularly check and re-tighten (if necessary) all bolts on furniture that you have assembled yourself.

Tools Required

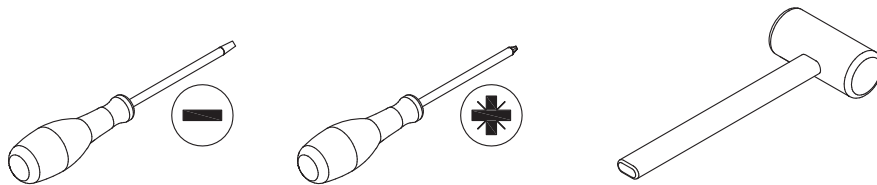

General Care for Longer Lasting Furniture

Always use coasters/placements underneath hot objects, such as pans, plates or glassware to protect the surface of the furniture.

If any liquid is spilled on the wood surface, wipe immediately but gently, using a clean, firmly wrung damp cloth. Dry afterwards using another clean, dry cloth.

For regular cleaning, use a damp cloth or sponge with clean water. Wipe across the whole surface as one.

Do not use spirits, bleaches or any other chemical cleaners to clean furniture.

PARTS LIST

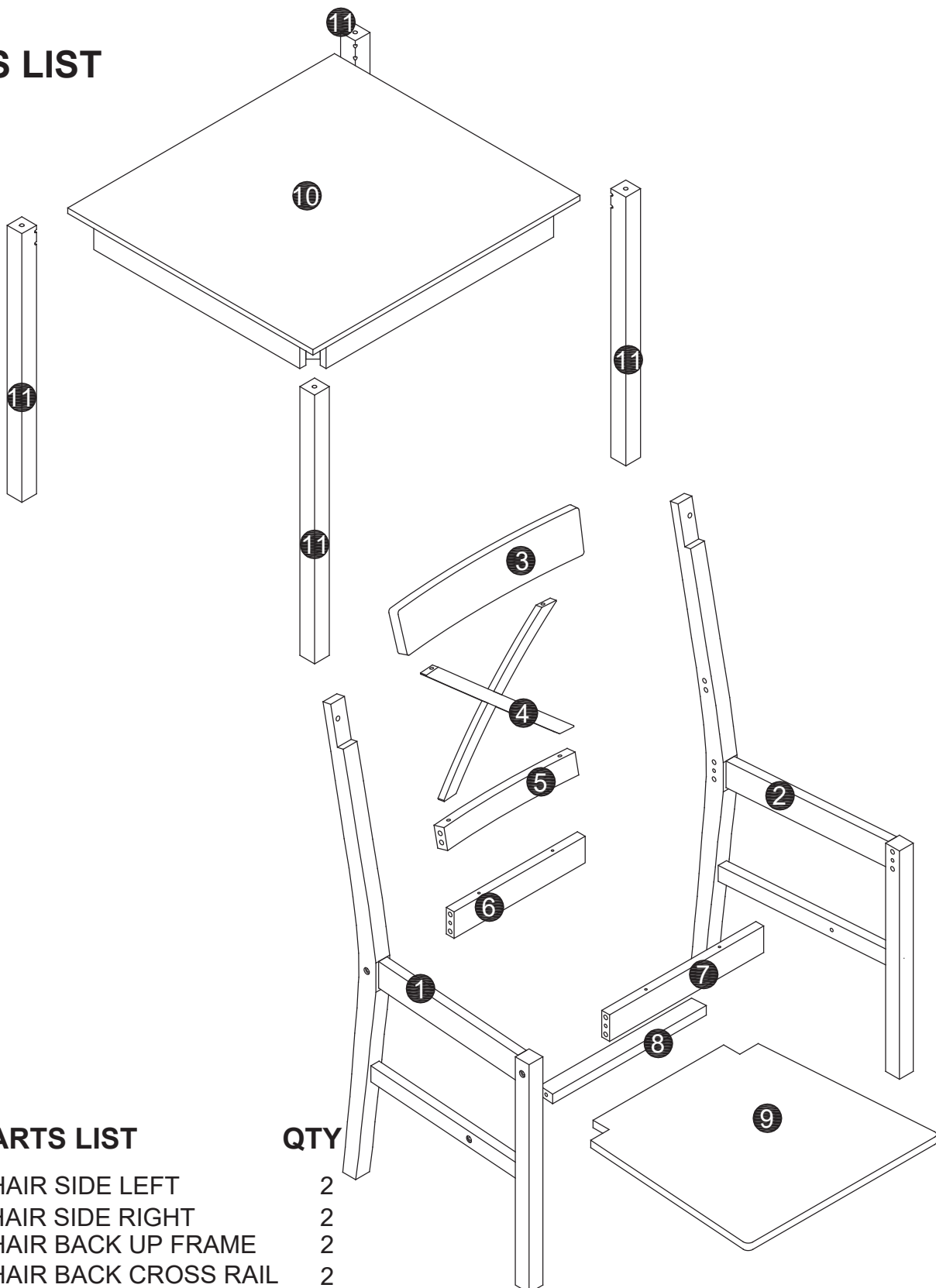

NO	PARTS LIST	QTY
(1)	CHAIR SIDE LEFT	2
(2)	CHAIR SIDE RIGHT	2
(3)	CHAIR BACK UP FRAME	2
(4)	CHAIR BACK CROSS RAIL	2
(5)	CHAIR BACK DOWN RAIL	2
(6)	CHAIR BACK BOTTOM RAIL	2
(7)	CHAIR FRONT BOTTOM RAIL	2
(8)	CHAIR BOTTOM CROSS RAIL	2
(9)	CHAIR SEAT	2
(10)	TABLE TOP	1
(11)	TABLE LEG	4

HARDWARE LIST

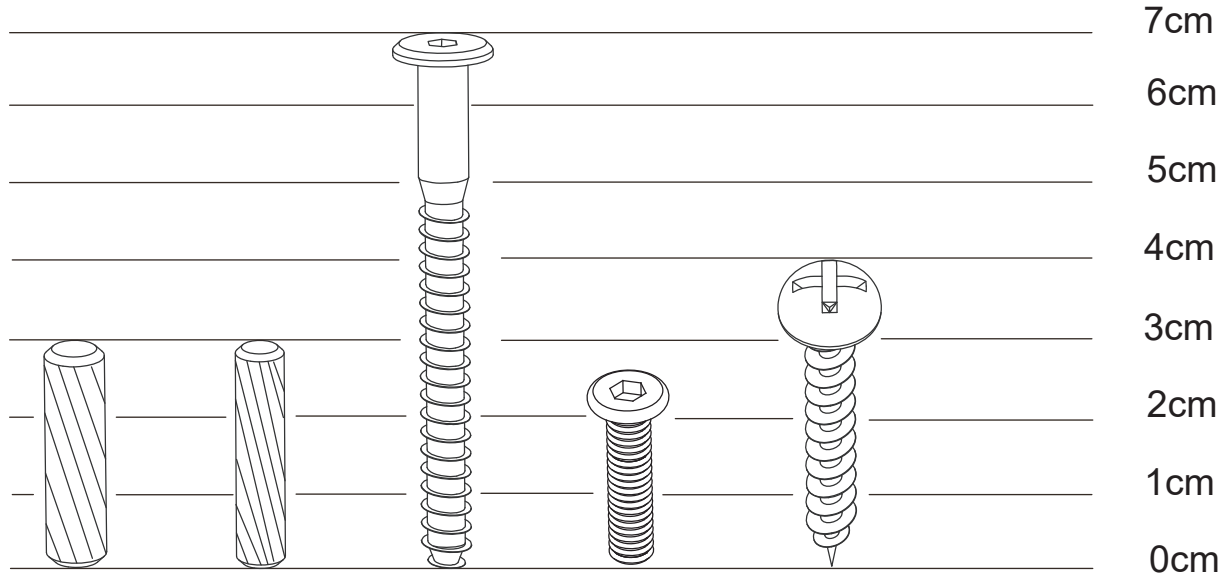

24x
ø8 x 30mm
A
DOWEL

8x
ø6 x 30mm
B
DOWEL

12x
M7 x 70mm
C
BOLT

4x
M6 x 25mm
D
BOLT

8x
ø3.5 x 40mm
E
SCREW



1x
4mm
F
ALLEN KEY

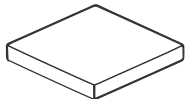

8x
23 x 23mm
G
FOOT

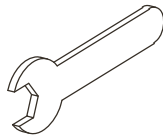

1x
13mm
H
SPANNER

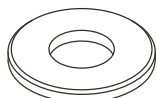

8x
ø8 / 18mm
K
WASHER

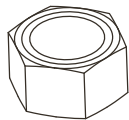

8x
M8 / 13mm
L
HEX NUT

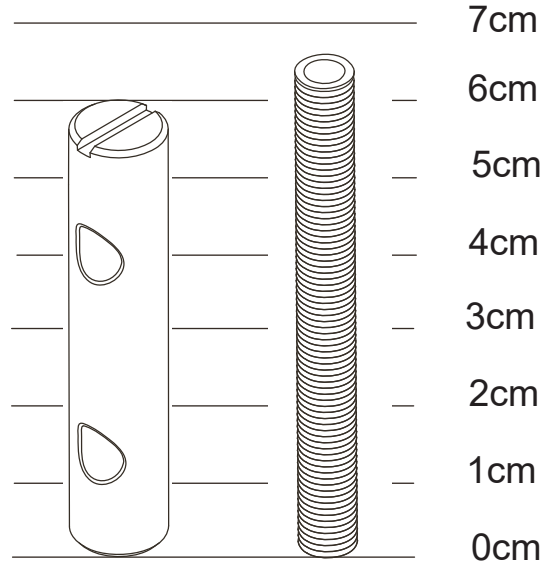

4x
ø12 x 60mm
P
BARREL NUT

8x
M8 x 65mm
J
BOLT

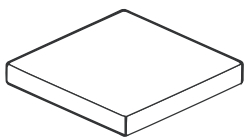

4x
35 x 35 x 2mm
M
FOOT

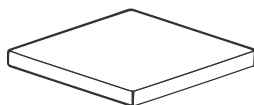

4x
35 x 35 x 1mm
N
FOOT

1

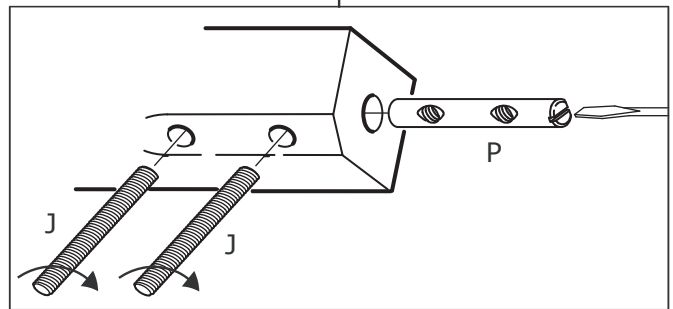
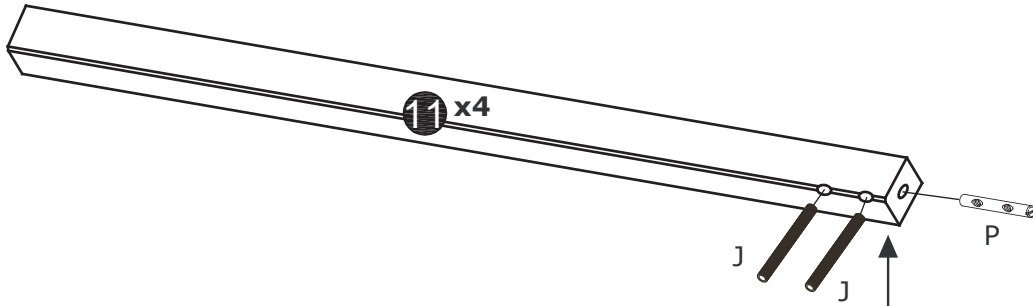

2

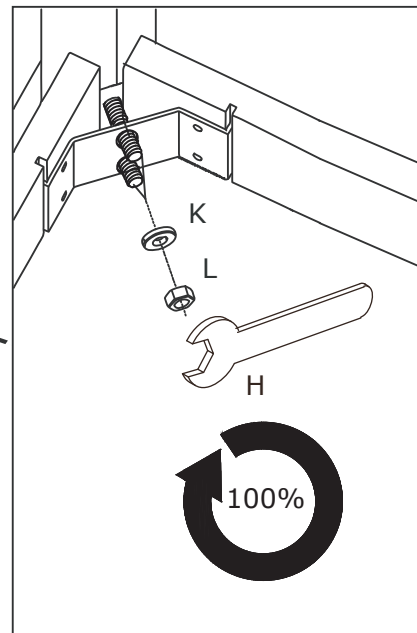
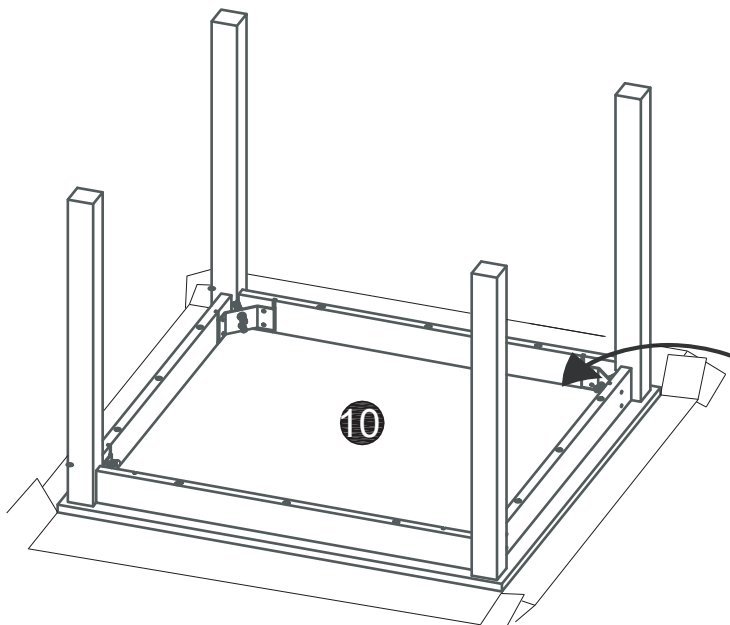

3

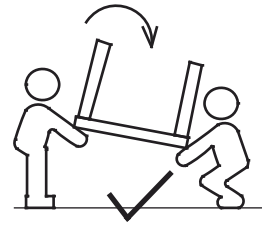
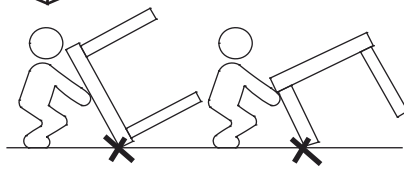
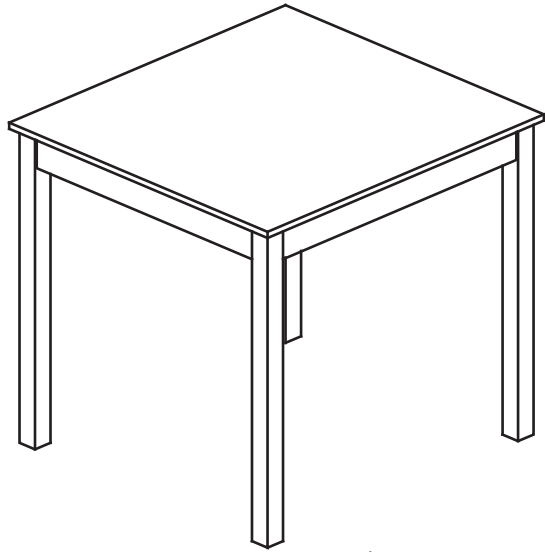
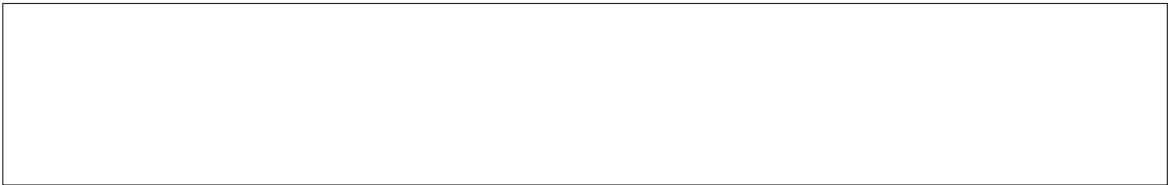

4

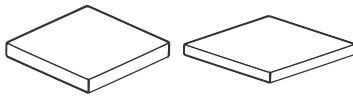

35x35x2 mm
M x 4

35x35x1 mm
N x 4

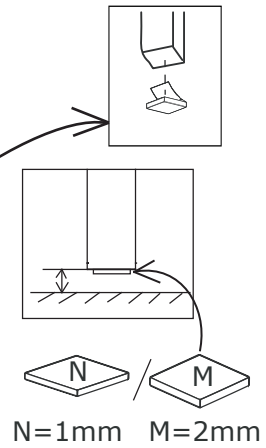
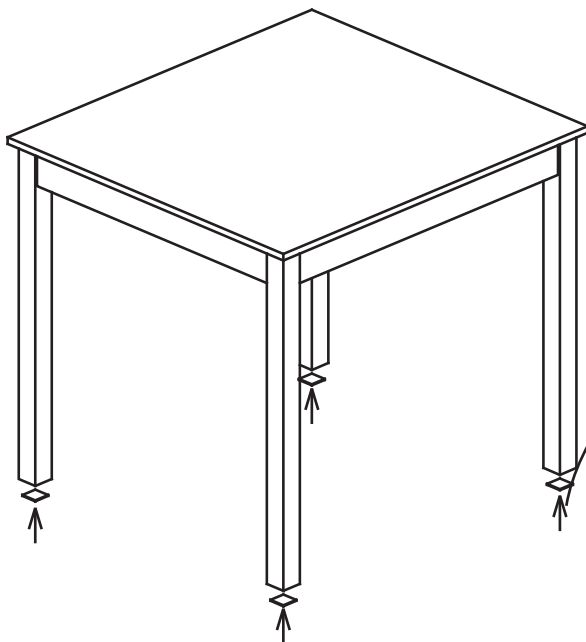

5



Ø8x30 mm
A x 24

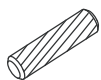

Ø6x30 mm
B x 8

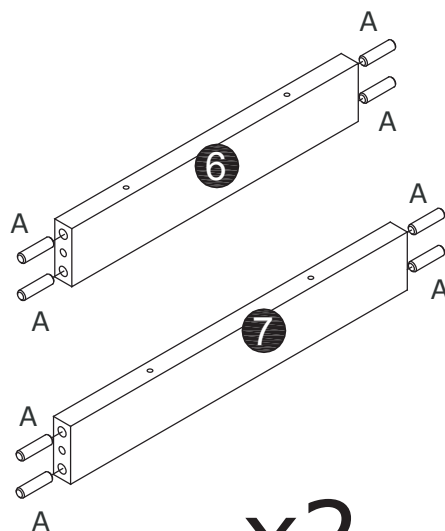
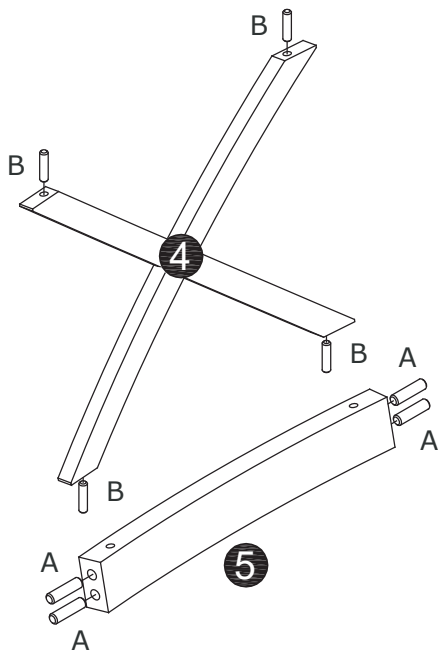
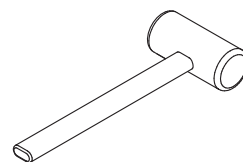

x2

6

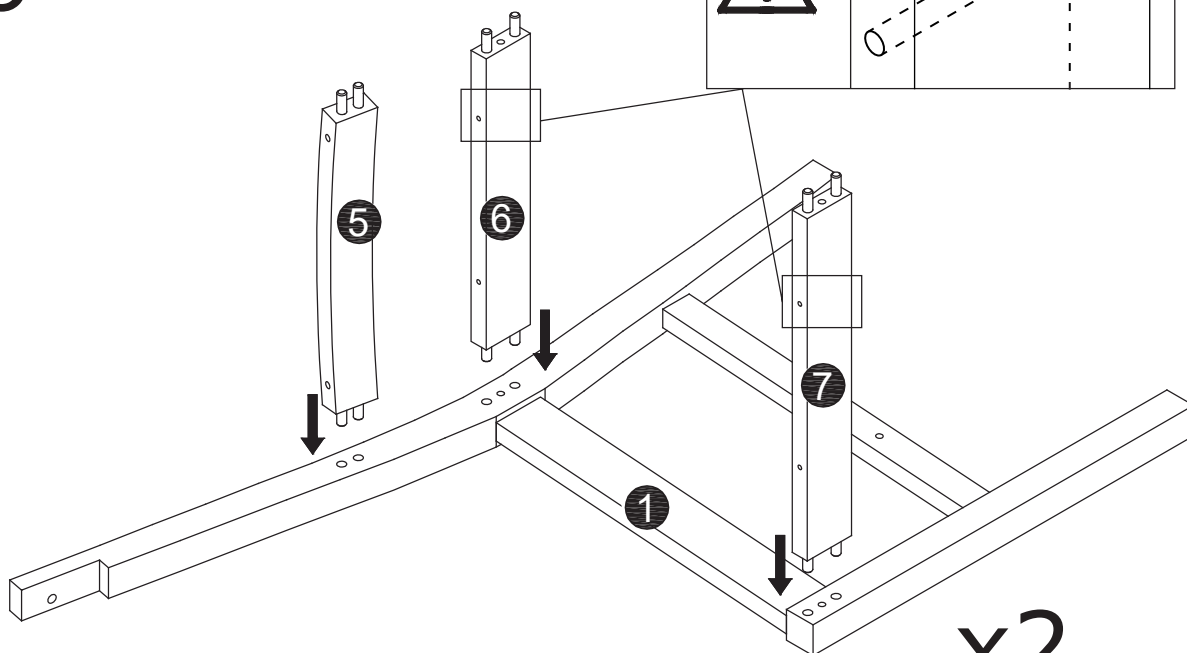
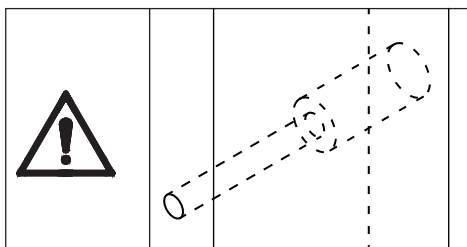

x2

7

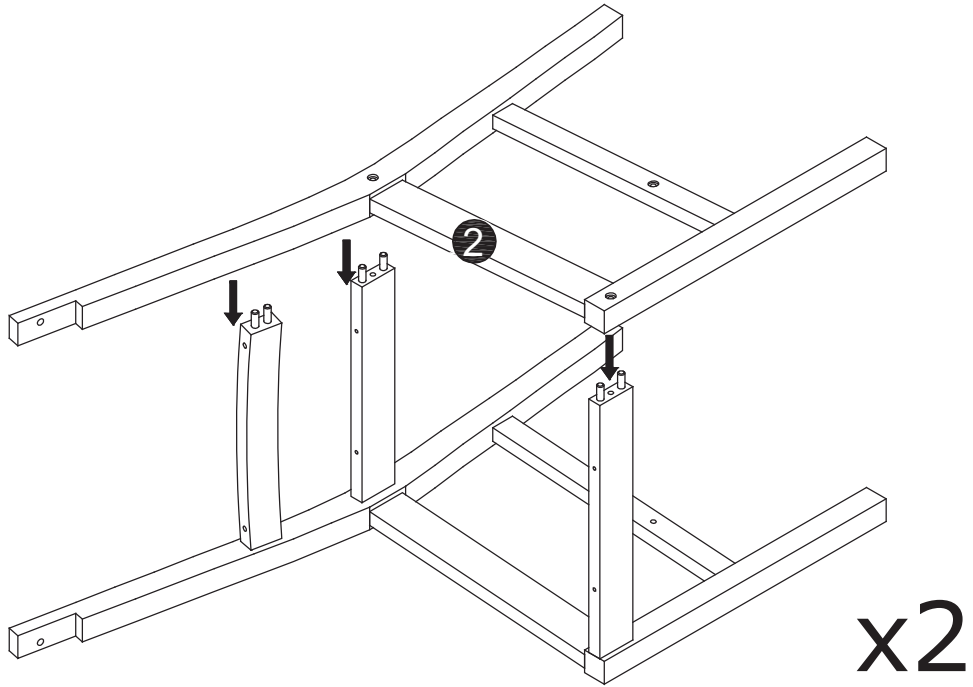

8

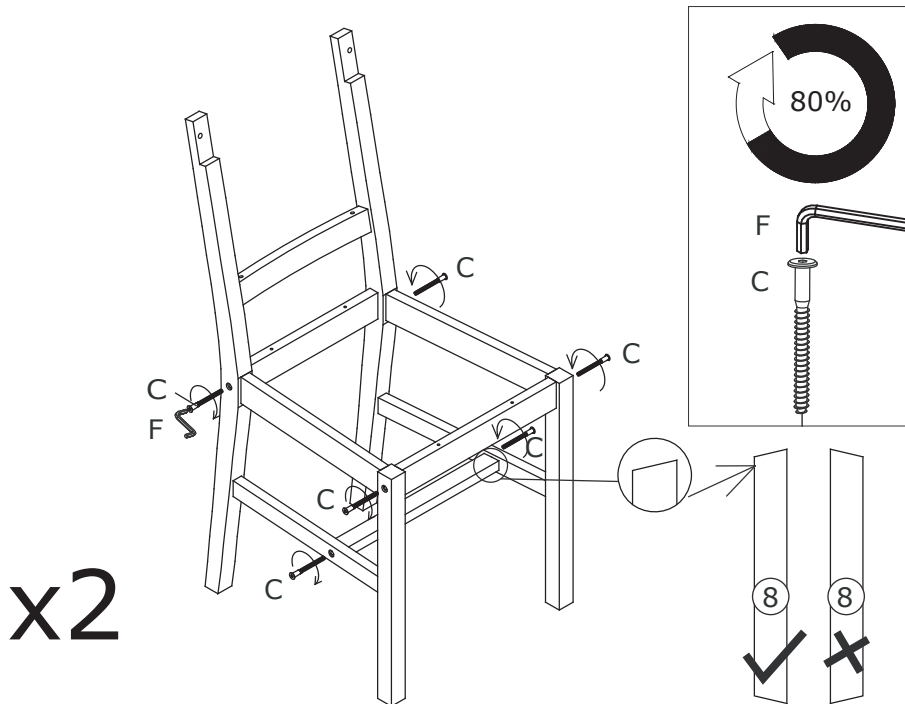

x2

9

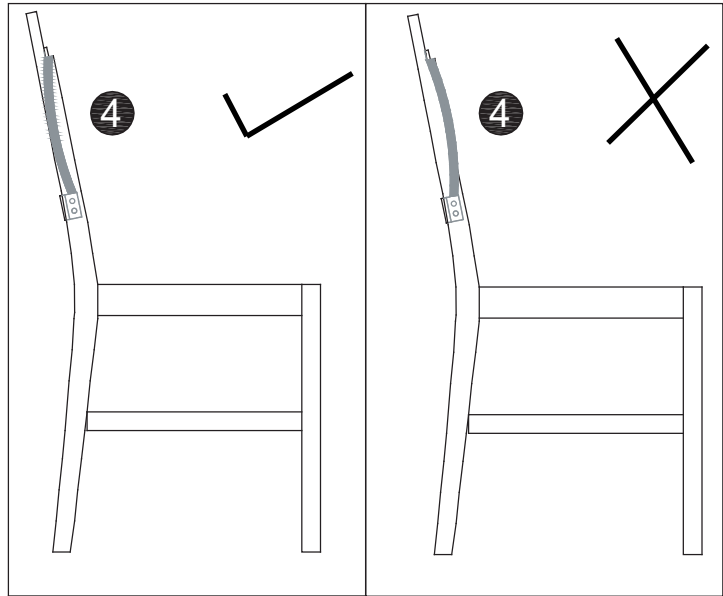
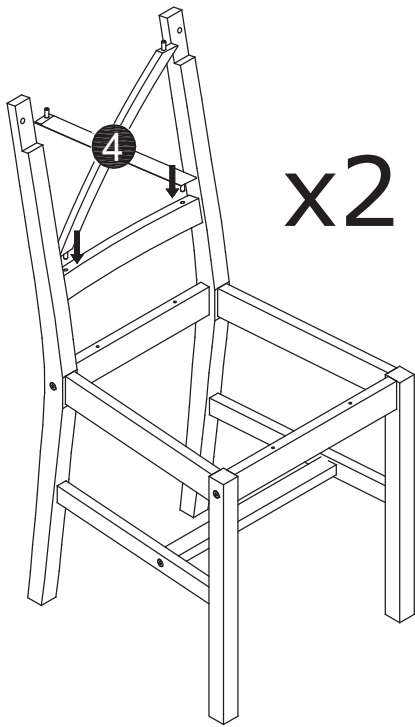

10

M6x25 mm
D x 4

4 mm
F x 1

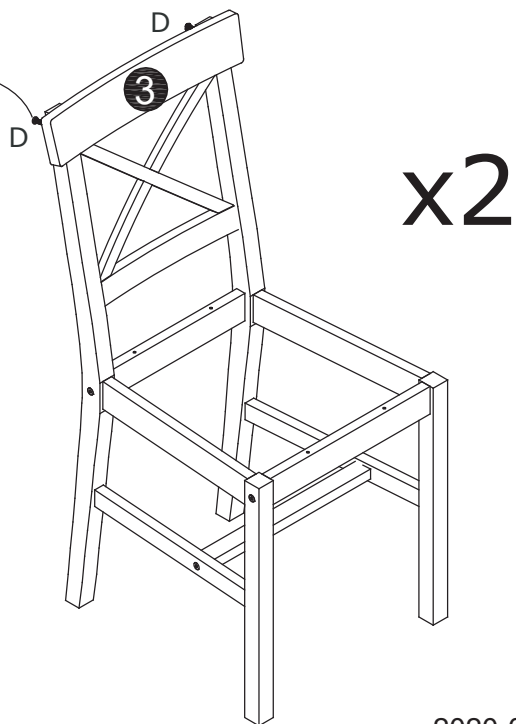
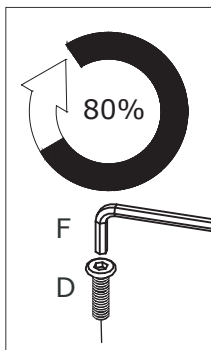
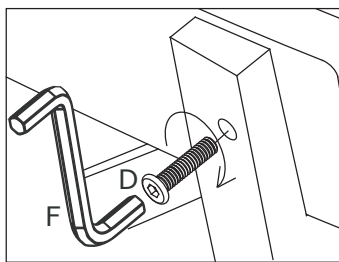

11



4 mm
F x 1

x2

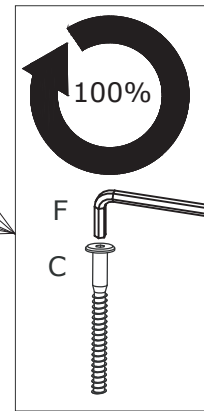
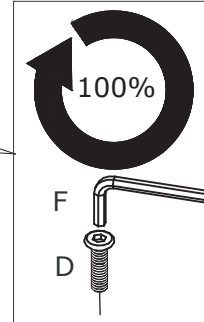
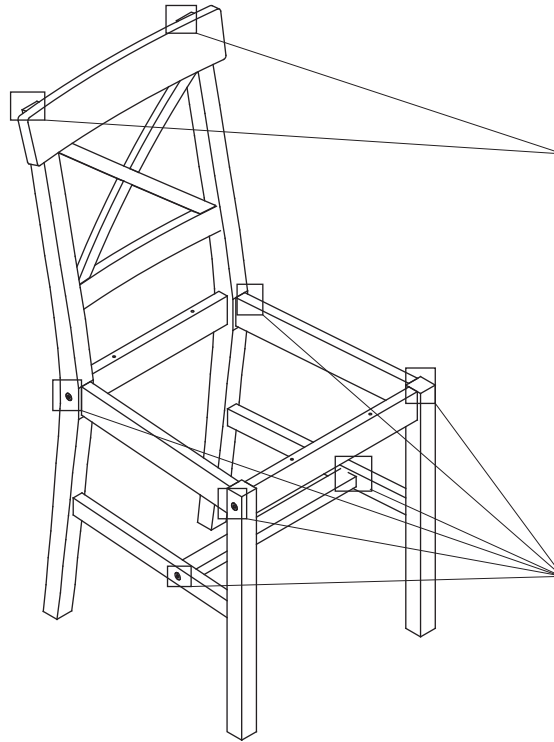

12

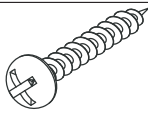

Ø3.5x40 mm
E x 8

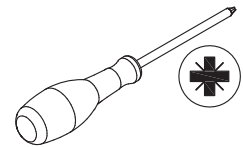

x2

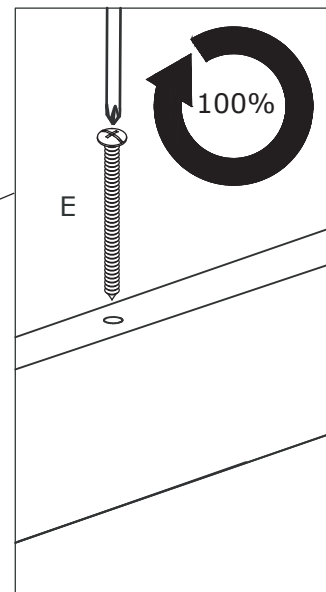
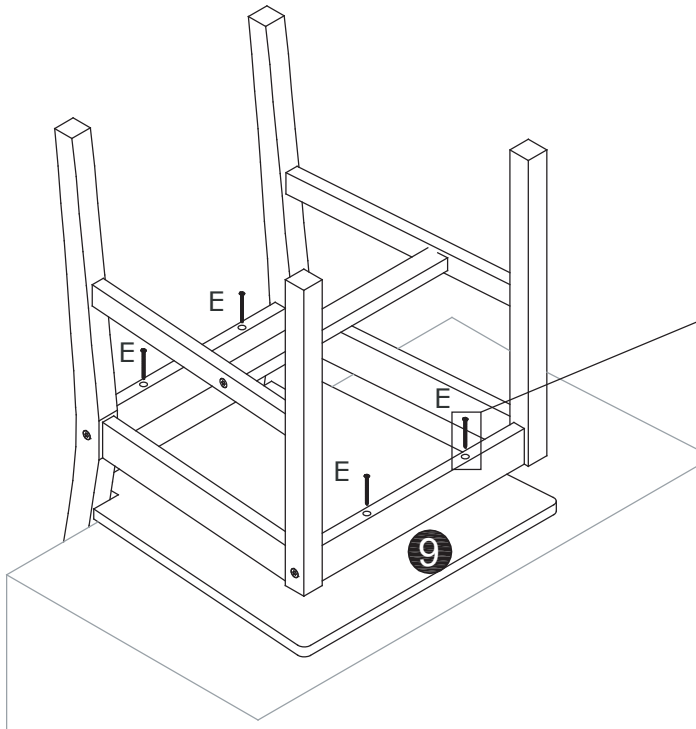

13

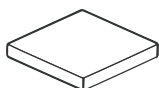

23x23 mm
G x 8

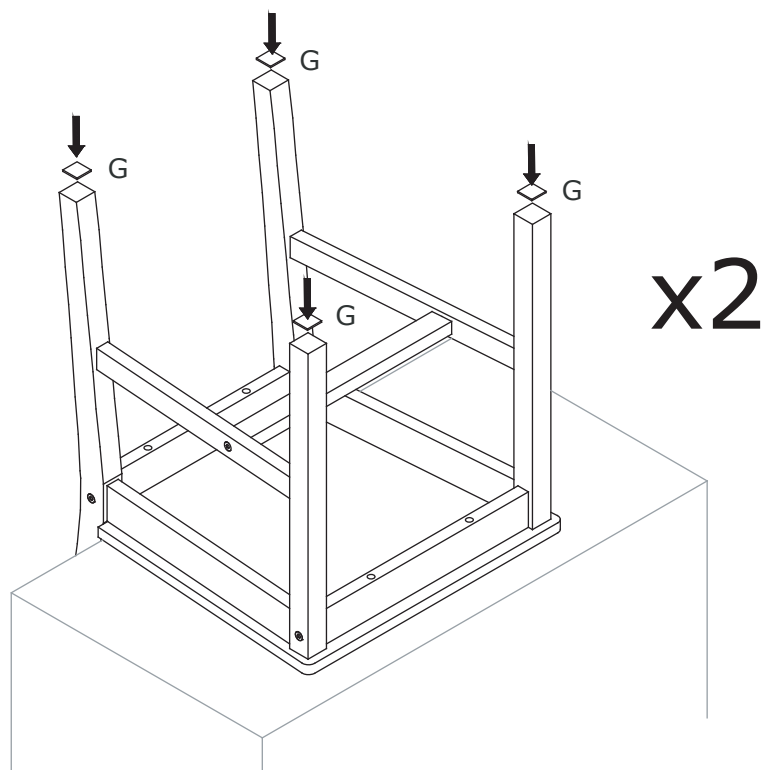

14

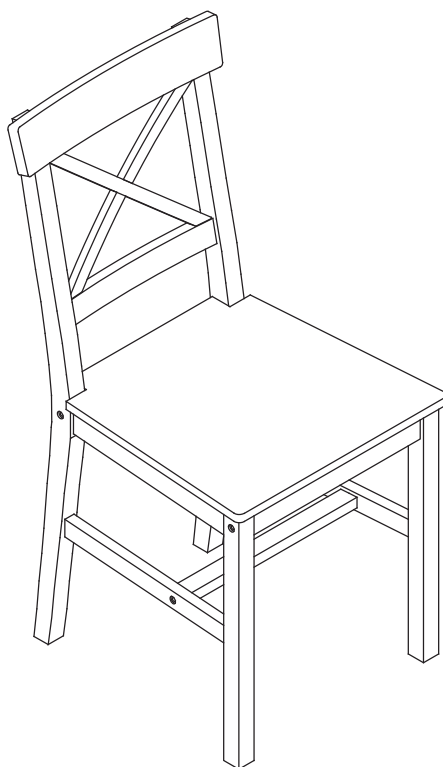

15

