



FITTING AND OPERATING GUIDE

12V / 24V DC ELECTRIC RECOVERY WINCHES.



SL 13,500lb (6124kg)



SL 17,500lb (7938kg)

VERY IMPORTANT - YOU MUST READ AND UNDERSTAND THIS GUIDE BEFORE
INSTALLING AND OPERATING YOUR WINCH

Thank you for buying a WINCHMAX brand winch. By using this product within its limitations and following the instructions provided you can expect many years of trouble-free service.

IMPORTANT

PLEASE READ AND UNDERSTAND THIS ENTIRE MANUAL BEFORE INSTALLING OR OPERATING THIS PRODUCT – FAILURE TO DO SO COULD RESULT IN DAMAGE TO PROPERTY, SERIOUS INJURY OR DEATH. UNDERTAKE A FULL SAFETY CHECK AND RISK ASSESSMENT BEFORE EACH USE.

Whilst we have attempted to provide comprehensive guidance for the safe operation of this winch it remains the operator's responsibility to evaluate and minimise the potential risk before and during every operation. Keep these instructions for reference.

1. WARNINGS AND GENERAL SAFETY INFORMATION

- No loose clothing or jewellery should be worn to prevent entanglement in moving parts.
- Good quality overalls, non-slip protective footwear, thick leather gloves and eye protection should be worn.
- It is the operator's responsibility to ensure he/she and all spectators remain at a safe distance. For spectators, this should be at least 1.5 times the rope length being used.
- Check your winch thoroughly, including all electrical connections before use. Any damaged parts should be replaced, using only genuine parts.
- Protect the winch from shock loads - do not allow the winch rope to be yanked by a rolling load or moving vehicle. Never drive your vehicle to assist the winch in any way.
- If a wire rope breaks or pulls loose under load it can lash back with significant force
- With wire rope, it is a good idea to use a heavy winch blanket/damper draped over the rope towards the hook end to reduce whiplash in the event of rope failure. The vehicle bonnet can be raised to provide additional protection when operating from inside the vehicle
- Do not use winch if the rope is frayed or damaged.
- Never handle hook directly, always use hand saver tab and protective gloves.
- Never hook the winch rope back on itself.
- Always electrically isolate the winch when not in use.
- Do not use the winch as a hoist or for overhead lifting.
- Do not use the winch to lift, support or move personnel.

- Always ensure winch rope re-spools in tight and even wraps on the drum, do not allow cable bunching.
- Never attempt to use a synthetic rope with a roller fairlead designed for wire rope.
- Never approach the winch, hook or cable if someone else is at the controls.
- Always be certain the anchor point can withstand the load and will not slip.
- Protect the wireless remote from any possibility of accidental operation.

2. PHYSICAL INSTALLATION

WARNING: correct installation of your winch is vital for correct and safe operation.

2.1 INSTALLING CONTROL BOX (RECOMMENDED BEFORE FITTING WINCH TO VEHICLE)

When mounting on a 4x4 with a possibility of deep water wading it is good practice to remote mount the control box up under the bonnet to protect the electrics from water.

The control box can be mounted in two positions:

On Cross Bars

- Install the two included aluminium brackets on the bottom of the control box by removing the four nuts on the bottom of the box, then placing the brackets over the bolts and then secure brackets by re-installing the nut. (Fig A) Note: The hooks on the brackets go towards the front of the winch.
- Use caution when installing brackets in order not to push the bolts up into the control box. To help prevent this, install brackets with the control box on its side instead of laying it flat on a table.
- Secure by tightening the screw on the rear of each bracket and add a lock nut. Decide where you want control box over the drum (left, centre, right), then secure using the included screw, L bracket, nut on the rear.
- The screw goes through the aluminium bracket and into the L bracket with the bottom of the L bracket placed into the slot of the rear tie-bar and finally secured more with included lock nut. (Fig A, B)



Fig A



Fig B



Over Motor

- Install the two black motor mount brackets on the bottom of the control box by removing the four nuts on the bottom of the box, then placing the brackets over the bolts and then secure brackets by re-installing the nut.

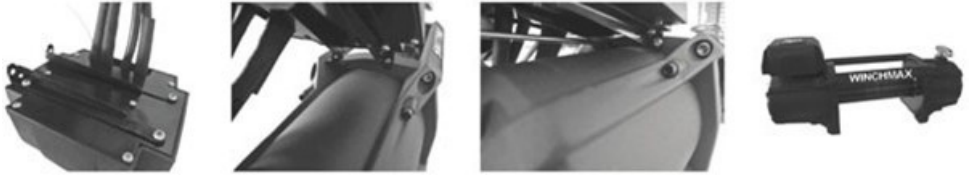

Fig C

- Note: The end of the brackets point outward. (Fig C) Use caution when installing brackets in order not to push the bolts up into the control box. To help prevent this, install brackets with the control box on its side instead of laying it flat.
- Install the control box by lining it up with the two holes on the motor side upright, then Secure with the included hardware.

2.2 MOUNTING THE WINCH (SEE FIG D)

- Install a suitable mounting bumper or mounting plate in the required position. The winch must be mounted with the direction of pull perpendicular to the mounting bolt fixings. The plate should be fabricated from min 6mm steel.
- Attach fairlead (roller type for wire rope or aluminium hawse for synthetic rope) to the mounting plate using two nuts (9) & bolts (1) with flat (7) and spring (8) washers.
- Insert the four square nuts (2) into the pockets at the base of the winch frame.
- Thread the four high tensile bolts (5) with flat (3) and spring (4) washers up through the mounting plate and into the square nuts in the winch. Tighten the mounting bolts to a torque setting of 60Nm
- The supplied bolts are the correct length for installation on a 6-7mm plate. Other thicknesses may require bolts of a different length. The required criteria are that the bolts are at least 8.8 grade high tensile, the thread length should be sufficiently long to fill the thread of the square nut without contacting the top of the mounting nut pocket in the winch base.
- If the rope is pre-spoiled, feed the thimble eye on the hook end through the roller fairlead (6) from the winch side and attach the clevis hook. If you are installing a synthetic rope with a hawse fairlead or if the rope is fitted with a fixed competition hook, you will need to pull off the rope and then feed it back through from the front side of the fairlead.
- If the winch has a 'through the drum' type fixing, undo the allen head grub screw and

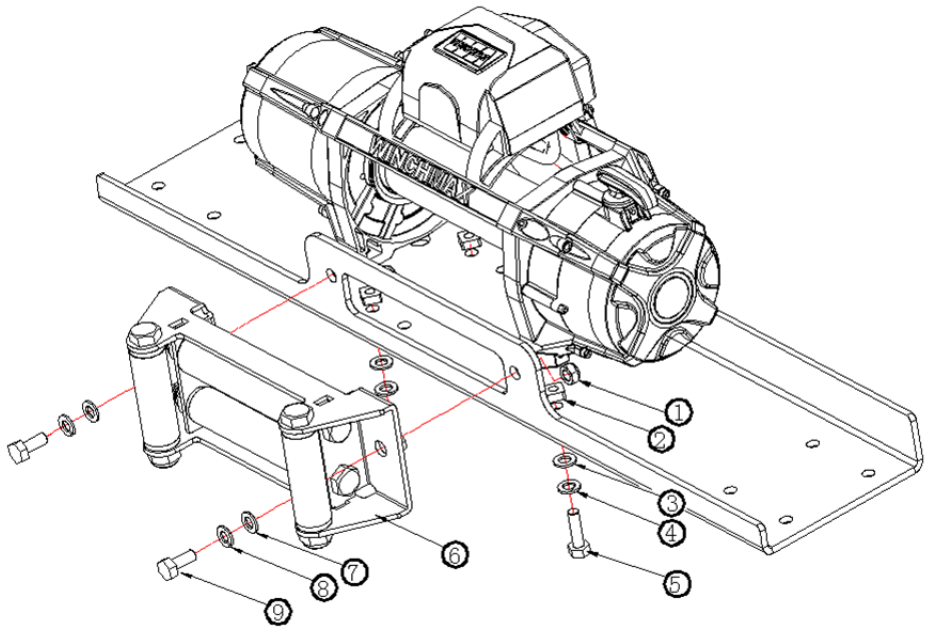

Fig D

feed the end of the rope through the hole until it is visible on the other side, Secure the grub screw. If the winch has a flange type fixing then secure the ring terminal at the end of the rope using the allen head cap screw, but only finger tight to allow the fixing to swivel on the screw. Spool the rope as per Section.4.

3. ELECTRICAL INSTALLATION (SEE FIG E)

- Ensure your battery is in good condition and can provide a minimum of 650 CCA
- Route the supplied battery leads (long red lead from control box = Positive/separate long black lead = Negative) directly to the battery location, ensure that the cable is protected throughout its run from heat and abrasion against sharp components.
- Connect the negative battery lead to the winch motor earth terminal (never use a chassis earth)
- Connect the remaining cables from the control box to the motor observing the colour coded boots on the cable and corresponding colour coded collars on the motor terminals.
- Ensure that the small earth wire from the control box (this is the earth supply to the contactor) is connected to the main battery fed earth terminal on the underside of the motor (do not attempt to use a chassis earth).
- When you are satisfied that all other connections are correctly installed connect the battery leads to the battery (via an isolator switch and the overload cut out if being used)

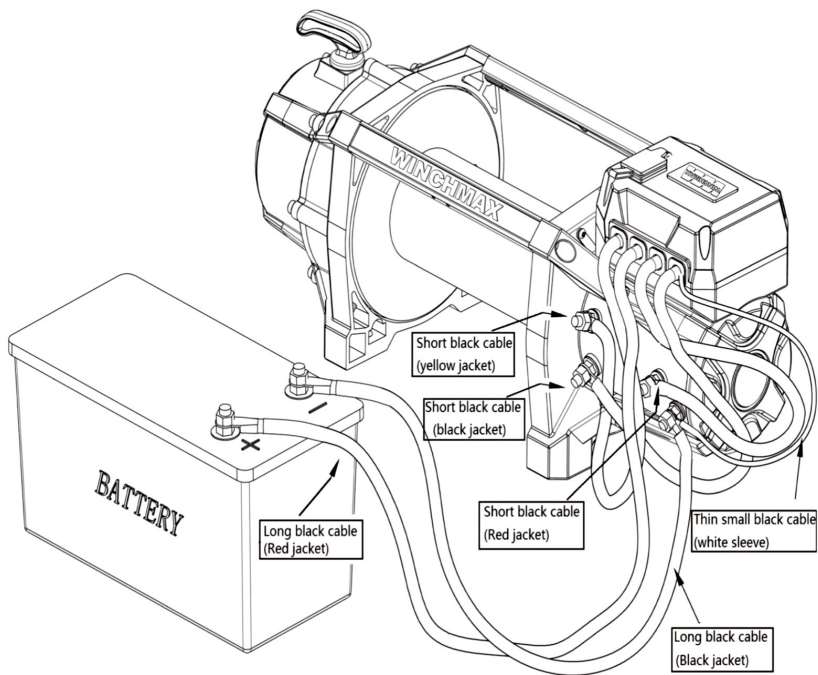

Fig E

Notes

- If you need to extend the cables, use minimum 40mm² flexible welding cables.
- Always fit a battery isolator switch to the positive supply line to allow for emergency stop and to prevent unintentional starting and to protect the winch if the vehicle is jump-started.
- All earth connections must be fed from the battery, never attempt to use a chassis earth
- Check all connections are secure and protect from corrosion with petroleum jelly, copper grease or similar.
- If there is an overload circuit breaker supplied please mount this in line with the positive supply (fix one end to the battery terminal, and connect the positive supply lead to the winch on the other)

Remote Control

- The remote control is a combined wired / wireless unit in one with a removable lead.
- Once the winch has been set-up then the remote hand control can be operated either in the WIRED OR WIRELESS mode.
- It is recommended that for the initial set-up of the winch (before applying any load) that the winch be operated in the WIRED mode.



Fig G



Fig H



- Take care when inserting the wireless remote plug into the control box socket, you must line up the socket end (Fig. G) with the groove in the socket (Fig. H)
- To use the remote hand controller in the WIRELESS mode remove the control cable from the control box, unplug the remote hand controller from the control cable and press the MODE button on the remote hand controller until the green light marked WIRELESS is illuminated.
- Make sure winch remote indicator light is in the correct mode before using.
- Use the thumb switch to operate the winch 'IN' or 'OUT'

4. SPOOLING THE ROPE

- We recommend the use of an assistant when spooling the rope.
- Spooling should be undertaken on a large open and level area.
- First, lay out the rope in front of the vehicle ensuring there are no twists or kinks.
- With the winch clutch disengaged, feed the drum terminal through the front of the roller/hawse fairlead and connect to the drum using the button head Allen screw provided, this should be finger tight only so that the ring terminal can rotate if necessary.
- Attach the hook end to a suitable anchor point and position the vehicle so there is at least 3m of slack on the rope. Apply the vehicle hand brake.
- Holding the rope with gloved hands and at least 5m back from the winch apply as much pressure as you can by leaning your body weight against the rope and walking towards the winch whilst using the wired remote to wind in. Ensure that each wrap lays tightly next to the other until the rope tensions against the anchor point. There should be at least 6 wraps around the drum.
- The rope must be wound onto the drum from the bottom of the drum.
- Using the wired remote and whilst gently applying the vehicle foot brake to maintain tension, use the winch to pull the vehicle towards the anchor point.
- During the operation, regularly stop the winch, apply the handbrake to maintain tension and check the rope is spooling on evenly to the winch.
- If you have an assistant, they should remain in the vehicle to operate the brake, whilst you maintain control of the winch from outside the vehicle and using the wired remote.

- When the rope is all but approx. 3m spooled in, using the hand save to hold the hook, reverse the winch slightly to allow the hook to be released.
- Maintaining tension on the rope, pulse the remote to take in the remaining rope and then anchor the hook onto a suitable mounting point on the vehicle.

Notes

- It is important to understand that it is the first 6-8 tight wraps around the drum and NOT the drum terminal fixing point that allows the wire or synthetic rope to grip onto the drum.
- If used the ring terminal crimped onto the cable for attachment to the drum flange and the fixing screw are not load-bearing, they are only designed to allow the cable to be wound on under sufficient load for it to wrap tightly onto the drum.
- When wire rope is new it is greasy and springy and can easily unwind on the drum if tension is ever released.
- If the outer wraps of a wire rope do 'unwind' then you must pull the whole rope out and re-spool under tension. Failure to observe this will result in failure of the drum fixing.

5. WINCH OPERATION

- Ensure vehicle is secure by applying parking brake or chocking wheels.
- Power out (for a short distance) or free-spool the cable out and connect to a suitable anchor point
- Re-check all cable rigging before commencing.
- Plug in the winch hand controller and switch on the battery isolator if fitted. Feed the hand controller around the front of the vehicle and through the driver's window.
- To commence winching, start the vehicle engine and with the transmission in neutral operate the winch whilst guiding the path of the winch with the vehicle steering until free.
- You must ensure that the cable winds evenly onto the drum. Acute angle winching can result in rope bunching on the drum which could break out the winch crossbars.
- When the operation has been completed, the rope should be pulled out and re-spooled neatly under tension for the next use.

Notes

- Your winch is not designed to be used continuously but instead to provide the high load short duration pulls required to recover an off-road vehicle from difficulty.
- Never allow the winch motor to stall.

- Whenever you work your winch it will generate heat in the motor, high loading and/or long or repeated operation can cause the motor to overheat. Always monitor motor temperature; if the motor becomes too hot to comfortably hold your bare hand on stop operation immediately and allow to cool before further use.
- Do not exceed the maximum rated load of your winch.
- We recommend the use of a snatch block and double line technique for any loads exceeding 50% of winch rating. Always anchor hook back to suitable chassis fixing not the winch mounting plate
- Keep the vehicle engine running while winching to maintain battery charge.
- A minimum of 6 tight wraps on the drum must be maintained to prevent failure of drum fixing. Do not pull wire rope out past the red marking.
- Do not disengage the clutch while under load.
- Do not re-engage clutch while the winch is running.
- Never drive your vehicle to assist the winch in any way

6. MAINTAINING YOUR WINCH

- The winch should be exercised at least once a month: Power out approx. 10m of cable, free spool 5m, then power back in under minimum 100kg load.
- Replace remote control batteries every 12 months or when exhausted.
- Keep protective winch cover fitted when the winch is not in use.
- All moving parts are permanently lubricated with grease and with normal use do not need greasing for the life of the winch.
- Clean your winch after use, use only low-pressure water and a brush to rinse off any dirt. Run the winch for a minute or two after cleaning to warm up motor and assist drying.
- Once dry you should use a light spray oil to coat the winch and wire rope before installing the winch cover.
- The winch should not be immersed in dirty water.

7. SYNTHETIC ROPE

- Do not allow the rope to contact sharp or abrasive objects
- The winch should not be immersed in dirty water.
- Do not expose to strong detergents, fuels, oils or anti-freeze solutions.
- After use; pull out the rope, wash, dry and carefully re-spool onto the drum.

Specifications SL13,500Lb Winch

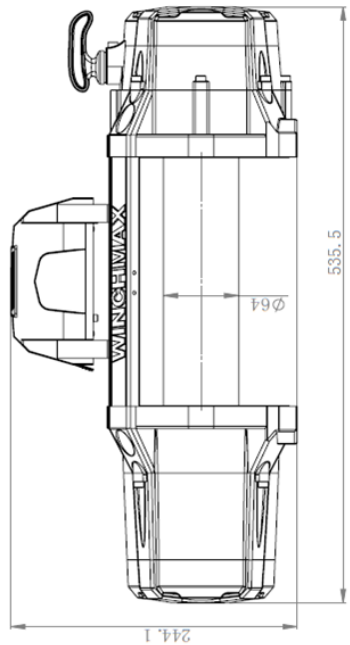
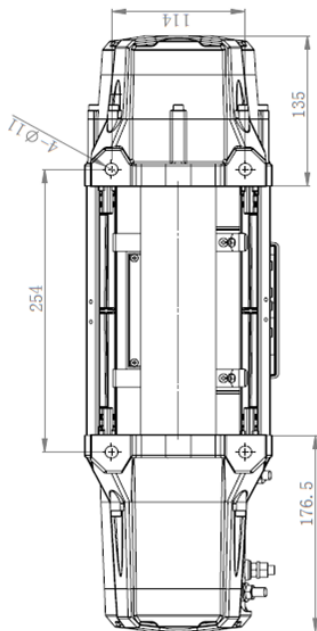
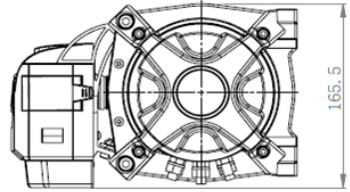
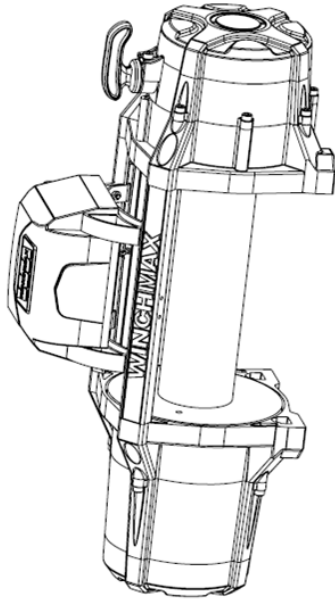

Technical data SL13,500Lb Winch

Waterproof:	IP68 Rating	Fairlead:	4-Way Roller
Rated Max Line Pull:	13,500Lbs(6,124kgs) single-line	Remote Control:	Integrated wireless and wired remote Included
Motor:	6.6hp Series Wound	Recommended Battery:	650CCA Minimum for Winching
Control:	Remote Switch, 12' (3.7m) lead	Battery Leads:	25mm2 x 72" (1.83m)
Gear Train:	3-Stage Planetary	Finish:	Textured Orange
Gear Ratio:	254:1	Weight:	92.0Lbs (42.0Kgs)
Clutch:	Sliding Ring Gear	Mounting Bolt Pattern:	10.0" (254mm) x 4.50" (114mm)
Brake:	Automatic Out-Of-Drum	Overall Dimension	L 535.5 x W 165.5 x H 244.1 mm
Drum Size:	Diameter 2.5" (63mm) Length 10.0" (254mm)	Cable:	78' (24m) x 3/8" (9.5mm) Diameter

Layers Of Cable		1	2	3	4
Rated Line pull per layers	lbs	13500	9530	7929	6770
	kg	6124	4332	3604	3077
Cumulative cable capacity	ft	18	37	64	98
	m	65.4	11.4	19.4	30

Line Pull	lbs	0	3000	6000	9000	13500
	kg	0	1363	2727	4090	6124
Line Speed	ft/min	24.6	11.48	8.86	7.22	5.58
	m/min	7.5	3.5	2.7	2.2	1.7
Motor Current	Amps	70	138	218	260	330

SL13,500Lb parts diagram

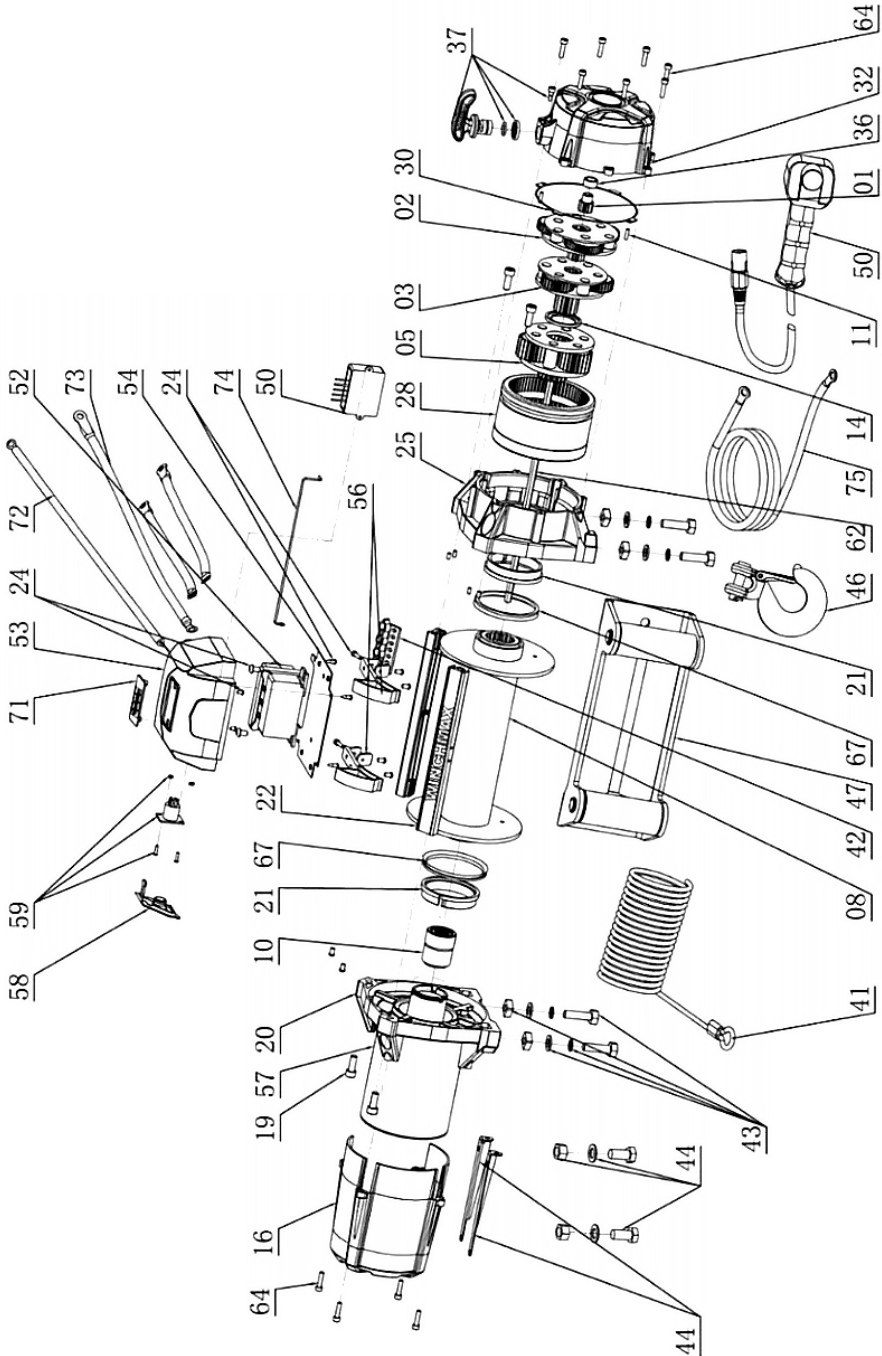

Parts List SL13,500lb Winch

No.	Description	No.	Description
1	Sun Gear	43	Winch Mounting Hardware Set
2	Gear Carrier, Input	44	Mounting Hardware
3	Gear Carrier, Intermediate	46	Clevis Hook
5	Gear Carrier, Output	47	Roller Fairlead
8	Drum	49	Control Box Assy Without Transmitter
10	Break Assy	50	Remote Control With Transmitter
11	Pin M4 X 14	52	Solenoid Assy
14	Rubber Washer	53	Control Box Cover
16	Motor Cover	54	Control Box Base
19	Tie Rod Screw	55	Complete Gear Assy
20	Motor Base	56	Control Box Mounting Hardware
21	Sliding Bearing	57	Complete Motor Assy
22	Tie Bar	58	Socket Cover
24	Control Box Mounting Brackets And Hardware	59	Socket Connector Assy
25	Gear Box Base	62	Drive Shaft
28	Clutch Gear	64	Hexagon Head Bolt M5 X 20
30	Rubber Seal	67	Rubber Seal
32	Gear Box Cover	68	Decal Set
36	Oil Bearing	71	Aluminium Winchmax Badge
37	Clutch Handle Assy	72	Cable Battery(+)
41	Wire Rope With Fix Bolt	73	Cable Battery(-)
42	Wire Rope Fix Bolt Only		

Specifications SL17,500Lb Winch

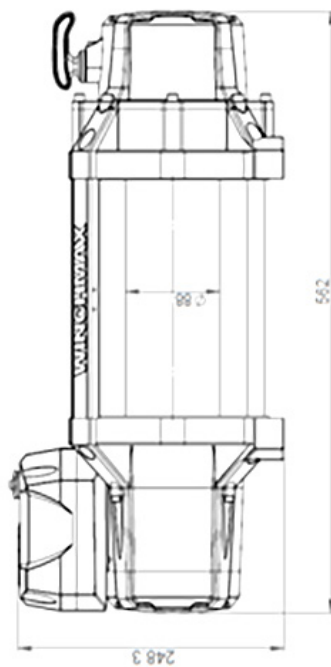
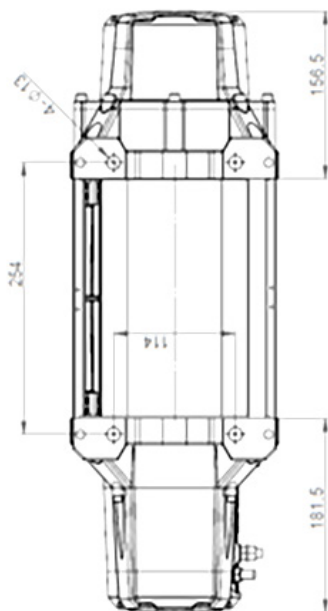
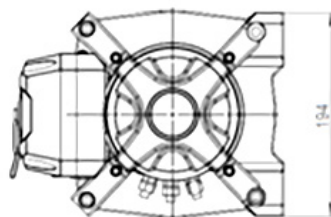
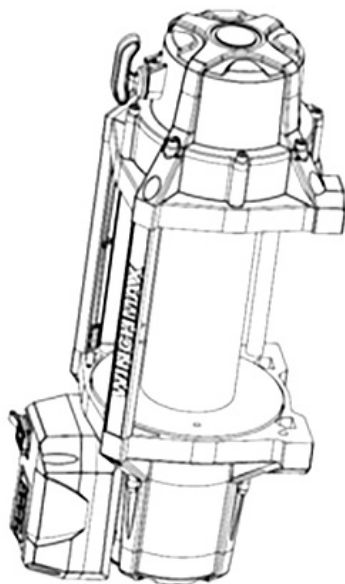

Technical data SL17,500Lb Winch

Waterproof:	IP68 Rating	Fairlead:	4-Way Roller
Rated Max Line Pull:	17,500Lbs (7,954kgs) single-line	Remote Control:	Integrated wireless and wired remote Included
Motor:	6.6hp Series Wound	Recommended Battery:	750CCA Minimum for Winching
Control:	Remote Switch, 12' (3.7m) lead	Battery Leads:	30mm2 x 72" (1.83m)
Gear Train:	3-Stage Planetary	Finish:	Textured Orange
Gear Ratio:	430:01:00	Weight:	130.0Lbs (60.0Kgs)
Clutch:	Sliding Ring Gear	Mounting Bolt Pattern:	10.0" (254mm) x 4.50" (114mm)
Brake:	Automatic Out-Of-Drum	Overall Dimension	L 562 x W 194 x H 248.3 mm
Drum Size:	Diameter 3.45" (88mm) Length 10.0" (254mm)	Cable:	78' (24m) x 1/2" (13mm) Diameter

Layers Of Cable		1	2	3	4
Rated Line pull per layer	lbs	17500	15225	13246	11524
	kg	7955	6920	6021	5238
Cumulative cable capacity	ft	19.68	45.92	75.44	85.28
	m	6	14	23	26

Line Pull	lbs	No Load	6000	10000	12000	14000	17500
	kg	No Load	2721	4536	5454	6363	7937
Line Speed	ft/min	23.62	9.18	5.9	4.92	4.26	2.95
	m/min	7.2	2.8	1.8	1.5	1.3	0.9
Motor Current	Amps	71	200	300	350	395	450

SL17,500Lb parts diagram

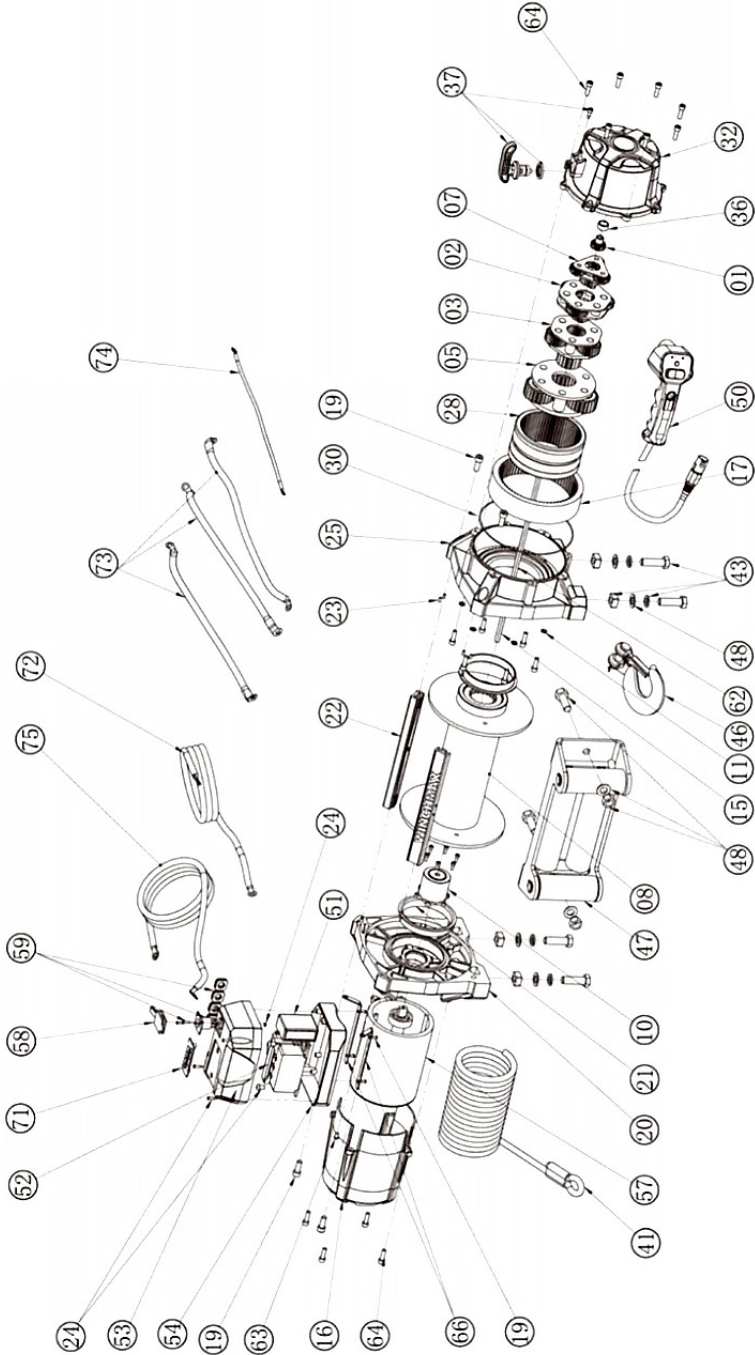

Parts List SL17,500lb Winch

No.	Description	No.	Description
1	Sun Gear	43	Winch Mounting Hardware Set
2	Gear Carrier, Input	46	Clevis Hook
3	Gear Carrier, Intermediate	47	Roller Fairlead
5	Gear Carrier, Output	48	Roller Fairlead Mounting Hardware
7	Gear Carrier	49	Control Box Assy W/O Transmitter
8	Drum	50	Remote Control W/ Transmitter
10	Break Assy	52	Solenoid Assy
11	Washer	53	Control Box Cover
15	Circlip	54	Control Box Base
16	Motor Cover	55	Complete Gear Assy
17	Ring Gear	57	Complete Motor Assy
19	Tie Rod Screw	58	Socket Cover
20	Motor Base	59	Socket Connector Assy
21	Axle Sleeve	62	Drive Shaft
22	Tie Bar	63	Bolt M5 X 8
23	Pin M4 X 8	64	Hexagon Head Bolt M6 X 20
24	Control Box Mounting Brackets and Hardware	66	Motor Gear
25	Gear Box Base	68	Decal Set
28	Clutch Gear	71	Aluminium Winchmax Badge
30	Rubber Seal	72	Cable Battery(+)
32	Gear Box Cover	73	Cable Battery(-)
36	Oil Bearing	74	Ground Cable
37	Clutch Handle Assy	75	Cable Motor
41	Wire Rope With Fix Bolt		

Troubleshooting

Symptom	Possible cause	Remedy
Winch will not operate	Loose, damaged or corroded wiring	Check all wiring and connections to ensure good condition
	Either wireless or wired controls defective.	Test using other control system
	Winch supply battery inadequate	Check voltage of supply battery matches winch
	Motor has burnt out	Test motor by direct connection and replace if required
Runs in only one direction	Loose, damaged or corroded wiring	Check all wiring and connections to ensure good condition
	Motor connection stud(s) have been overtightened and snapped internal weld	Replace motor
	Wander lead not correctly connected	Check wander lead is correctly inserted into control box socket (& rotated to lock position if bayonet type)
Will not free spool	Free spool not dis-engaged	Disengaged free spool
Load does not hold	Free spool not engaged	Engage free spool
	Brake unit has failed	Replace brake unit
	Winch rope has come off drum fixing	Re-fix rope to drum
Winch runs in opposite direction	Yellow and black terminal connections reversed	Swap connections to Yellow and black terminals
	Wireless receiver output wires connected in reverse	Swap wireless receiver output wire connections
Motor runs extremely hot	Long period of operation	Stop operation to let the unit cool down
	Weight overload	Reduce load



WINCHMAX LTD

The Powerhouse,
Earsham Hall,
Bungay,
Suffolk,
NR3452AN.

info@winchmax.co.uk
Tel +44(0)1986899266

Registered in England No. 4083040

WINCHMAX LTD
WWW.WINCHMAX.CO.UK