

IT ISTRUZIONI DI MONTAGGIO  
FR INSTRUCTIONS DE MONTAGE  
EN ASSEMBLING INSTRUCTIONS  
ES INSTRUCCIONES DE MONTAJE  
DE MONTAGEANLEITUNGEN

## OLYMPIC PLUS

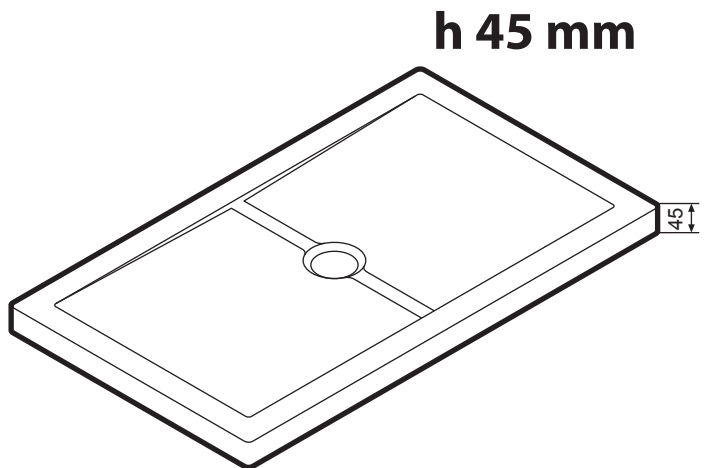

## NEW OLYMPIC

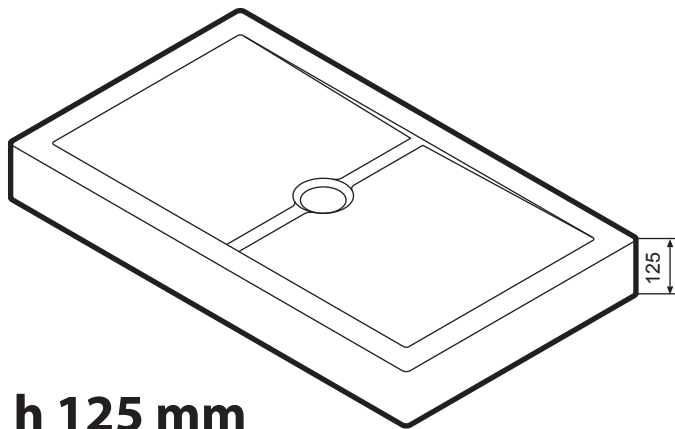
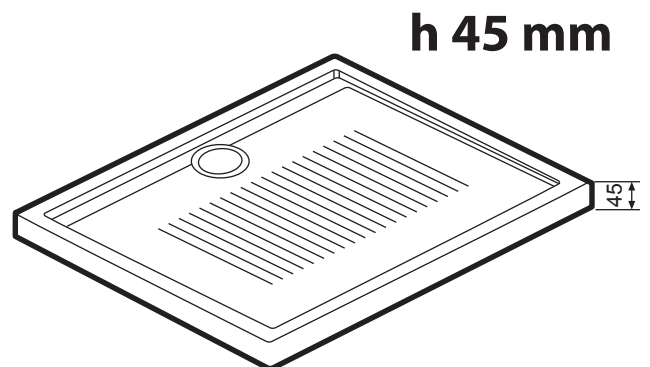
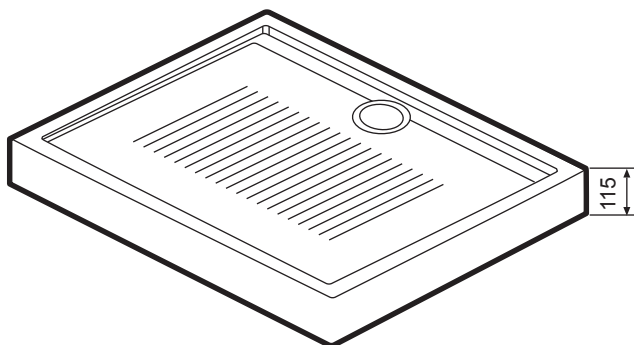

## OLYMPIC

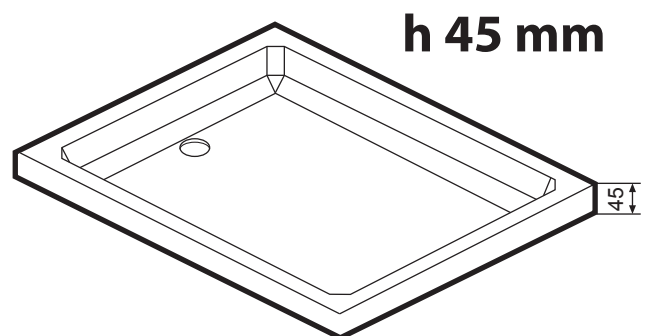
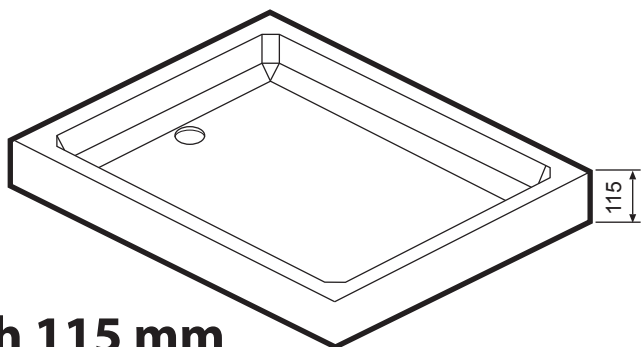

EN 14527

<p>Novellini Spa Via della Stazione, 2 - 46030 Romanore di Borgoforte Mantova Italy</p>
<p><b>12</b></p>
<p><b>EN 14527-CL 1</b></p>

<b>IT</b>	<p><b>EN14527Annex B :</b> Quando bagnata, la superficie della maggioranza dei piatti doccia dà un aumento nel potenziale scivolamento. Ciò è in particolare vero quando si utilizzano sapone, shampoo, olio da bagno, ecc. è importante che i progettisti, gli installatori e gli utilizzatori ne siano consapevoli</p>
<b>FR</b>	<p><b>EN14527Annexe B :</b> Une perte partielle d'adhérence en usage normal dans une salle de bains, est un phénomène naturel, propre même à la plupart des surfaces de receveurs de douche et peut, à ce titre, occasionner un risque potentiel de glissade. Cela d'autant plus que dans un contexte humide donc, mais avec de surcroît, l'utilisation de produits tel que : savon, huile de bain, shampoing etc.. . Il est important que les concepteurs, installateurs et utilisateurs en soient conscients.</p>
<b>EN</b>	<p><b>EN14527Annex B :</b> When wet, the surface of the majority of the shower trays is more slippery with a consequent increase of the slipping possibilities. This happens mainly because of soap and shampoo foam, bath oil etc. Designers, installers and end users <b>MUST</b> be aware of this</p>
<b>ES</b>	<p><b>EN14527Anexo B :</b> Cuando se moja, la superficie de la mayoría de los platos de ducha aumenta el riesgo potencial de resbalar, de forma particular cuando se utiliza jabón, shampoo, aceites de baño, etc. Es importante que las personas que realizan los proyectos, así como los instaladores y usuarios, sean conscientes de ello.</p>
<b>DE</b>	<p><b>EN14527Anhang B :</b> Auf der Mehrzahl der Duschwannen erhöht sich bei nasser Oberfläche das Potential an möglicher Verrutschgefahr. Schlupf. Dies gilt insbesondere bei der Verwendung von Seife, Shampoo, Badeöl, usw.. Es ist wichtig dass Planer, Installateure und Anwender sich dessen bewusst sind.</p>

IT - INDICE	
OLYMPIC PLUS h 125 mm, NEW OLYMPIC h115 mm, OLYMPIC h 115 mm	5
<b>Caratteristiche tecniche</b> - OLYMPIC PLUS h 125 mm	6
<b>Caratteristiche tecniche</b> - NEW OLYMPIC h 115 mm	7
<b>Caratteristiche tecniche</b> - OLYMPIC h 115 mm	8
<b>Installazione piatto</b> - OLYMPIC PLUS h 125 mm, NEW OLYMPIC h 115 mm	9
OLYMPIC PLUS h 45 mm, NEW OLYMPIC h 45 mm, OLYMPIC h 45 mm	12
<b>Caratteristiche tecniche</b> - OLYMPIC PLUS h 45 mm	13
<b>Caratteristiche tecniche</b> - NEW OLYMPIC h 45 mm	14
<b>Caratteristiche tecniche</b> - OLYMPIC h 45 mm	15
<b>Installazione piatto</b> - OLYMPIC PLUS h 45 mm, NEW OLYMPIC h 45 mm	16

FR - TABLE DES MATIERES	
OLYMPIC PLUS h 125 mm, NEW OLYMPIC h115 mm, OLYMPIC h 115 mm	5
<b>Caracteristiques techniques</b> - OLYMPIC PLUS h 125 mm	6
<b>Caracteristiques techniques</b> - NEW OLYMPIC h 115 mm	7
<b>Caracteristiques techniques</b> - OLYMPIC h 115 mm	8
<b>Installation receveur de douche</b> - OLYMPIC PLUS h 125 mm, NEW OLYMPIC h 115 mm	9
OLYMPIC PLUS h 45 mm, NEW OLYMPIC h 45 mm, OLYMPIC h 45 mm	12
<b>Caracteristiques techniques</b> - OLYMPIC PLUS h 45 mm	13
<b>Caracteristiques techniques</b> - NEW OLYMPIC h 45 mm	14
<b>Caracteristiques techniques</b> - OLYMPIC h 45 mm	15
<b>Installation receveur de douche</b> - OLYMPIC PLUS h 45 mm, NEW OLYMPIC h 45 mm	16

EN - CONTENTS	
OLYMPIC PLUS h 125 mm, NEW OLYMPIC h115 mm, OLYMPIC h 115 mm	5
<b>Technical specifications</b> - OLYMPIC PLUS h 125 mm	6
<b>Technical specifications</b> - NEW OLYMPIC h 115 mm	7
<b>Technical specifications</b> - OLYMPIC h 115 mm	8
<b>Tray installation</b> - OLYMPIC PLUS h 125 mm, NEW OLYMPIC h 115 mm	9
OLYMPIC PLUS h 45 mm, NEW OLYMPIC h 45 mm, OLYMPIC h 45 mm	12
<b>Technical specifications</b> - OLYMPIC PLUS h 45 mm	13
<b>Technical specifications</b> - NEW OLYMPIC h 45 mm	14
<b>Technical specifications</b> - OLYMPIC h 45 mm	15
<b>Tray installation</b> - OLYMPIC PLUS h 45 mm, NEW OLYMPIC h 45 mm	16

ES - ÍNDICE	
OLYMPIC PLUS h 125 mm, NEW OLYMPIC h115 mm, OLYMPIC h 115 mm	5
<b>Características técnicas</b> - OLYMPIC PLUS h 125 mm	6
<b>Características técnicas</b> - NEW OLYMPIC h 115 mm	7
<b>Características técnicas</b> - OLYMPIC h 115 mm	8
<b>Instalación del plato de ducha</b> - OLYMPIC PLUS h 125 mm, NEW OLYMPIC h 115 mm	9
OLYMPIC PLUS h 45 mm, NEW OLYMPIC h 45 mm, OLYMPIC h 45 mm	12
<b>Características técnicas</b> - OLYMPIC PLUS h 45 mm	13
<b>Características técnicas</b> - NEW OLYMPIC h 45 mm	14
<b>Características técnicas</b> - OLYMPIC h 45 mm	15
<b>Instalación del plato de ducha</b> - OLYMPIC PLUS h 45 mm, NEW OLYMPIC h 45 mm	16

DE - INHALTSVERZEICHNIS	
OLYMPIC PLUS h 125 mm, NEW OLYMPIC h115 mm, OLYMPIC h 115 mm	5
<b>Technische eigenschaften</b> - OLYMPIC PLUS h 125 mm	6
<b>Technische eigenschaften</b> - NEW OLYMPIC h 115 mm	7
<b>Technische eigenschaften</b> - OLYMPIC h 115 mm	8
<b>Montage Brausetasse</b> - OLYMPIC PLUS h 125 mm, NEW OLYMPIC h 115 mm	9
OLYMPIC PLUS h 45 mm, NEW OLYMPIC h 45 mm, OLYMPIC h 45 mm	12
<b>Technische eigenschaften</b> - OLYMPIC PLUS h 45 mm	13
<b>Technische eigenschaften</b> - NEW OLYMPIC h 45 mm	14
<b>Technische eigenschaften</b> - OLYMPIC h 45 mm	15
<b>Montage Brausetasse</b> - OLYMPIC PLUS h 45 mm, NEW OLYMPIC h 45 mm	16

IT CARATTERISTICHE TECNICHE  
FR CARACTERISTIQUES TECHNIQUES  
EN TECHNICAL SPECIFICATIONS  
ES CARACTERÍSTICAS TÉCNICAS  
DE TECHNISCHE EIGENSCHAFTEN

## OLYMPIC PLUS

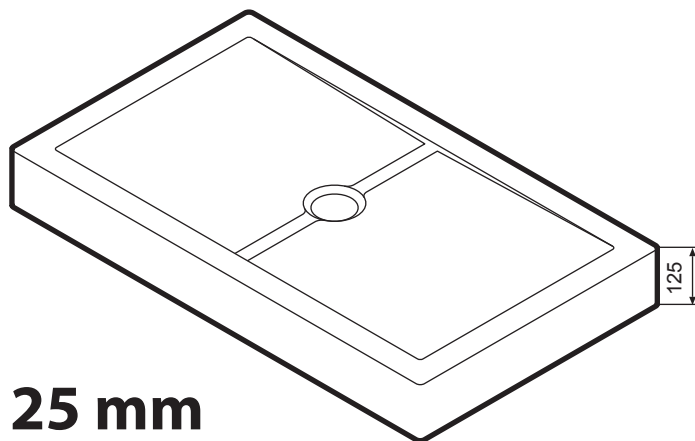

**h 125 mm**

- 180x75
- 170x90
- 170x80
- 170x75
- 170x70
- 160x90
- 160x80
- 160x75
- 160x70
- 150x75
- 150x70
- 140x100
- 140x90
- 140x80
- 140x75
- 140x70
- 120x100
- 120x90
- 120x80
- 120x70

## NEW OLYMPIC

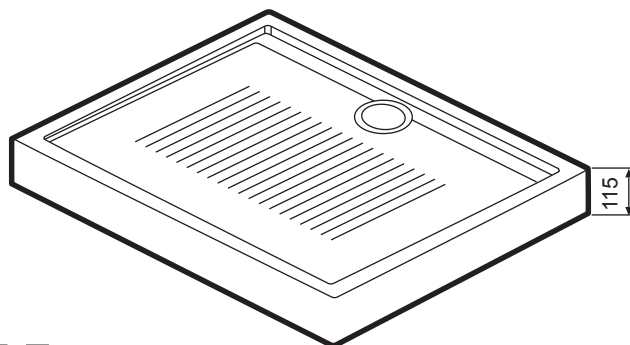

**h 115 mm**

- 100x100
- 100x80
- 100x70
- 90x90
- 90x75
- 90x70
- 80x80

## OLYMPIC

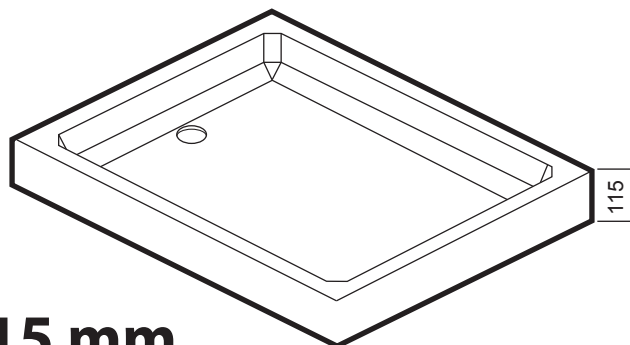

**h 115 mm**

- 120x80
- 100x100
- 100x80
- 90x90
- 90x72
- 80x80
- 75x75



EN 14527

# OLYMPIC PLUS h125 mm

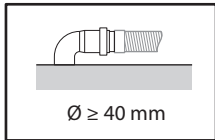

**C** IT Area consigliata per lo scarico a pavimento  
**FR** Zone conseillée pour le vidage des eaux au sol  
**EN** Recommended space for floor-mounted drain  
**ES** Espacio necesario para desagüe a suelo  
**DE** Empfohlener Bereich für den Abfluß

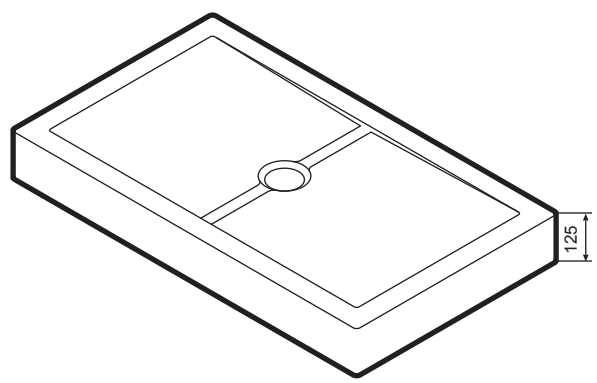
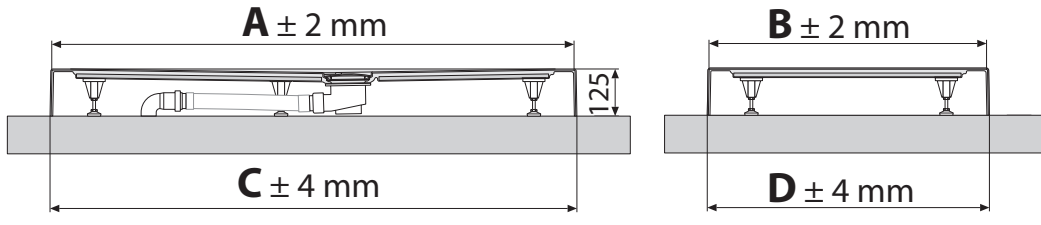
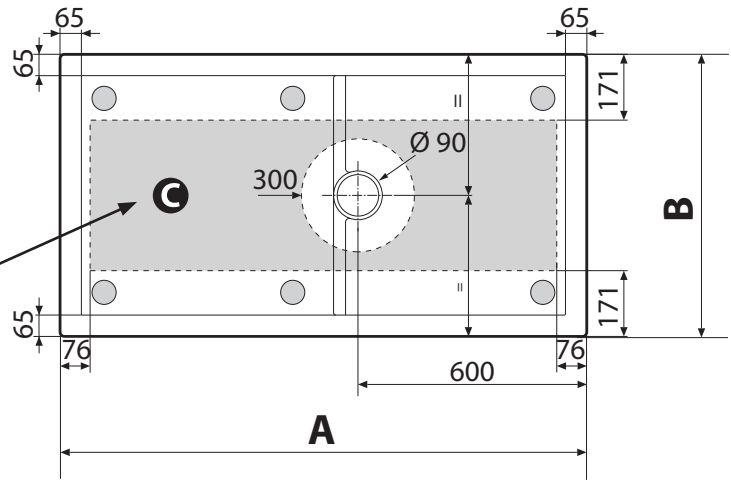

Olympic Plus	A	B	C	D
<b>120 x 70</b>	1194	692	1200	698
<b>120 x 80</b>	1194	792	1200	798
<b>120 x 90</b>	1194	892	1200	898
<b>120 x 100</b>	1194	992	1200	998
<b>140 x 70</b>	1392	692	1398	698
<b>140 x 75</b>	1392	742	1398	748
<b>140 x 80</b>	1392	792	1398	798
<b>140 x 90</b>	1392	892	1398	898
<b>140 x 100</b>	1392	992	1398	998
<b>150 x 70</b>	1492	692	1498	698
<b>150 x 75</b>	1492	742	1498	748
<b>160 x 70</b>	1592	692	1598	698
<b>160 x 75</b>	1592	742	1598	748
<b>160 x 80</b>	1592	792	1598	798
<b>160 x 90</b>	1592	892	1598	898
<b>170 x 70</b>	1692	692	1698	698
<b>170 x 75</b>	1692	742	1698	748
<b>170 x 80</b>	1692	792	1698	798
<b>170 x 90</b>	1692	892	1698	898
<b>180 x 75</b>	1792	742	1798	748

# NEW OLYMPIC h115 mm

- C** IT Area consigliata per lo scarico a pavimento  
**FR** Zone conseillée pour le vidage des eaux au sol  
**EN** Recommended space for floor-mounted drain  
**ES** Espacio necesario para desagüe a suelo  
**DE** Empfohlener Bereich für den Abfluß

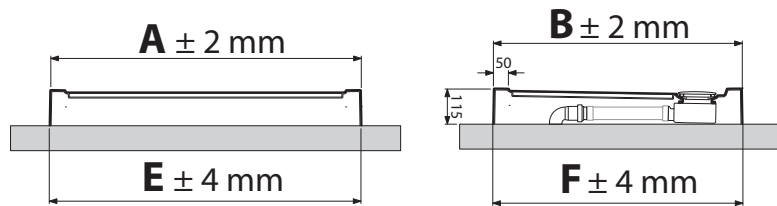
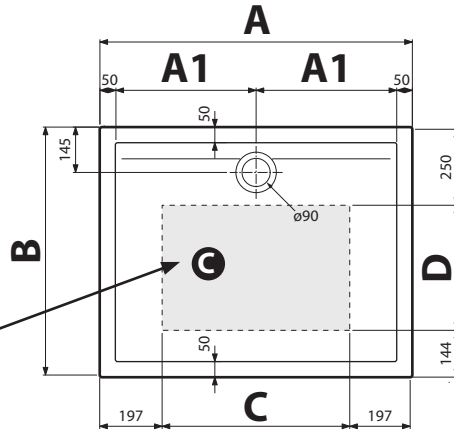

New Olympic	A	A1	B	C	D	E x F
<b>80x80</b>	794	347	794	400	400	798x798
<b>90x70</b>	894	397	694	500	300	898x698
<b>90x75</b>	894	397	744	500	350	898x748
<b>90x90</b>	894	397	894	500	500	898x898
<b>100x70</b>	994	447	694	600	300	998x698
<b>100x80</b>	994	447	794	600	400	998x798
<b>100x100</b>	994	447	994	600	600	998x998

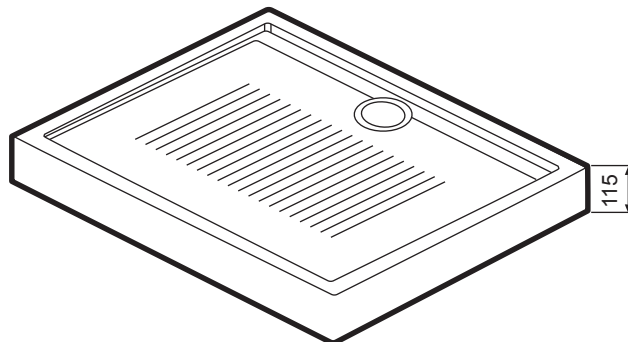

# OLYMPIC h115 mm

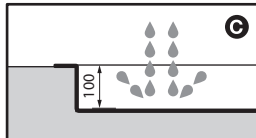
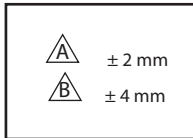
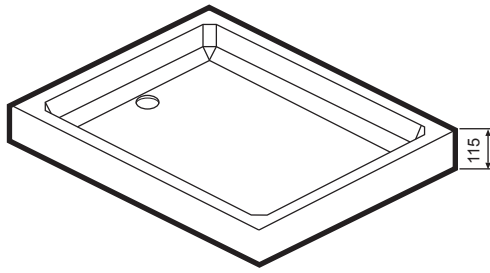

**C** IT Area consigliata per lo scarico a pavimento  
 FR Zone conseillée pour le vidage des eaux au sol  
 EN Recommended space for floor-mounted drain  
 ES Espacio necesario para desagüe a suelo  
 DE Empfohlener Bereich für den Abfluß

**Olympic 120x80 - h 11,5 cm**

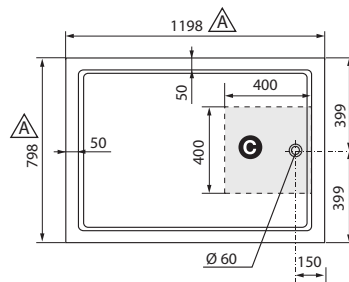

**Olympic 100x100 - h 11,5 cm**

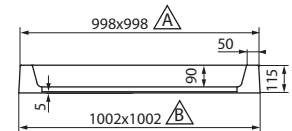
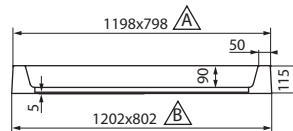
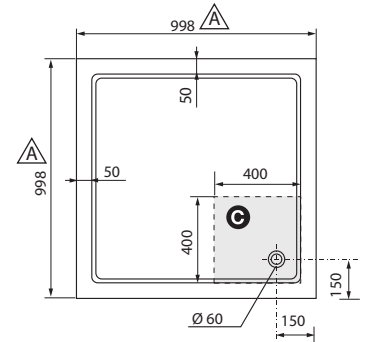

**Olympic 100x80 - h 11,5 cm**

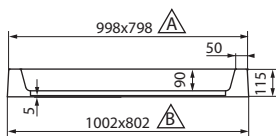
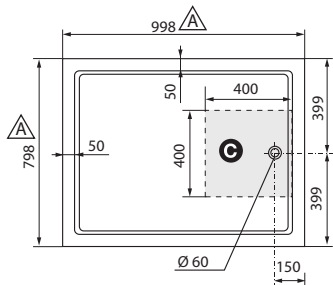

**Olympic 90x90 - h 11,5 cm**

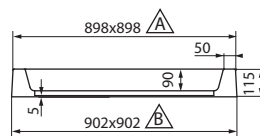
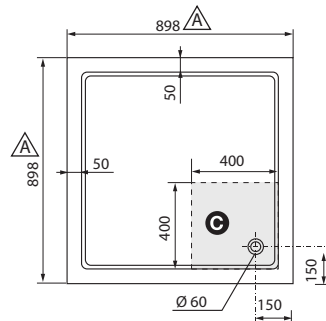

**Olympic 90x72 - h 11,5 cm**

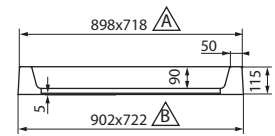
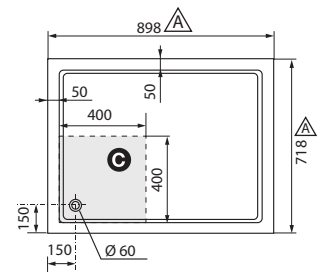

**Olympic 80x80 - h 11,5 cm**

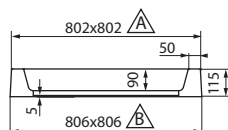
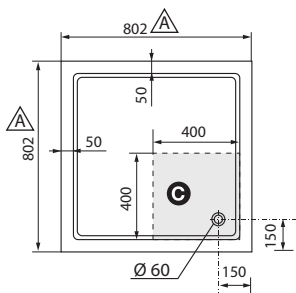

**Olympic 75x75 - h 11,5 cm**

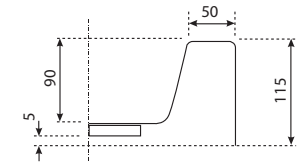
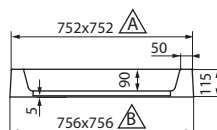
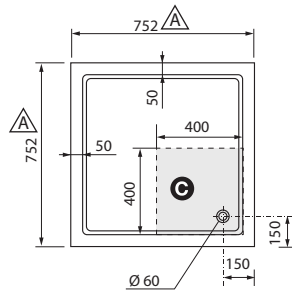



**IT** Installazione piatto  
**FR** Installation receveur de douche  
**EN** Tray installation  
**ES** Instalación del plato de ducha  
**DE** Montage Brausetasse

**• OLYMPIC PLUS**  
 h 125 mm  
**• NEW OLYMPIC**  
 h 115 mm

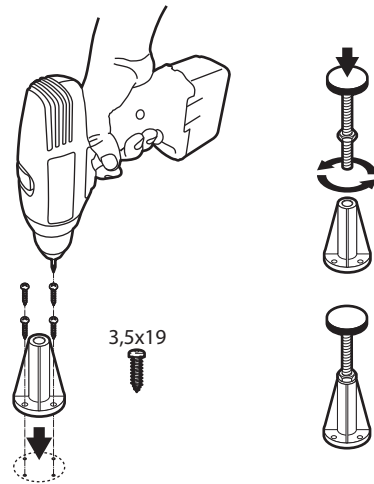
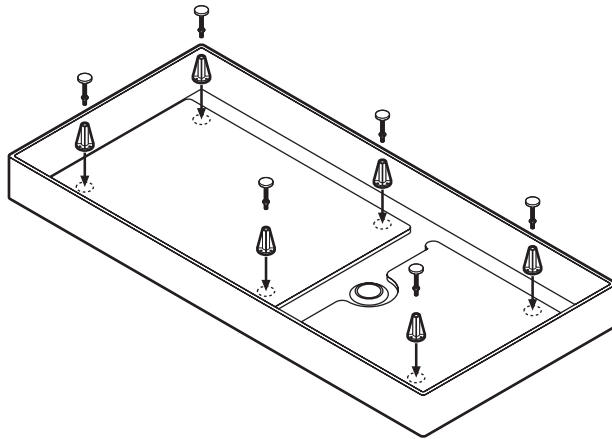

3,5x19

**2**

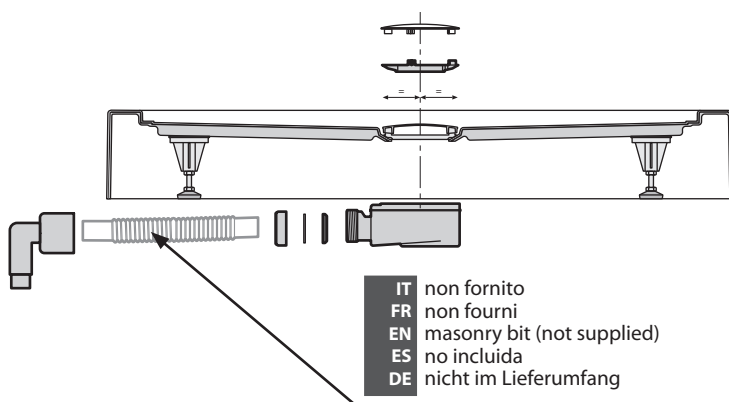

**IT** non fornito  
**FR** non fourni  
**EN** masonry bit (not supplied)  
**ES** no incluida  
**DE** nicht im Lieferumfang

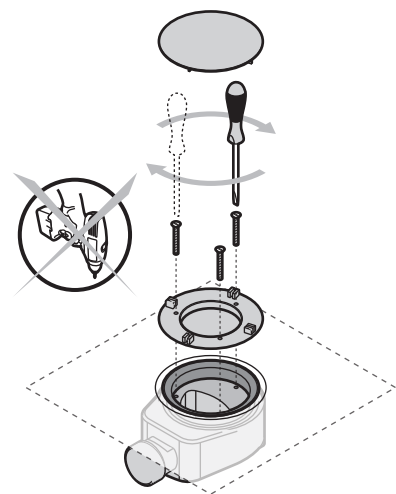

# 3

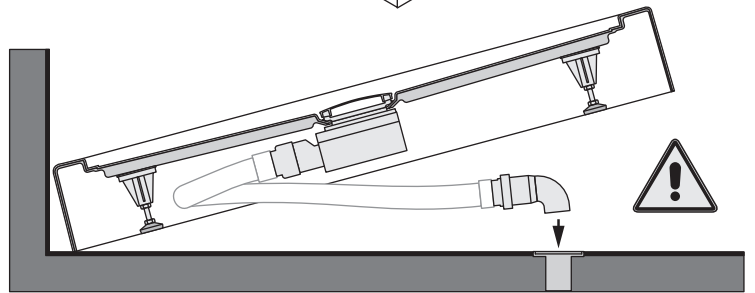
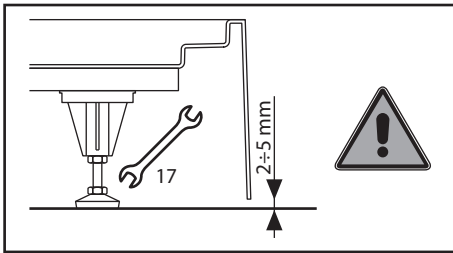
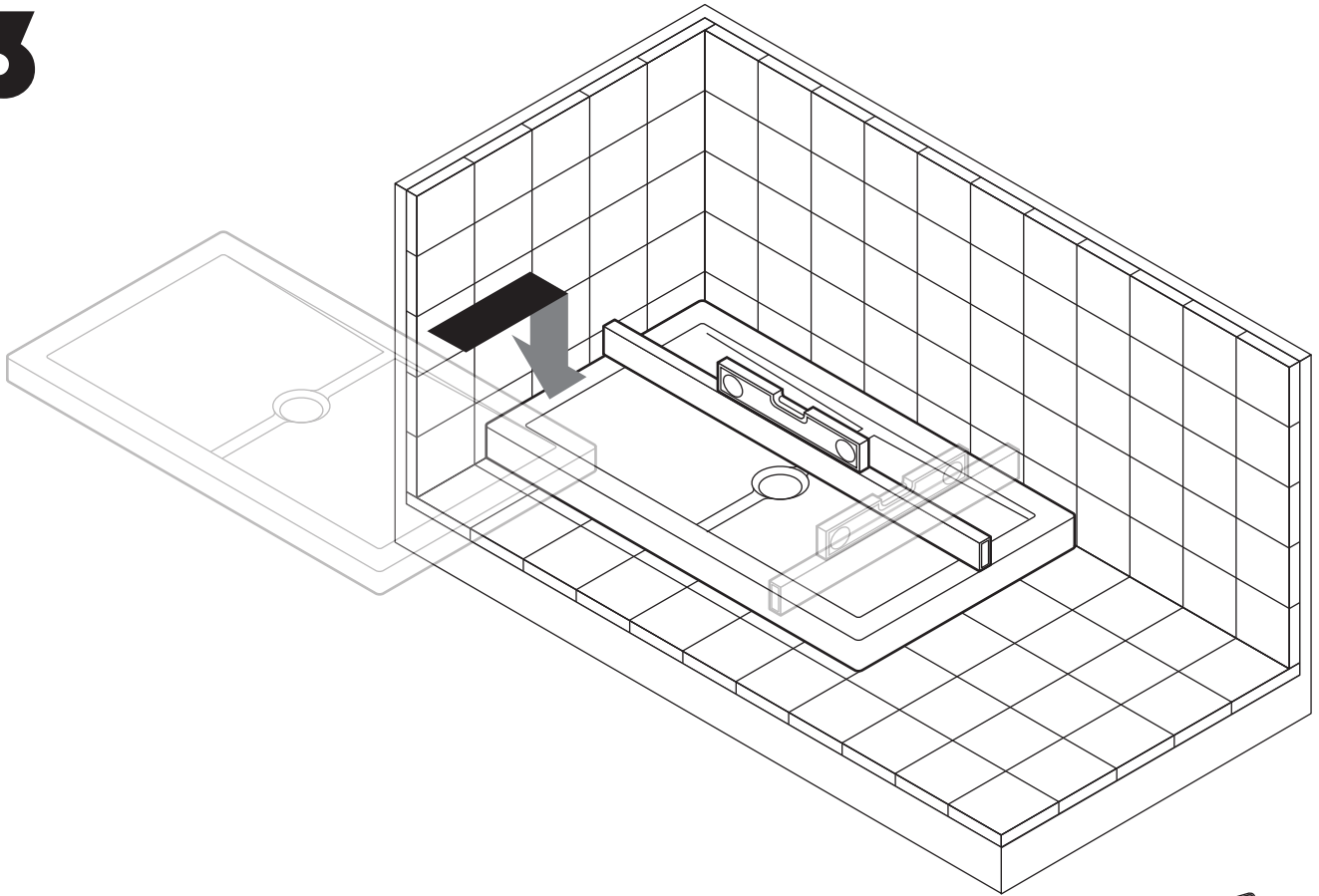

# 4

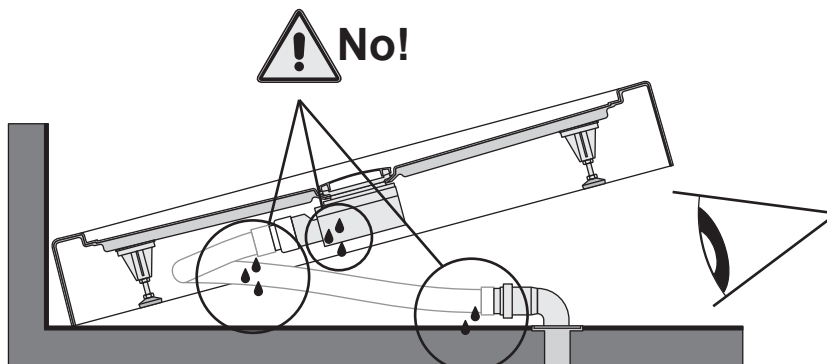
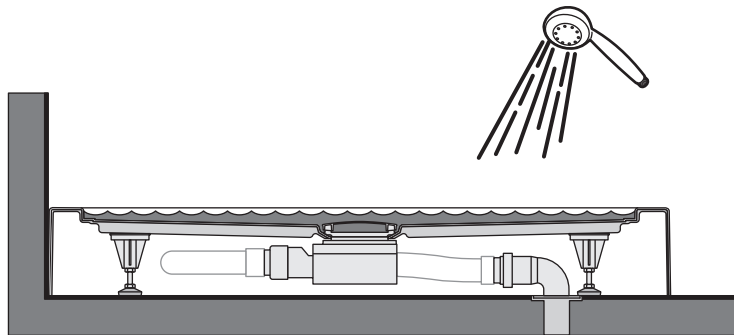

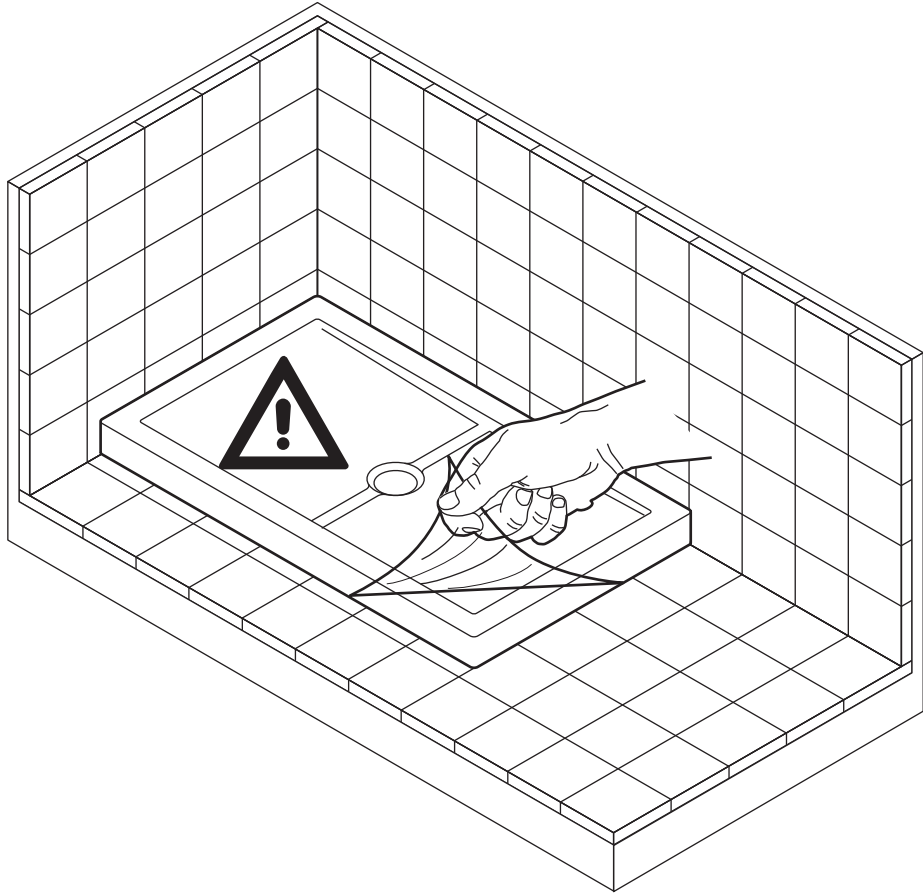

**5**

IT Optional  
FR Option  
EN Optional  
ES Opcional  
DE Optional Profile

IT Non acetico  
FR Non acétique  
EN Acetic-acid free  
ES No acético  
DE Essigsäurefrei

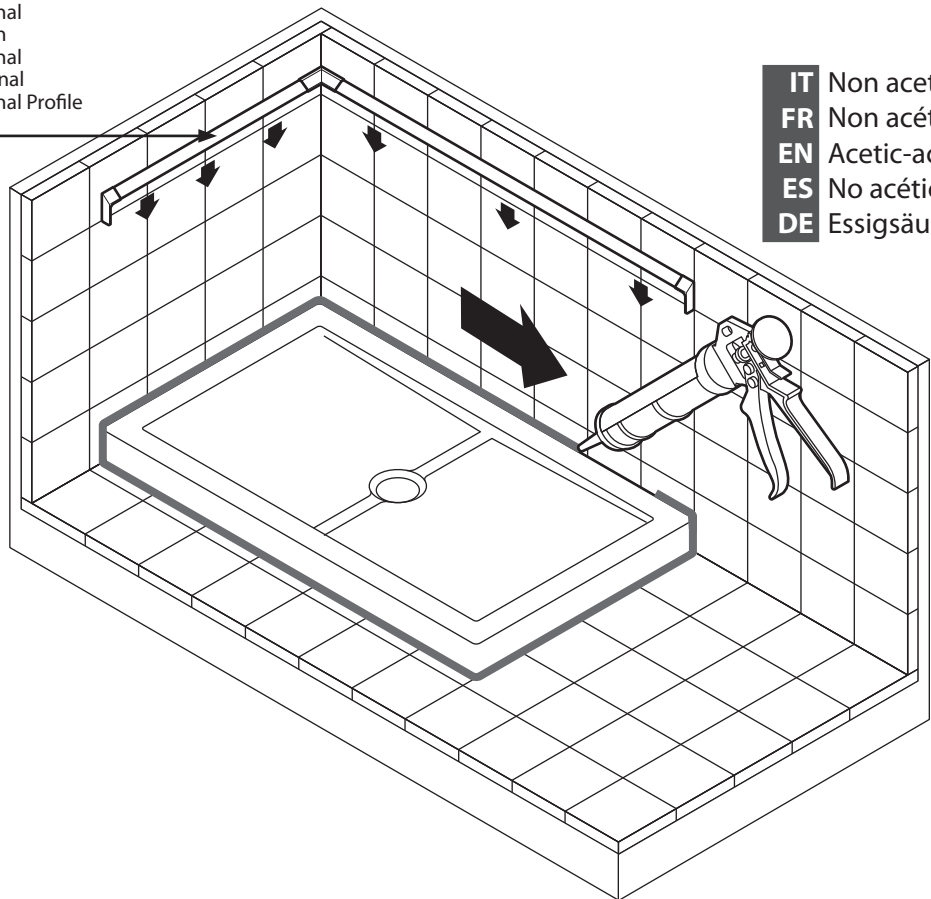
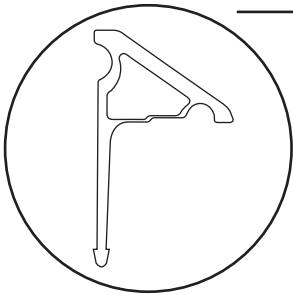

IT CARATTERISTICHE TECNICHE  
FR CARACTERISTIQUES TECHNIQUES  
EN TECHNICAL SPECIFICATIONS  
ES CARACTERÍSTICAS TÉCNICAS  
DE TECHNISCHE EIGENSCHAFTEN

## OLYMPIC PLUS

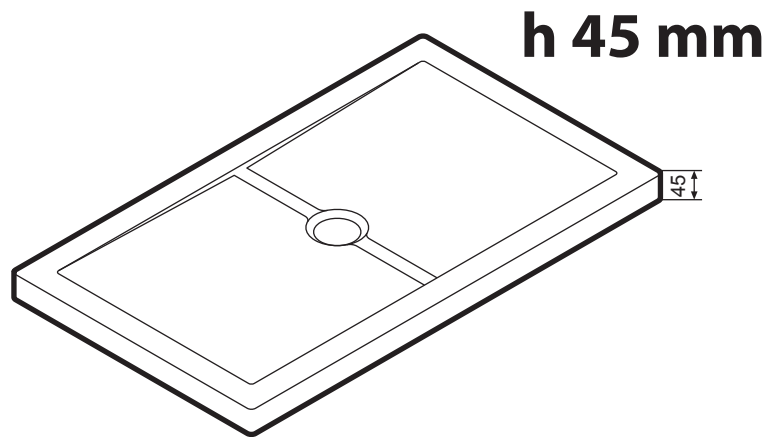

- 180x75
- 170x90
- 170x80
- 170x75
- 170x70
- 160x90
- 160x80
- 160x75
- 160x70
- 150x75
- 150x70
- 140x100
- 140x90
- 140x80
- 140x75
- 140x70
- 120x100
- 120x90
- 120x80
- 120x70

## NEW OLYMPIC

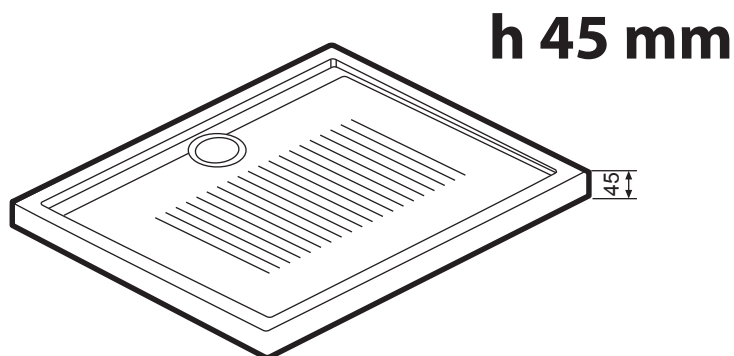

- 100x100
- 100x80
- 100x70
- 90x90
- 90x75
- 90x70
- 80x80

## OLYMPIC

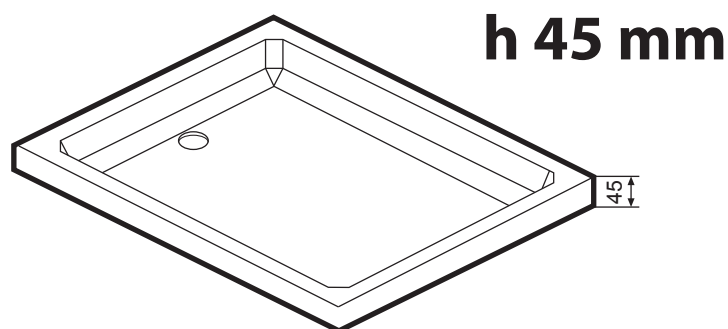

- 120x80
- 100x100
- 100x80
- 90x90
- 90x72
- 80x80
- 75x75



EN 14527

# OLYMPIC PLUS h 45 mm

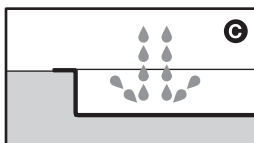
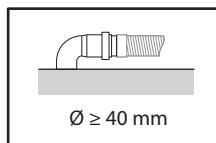

**C** IT Area minima da realizzare nel pavimento  
 FR Zone d'allocation minimum à faire au sol  
 EN Minimum space required in floor  
 ES Espacio mínimo necesario para desagüe a suelo  
 DE Mindeststeinbaufläche im Boden

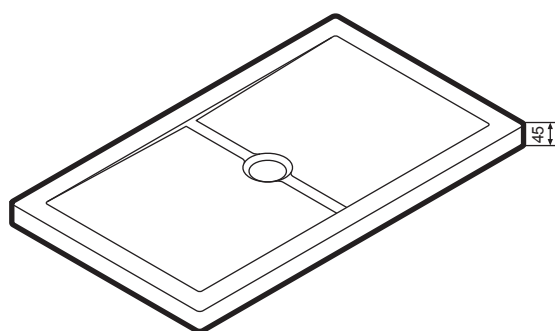
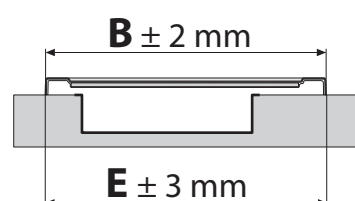
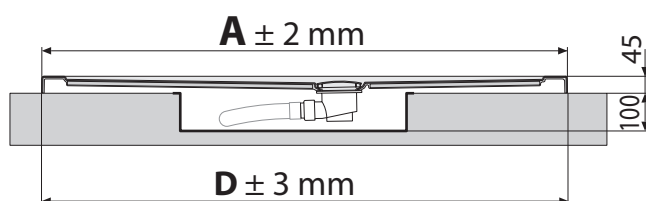
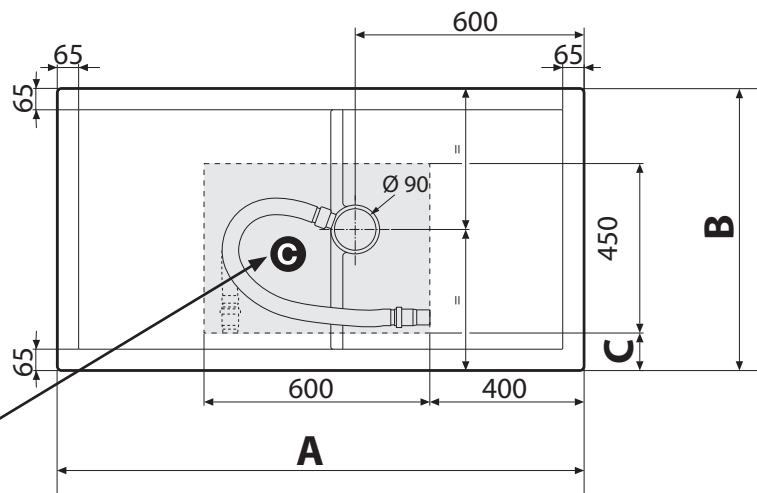

Olympic Plus	A	B	C	D	E
<b>120 x 70</b>	1194	692	75	1196	694
<b>120 x 80</b>	1194	792	125	1196	794
<b>120 x 90</b>	1194	892	175	1196	894
<b>120 x 100</b>	1194	992	225	1196	994
<b>140 x 70</b>	1392	692	75	1394	694
<b>140 x 75</b>	1392	742	100	1394	744
<b>140 x 80</b>	1392	792	125	1394	794
<b>140 x 90</b>	1392	892	175	1394	894
<b>140 x 100</b>	1392	992	225	1394	994
<b>150 x 70</b>	1492	692	75	1494	694
<b>150 x 75</b>	1492	742	100	1494	744
<b>160 x 70</b>	1592	692	75	1594	694
<b>160 x 75</b>	1592	742	100	1594	744
<b>160 x 80</b>	1592	792	125	1594	794
<b>160 x 90</b>	1592	892	175	1594	894
<b>170 x 70</b>	1692	692	75	1694	694
<b>170 x 75</b>	1692	742	100	1694	744
<b>170 x 80</b>	1692	792	125	1694	794
<b>170 x 90</b>	1692	892	175	1694	894
<b>180 x 75</b>	1792	742	100	1794	744

# NEW OLYMPIC h 45 mm

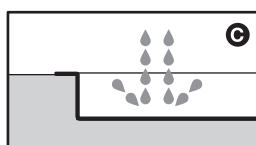
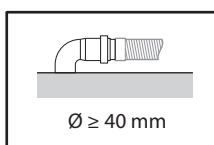
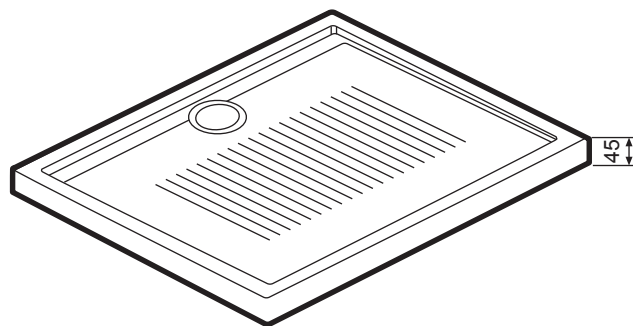

**C** IT Area minima da realizzare nel pavimento  
 FR Zone d'allocation minimum à faire au sol  
 EN Minimum space required in floor  
 ES Espacio mínimo necesario para desagüe a suelo  
 DE Mindesteinbaufäche im Boden

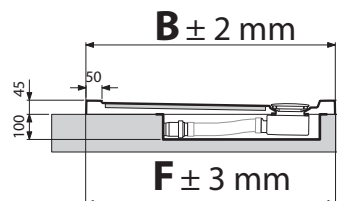
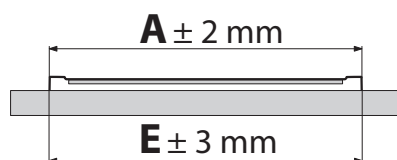
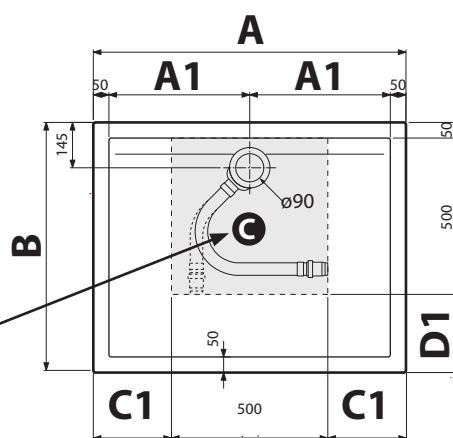

New Olympic	A	A1	B	C1	D1	E x F
<b>80x80</b>	794	347	794	147	244	796x796
<b>90x70</b>	894	397	694	197	144	896x696
<b>90x75</b>	894	397	744	197	194	896x746
<b>90x90</b>	894	397	894	197	344	896x896
<b>100x70</b>	994	447	694	247	144	996x696
<b>100x80</b>	994	447	794	247	244	996x796
<b>100x100</b>	994	447	994	247	444	996x996

# OLYMPIC h 45 mm

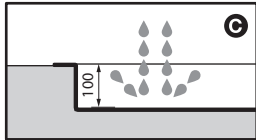
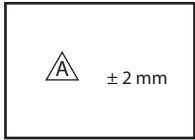
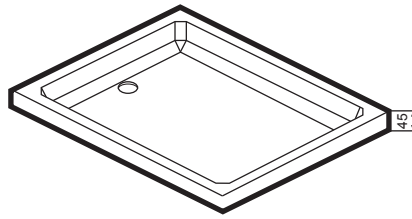

**C** IT Area minima da realizzare nel pavimento  
**FR** Zone d'allocation minimum à faire au sol  
**EN** Minimum space required in floor  
**ES** Espacio mínimo necesario para desagüe a suelo  
**DE** Mindesteinbaufäche im Boden

**Olympic 120x80 - h 4,5 cm**

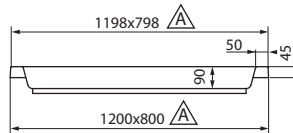
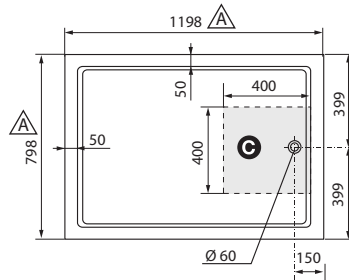

**Olympic 100x100 - h 4,5 cm**

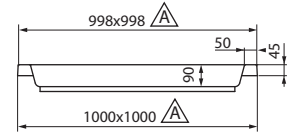
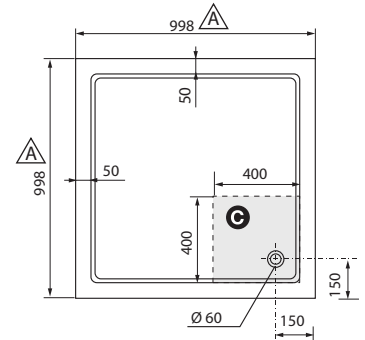

**Olympic 100x80 - h 4,5 cm**

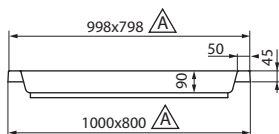
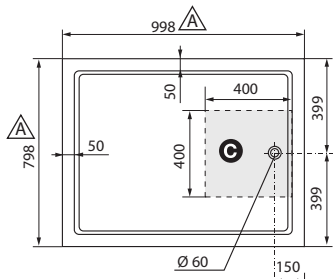

**Olympic 90x90 - h 4,5 cm**

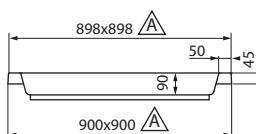
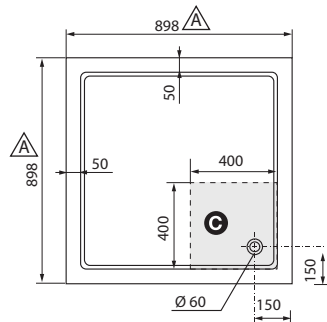

**Olympic 90x72 - h 4,5 cm**

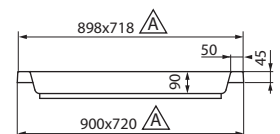
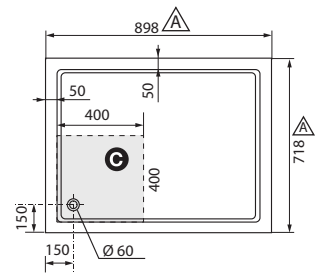

**Olympic 80x80 - h 4,5 cm**

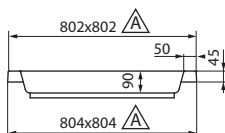
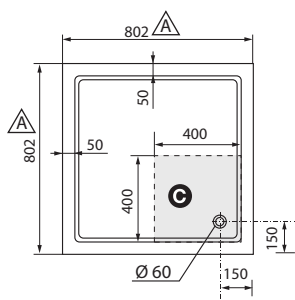

**Olympic 75x75 - h 4,5 cm**

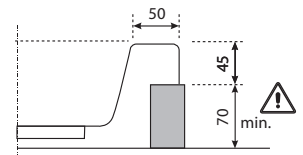
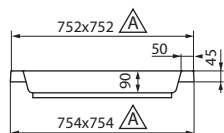
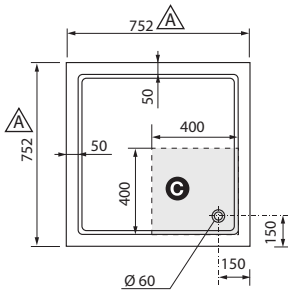

**IT** Installazione piatto  
**FR** Installation receveur de douche  
**EN** Tray installation  
**ES** Instalación del plato de ducha  
**DE** Montage Brausetasse

**• OLYMPIC PLUS**  
 h 45 mm  
**• NEW OLYMPIC**  
 h 45 mm

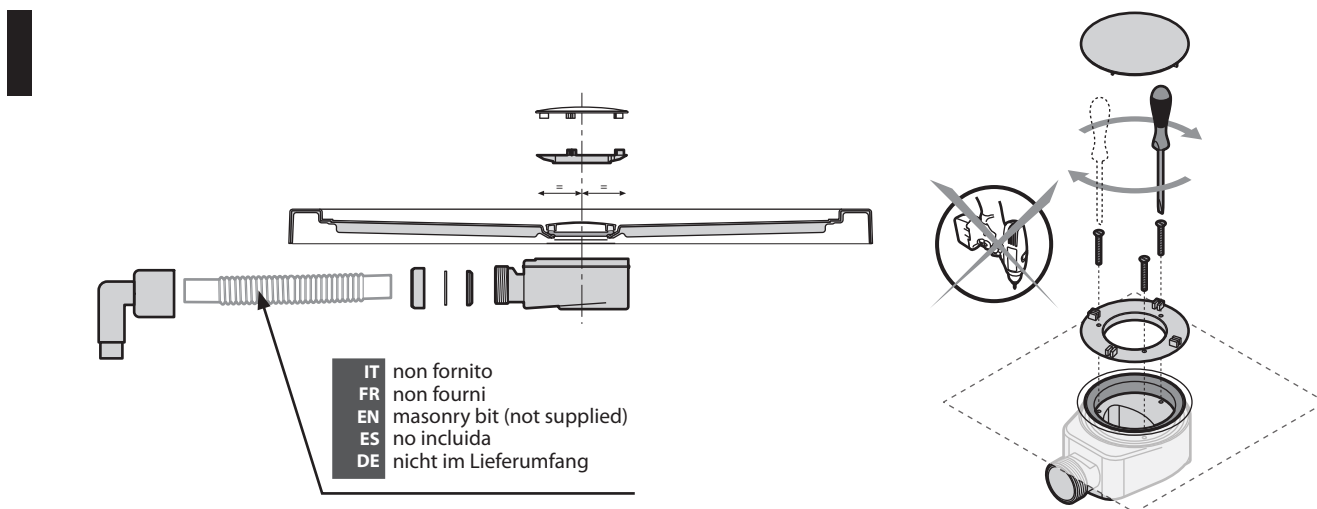

**2**

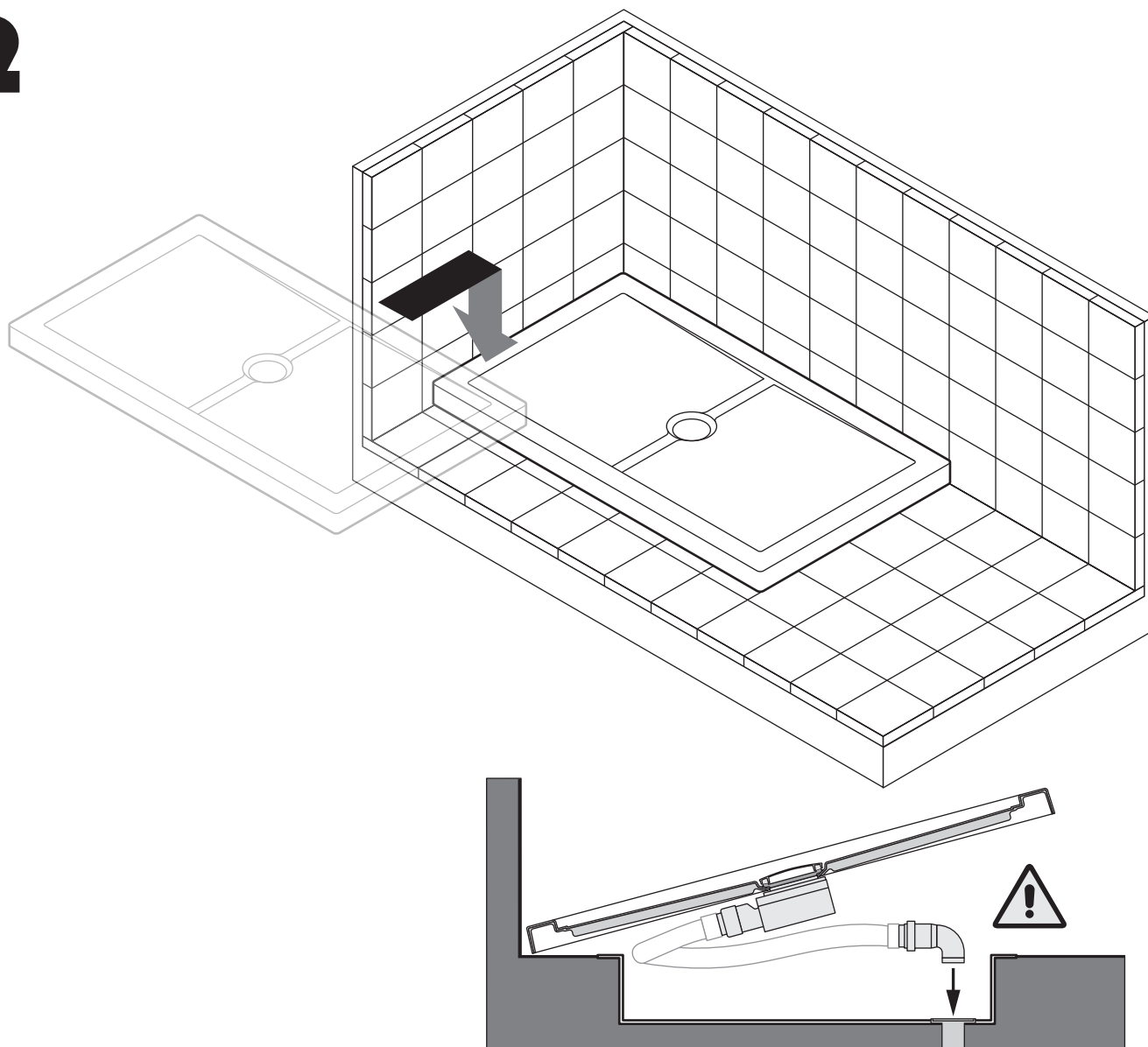



# 3

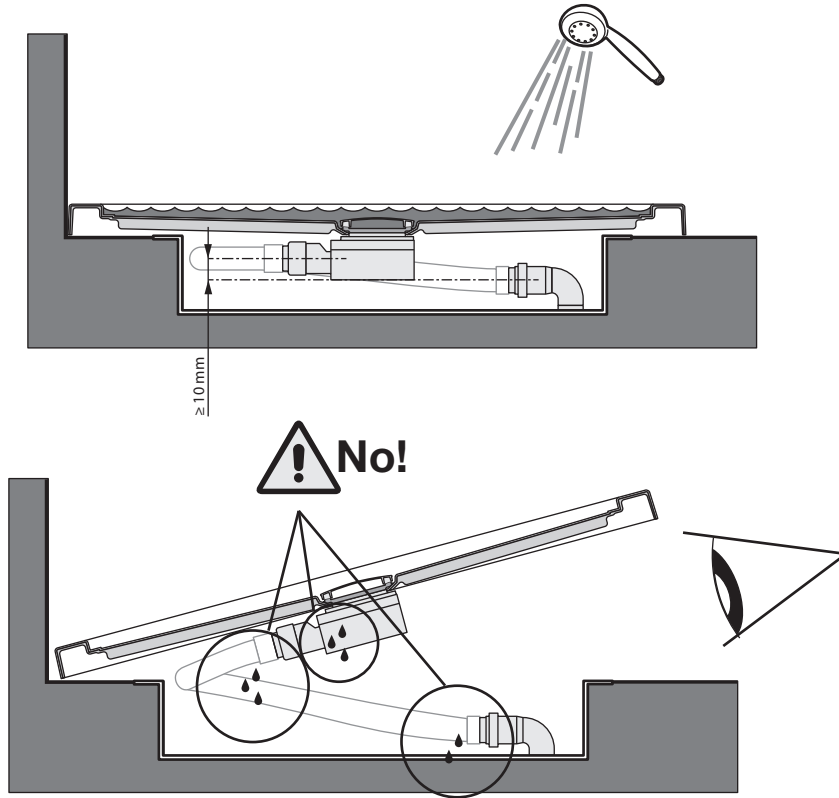

# 4

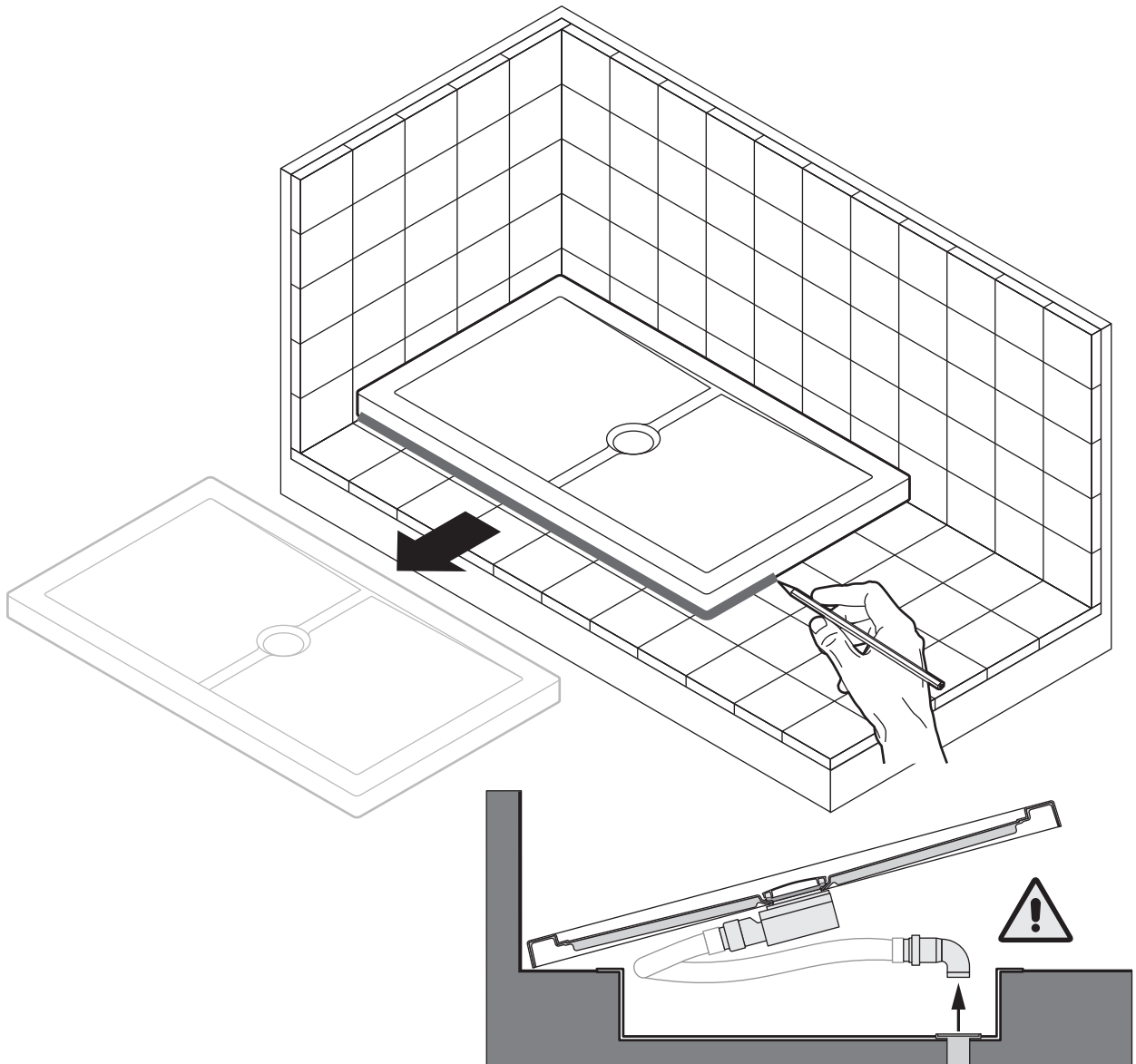

# 5

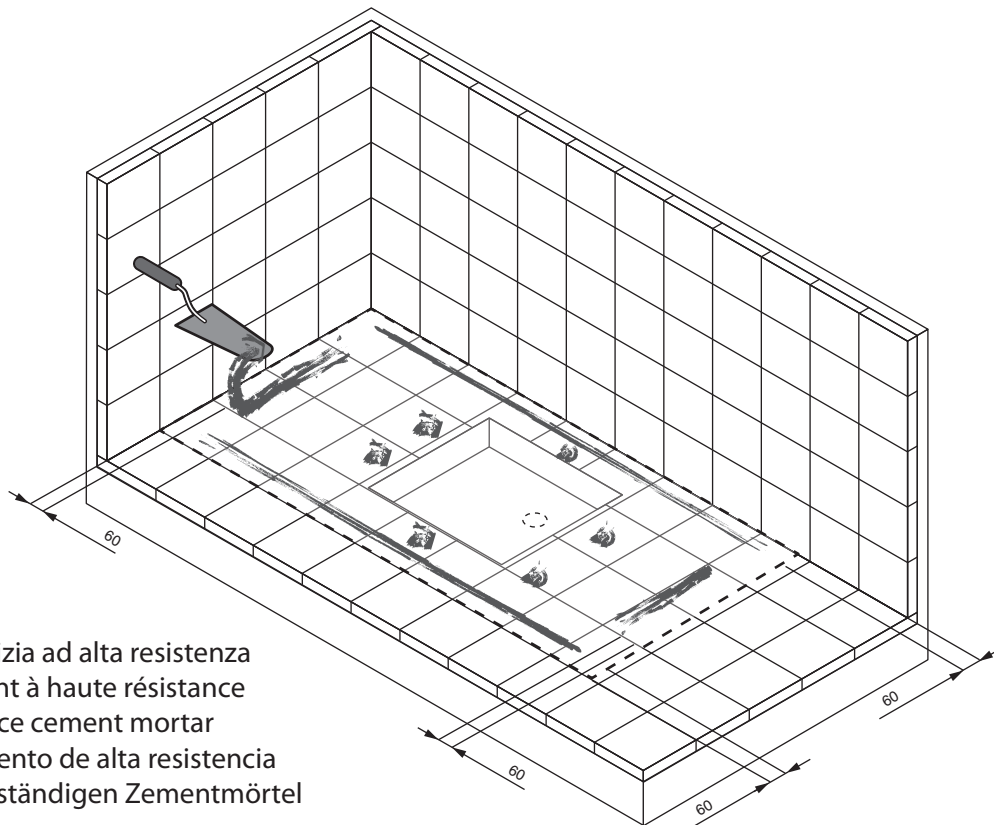

- IT** Utilizzare malta cementizia ad alta resistenza
- FR** Utiliser mortier en ciment à haute résistance
- EN** Please use high resistance cement mortar
- ES** Utilizar mortero de cemento de alta resistencia
- DE** Verwenden Sie hoch beständigen Zementmörtel

# 6

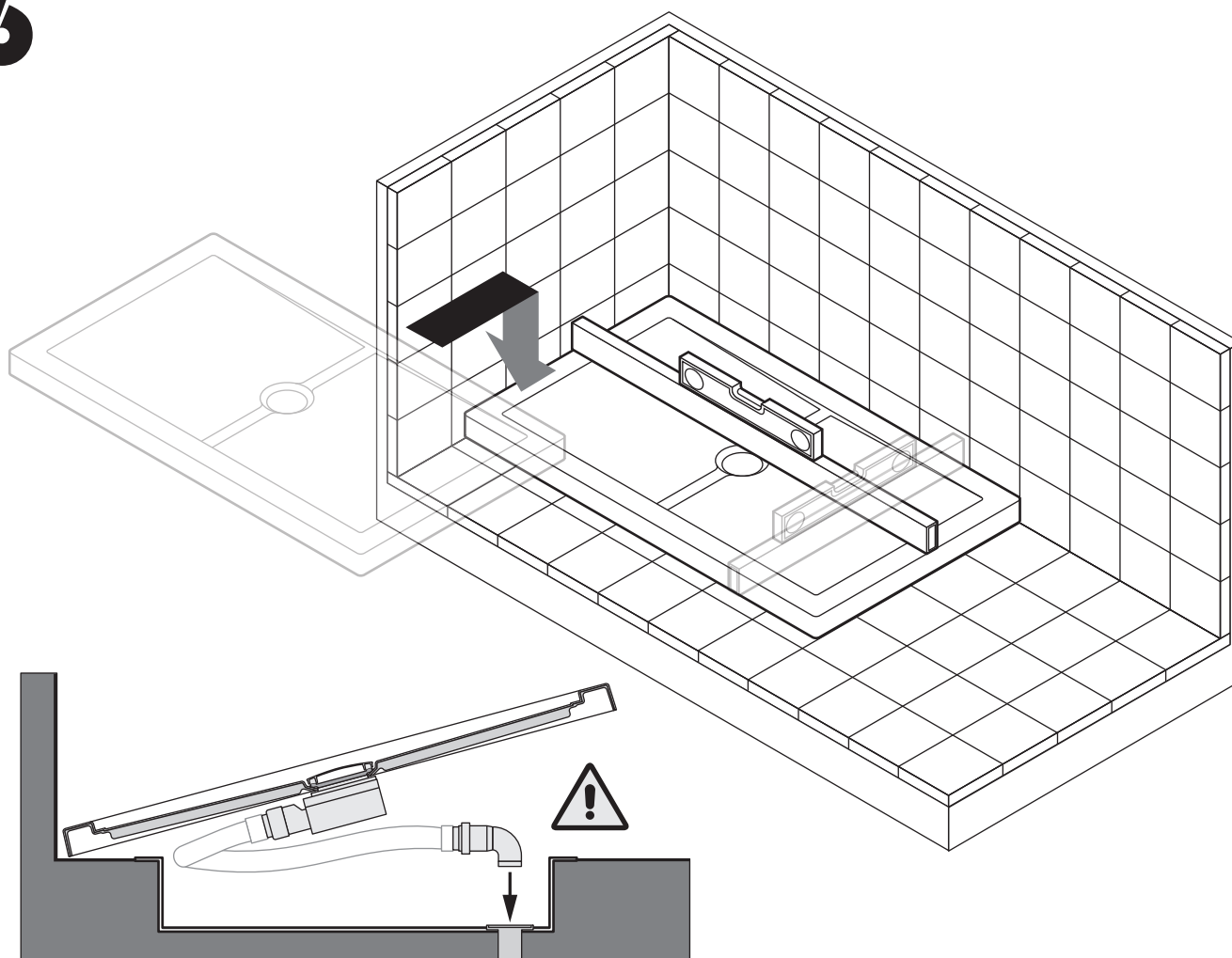

# 7

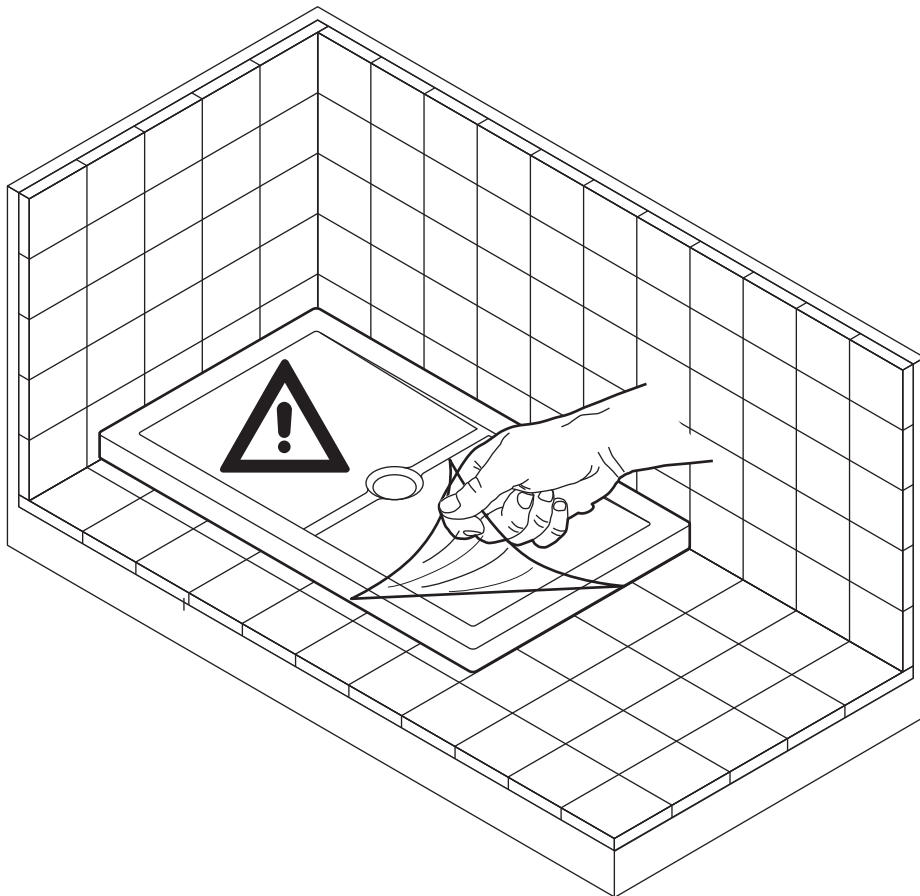
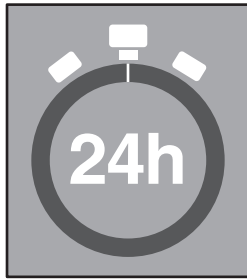
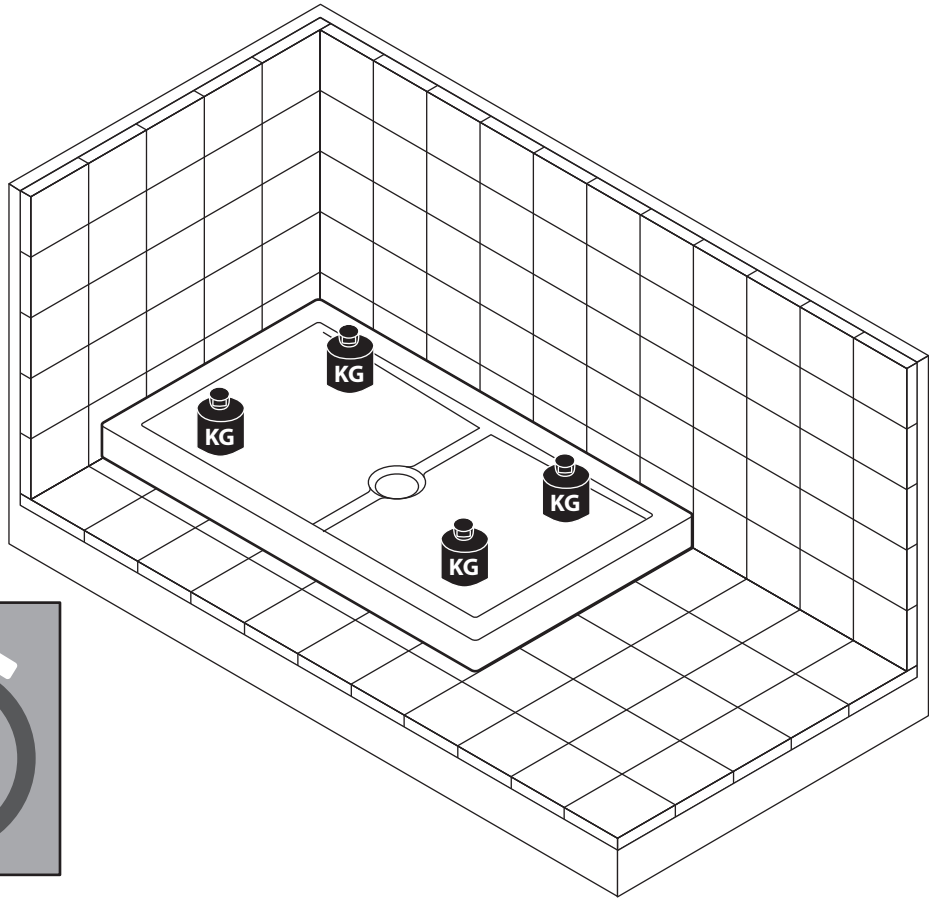

# 8

IT Non acetico  
FR Non acétique  
EN Acetic-acid free  
ES No acético  
DE Essigsäurefrei

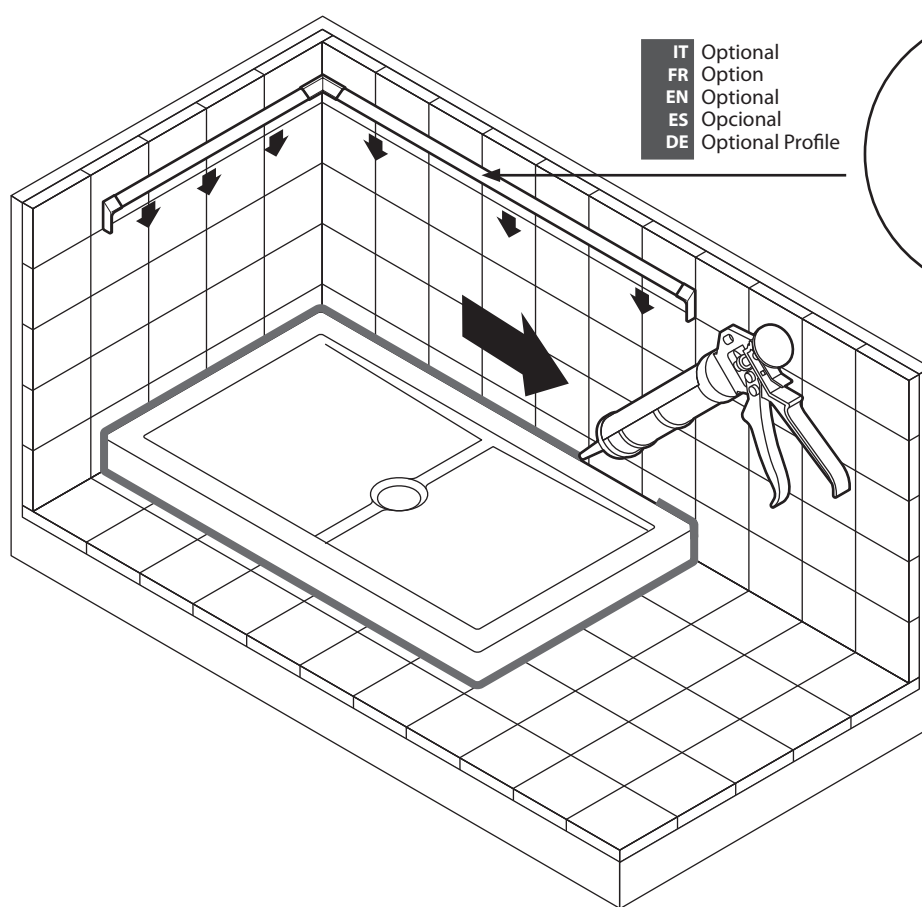

IT Optional  
FR Option  
EN Optional  
ES Opcional  
DE Optional Profile

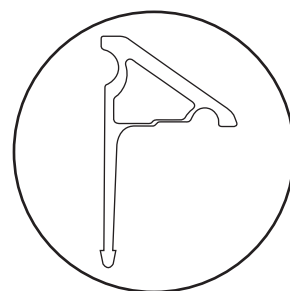

#### IT - GARANZIA

Il costruttore garantisce i propri prodotti contro vizi di fabbricazione e di materiale solo se riscontrati da personale autorizzato dall'azienda per un periodo di 24 mesi dalla data di acquisto comprovata dalla ricevuta o dallo scontrino fiscale. La garanzia consiste nella riparazione e/o sostituzione delle parti che verranno ritenute difettose; è esclusa la sostituzione completa del prodotto. Il prodotto deve essere installato a regola d'arte da personale specializzato; eventuali difetti superficiali e/o di finitura devono essere segnalati prima dell'installazione definitiva. Si consiglia la verifica del prodotto prima di installarlo, ed un controllo funzionale preliminare.

• **Pulizia della superficie acrilica e degli accessori** Per la normale pulizia delle superfici acriliche usare detergenti liquidi con una spugna o panno morbidi. Per evitare il formarsi di tracce di calcare è ideale asciugare le superfici acriliche dopo l'uso, con una pelle di daino o panno in microfibra, che pulisce a fondo senza lasciare residui. Eventuali tracce di calcare si tolgono utilizzando detergenti anticalcare specifici. Per ridare lucentezza alle superfici acriliche utilizzare un normale "Polish" usato anche per lucidare la carrozzeria delle auto.

⚠ **NON USARE ASSOLUTAMENTE DETERSIVI ABRASIVI, ALCOOL, SOSTANZE A BASE DI ALCOOL, ACETONE O ALTRI SOLVENTI.**

#### FR - GARANTIE

Le fabricant garantit ses produits contre tout vice de fabrication et de matériau uniquement sur constatation de personnes agréées par la société, pendant une période de 24 mois à compter de la date d'achat, reçu ou ticket de caisse faisant foi. La garantie couvre la réparation et/ou le remplacement des pièces retenues défectueuses. La garantie exclut le remplacement total du produit. Le produit doit être installé dans les règles de l'art par des techniciens spécialisés; communiquer tout défaut de surface et/ou de finition avant l'installation définitive. Il est recommandé de bien examiner le produit avant de le monter et d'effectuer un contrôle de fonctionnement préliminaire.

• **Nettoyage des surfaces acryliques et des accessoires** – Dans des conditions normales, nettoyer les surfaces acryliques avec des produits détergents liquides non abrasifs, en utilisant une éponge ou un chiffon. Pour empêcher la formation de dépôts de calcaire, utiliser une peau de chamois ou un chiffon en microfibre, lesquels essuient et nettoient à fond sans laisser de résidus. Il est possible d'enlever les traces éventuelles de calcaire en utilisant des produits spécifiques. Pour obtenir à nouveau une surface brillante, utiliser un polish ordinaire de carrossier.

⚠ **IMPORTANT: EVITER ABSOLUMENT L'EMPLOI DE DÉTERGENTS ABRASIFS, ALCOOL OU PRODUITS A' BASE D'ALCOOL, ACETONE OU AUTRES SOLVANTS.**

#### EN - PRODUCT GUARANTEE

The manufacturer guarantees its products against manufacturing and material defects for a period of 24 months from the date of purchase appearing on the sales receipt or invoice and only where such defects are confirmed by personnel authorised by the manufacturer. This guarantee is limited to the repair and replacement of defective parts. This guarantee does not cover replacement of the entire product. The product must be installed in accordance with good technical practices by suitably skilled personnel. Any surface or finish defects must be notified before final installation. We recommend that you check the product before installation and carry out a preliminary test run.

• **Cleaning acrylic surfaces and fittings** - Clean acrylic surfaces using a good quality household liquid detergent and a soft cloth or sponge. To prevent the build-up of limescale deposits, wipe acrylic surfaces dry with a chammy leather or a soft, lint-free cloth that removes stubborn deposits without leaving traces. Limescale deposits may be removed using specific detergent products. To restore shine to the acrylic surface polish with an ordinary wax polish such as car wax.

⚠ **DO NOT USE ABRASIVE CLEANERS, ALCOHOL, ALCOHOL BASED CLEANERS, ACETONE OR OTHER SOLVENTS.**

#### ES - GARANTÍA

El fabricante garantiza sus propios productos contra defectos de fabricación y de material - sólo si dichos defectos han sido constatados por personal autorizado por la Empresa - durante un periodo de 24 meses a partir de la fecha de compra indicada en el recibo o en el ticket de caja. La garantía consiste en la reparación o sustitución de las partes que se consideren defectuosas; queda excluida la sustitución completa del producto. El producto debe ser instalado por personal especializado según las indicaciones de instalación; los posibles defectos superficiales y/o de acabado deberán ser señalados antes de la instalación definitiva. Se recomienda controlar el producto y comprobar el correcto funcionamiento del mismo, antes de instalarlo.

• **Limpieza de la superficie acrílica y de los accesorios** - Para llevar a cabo la limpieza normal de las superficies acrílicas usar detergentes líquidos con una esponja o un paño suave. Se recomienda utilizar productos no abrasivos. Para evitar que se formen depósitos de cal se recomienda secar las superficies acrílicas después del uso, con un paño gamuzado o de microfibra, que limpie a fondo sin dejar rastros. Los posibles restos de cal pueden eliminarse con cualquier producto antical. Para reavivar el brillo de la superficie acrílica usar un pulimento de los que se usa para abrillantar la carrocería de los coches.

⚠ **NO SE DEBEN APLICAR BAJO NINGÚN CONCEPTO PRODUCTOS ABRASIVOS, ALCOHOL, SUSTANCIAS A BASE DE ALCOHOL, ACETONA U OTROS DISOLVENTES.**

#### DE - GARANTIE

Die vom Hersteller gewährte Garantie umfaßt Produktions- und Materialfehler lediglich, wenn diese vom Unternehmen befugtem Personal festgestellt werden für eine Dauer von 24 Monaten ab Datum des Erwerbs und unter Vorlage der Quittung bzw. des Kassenzettels. Die Garantie besteht in der Reparatur und/oder im Ersatz der als defekt betrachteten Teile. Die Garantie umfaßt nicht den kompletten Ersatz des Produkts. Das Produkt muß fachmännisch von befugtem Personal installiert worden sein; eventuelle Oberflächenfehler und/oder das Finish betreffende Mängel müssen vor dem endgültigen Aufbau gemeldet werden. Es empfiehlt sich, das Produkt vor dem Aufbau zu überprüfen und einer Funktionskontrolle zu unterziehen.

• **Reinigung der Acrylflächen und der Zubehörteile** - Für die normale Reinigung der Acrylflächen flüssige Reiniger (z.B. Vim flüssig) und einen weichen Schwamm bzw. ein weiches Tuch verwenden. Um die Bildung von Kalkablagerungen zu vermeiden, die Acrylflächen nach dem Gebrauch möglichst mit einem Hirschleder oder einem Mikrofaser Tuch trocknen, das eine gründliche Reinigung ohne Rückstände garantiert. Eventuelle Kalkablagerungen werden mit speziellen kalklösenden Produkten entfernt. Um glänzende Oberflächen wieder zu erhalten, eine normale Autopolitur verwenden.

⚠ **AUF KEINEN FALL SCHEUERENDE REINIGER, ALKOHOL, REINIGER AUF ALKOHOLBASIS, AZETON ODER ANDERE LÖSEMittel VERWENDEN. LET OP, PAS VÓÓR EERSTE**







998398