

FR | Ne pas enlever
 EN | Do not remove
 ES | No retirar
 IT | Non rimuovere
 DE | Nicht entfernen
 NL | Verwijder niet

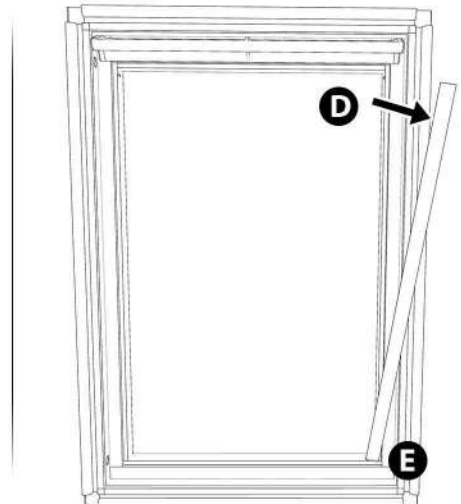

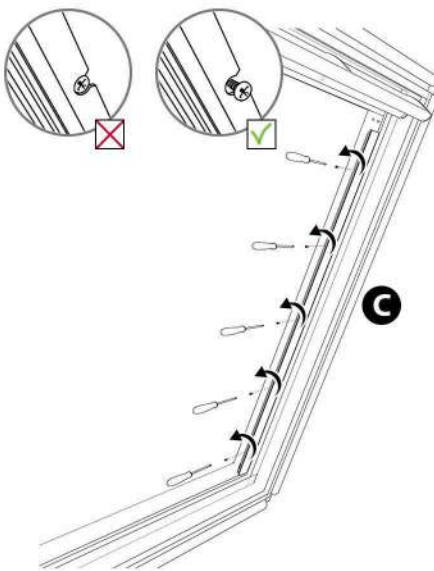

- FR** | Le store remonte mal :
Le ressort est détendu, voici comment le retendre.
- EN** | The blind goes back badly:
The spring is relaxed, here is how to tighten it.
- ES** | El estor sube mal :
El resorte está distendido, aquí le mostramos como se aprieta
- IT** | Il ciechi torna male:
La molla è rilassata, ecco come stringerla.
- DE** | Das Rollo lässt sich nur schwer hoch schieben:
Die Feder ist nicht richtig gespannt, so spannt man sie richtig.
- NL** | De blinde gaat slecht terug:
De lente is ontspannen, hier is hoe het moet worden aangescherpt.

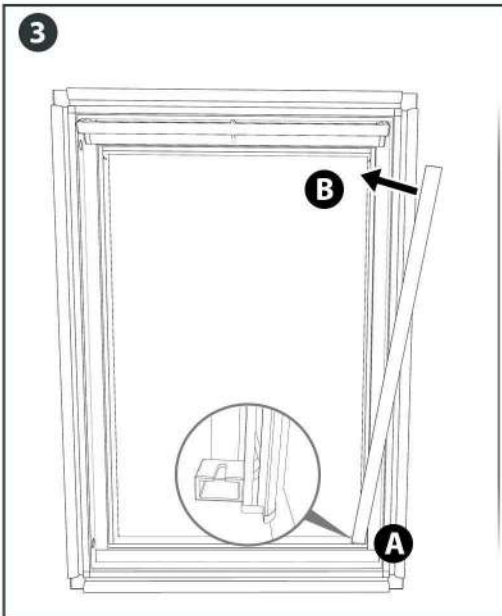
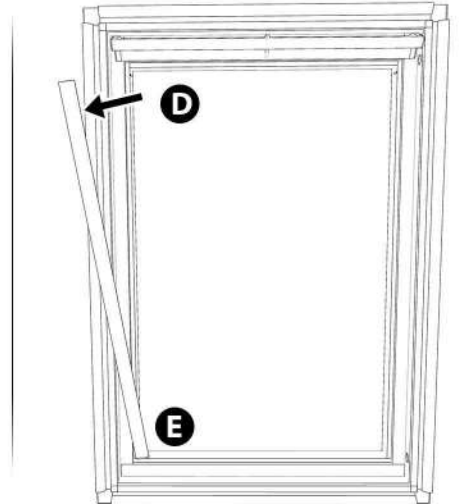
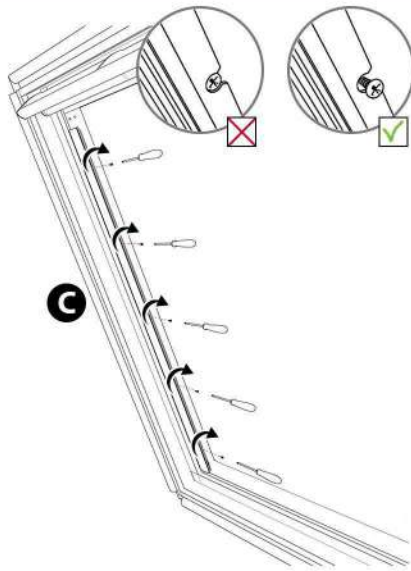
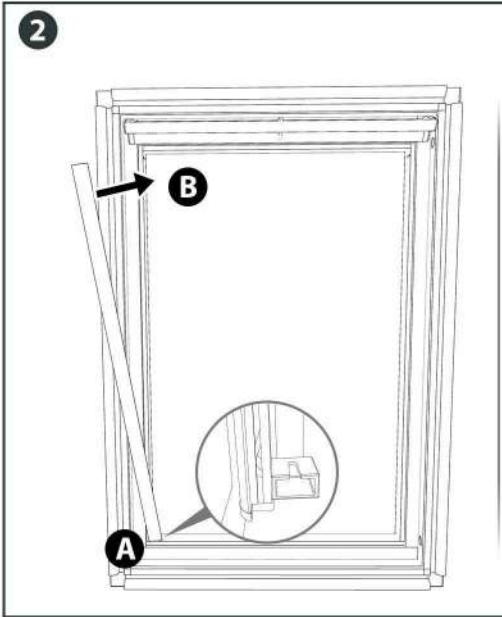
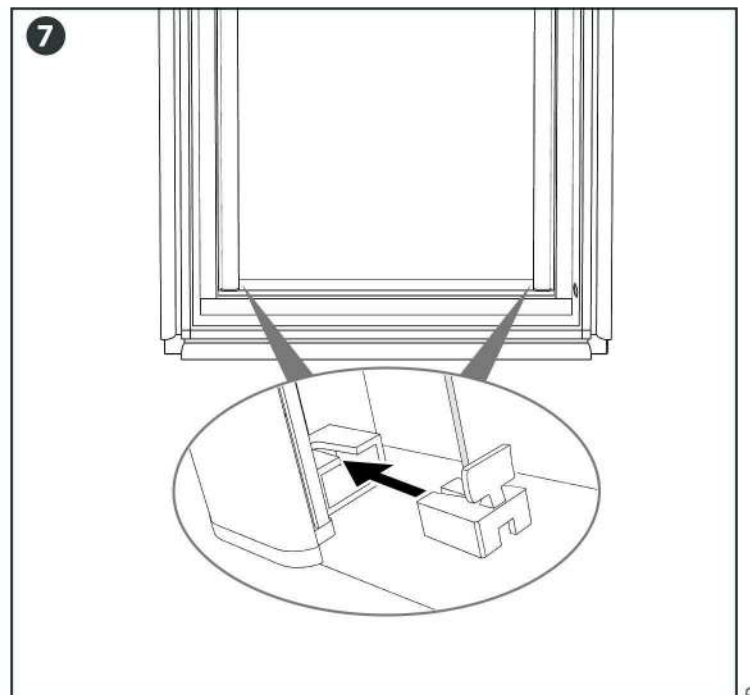
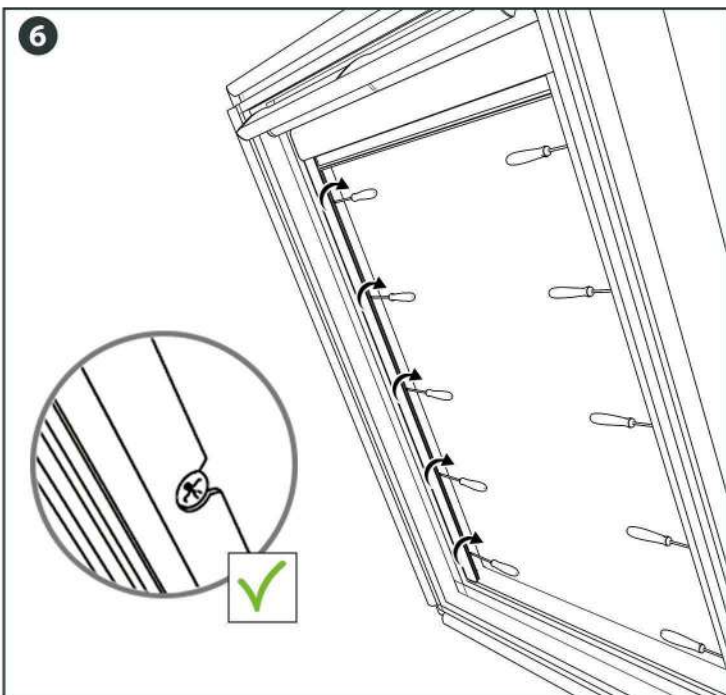
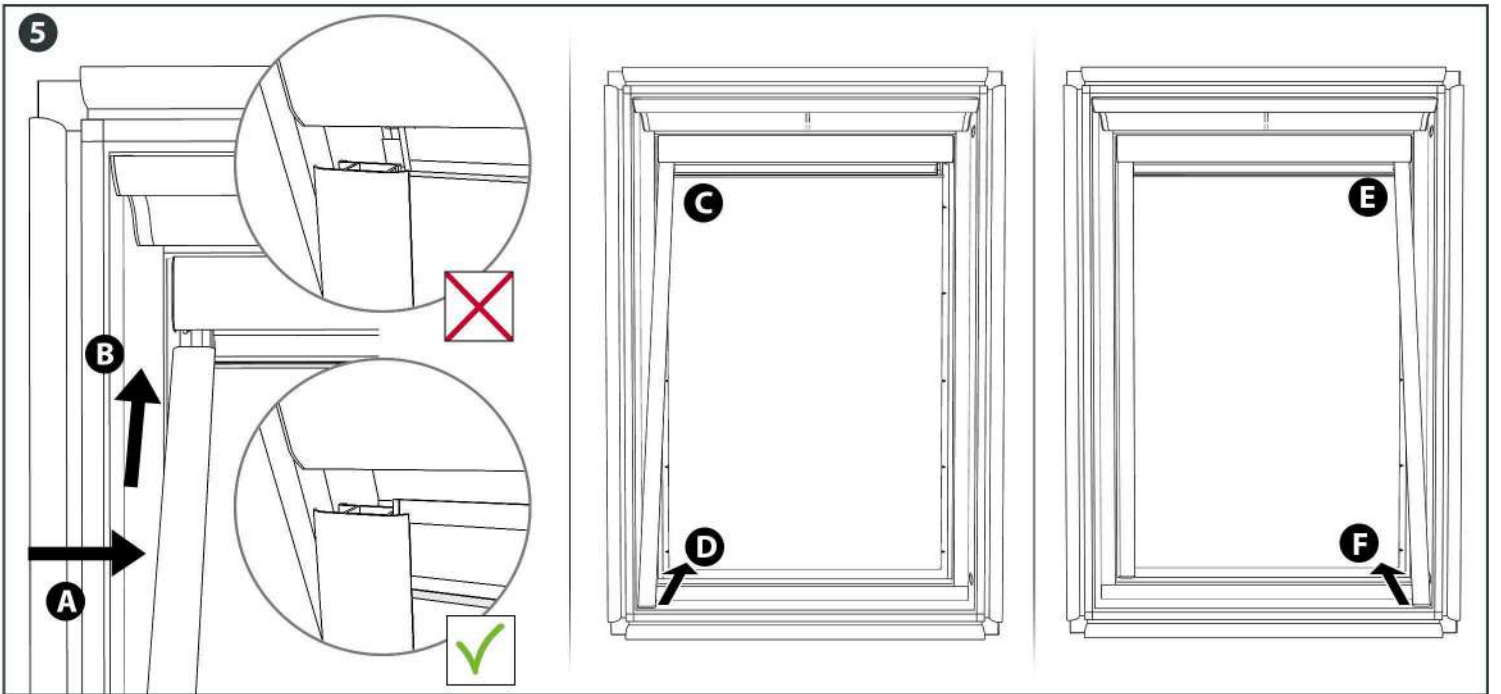
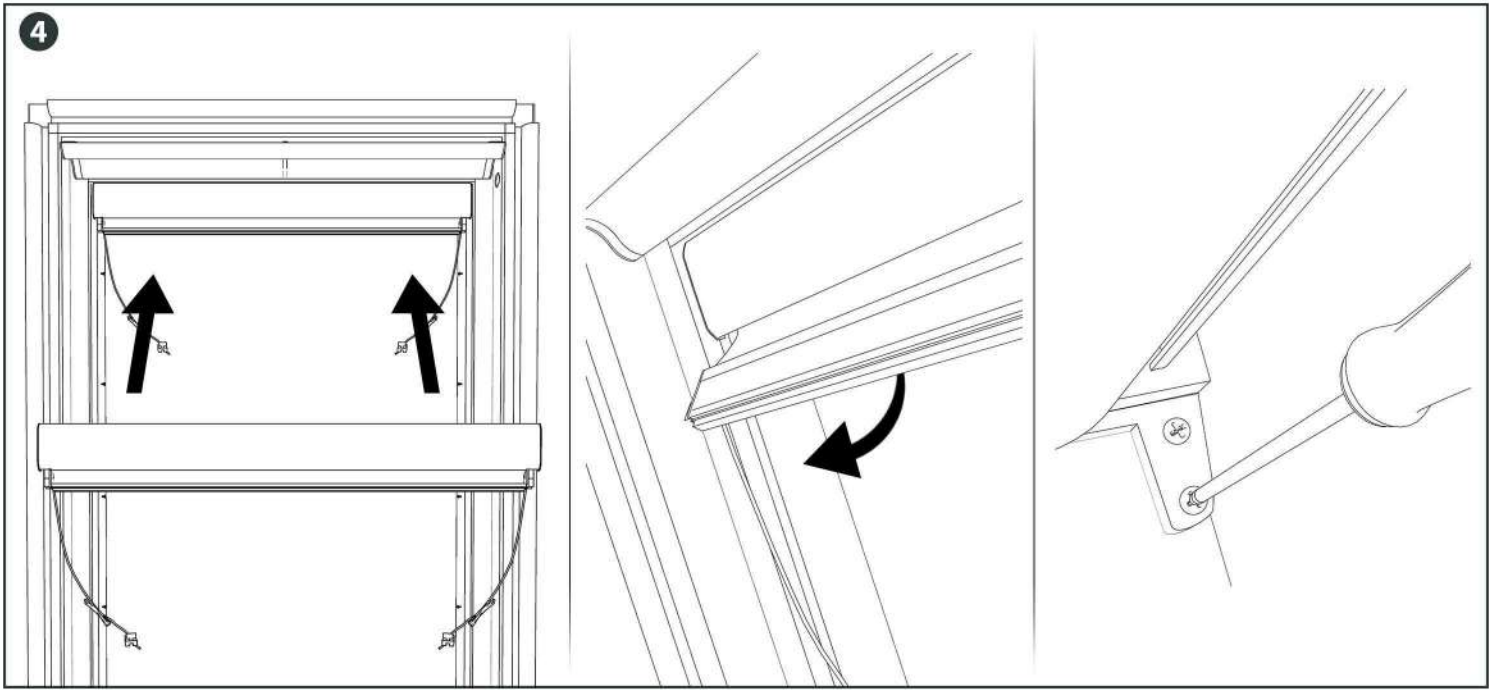
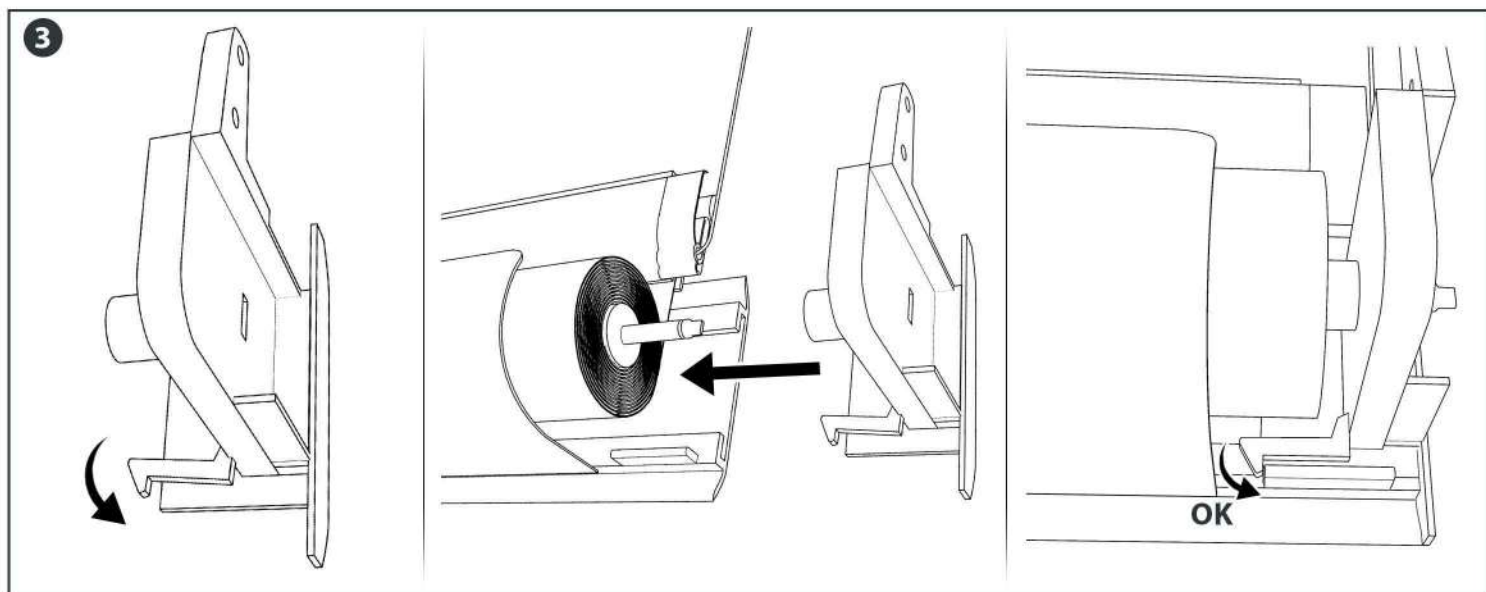
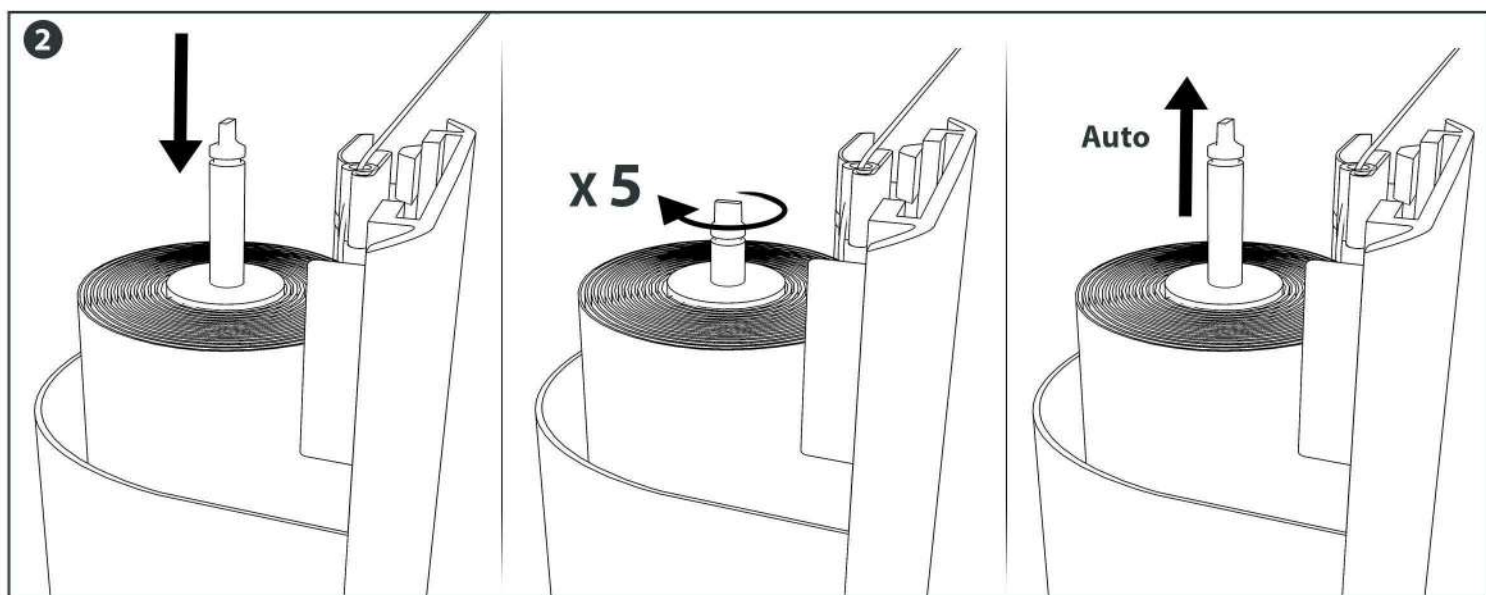
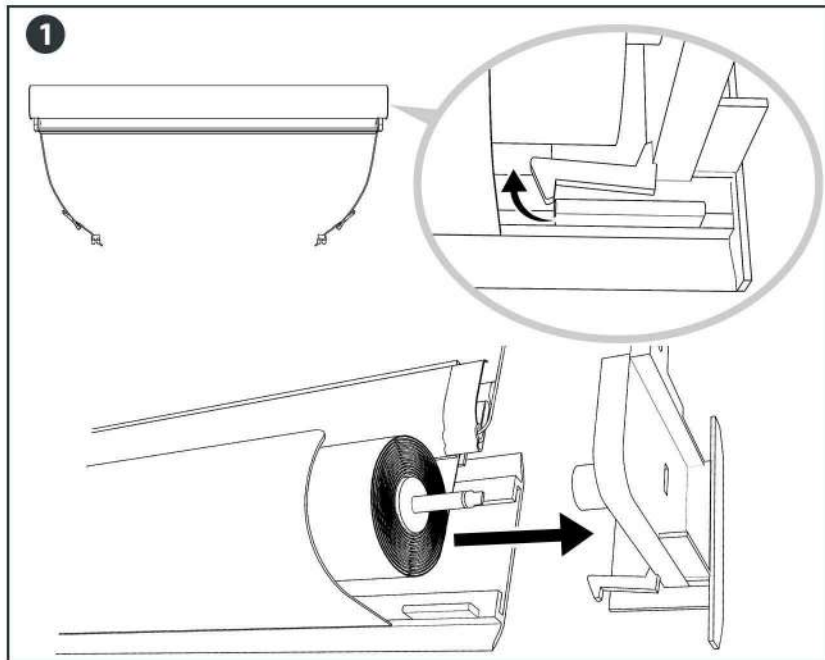
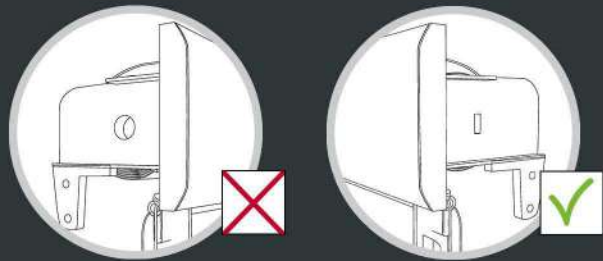

- FR** | Ne pas tendre trop le ressort sinon le store aura du mal à rester fermé.
- EN** | Do not tighten the spring too much, otherwise the blind will close badly.
- ES** | No tense demasiado el resorte, de lo contrario el estor tendrá dificultades para permanecer cerrado.
- IT** | Non stringere troppo la molla, altrimenti il cieco si chiuderà male.
- DE** | Die Feder nicht zu stark spannen, sonst schließt das Rollo schlecht.
- NL** | Draai de veer niet te veel aan, anders komt de blinde slecht dicht.