

**HYUNDAI**  
POWER PRODUCTS

# **PETROL CONVERTER GENERATOR HY3000CI**

---

**User Manual**



# INDEX

	<b>CONTENTS</b>	<b>PAGE NO.S</b>
1	SAFETY	3 - 8
2	PART LOCATIONS	9
3	PRE OPERATION CHECKS	10 - 12
4	STARTING PROCEDURE	12 - 13
5	STOPPING PROCEDURE	13
6	USING THE MACHINE	14 - 16
7	MAINTENANCE	17 - 21
8	STORAGE & TRANSPORTATION	21 - 22
9	TROUBLE SHOOTING	23
10	SPECIFICATION	24
11	RECYCLING & PRODUCT DISPOSAL	25
12	DECLARATION OF CONFORMITY	26
13	CONTACT DETAIL	27
14	WARRANTY	27
15	MANUAL UPDATES	27

# 1. SAFETY

## 1.1 General Safety Notes.

- 1.2 The operator of the machine is responsible for, and has a duty of care in making sure that the machine is operated safely and in accordance with the instructions in this user manual. Keep the manual safe and pass it on if the machine is loaned or sold to another user.
- 1.3 Please note the following safety points.
- 1.4 The machine should never be left in a condition which would allow an untrained or unauthorised person/s to operate this machine.
- 1.5 All due care and diligence should be taken by the operator for the safety of and with regard to those around whilst using the machine.
- 1.6 Some or all of the following - warning signs, symbols and/or PPE pictograms may appear throughout this manual. You **MUST** adhere to their warnings. Failure to do so may result in personal injury to yourself or those around you.



## DANGER

Indicates a hazard, which, if not avoided, could result in serious injury or death.



## WARNING

Indicates a hazard, which, if not avoided, could result in serious injury.



## CAUTION

Indicates a hazard which, if not avoided, might result in minor or moderate injury.



## NOTE

Indicates a situation that could easily result in equipment damage.

READ and keep the manual safe and pass it on if the machine is loaned or sold to another user.

You **MUST** fully understand all instructions to ensure you use and operate the machine safely.

Appropriate Personal Protective Equipment (PPE), **MUST** be worn at all times when operating or repairing the machine.



HAND  
PROTECTION  
MUST BE WORN



EYE  
PROTECTION  
MUST BE WORN



PROTECTIVE  
CLOTHING  
MUST BE WORN



HEARING  
PROTECTION  
MUST BE WORN



FOOT  
PROTECTION  
MUST BE WORN



HEAD  
PROTECTION  
MUST BE WORN



RESPIRATOR  
MUST BE WORN



FACE SHIELD  
MUST BE WORN

1.10 Carbon Monoxide (where applicable).

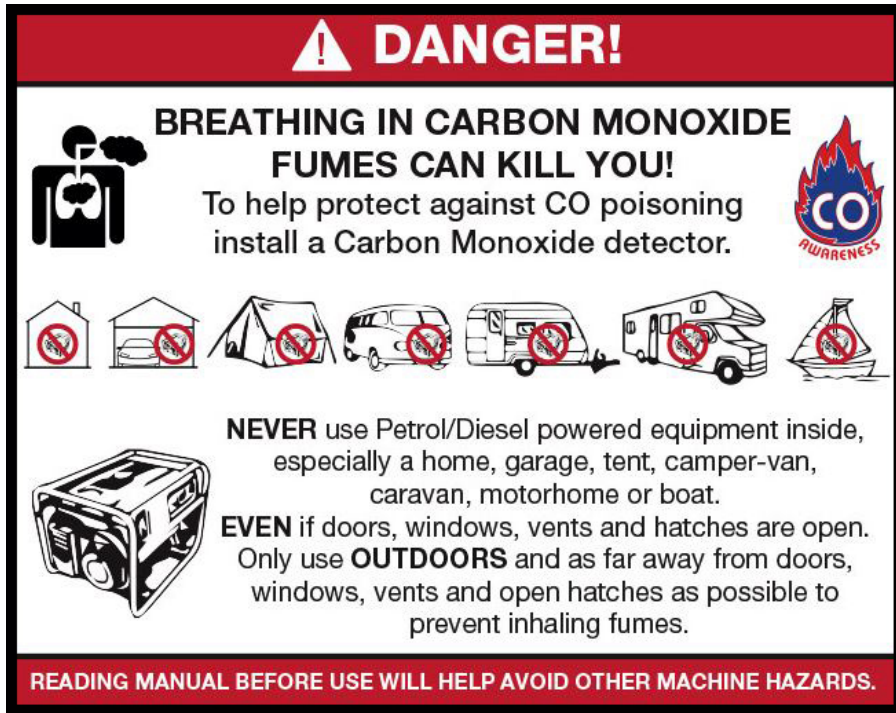

- 1.11 Carbon monoxide is a colourless and odourless gas. Inhaling this gas can cause death as well as serious long term health problems such as brain damage.
- 1.12 The symptoms of carbon monoxide poisoning can include but are not limited to the following;  
Headaches, dizziness, nausea, breathlessness, collapsing or loss of consciousness.
- 1.13 Carbon monoxide poisoning symptoms are similar to flue, food poisoning, viral infections and simply tiredness. It is quite common for people to mistake this very dangerous poisoning for something else.
- 1.14 To avoid carbon monoxide poisoning **DO NOT** use Petrol/Diesel powered equipment inside any of the following; Home, garage, tent, camper van, mobile home, caravan or boat. This is not exhaustive and if you are in any doubt contact your dealer.
- 1.15 If you think you have or someone around you has been affected by carbon monoxide poisoning;
- 1.16 Get them fresh air immediately, by leaving the affected area or by opening doors and windows. If safe and practical to do so make sure that the machine is turned off. **DO NOT** enter a room you suspect of having carbon monoxide present – instead call the emergency services.
- 1.17 Contact a Doctor immediately or go to Hospital – let them know that you suspect carbon monoxide poisoning.
- 1.18 **DO NOT** use in an enclosed area or moving vehicle.

1.20 **General Fuel Safety (where applicable).**



## **CAUTION**

### **ALL FUELS ARE FLAMABLE**

1.21 Fire Hazard – keep fuel away from all sources of ignition for example heaters. Lamps, sparks from grinding or welding.



1.22 **DO NOT** carry out hot work on tanks that have contained fuel.

1.23 **ALWAYS** keep the work area tidy.

1.24 **ALWAYS** clean up spills promptly using absorbent granules and a lidded bin.

1.25 **ALWAYS** dispose of waste fuels correctly.

1.30 **Fueling/De-fueling (where applicable).**



## **CAUTION**

### **ALL FUELS ARE FLAMABLE**

1.31 **ALWAYS** fuel and defuel in a well ventilated area outside of buildings.

1.32 **ALWAYS** wear correct, suitable and fit for purpose Personal Protective Equipment (PPE), suggested items are but not limited to safety gloves, overalls.



1.33 When fueling/de-fueling **ALWAYS** avoid inhaling fumes.

1.34 When de-fueling **ALWAYS** use a proper fuel retriever.



1.35 **ALWAYS** carry fuel in the correct and clearly marked container.

1.40 **Electrical Safety (where applicable).**

1.41 Electricity can kill – **NEVER** work on **LIVE/ENERGISED** equipment.

1.42 Prior to carrying out any maintenance work you **MUST** identify electrical isolation methods and isolate all electrical supplies.

1.43 Prior to use and with all electrical supplies isolated, you **MUST** check all electrical cables, plugs and connectors for the following;

1.44 Are intact and have no signs of damage, to include but not limited to bare wires, chaffing, cuts and loose wiring.

1.45 If there are any signs of damage, the damaged item **MUST** be taken out of service until the damage has been repaired by an electrically competent person.

1.46 All trailing cables should be routed so as not to cause any kind of trip hazard.

1.47  **NEVER** work on or near electricity with wet hands, wet clothing and wet gloves.



### 1.50 Batteries (where present).

1.51 Batteries present a risk if they become damaged by the possible leaking of electrolyte. This electrolyte is an acid and can cause serious burn injuries. Care should be taken when working on or near them. **NOTE** the electrolyte may be in a liquid or gel form.

1.52 Should you come in to contact with electrolyte you should;

1.53 Remove all clothing contaminated with electrolyte. If you cannot remove then saturate them in water.

1.54 Get medical assistance as soon as possible. You must advise the medical staff of the type of acid.

1.55 Lead/acid battery = dilute sulphuric acid.

1.56 Nickel/cadmium = potassium hydroxide alkali electrolyte.

1.57 Use fresh running water to wash off excess electrolyte, continue this until medical assistance arrives. Make sure that you do not wash the electrolyte to another part of your body or face.

1.58 If electrolyte comes in to contact with Eyes the electrolyte needs to be immediately washed away with large amounts of water. Make sure that you do not wash the electrolyte to another part of your face or body.

1.59 Gasses from charging batteries are highly flammable and great care should be taken to charge in well ventilated areas.

1.59.1  There is an explosion risk if the battery terminals are short circuited, when connecting/disconnecting **ALWAYS** exercise great care so that the terminals or battery leads are **NOT** allowed to touch and cause a spark. **ALWAYS** use suitable insulated tools.



### 1.60 Vibrations (where applicable).

1.61 Prolonged use of hand held (operated) machines will cause the user to feel the effects of/from vibrations. These vibrations can lead to white finger (Raynaud's phenomenon) or carpal tunnel syndrome. This condition reduces the ability of the hand to feel and regulate temperature, causing numbness and heat sensations and may cause never damage and circulatory tissue death.

1.62 Not all factors that lead to white finger disease are known, but cold weather, smoking and other diseases that affect blood vessels and blood circulation as well as large and long-lasting impact of shocks are considered factors in the formation of white finger. Note the following to reduce the risk of white finger and carpal tunnel syndrome;

1.63 Wear gloves and keep your hands warm.

1.64 Take regular breaks.

1.65 All of the above precautions may help reduce the risk of white finger disease but not rule out the carpal tunnel syndrome. Long-term and regular users are therefore

recommended to observe the condition of your hands and fingers. Seek medical attention immediately if any of the above symptoms should occur.

## 1.70 Noise (where applicable).

1.71 The operating noise of the machine can damage your hearing. Wear hearing protection such as earplugs or ear defenders to protect your hearing. Long-term and regular users are advised to have hearing checked regularly. Be especially vigilant and cautious when hearing ear protection because your ability to hear alarm warnings will be reduced.

1.72 Noise emissions for this equipment is unavoidable. Carry out noisy work at approved times and for certain periods. Limit the working time to a minimum. For your personal protection and protection of people working nearby it is also advisable for them to wear hearing protection.

1.73 See Certificate of Conformity section for Outdoor Noise declaration of conformity.



## MACHINE SPECIFIC SAFETY

### 1.80 General Machine Safety.

1.81 Read the owner's manual carefully to understand how to operate this machine properly.

1.82 You should **NEVER** use the machine when;

1.83 Wearing loose clothing, barefoot or sandals.

1.84 Under the influence of drink or drugs or as a result of having taken medication for cold or flu, or any other times when a possibility exists that your judgement might be impaired or that you might not be able to operate the machine properly and in a safe manner.

1.85 Suffering from exhaustion or lack of sleep.

1.86 When the ground is slippery or when other conditions exist which might make it not possible to maintain a steady posture.

1.87 At night, at times of heavy fog, or at any other times when your field of vision might be limited and it would be difficult to gain a clear view of the area.

1.88 During rain storms, lightning storms, at times of strong or gale force winds, or at any other times when the weather conditions might make it unsafe to use this product.

1.89 **NEVER** run the engine indoors. The exhaust gasses contain harmful carbon monoxide.

1.90 When using this machine for the first time and before actual work, you **MUST** learn how to handle the machine from an experienced or skilled person.

1.91 Limit the amount of time using the machine continuously to somewhere around 10 minutes per session and take 10 to 20 minutes of rest between sessions. Also try to keep the total amount of work in a single day limited to 2 hours or less.

- 1.92 **NEVER** allow children or anyone unable to fully understand the directions given in this manual to operate this product.
- 1.93 Make sure you keep this manual handy so you may refer to it whenever questions arise and ensure you pass this manual on if the machine is loaned or sold.
- 1.94 Correct Personal Protective Equipment (PPE) **MUST** be worn at all times when operating or repairing this machine. This should include but is not limited to;



HAND  
PROTECTION  
MUST BE WORN



EYE  
PROTECTION  
MUST BE WORN



PROTECTIVE  
CLOTHING  
MUST BE WORN



HEARING  
PROTECTION  
MUST BE WORN



FOOT  
PROTECTION  
MUST BE WORN



HEAD  
PROTECTION  
MUST BE WORN



RESPIRATOR  
MUST BE WORN



FACE SHIELD  
MUST BE WORN



## 2. PART LOCATIONS

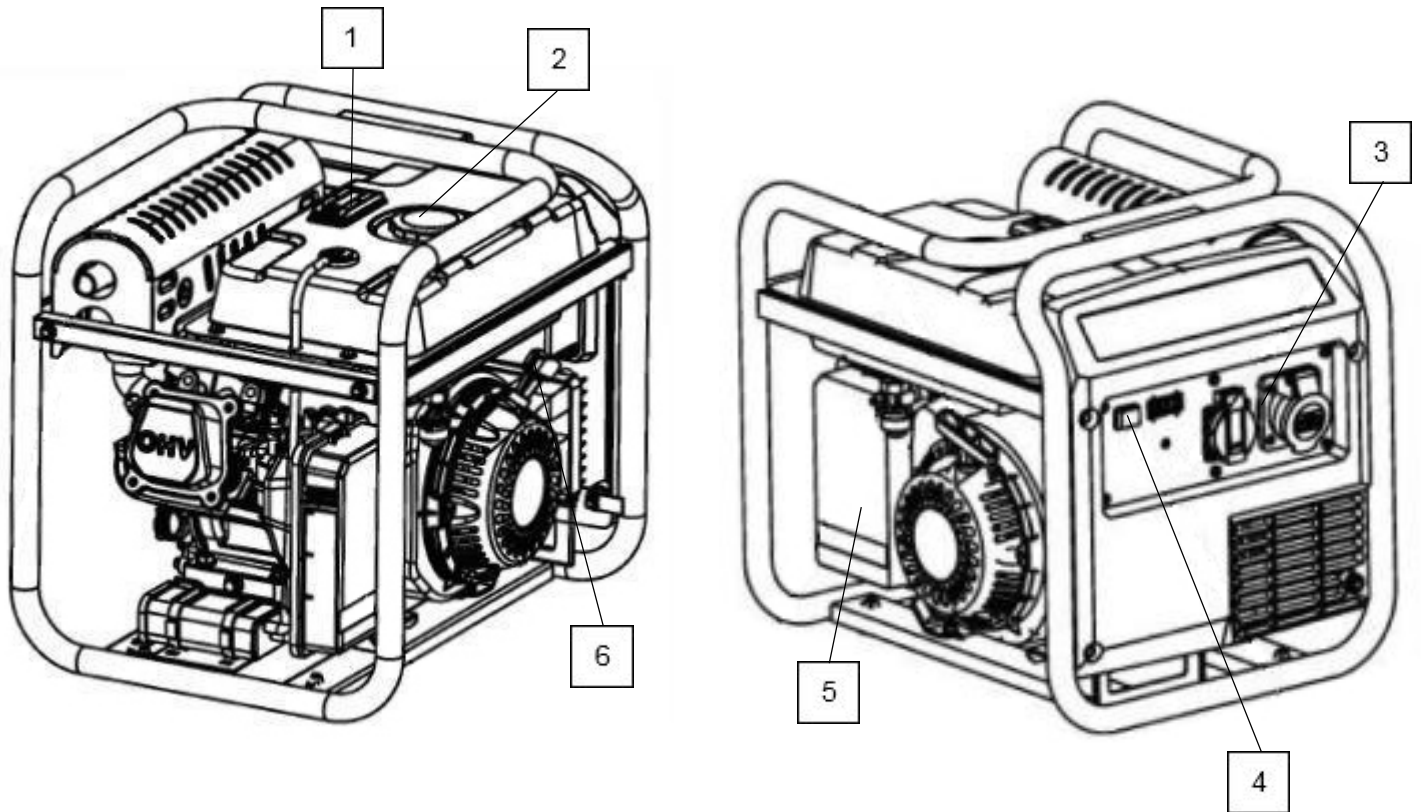

1	Fuel Gauge	4	Engine Switch
2	Fuel Filler Cap	5	Air Filter
3	Control Panel	6	Recoil Start Handle

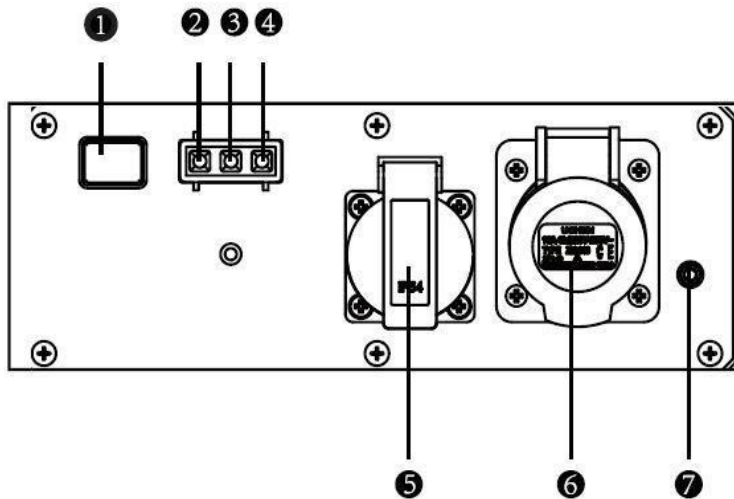

- ① engine switch
- ② output indicator (green)
- ③ overload indicator (red)
- ④ Oil indicator (red)
- ⑤ AC output
- ⑥ AC output
- ⑦ Ground terminal

### 3. PRE OPERATION CHECKS



#### NOTE

This machine is shipped without oil or fuel. It is essential that fuel and oil levels are checked and maintained before each operation.

**ALWAYS** check the fuel and oil level with the machine on flat level ground.

Fuel Type	Unleaded Petrol
Oil Type	SAE 30 Mineral Oil or SAE 15W40 Mineral Oil



#### CAUTION

##### FOR OUTDOOR USE ONLY

This machine produces carbon monoxide – a poisonous, colourless and odourless gas that can cause death or serious injury.



#### CAUTION

##### ALL FUELS ARE FLAMMABLE

**ALWAYS** handle with extreme care and in a well-ventilated area.

Allow the engine to cool and remove the spark plug HT lead before refuelling or defueling.

## FUEL

- 3.0 Place the machine on flat level ground in a well-ventilated area away from any sources of ignition and at least 1.5m away from any buildings.
- 3.1 Clean the area around the fuel filler cap to prevent dirt and debris from entering the fuel tank.
- 3.2 Unscrew the fuel filler cap and slowly fill with unleaded petrol.  
**YOU MUST** allow a 25mm gap between the fuel and the top of the fuel tank to allow for fuel expansion.
- 3.3 Refit the fuel filler can securely and wipe up any spills.

Fuel Filler Cap

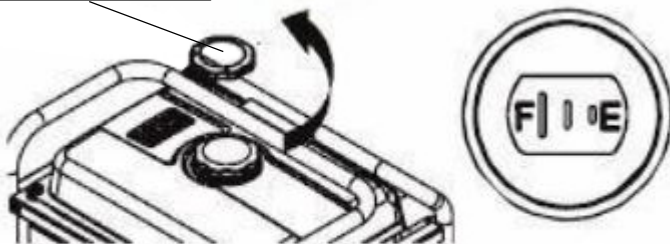

Upper Limit Mark

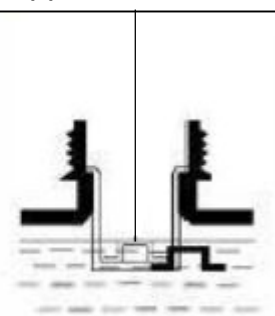

## OIL

- 3.4 Place the machine on a flat level surface.
- 3.5 Clean the area around the oil filler cap/dipstick to prevent dirt and debris from entering the engine.
- 3.6 Unscrew and remove the oil filler cap/dipstick and wipe with a lint free cloth.
- 3.7 For machines without a dipstick, the oil level is determined by filling to the upper thread level.  
For machines with a dipstick, the oil level is determined by the upper level limit mark on the dipstick.
- 3.8 Slowly fill with oil to the correct level. Stop occasionally to check the level.  
**DO NOT** overfill.
- 3.9 Once full, refit the oil filler cap/dipstick and tighten securely.

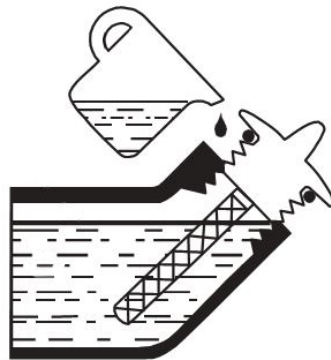

## GROUNDING

- 3.10 The Requirement for Electrical installations BS 7971:2008 requires that the frame and external electrically conductive part of this generator be properly connected to an approved earth ground.
- 3.11 Proper grounding of the generator will help prevent electric shock in the event of ground fault condition in the generator or in connected electrical devices.
- 3.12 Proper grounding also helps dissipate static electricity, which often builds up in ungrounded devices.
- 3.13 Floating earth portable generator use.
- 3.14 This range of generators adopt a floating earth configuration which means that the Neutral of the alternator is not connected to the Earth of the machine.

- 3.15 It is therefore **IMPORTANT** that you **ONLY** use the generator to supply equipment in the following combinations.  
 7.40 One or more of CLASS II equipment.  
 7.41 Only **ONE** item of CLASS I equipment.  
 7.42 One or more of CLASS II equipment and only **ONE** item of CLASS I equipment.
- 3.16 CLASS I equipment has a GREEN/YELLOW earth wire connected inside the plug.
- 3.17 CLASS II equipment **DOES NOT** have a GREEN/YELLOW earth wire connected inside the plug.
- 3.18 CLASS II equipment will have the following symbol embossed or printed on the casing.

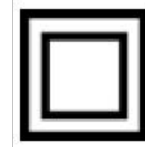

## 4. STARTING PROCEDURE



### NOTE

This machine is shipped **WITHOUT** Oil and Fuel and will require filling **BEFORE** use. Failure to do so will result in engine damage that will not be covered by the warranty.



### CAUTION

Before starting, ensure the machine is clear of materials and all non-essential persons.



### NOTE

**NEVER** start or stop the engine with electrical devices plugged in to the power outlets and devices turned on.

Unplug all electrical loads from the unit's power outlets before starting the engine.

- 4.0 Move the fuel tap to the ON position.

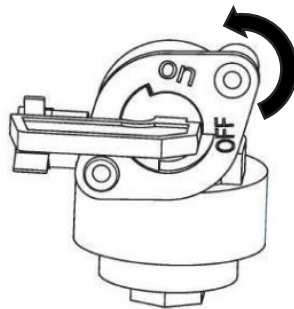

- 4.1 Turn the engine switch to the 'ON' position.

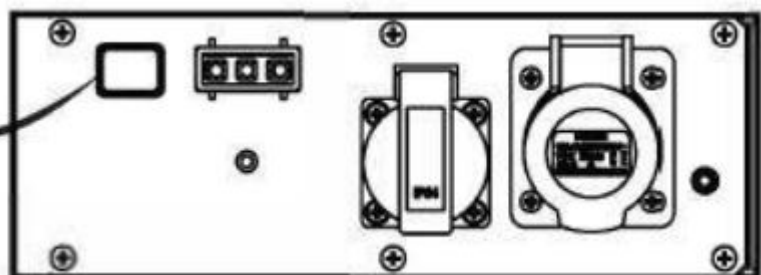
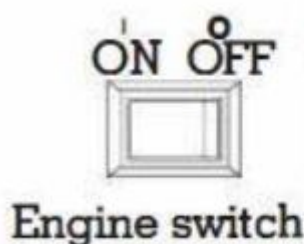

- 4.2 **COLD START:** Move the choke lever to the START Position.  
**WARM START:** Move the choke lever to the RUN position.

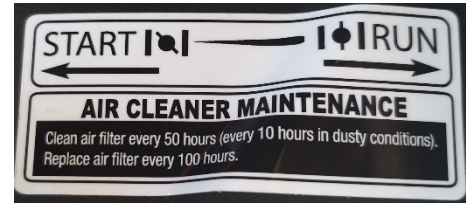
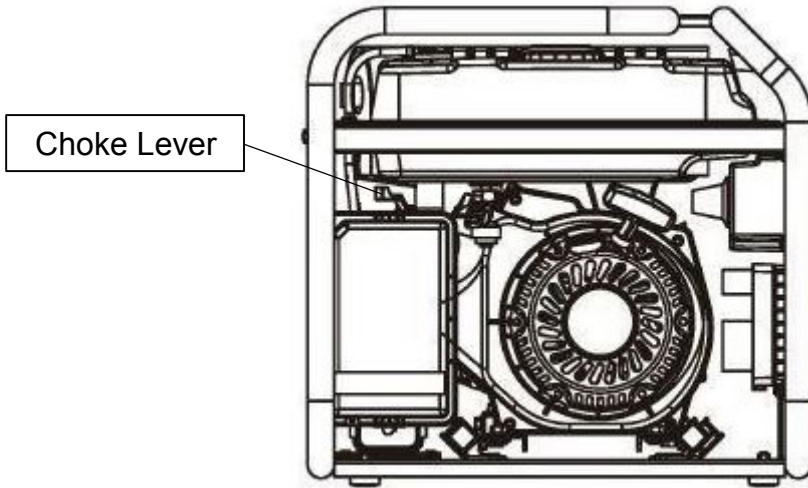

- 4.3 Gently pull the recoil start handle until you begin to feel resistance.  
4.4 Once you feel resistance, pull the recoil starter handle swiftly until the engine starts.  
**NOTE:** Return the recoil starter handle slowly by hand. **DO NOT** allow it to snap back.

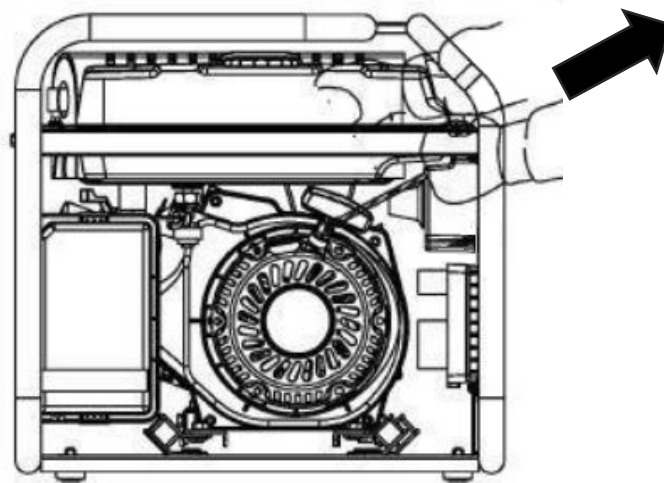

- 4.5 **NOTE:** As soon as the engine starts, the choke **MUST** be moved to the **RUN** position.

## 5. STOPPING PROCEDURE

- 5.0 Turn off and unplug all connected devices.  
5.1 Allow the engine to sit at idle under no load, for 20 to 30 seconds.  
5.2 Move the engine switch to the OFF position.  
5.3 Turn the fuel tap to the OFF position.

## 6. USING THE MACHINE



### **DANGER**

#### **FOR OUTDOOR USE ONLY**

This machine produces carbon monoxide – a poisonous, colourless and odourless gas that can cause death or serious injury.

Petrol is highly flammable, always handle with extreme care and in a well-ventilated area.

**ALWAYS** remove the spark plug HT lead cap when refuelling, defueling or checking the machine.



### **NOTE**

**DO NOT** overload the generator. **DO NOT** overload individual sockets.

If the current rating of any socket is exceeded, the generator will cut power to the device.



### **NOTE**

Fuel and Oil levels **MUST** be checked before each operation.

- 6.0 If the engine shuts down by itself and there fuel tank has enough petrol, check the engine oil level.  
The engine oil level should be checked daily.
- 6.1 **DO NOT** overload the generator. **DO NOT** overload individual sockets.

## CONNECTING ELECTRICAL LOADS

- 6.2 Calculate the rated watts (or amps) of all loads to be connected at one time. This total should not be greater than the circuit breaker rating of the output socket supplying the power or the rated wattage/current capacity of the generator.
- 6.3 Allow the engine to run until the rpm is stable and the engine has had time to warm up.
- 6.4 Plug in the electrical load with the device turned off.
- 6.5 Turn the device on.

## DISCONNECTING ELECTRICAL LOADS

- 6.6 Turn the device off.
- 6.7 Unplug the device from the generator socket.

## OVERLOADING

- 6.8 Overloading the generator in excess of its rated wattage capacity can result in damage to the generator and to the connected electrical devices.
- 6.9 Observe the following to prevent overloading the unit;
- 6.10 Add up the total wattage of all electrical devices to be connected at one time. This total, including starting wattage, should not be greater than the generators wattage capacity.

- 6.11 The rated wattage of lights can be taken from light bulbs. The rated wattage of tools, appliances and motors can usually be found on a data label or decal affixed to the device.  
If the appliance, tool or motor does not give a wattage, multiply volts by ampere rating to determine watts. (volts x amps = watts).
- 6.12 Some electrical induction motors require about three times more power for starting than running.  
The surge of power only lasts a few seconds when starting.  
You must make sure you allow for high starting wattage when selecting electrical devices to connect to the generator.
- 6.13 Calculate the watts needed to start the largest motor.  
Add that figure to the running watts of all the other connected loads.  
Start the largest motor first and only one more motor at a time.
- 6.14 The AC switch (circuit breaker) will turn off automatically when the load exceeds the generator output.
- 6.15 If the AC switch turns OFF before resetting, remove some of the load and keep below the rated output of the machine.
- 6.16 **DO NOT** connect the generator to a Mains AC socket in your building.  
This is known as 'back feeding' and is extremely dangerous and illegal.
- 6.17 To remain emissions compliant at high altitude (altitudes over 5000 feet), adjustment is required.  
This adjustment will cause decreased performance, increased fuel consumption and increased emissions.  
Contact your dealer for high altitude adjustment information.
- 6.18 Operating of the engine below 2500 feet with the high altitude kit is not recommended.
- 6.19 Under normal operation the output indicator light (GREEN) will remain on.
- 6.20 If the generator is overloaded or a connected device is in short-circuit, the output indicator light (GREEN) will turn off and the overload indicator light (RED) will turn on.

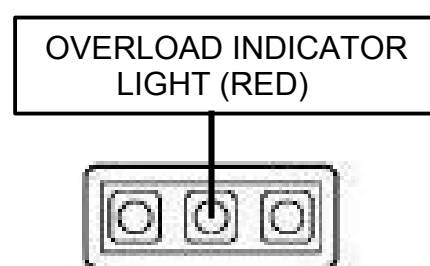
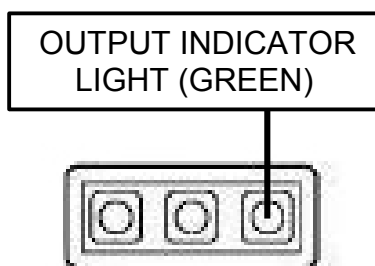

## LOW OIL ALERT

- 6.21 The low oil alert system is designed to prevent engine damage caused by insufficient oil in the engine.
- 6.22 If the engine oil level drops below this level, the engine will automatically shut down (the engine switch remains in the 'ON' position).
- 6.23 If the oil alert system shuts the engine down, the engine oil alert light (RED) will turn on.

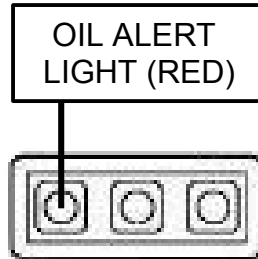

- 6.24 The engine will not restart until the correct oil level has been restored.

## EMERGENCY STOP



### NOTE

Only use the emergency stop in a true emergency situation. Continual use of using the emergency stop procedure could damage the engine.

- 6.25 To stop the engine in an emergency, turn the engine switch to the 'OFF' position.
- 6.26 Switch off all the connected appliances and unplug them from the generator.
- 6.27 Turn the fuel tap to the 'OFF' position.

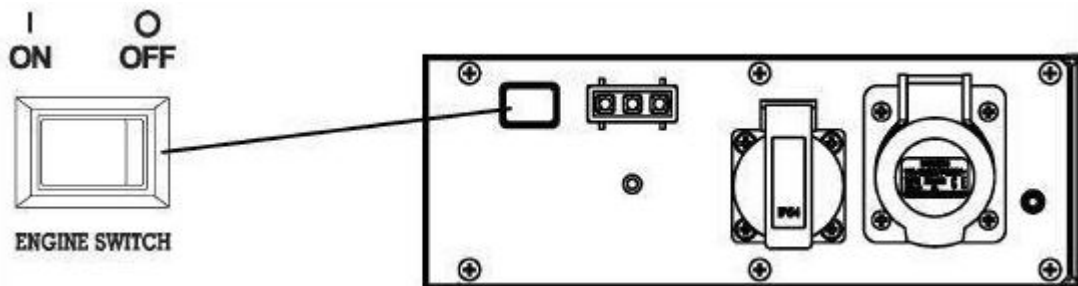



## 7. MAINTENANCE



### WARNING

All maintenance or repairs should be carried out by qualified persons only.

Only manufacturer approved parts should be used.

Allow the engine to cool completely before carrying out any maintenance or repairs.

Remove the spark plug HT lead cap before carrying out any maintenance or repairs.

		Each Use	1 <sup>st</sup> Month or 20 hours	Every 50 hours	Every 6 months or 100 hours	Every year or 300 hours
Engine Oil	Check	✓				
	Replace		✓		✓	
Air Filter	Check / Clean	✓ *				
	Replace					✓
Spark Plug	Check / Clean			✓		
	Replace					✓
Carburettor float bowl	Check / Clean					✓
Spark arrestor	Clean			✓		
Fuel Filter	Clean			✓		
	Replace					✓
Fuel Lines	Check	✓				
	Replace	As Required				

\* More frequently in dusty environments



## CAUTION

Risk of Burn from hot engine oil.  
Allow the oil to cool to WARM before changing.  
Warm oil will drain more effectively.

**Engine Oil: SAE30 Mineral Oil or SAE15w40 Mineral Oil**

- 7.0 Clean the area around the oil filler/dipstick.
- 7.1 Remove the oil filler/dipstick and place a suitable container underneath the oil drain plug.
- 7.2 Unscrew the oil drain plug and allow the oil to completely drain.
- 7.3 Inspect the oil drain plug and washer and replace if damaged.
- 7.4 Once the oil has drained, refit the oil drain plug and tighten securely.
- 7.5 With the machine on flat level ground, slowly fill with fresh engine oil through the oil filler.  
Stop occasionally to check the level.
- 7.6 For machines fitted with a dipstick, fill to the upper level mark on the dipstick.  
For machines without a dipstick, fill to the upper thread level on the fill hole.
- 7.7 Refit the oil filler cap/dipstick securely.
- 7.8 Wipe up any spilt oil.

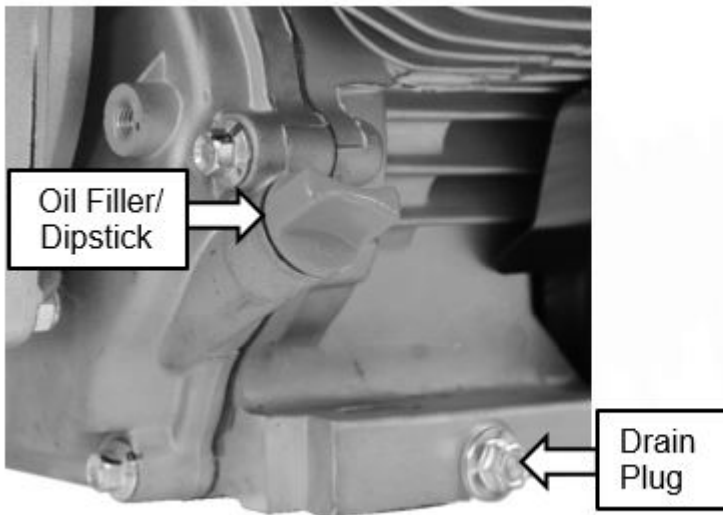



### NOTE

**NEVER** run the machine without an air filter being installed. A dirty air filter element affects the engine performance, increases fuel consumption and will make it difficult to start.

If you notice a loss in power, check the air filter.

You must ensure the air filter housing is free of dust and debris. **DO NOT** allow any dirt or debris to enter the carburettor.

- 7.9 Remove the air filter cover by unscrewing the air filter cover wing nut and remove the cover.
- 7.10 Undo the air filter element wing nut and remove the air filter element.
- 7.11 Ensure that no dirt or debris can enter the carburettor chamber.
- 7.12 Remove the foam filter element (if installed) from the paper element.
- 7.13 Inspect the air filter and if it shows any signs of damage or wear, replace immediately.
- 7.14 If installed, tap the paper element to remove dirt or debris and use a low pressure airline to blow from the inside of the element to remove the remaining dust.
- 7.15 If installed, wash the foam element in a warm soap solution and allow to air dry. **DO NOT** twist the element to dry.
- 7.16 Once dry, soak the foam element in fresh engine oil and remove any excess.
- 7.17 Reinstall the air filter and air filter cover.

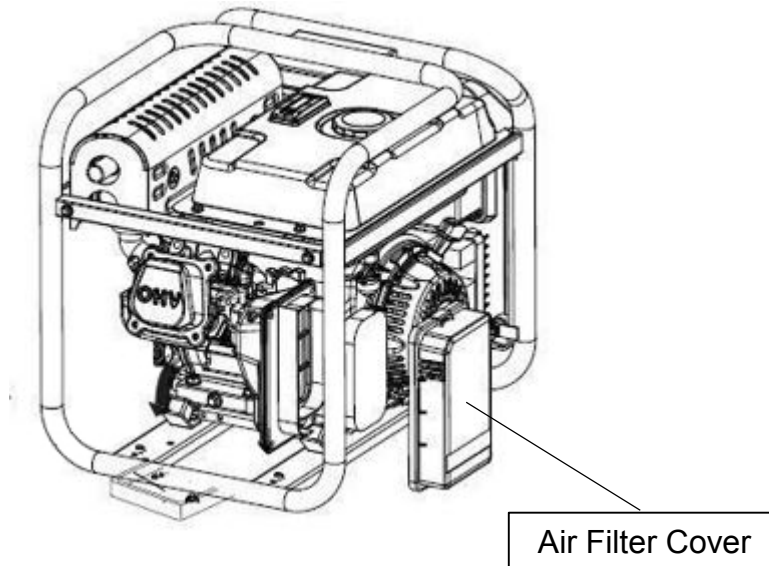

## SPARK PLUG



### CAUTION

**ALWAYS** allow the engine to cool completely before removing the spark plug.



### NOTE

**ALWAYS** replace the spark plug with the same model.

Incorrect spark plug installation can cause serious engine damage.

**DO NOT** allow dirt or debris to enter the cylinder bore.

- 7.18 Remove the spark plug HT lead cap.
- 7.19 Using a plug wrench, unscrew the spark plug in an anti-clockwise direction.
- 7.20 Inspect the spark plug and spark plug washer for any signs of wear or damage. If they show any signs, then replace immediately.
- 7.21 Remove any carbon deposits from the spark plug electrode by using a soft wire brush.
- 7.22 The spark plug gap should be 0.6 – 0.7mm (0.024" – 0.028"). Check the plug gap by using a feeler gauge. The gauge must drag a little when being slid between the electrodes.

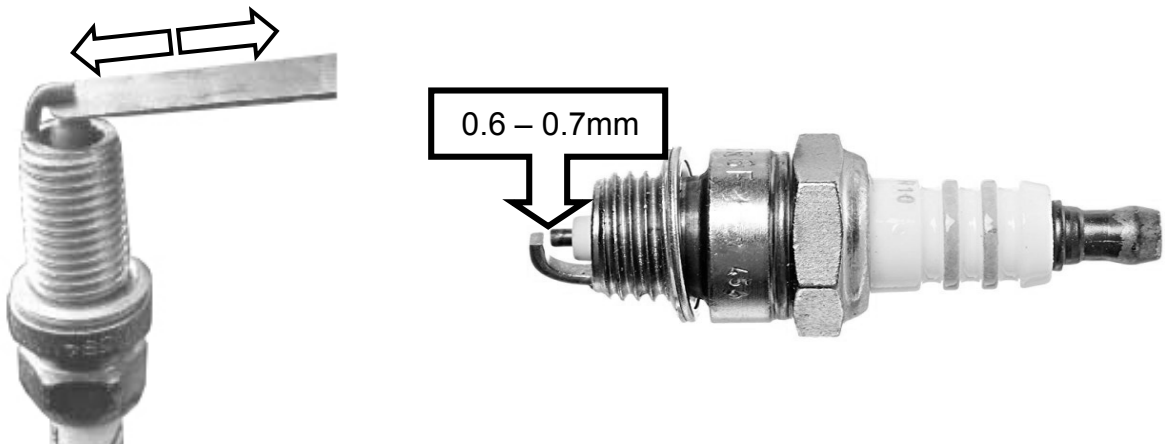

- 7.23 Refit the spark plug by hand to avoid cross threading.
- 7.24 Once the spark plug seats, tighten the spark plug to a torque of 12 – 15Nm.

## SPARK ARRESTER

- 7.25 The spark arrester must be maintained every 100 hours of use.
- 7.26 Remove the exhaust guard screws and remove the guard.
- 7.27 Remove the spark arrester.
- 7.28 Remove carbon deposits from the spark arrester with a soft wire brush. If the spark arrester is worn, replace it.
- 7.29 Reinstall the spark arrester and exhaust guard.

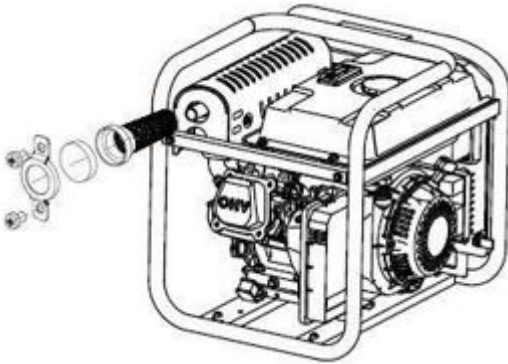

## 8. STORAGE & TRANSPORTATION



### CAUTION

Always allow the machine to cool completely before transportation or storage.

### TRANSPORTATION

- 8.0 Drain the fuel tank using a siphon or similar fuel retrieval device.
- 8.1 Store the fuel in a suitable container for transport.
- 8.2 Ensure the fuel tap is in the OFF position.
- 8.3 Ensure the ignition switch is in the OFF position.
- 8.4 Secure the machine upright in the vehicle so it cannot move during transportation.
- 8.5 Do not use the machine whilst in the vehicle.
- 8.6 Fuel and its vapours are highly flammable, keep the generator away from any possible sources of ignition.



### NOTE

If the machine is to be stored for periods of 30 days or more then it is essential to prepare the machine for storage correctly. Failure to do so could result in issues making the machine difficult to start or cause poor running.



### DANGER

The machine must be allowed to cool completely before storage.

- 8.7 Drain the fuel tank using a siphon or similar fuel retrieval device, into a suitable container.
- 8.8 Run the engine under no load until the machine stops to remove any remaining fuel from the carburettor and fuel lines.
- 8.9 Allow the engine to cool completely.
- 8.10 Drain the engine oil from the engine following the procedure laid out in the maintenance section of this manual.
- 8.11 Refill with fresh engine oil.
- 8.12 Clean the area around the spark plug and remove the spark plug following the procedure laid out in the maintenance section of this manual.
- 8.13 Pour a teaspoon of fresh engine oil into the spark plug hole into the cylinder bore.
- 8.14 Gently pull the recoil starter handle 4 to 5 times to coat the cylinder bore with a layer of fresh engine oil.
- 8.15 Refit the spark plug but leave the spark plug HT lead cap removed.
- 8.16 Clean the machine using a brush to remove large pieces of debris and a moist cloth for other areas.
- 8.17 **DO NOT** use a pressure washer or hose pipe to clean the machine. Water could penetrate the engine causing serious damage.
- 8.18 **DO NOT** use solvent based cleaning products as these could damage plastic parts and components.
- 8.19 Check the tightness of all nuts, bolts and screws.
- 8.20 Use a silicone based grease to lubricate any moving parts.
- 8.21 Store upright in a cool dry place away from extremes of temperature change and away from any possible sources of ignition.
- 8.22 **DO NOT** store other items on top of the machine.

## 9. TROUBLESHOOTING



### NOTE

If troubleshooting does not resolve your issue, then please contact your dealer.

Problem	Possible Cause	Possible Solution
Engine will not start – Fuel System	Choke open	Move choke lever to the closed position
	Fuel tank empty	Add fuel
	Machine stored incorrectly	Check and clean fuel tank and fuel lines
	Water in fuel system	Drain and fill with fresh fuel
	Carburettor problem	Contact your dealer
Engine will not start – Spark Plug	Incorrect spark plug	Replace with correct spark plug
	Dirt or carbon build up on electrode	Clean electrode or replace plug
	Spark plug short circuit	Replace spark plug
	Incorrect plug gap	Check and re-gap spark plug
	Petrol/oil on spark plug	Clean spark plug, Start with full throttle
Engine will not start – Low compression	Serious internal engine damage of faulty valves	Contact your dealer
Engine lacks power/runs unevenly – Air Filter	Clogged air filter	Clean or replace air filter
Engine lacks power/runs unevenly – Fuel System	Machine stored incorrectly with regards to emptying the fuel system	Check and clean the fuel tank, carburettor and fuel lines for sludge. Refill with fresh petrol.

## 10. SPECIFICATION

<b>HY3000CI</b>	
Engine Type	4-Stroke OHV, Forced-Air Cooling
Frequency Hz	50
Voltage - V	230
Current - A	13
Max Power - kW	3.0
Displacement - cc	208
Max Speed	3600rpm
Compression Ratio	8:2:1
Ignition System	Full Transistor
Start Method	Recoil
Fuel Type/Tank Capacity - L	Unleaded Petrol / 6.5Litres
Engine Oil Capacity - L	0.6
Engine Oil	SAE10W30 or 15W40
Bore Stroke	70.0mm*54.0mm
Continuous Running Time - Hr	3.7 (75% Load)
Noise Level – dB(A) @ 7m	72*
Dimensions (LxWxH) - mm	400x480x450
Net Weight - kg	30



## 11. RECYCLING & PRODUCT DISPOSAL

- 11.0 We do not offer a take back scheme for the recovery of Waste Electrical Electronic Equipment (WEEE) & Batteries.  
Instead the responsibility to dispose of WEEE and or batteries is passed onto you by us.  
So when it becomes necessary to dispose of your machine you must take it to your Local Civic Amenity Site.  
For further information please contact your Local Authority for disposal advice.
- 11.1 You MUST make sure that all unused oil and fuel is disposed of correctly either beforehand or at your Local Civic Amenity Site.  
Under NO circumstances must any fuel or oil be put down any drains.
- 11.2 Certain products contain WEEE waste which should not be disposed of in your domestic waste.
- 11.3 You MUST recycle WEEE in accordance with your local authority or recycling centre.
- 11.4 Certain products contain batteries which should not be disposed of in your domestic waste.
- 11.5 You MUST recycle batteries which should not be disposed of in your domestic waste.
- 11.6 Unwanted packaging and materials should be stored and taken to a recycling centre so it can be disposed of in a manner which is compatible with the environment.
- 11.7 The following symbol means you should 'Reduce – Reuse - Recycle'.
- 11.8 We are a member of VALPAK National Compliance Scheme and our registration number is RM08660.
- 11.9 For further information about disposal please contact your Local Authority.
- 11.10 You can also get more advice and guidance about recycling at the following website <http://recycle-more.co.uk>
- 11.11 Should you pass this product on to another user either sold or loaned, you MUST pass on this user manual.  
This will make sure that all other users can use and maintain this machine safely.

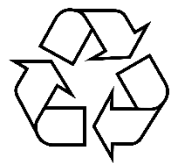
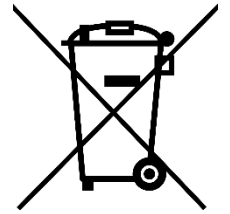

## 12. DECLARATION OF CONFORMITY

12.0 Genpower Ltd confirms that this Hyundai product conforms to the following CE Directives;  
2006/42/EC Machinery Directive  
2004/108/EC EMC Directive  
2000/14/EC Amended by 2005/88/EC Noise Emissions Directive  
97/68/EC 2010/26/EC NRMM Emissions Directive

### EC DECLARATION OF CONFORMITY

The undersigned. As authorised by: **Genpower Ltd**  
Declares that the following equipment manufactured under licence by Hyundai Korea

Conforms to the Directive:-  
**2000/14/EC (as amended)**

Of the European Parliament and of the council on the approximation of the laws of the Member States relating to the noise emission in the environment by equipment for the use outdoors.

Equipment Category: **Petrol Driven Generator**  
Product Name/Model: **HY3000CI**  
Type/Serial No: **Generator**  
Net installed power: **210cc**  
The technical documentation is kept by: **Roland Llewellyn, Genpower Ltd  
Isaac Way, Pembroke Dock,  
Pembrokeshire, SA72 4RW.**

The conformity assessment procedure followed was in accordance with annex V of the Directive.

Notified Body: **Grand-Duche De Luxembourg  
Ministere du Developpement Durable  
et des Infrastructures L-2938 Luxembourg  
Certification n° e13\*2016/1628\*2017/656SRA1/P\*0081\*0**

Measured Sound Power Level: **96dB**

Guaranteed Sound Power Level: **96dB**

A copy of this certificate has been submitted to the European Commission and the EU Member State United Kingdom.

Place of Declaration: **Pembroke Dock, SA73 4RW**

Date: **07/03/2018**

Signed by: **Roland Llewellyn**



Position in Company: **Managing Director**

Name and address of manufacturer or Authorised representative:

**Genpower Ltd  
Isaac Way, Pembroke Dock,  
Pembrokeshire, SA72 4RW**

## 13. CONTACT DETAILS

13.0	CONTACT DETAILS	Genpower Ltd, Isaac Way, London Road, Pembroke Dock, Pembrokeshire SA72 4RW. UK.
13.1	FAX	+44 (0) 1646 686198
13.2	SUPPORT	<a href="mailto:aftersales@genpwer.co.uk">aftersales@genpwer.co.uk</a>
13.3	WEBSITE	<a href="http://www.hyundaipowerequipment.co.uk">www.hyundaipowerequipment.co.uk</a>

## 14. WARRANTY

- 14.0 To register your product for the manufacturer's warranty, please visit:  
[www.hyundaipowerequipment.co.uk/warranty](http://www.hyundaipowerequipment.co.uk/warranty)
- 14.1 For full warranty terms and conditions, please visit:  
[www.hyundaipowerequipment.co.uk/support/warranty-information](http://www.hyundaipowerequipment.co.uk/support/warranty-information)

## 15. MANUAL UPDATES

- 15.0 Our manuals are constantly being reviewed and updated. However if you find an error, omission or something you find unclear, please contact your dealer for assistance.
- 15.1 Our latest manuals are also placed online.

# **HYUNDAI**

**POWER PRODUCTS**

**For Inquiries, Please Contact:**

**GENPOWER LTD**

Isaac Way, London Road

Pembroke Dock, UNITED KINGDOM, SA72 4RW

T: +44 (0) 1646 687 880 F: +44 (0) 1646 686 198

E: [info@hyundaipowerequipment.co.uk](mailto:info@hyundaipowerequipment.co.uk)

[www.hyundaipowerequipment.co.uk](http://www.hyundaipowerequipment.co.uk)