

HYUNDAI
POWER PRODUCTS

60V BATTERY POWERED LAWNMOWER HYM60Li420

User Manual

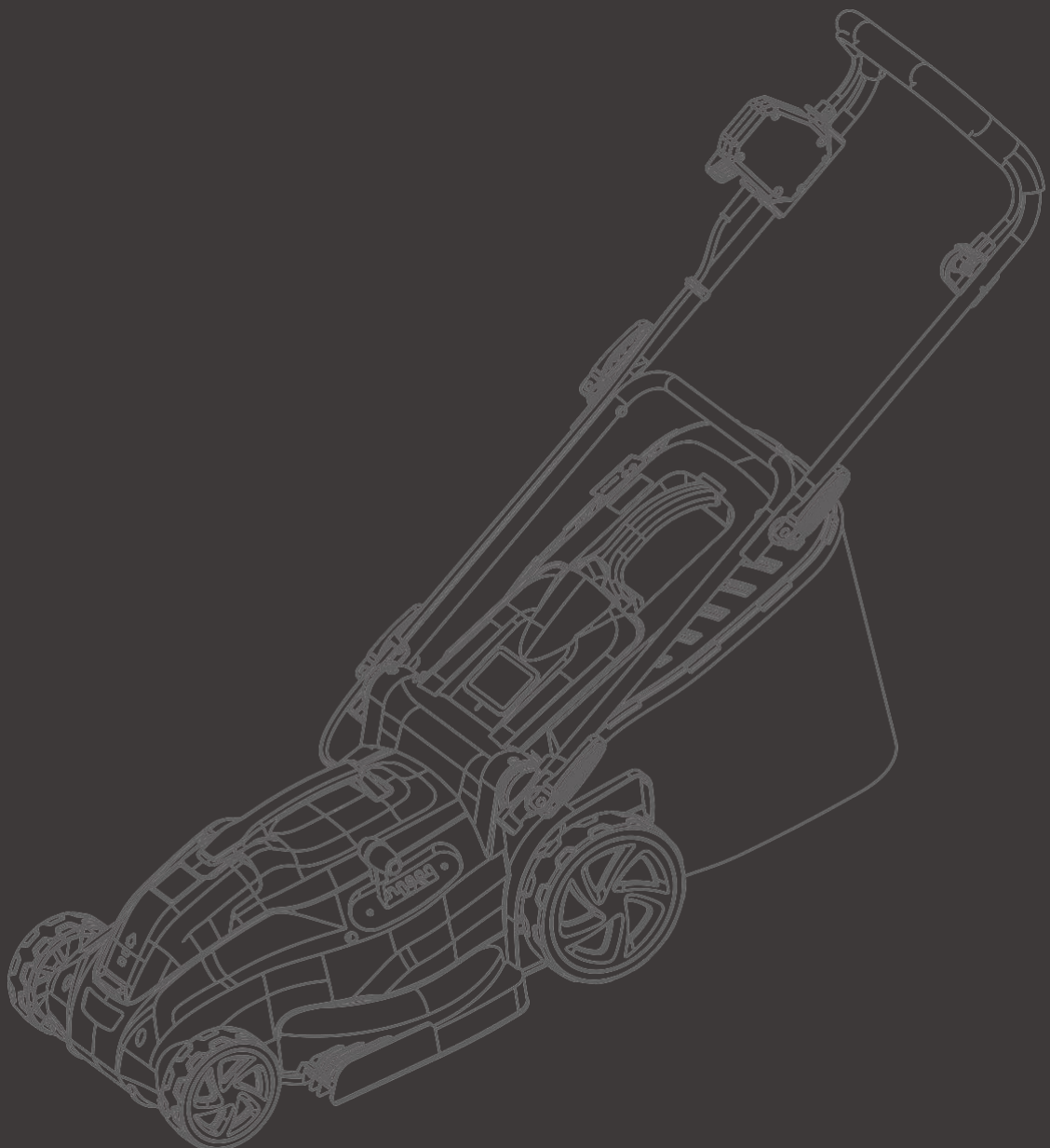

Contents

General power tool safety warnings	03
Safety instructions.....	05
Handling.....	06
Additional safety points.....	08
Battery and charger safety instructions	09
Information about the battery	12
Information about the charger and the charging process.....	13
Symbols.....	16
Diagram.....	18
Parts list	19
Intended use	20
Assembly.....	21
Handle assembly.....	21
Grass collection bag assembly and fitting.....	22
Adjusting the cutting height.....	23
Battery pack operation.	23
Installing and charging the battery	23
Operation.....	24
Powering on and off.	25
Grass bag filling level indicator.....	26
Mowing tips	26
Cleaning and maintenance.	28
Cleaning.....	28
Servicing.....	28
Replacing the mower blade	28
Ordering replacement parts	28
Technical data.....	30
Troubleshooting.....	31
Recycling and disposal	31
Recycling and disposal	32
Contact Information	32
Warranty.....	32
Declarations of conformity.....	33

General power tool safety warnings

General power tool safety warnings



WARNING Read all safety warnings and all instructions.

Failure to follow the warnings and instructions may result in electric shock, fire and/or serious injury.



WARNING! Read all safety warnings designated by the symbol and all instructions. Save all warnings and instructions for future reference.

The term 'power tool' in the warnings refers to your mains-operated (corded) power tool or battery-operated (cordless) power tool.

- a. Keep the work area clean and well-lit – cluttered, dark areas invite accidents.
- b. Keep children, bystanders and pets away – always keep children and spectators a safe distance away from the mower during operation and as the machine cools. Children must always be supervised to ensure that they do not play with the equipment.
- c. Dress properly – always wear personal safety gear (e.g. safety glasses, rubber gloves, protective non-slip footwear and dust masks) and proper clothing when using the mower. Loose clothing, long hair or jewellery may get caught in the moving parts.
- d. Use the right appliance – do not use the lawn mower for any purposes other than those for which it is intended.
- e. Do not force the lawn mower – it will perform better with less likelihood of personal or mechanical injury if it is used in the way in which it is designed.
- f. **CAUTION:** Sharp blades! Remove the battery before carrying out any repair work. The blades will

General power tool safety warnings

General power tool safety warnings (continued)

continue to rotate after the motor is switched off.

- g. Stay alert – always stay alert and watch what you are doing. Use common sense. Do not operate the lawn mower when you are tired or under the influence of alcohol or drugs. This lawn mower is not designed to be used by people (including children) with limited physical, sensory or mental capacities. It should also not be used by those lacking the proper experience and/or knowledge unless they are supervised by a person who is responsible for their safety or they have received instructions from such a person on how to safely use the mower.
- h. Store idle lawn mower indoors – when not in use, the lawn mower should be stored indoors in a dry, locked place, out of the reach of children.
- i. Maintain the lawn mower with care – keep cutting edges sharp and clean to maximise your mower's performance and ensure operator safety. Keep handles dry, clean and free from oil and grease.
- j. Moving parts present risks – keep your face, hair, clothing, hands and feet away from all moving parts. All guards and safety attachments must be installed properly before using the unit. Shut off and disconnect the battery before touching any parts other than the handles and the switch.
- k. Cutting/dismemberment hazard of hand – do not touch the cutters until the battery has been disconnected from the mower and the cutters have reached a complete standstill.
- l. Avoid unintentional starting – make sure the safety

General power tool safety warnings

General power tool safety warnings (continued)

switch and the switch bar lever are in the OFF position before inserting the battery into the unit. Do not carry the lawn mower with the safety switch and the switch bar lever engaged.

- m. Do not overreach – maintain proper footing and balance at all times. Place heels firmly on the ground and tightly grasp the handle bar. Watch for uneven surfaces and do not overreach. In case you fall or collide with the lawn mower, inspect the unit for any damages or cracks. When stepping backwards, be careful to avoid obstacles beneath your feet or behind you to avoid falling.

WARNING! If the lawn mower strikes any object, follow these steps:

- i) Stop the lawn mower. Remove the battery.
- ii) Inspect for damage.
- iii) Repair any damage before restarting and operating the lawn mower.

Safety instructions

General operation

Read, understand and follow all the safety regulations and instructions on the machine and in the manual before starting.

- Only responsible adults who are thoroughly familiar with the operator controls and the operation of the machine should be allowed to use the mower.
- Make sure that the mowing area is clear of children, pets and other bystanders before starting the machine. Stop the machine if anyone enters the area.

General power tool safety warnings

Safety instructions

- Do not tip the machine when starting. The machine should be on level ground and you should have a firm grasp on the handle when powering ON.
- Disconnect the power supply (e.g. remove the battery) in the following situations:
 - i) whenever you leave the machine unattended;
 - ii) before releasing a blocked cutter;
 - iii) before inspecting, cleaning or performing other maintenance on the machine;
 - iv) if a foreign body has been struck;
 - v) whenever the machine starts to vibrate oddly.
- Never mow in the direct vicinity of persons – especially children – or animals.
- Do not operate the machine barefooted or while wearing sandals. Always wear substantial footwear.
- Check the ground on which the equipment will be used and remove all objects that could be picked up and violently flung by the rotary mower blade.
- Before using the mower, visually inspect it to ensure that the blade, mounting bolts and the entire cutting apparatus are in proper working order (e.g. not worn or damaged). To prevent any operating imbalance, replace worn or damaged blades and mounting bolts as a set only (if applicable).

Handling

- Only mow in broad daylight or under well-lit conditions.
- Avoid dangerous environments. Do not use the mower in the rain or on damp/wet grass.
- Always maintain good footing on inclines.

General power tool safety warnings

Handling (continued)

- Only operate the mower at a walking pace.
- Always mow across hills (e.g. never straight up or straight down).
- Be particularly careful when you change direction on a slope.
- Do not mow on overly steep inclines.
- Take extra caution when turning the mower around and when pulling it towards you.
- Switch the mower off, remove the battery and wait until the cutters have reached a complete standstill when tipping the mower over, transporting it over surfaces other than grass, and when moving the mower to and from the area you wish to mow.
- Never use the lawn mower if the guards (e.g. grass-catching devices) are damaged or not properly fitted.
- Use the ON/OFF switch carefully as described in the manufacturer's instructions. Make sure that your feet are far enough away from the mower blade when starting and using the mower!
- The lawn mower should not be tilted when the motor is switched on unless it has to be raised for starting purposes. In this case, tilt it as little as absolutely necessary and only raise the side opposite to that of the user.
- Do not switch on the mower if you are positioned in front of the discharge chute.
- Never move your hands or feet toward or under any rotating parts. Keep clear of the discharge chute opening at all times.
- Never lift or carry a lawn mower with the engine running.

General power tool safety warnings

Handling (continued)

- Switch off the motor, remove the battery and wait for the rotating blades to stop completely: before you dislodge any blockages or clogs in the discharge chute or mower deck; before carrying out any checks, cleaning, maintenance or other work on the lawn mower; and immediately after striking a foreign object. Examine the mower for signs of damage and carry out any necessary repairs before restarting and continuing to work with the mower. If the lawn mower starts to vibrate oddly, immediately switch it off and inspect it.
- Switch off the mower and remove the battery whenever you leave the mower.

Additional safety points

- Make sure that all nuts, bolts and screws are tightened securely and that the machine is in safe working condition.
- Allow the mower to cool before you put it into an enclosed area.
- To avoid the risk of fire, keep the motor housing and ventilation slots clear of grass, leaves, oil and grease.
- Routinely check the grass basket for signs of wear and impaired functionality.
- For your own safety, have worn or damaged parts immediately replaced.
- Take care not to jam your fingers between moving blades and stationary parts of the equipment while you are adjusting the equipment.
- While you are carrying out maintenance work on the blades, remember that the blades can still be moved even if the power source has been switched off.

Battery and charger safety instructions

We pay a great deal of attention to the design of every battery pack to ensure that we supply you with batteries that are safe, durable and have a high energy density. The battery cells have a wide range of safety devices.

Despite all the safety precautions, caution must always be exercised when handling batteries. The following points must be obeyed at all times to ensure safe use. Safe use can only be guaranteed if undamaged cells are used. Incorrect handling of the battery pack can cause cell damage.

IMPORTANT! Analysis confirms that incorrect use and poor care of high-performance batteries are the two main factors responsible for personal injury and/or product damage.

WARNING! Use only approved replacement batteries; other batteries may damage the lawn mower and cause it to malfunction, which can lead to serious personal injury.

- Avoid dangerous environments – do not charge the battery pack in rain, snow or in damp or wet conditions. Do not use the battery pack or charger in the presence of explosive atmospheres (gaseous fumes, dust or flammable materials) because sparks may be generated when inserting or removing the battery pack, which could lead to a fire.
- Charge in a well-ventilated area – do not block the charger vents. Keep them clear to allow for proper ventilation. Do not allow smoking or open flames near a

Battery and charger safety instructions

charging battery pack. Vented gases may explode.

- Maintain charger cord – when unplugging the charger pull the plug, not the cord, from the receptacle to reduce the risk of damage to the electrical plug and cord. Never carry the charger by its cord or yank it by the cord to disconnect it from the receptacle. Keep the cord away from heat, oil and sharp edges. Make sure the cord will not be stepped on, tripped over or subjected to damage or stress when the charger is in use. Do not use the charger with a damaged cord or plug. Replace a damaged charger immediately.
- Use only recommended attachments – use of an attachment not recommended or sold by the battery charger or battery pack manufacturer may result in risk of fire, electric shock or personal injury.
- Unplug the charger when not in use – make sure to remove battery packs from unplugged chargers.

WARNING! To reduce the risk of electric shock, always unplug the charger before performing any cleaning or maintenance. Do not allow water to flow into the AC/DC plug. Use a Ground Fault Circuit Interrupter (GFCI) to reduce shock hazards.

- Do not burn or incinerate battery packs – battery packs may explode, causing personal injury or damage. Toxic fumes and materials are created when battery packs are burned.
- Do not crush, drop or damage battery packs – do not use the battery pack or charger if they have sustained

Battery and charger safety instructions

a sharp blow, been dropped, run over or have been damaged in any way (e.g. pierced with a nail, hit with a hammer, stepped on, etc.).

- Do not disassemble – incorrect reassembly may pose a serious risk of electric shock, fire or exposure to toxic battery chemicals.
- Battery chemicals cause serious burns – never let a damaged battery pack contact the skin, eyes or mouth. If a damaged battery pack leaks battery chemicals, use rubber or neoprene gloves to safely dispose of it. If skin is exposed to battery fluids, wash the affected area with soap and water and rinse with vinegar. If eyes are exposed to battery chemicals, immediately flush with water for 20 minutes and seek medical attention. Remove and dispose of contaminated clothing.
- Do not short circuit – a battery pack will short circuit if a metal object makes a connection between the positive and negative contacts on the battery pack. Do not place a battery pack near anything that may cause a short circuit, such as paper clips, coins, keys, screws, nails and other metallic objects. A short circuited battery pack poses a risk of fire and severe personal injury.
- Store your battery pack and charger in a cool, dry place – do not store the battery pack or charger where temperatures may exceed 40 °C, such as in direct sunlight or inside a vehicle or metal building during the summer.

Battery and charger safety instructions

Information about the battery

1. The battery pack supplied with your cordless lawn mower is not charged. The battery pack has to be charged before you use the tool for the first time.
2. For optimum battery performance avoid low discharge cycles. Charge the battery pack frequently.
3. Store the battery pack in a cool place, ideally at 59°F (15°C) and charged to at least 40%.
4. Lithium-ion batteries are subject to a natural aging process. The battery pack must be replaced when its capacity falls to 80% of its capacity (at the latest). Weakened cells in an aged battery pack are no longer capable of meeting the high power requirements needed for the proper operation of your lawn mower, and therefore pose a safety risk.
5. Do not throw battery packs into an open fire. There is a risk of explosion!
6. Do not ignite the battery pack or expose it to fire.
7. Do not exhaustively discharge batteries. Exhaustive discharge will damage the battery cells. The most common cause of exhaustive discharge is lengthy storage or non-use of partially discharged batteries. Stop working as soon as the performance of the battery falls noticeably, or the electronic protection system triggers. Place the battery pack in storage only after it has been fully charged.
8. Protect batteries and the tool from overloads. Overloads will quickly result in overheating and cell damage inside the battery housing, even if this overheating is not apparent externally.
9. Avoid damage and shocks. Immediately replace

Battery and charger safety instructions

Information about the battery(continued)

batteries that have been dropped from a height of more than one metre or those that have been exposed to violent shocks, even if the housing of the battery pack appears to be undamaged. The battery cells inside the battery may have suffered serious damage.

10. If the battery pack suffers overloading and overheating, the integrated protective cut-off will switch off the equipment for safety reasons.

IMPORTANT! Do not press the ON/OFF switch if the protective cut-off has been activated. This may damage the battery pack.

11. Use original battery packs only. The use of other batteries poses a fire risk and may result in injuries or an explosion.

Information about the charger and the charging process

1. Please check the data marked on the rating plate of the battery charger. Be sure to connect the battery charger to a power supply with the voltage marked on the rating plate. Never connect it to a different mains voltage.
2. Protect the battery charger and its cord from damage. Keep the charger and its cord away from heat, oil and sharp edges.
3. Electrical plugs must match the outlet. Never modify the plug in any way. Do not use any adapter plugs with grounded appliances. Unmodified plugs and matching outlets will reduce the risk of electric shock.
4. Keep the battery charger, battery and the cordless tool

Battery and charger safety instructions

Information about the charger and the charging process

out of the reach of children.

5. Do not use the supplied battery charger to charge other cordless tools.
6. During periods of heavy use, the battery pack will become warm. Allow the battery pack to cool to room temperature before inserting it into the charger to recharge.
7. Do not over-charge batteries. Do not exceed the maximum charging times. These charging times only apply to discharged batteries. Frequent insertion of a charged or partially charged battery pack will result in over-charging and cell damage. Do not leave batteries in the charger for days on end.
8. Never use or charge a battery if you suspect that it has been more than 12 months since the last time it was charged. There is a high probability that the battery pack has already suffered dangerous damage (exhaustive discharge).
9. Charging batteries at a temperature below 50°F (10°C) will cause chemical damage to the cells and may cause a fire.
10. Do not use batteries that have been exposed to heat during the charging process, as the battery cells may have suffered dangerous damage.
11. Do not use batteries that have suffered curvature or deformation during the charging process or those that exhibit other atypical symptoms (e.g. gassing, hissing, cracking, etc.)
12. Never fully discharge the battery pack (maximum recommended depth of discharge is 80%). A complete

Battery and charger safety instructions

Information about the charger and the charging process

discharge of the battery pack will lead to premature aging of the battery cells.

The light in the charger indicate information

1.Red light is on, green light off	Connected to socket, ready for charging
2. Red light in on, green is blinking	battery is charging
3.Red light is off, green light is on	battery is full
4. red light and green light is alternate blinking	battery is overheated
5.Red light is blinking, green light is off	battery is malfunction

Symbols

Warnings symbols



Indicates danger, warning or caution.



WARNING – To reduce the risk of injury, user must read instruction manual.



Severing of toes or fingers by rotary mower blade.



CAUTION! Objects picked up and thrown by the rotating blade can cause severe injury.



WARNING! Always turn the machine OFF and remove the safety key before conducting an inspection, cleaning and maintenance.



Keep bystanders away.



Conforms to relevant safety standards.



This class II symbol indicates that the product is correctly insulated. Grounding this machine is therefore unnecessary.



Recycle unwanted materials instead of disposing of them as waste. All tools, hoses and packaging should be sorted, taken to the local recycling centre and disposed of in an environmentally safe way.



Guaranteed sound power level (tested according to Directive 2000/14/EC as amended by 2005/88/EC).



Wear gloves to protect your hands, wear safety shoes.

Symbols

Warnings symbols



For dry indoor use only.



Do not expose battery packs to heat in excess of 50°C.



Do not dispose of battery packs in fire. They will explode and cause injury.



Do not dispose of battery packs in rivers or immerse in water.



Batteries and battery packs should not be disposed of with household waste. Please recycle where facilities exist. Check with your local authority for recycling advice.

Li-ion

Diagram

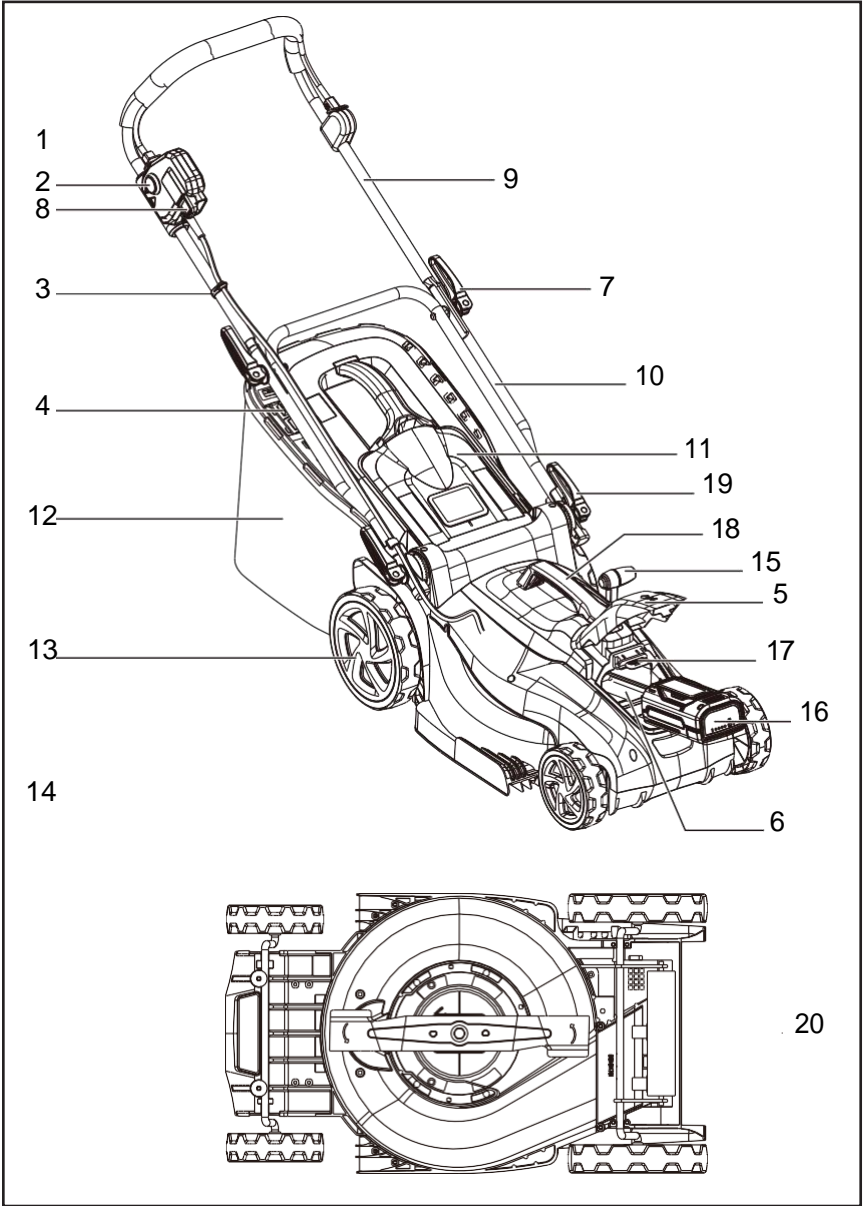

Parts list

1.	Switch bar lever
2.	Safety switch button
3.	Cable clip
4.	Grass indicator window
5.	Battery cover
6.	Battery compartment
7.	Upper handle quick clip
8.	Safety key
9.	Upper handle
10.	Lower handle
11.	Ejector flap
12.	Grass bag
13.	Rear wheel
14.	Front wheel
15.	Cutting height adjustment lever
16.	Battery
17.	Battery lock button
18.	Carry handle
19.	Lower handle quick clip
20.	Blade

Intended use

Carefully follow the instructions on the pages that follow to assemble your cordless lawn mower.

The equipment may only be used for the tasks it is designed to handle. Any other use is deemed to be a case of misuse. The user/operator, not the manufacturer, will be liable for any damage or injuries of any kind resulting from such misuse of the mower. The lawn mower is intended for private residential use (e.g. for use in home and gardening environments). Private use of the lawn mower refers to an annual operating time generally not exceeding 50 hours, during which the machine is primarily used to maintain small-scale, residential lawns and home/hobby gardens. Public facilities, sporting halls and agricultural/forestry applications are excluded. Please note that this equipment has not been designed for commercial, trade or industrial applications. The warranty will be voided if the machine is used in commercial, trade or industrial businesses or for equivalent purposes.

Keep these instructions and refer to them prior to each mowing session in order to ensure that the lawn mower is properly used and maintained. The instructions contain valuable information on operating, maintenance and servicing.

Reduce noise generation and keep vibration to a minimum!

- Use only equipment that is in perfect condition.
- Maintain and clean the equipment regularly.
- Adjust your work rate to the equipment's performance.
- Do not overload the equipment.
- Have the equipment checked if necessary.
- Switch off the equipment when not in use.
- Wear gloves.

Assembly

Handle assembly

1. Adjust the lower handle to the correct position for comfortable height, by aligning the line on the mower body with one of the three lines on the end of the lower handle. Fit the quick clips through the lower handle, and tighten (See Fig. 1).

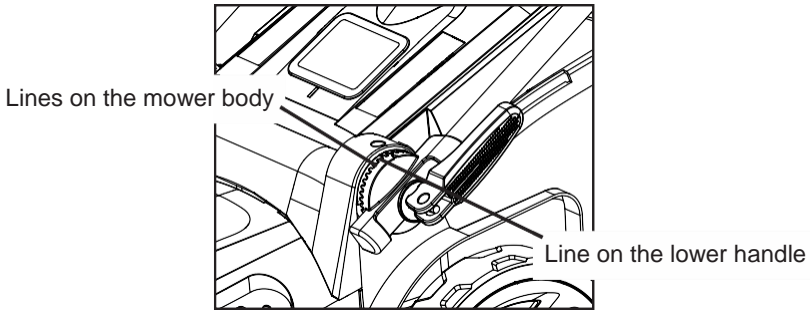

Fig. 1



WARNING! The line on the mower body must be aligned with one of the lines on the lower handle. And, the same line must be used for both sides of the unit.

2. Place the upper handle over the upper ends of the lower handle. Align the holes. Use the two sets of upper handle clips to secure (See Fig. 2).

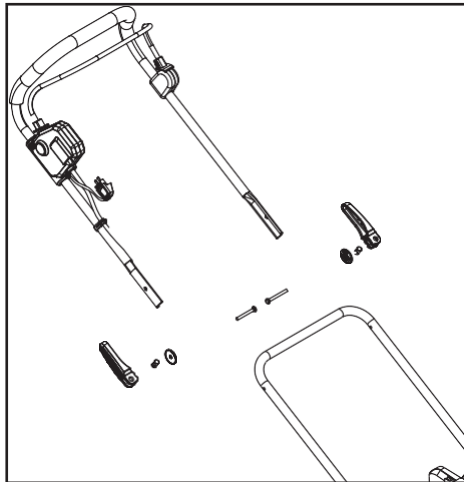

Fig. 2

Assembly

Handle assembly (continued)

3. Secure the power cable to the lawn mower using the cord clip (See Fig. 3).

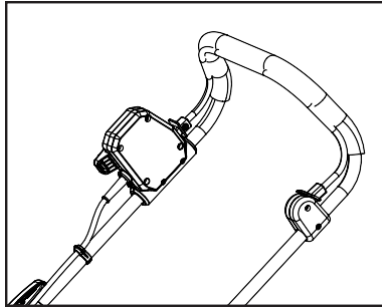

Fig. 3

Grass collection bag assembly and fitting

1. Insert the grass collection bag handle into the holes on the top of grass collection bag until it clicks in (See Fig. 4).

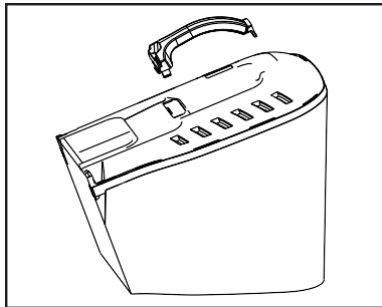

Fig. 4

2. Lift the ejector flap with one hand. With the other hand, hold the grass collection bag by the handle and hook it in from above (See Fig. 5).

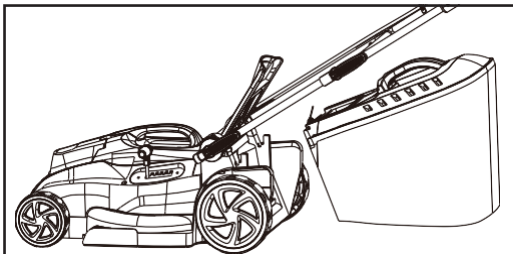

Fig. 5

Assembly

Adjusting the cutting height



IMPORTANT! Before adjusting the cutting height, make sure the motor is switched off and the safety key has been pulled out.

To set the cutting height on your lawn mower, pull out the cutting height adjustment lever, move the lever to the left or right and push it back into one of the six cutting positions indicated below. Make sure that the lever engages properly (See Fig. 6).

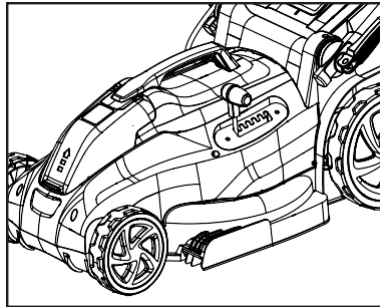

Fig. 6

6-position height adjustment:

- | | |
|------------------------|------------------------|
| 1. 0.79 inches. (20mm) | 4. 1.97 inches. (50mm) |
| 2. 1.18 inches. (30mm) | 5. 2.36 inches. (60mm) |
| 3. 1.57 inches. (40mm) | 6. 2.76 inches. (70mm) |

Battery pack operation

The equipment is fitted with a lithium-ion battery. The battery pack is completely closed and maintenance free.

Battery pack operation

The battery pack is equipped with a push button for checking the charge level. Simply press the push button to read off the battery charge level from the LEDs of the battery indicator:

- All 3 level monitoring LEDs are lit: battery charge level is high.
- 2 level monitoring LEDs are lit: battery charge level is decreasing. Stop work as soon as possible.
- 1 level monitoring LED is lit: battery is flat. Stop work **IMMEDIATELY** and charge the battery. Otherwise the battery's service life will be greatly shortened.

Installing and charging the battery

1. Open the battery cover on the lawn mower.
2. Press the lock button on the mower to pull the battery pack up and out of the battery compartment.

Battery pack operation

Installing and charging the battery

3. Check that the mains voltage is the same as that marked on the rating plate of the battery charger. Then, insert the charger's plug into the electrical wall outlet. When you plug in the charger, the top green light will illuminate and stay green.
4. Place the battery pack into the charger. When you insert the battery into the charger, the bottom red light will illuminate to indicate that the battery is charging.
5. When the bottom light turns green, the battery is fully charged.
6. The battery charge indicator lights on the battery pack will display as the pack is charging to indicate the battery's capacity.
7. After charging is complete, the continuous green light will turn on and the charge level indicator on the battery will turn off.
8. If the charging light indicator alternately blinks red and green or the light indicator does not come on at all, check that the battery pack is fully seated into the charger.
9. When charging is complete, remove the battery from the charger.
10. Timely recharging of the battery will help prolong the battery's life. You must recharge the battery pack when you notice a drop in the equipment's power.



IMPORTANT! Never allow the battery pack to become fully discharged as this will cause irreversible damage to the battery.

Operation



IMPORTANT! The lawn mower is equipped with a safety circuit to prevent unauthorised use. Directly before starting up the lawn mower, insert the safety key into the slot found on the switch box (See Fig. 7) and remove the safety key again whenever you interrupt or terminate your work.

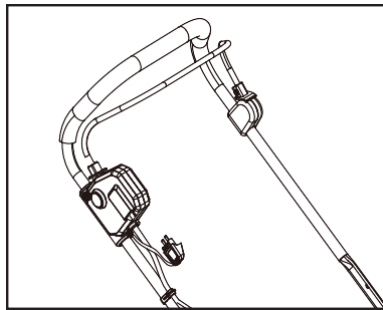

Fig. 7

To prevent the equipment switching on accidentally, the lawn mower is equipped with a safety switch button, which must be pressed before the ON/OFF switch bar lever can be activated.

Operation

Powering on and off

1. Open the battery compartment cover and slide the battery to lock it into position (See Fig. 8).

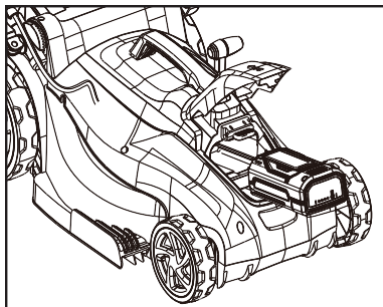

Fig. 8

2. Close the battery compartment cover.
3. Insert the safety key into the slot. To power on, press and hold the safety lock button while pulling the switch bar lever towards you (See Fig. 9). Once the machine powers on, release the safety lock button and proceed with operation. The lawn mower can only be started by pressing the safety switch button first, followed by squeezing the ON/OFF switch bar lever; reverse operation will not start the machine.

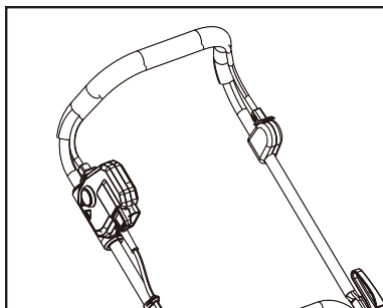

Fig. 9

4. To power off, release the ON/OFF switch bar lever.

Operation

Grass bag filling level indicator

1. The grass bag is equipped with a filling level indicator window that is opened by the airflow that the lawn mower generates during operation (See Fig. 10).

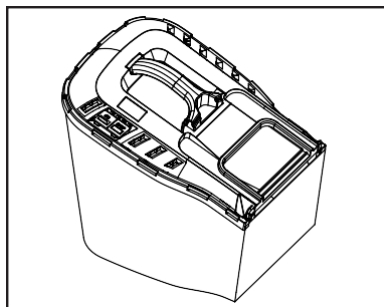

Fig. 10

2. If the flap closes during mowing, this indicates that the grass bag is full and must be emptied.

Note: To ensure that the filling level indicator functions properly, keep the holes under the flap clean and permeable.

Mowing tips



IMPORTANT! Inspect the area prior to mowing and remove all the stones, sticks, wires and other foreign objects that could be picked up and thrown by the rotating blade. Failure to comply not only will damage the mower blade, but can also lead to serious personal injury.

- Be sure to check the mowing blade periodically for signs of wear and sharpen it at least once per year, as described in the maintenance section.

Note: A sharp blade will greatly enhance the performance of the mower, especially when cutting tall blades of grass.

- When cutting thick grass, reduce your walking speed in order to allow for a more effective cut and an effective discharge of the clippings. For a healthy lawn, always cut off one-third or less from the total length of the grass. The average lawn should be approximately 1.5 - 2" (3.8 - 5cm) long during cool months, and more than 2" (5cm) long during hot months. If there is growth, the lawn should be cut in the Autumn.
- The lawn will look better if it is always cut to the same height and in alternate directions. When crossing any graveled surfaces, release the switch bar lever to turn off the mower. The stones can be picked up and thrown by the rotating blade.
- Set the mower to the highest cutting height when mowing on uneven ground or in tall weeds.

Operation

Mowing tips (continued)



WARNING! If you strike a foreign object, stop the motor and remove the safety key. Thoroughly inspect the mower and repair any damage before resuming work.

- **IMPORTANT!** Never open the ejector flap when the grass bag has been detached (to be emptied) and the motor is still running. A rotating blade can cause serious injuries!
- Always carefully fasten the ejector flap and grass bag. Switch off the motor before emptying the grass bag. Always ensure that a safe distance (provided by the length of the long handles) is maintained between the user and the mower housing. Be especially careful when mowing and changing direction on slopes and inclines.
- Maintain a solid footing and wear sturdy, non-slip footwear and long trousers. Always mow across an incline (not up and down).
- For safety reasons, the lawn mower may not be used to mow inclines with gradients exceeding 15 degrees.
- Use special caution when backing up and pulling the lawn mower towards you, as such maneuvering of the machine poses a tripping hazard.

Cleaning and maintenance

Cleaning



WARNING! Before cleaning, repairing, inspecting or carrying out any other maintenance work, ensure that the blade is not rotating and that the safety key has been disconnected.

- Keep all safety devices, air vents and the motor housing free of dirt and dust as much as possible.
- Wipe the equipment with a clean cloth or blow it with compressed air at low pressure.
- Clean the equipment immediately after use with a damp cloth and some soft, non-abrasive soap. Do not use cleaning agents or harsh solvents; these may damage the plastic parts in the equipment. Ensure that no water penetrates the equipment's interior.
- Do not clean the lawn mower with running water, particularly with high-pressure water.
- Keep the handles dry, clean and free of oil and grease.
- At the end of the season, perform a general inspection of the lawn mower and remove any grass, dirt or other debris that may have accumulated.
- At the start of each season, check the condition of the mower blade. If repairs are necessary, please call the customer service center for assistance at on: 1646687880

Servicing

- Ensure that all mounting components (e.g. screws, bolts, nuts etc.) are always tightened so that the equipment can be safely operated at all times.
- Frequently inspect the grass bag assembly for signs of wear and replace immediately with a genuine Hyundai part if damage is found.
- Replace excessively worn or damaged parts immediately.
- To maximise your mower's longevity, all screwed parts, including the wheels and axles, should be cleaned and lubricated.
- There are no parts inside the equipment which require additional maintenance or lubrication.

Replacing the mower blade

Note: The mower blade is sharp and can cause severe personal injury if handled incorrectly. Wrap the blade or wear protective gloves and use extra caution when servicing.

- The cutting components are subjected to more wear and tear than any other components on the unit. Therefore, routinely check the condition of the blade and make sure that it is tightly fastened. If the blade is completely worn, it must be immediately replaced or re-sharpened.
- An excessively vibrating mower means that the blade is not properly balanced or has become deformed from striking an object. In this case, the blade must be

Cleaning and maintenance

- repaired or replaced.
- For safety reasons, we recommend having the blade replaced or re-sharpened by an authorised service centre.

Ordering replacement parts

When servicing the mower, use only genuine replacement parts that are available from the manufacturer. In order to obtain replacement parts, call our toll-free customer service helpline at 1646687880. The use of parts that do not meet the original equipment specifications may lead to improper performance of the lawn mower, may compromise operator safety and will void the manufacturer's warranty.

Technical data

In the case of all other types of technical faults, please contact the Helpline.

Battery voltage	58V d.c.
Battery capacity	2.5Ah
No load speed	2800RPM
Cutting width	42cm
Cutting height	20mm-70mm
Grass bag capacity	45L

Noise data

Sound pressure level LPA	76.8dB(A) $K_{PA}=3dB(A)$
Guaranteed sound power level L_{WA}	94dB(A)



WARNING! The vibration emission value during actual use of the power tool can differ from the declared value, depending on the ways in which the tool is used. The following factors effect the vibration emission value:

1. How the tool is used.
2. If the tool is in good condition and well maintained.
3. If the correct accessory is being used and whether it is sharp.

Accessories

58V d.c battery x1
Battery charger x1
Grass bag x1
Grass bag handle x1
Safety key x1
Cable clip x1
Upper handle quick clips x2
Lower handle quick clips x2

We recommend that you purchase your accessories from the same store that sold you the lawn mower. Use good quality accessories marked with a well-known brand name. Choose the type according to the work you intend to undertake. Refer to the accessory packaging for further details. Ask in your local store for more advice.

Troubleshooting

Suspected malfunctions are often due to causes that the users can fix themselves. Therefore check the product using this section. In most cases the problem can be solved quickly.

Fault	Possible Cause	Remedy
Motor does not start	<ul style="list-style-type: none"> a) Capacitor defective b) Battery pack empty c) Cable defective d) Switch/plug block defective e) Motor terminals or capacitor disconnected f) Mower standing in high grass g) Mower housing is clogged h) Safety key is not inserted i) Battery is not correctly inserted 	<ul style="list-style-type: none"> a) Contact an authorized service center b) Charge battery pack c) Check the cable d) Contact an authorized service center e) Contact an authorized service center f) Start motor on shorter grass or previously mowed area; change cutting height if necessary g) Clean housing so that the blade can run freely h) Insert safety key (Fig. 13) i) Remove the battery and reinsert
Motor performance drops	<ul style="list-style-type: none"> a) Grass too tall or damp b) Mower housing is clogged c) Blades badly worn d) Battery performance decreasing 	<ul style="list-style-type: none"> a) Correct the cutting height, Clean housing, Replace blades, Check the battery performance and charge the battery if necessary
Unclean cuts	<ul style="list-style-type: none"> a) Blades worn b) Wrong cutting height 	<ul style="list-style-type: none"> a) Replace or re-sharpen the blade; contact an authorized service center, Correct the cutting height

Recycling and disposal



1. The product comes in a package that protects it against damage during shipping. Keep the package until you are sure that all parts have been delivered and the product is working properly. Recycle the package afterwards.



2. WEEE symbol. Waste electrical products should not be disposed of with household waste. Please recycle where facilities exist. Check with your local authority or local store for recycling advice.



Genpower contact details

1. Postal address;

Genpower Limited, Isaac Way, Pembroke Dock,
Pembrokeshire, SA72 4RW, UK.

2. Telephone contact number;
Office +44 (0)1646 687880

3. Email contact;
aftersales@genpower.co.uk

4. Web site;
www.hyundaipowerequipment.co.uk

Warranty

To register your machine for the manufacturer's warranty, please visit
<https://www.hyundaipowerequipment.co.uk/warranty>

DECLARATIONS OF CONFORMITY

1. Genpower Ltd confirms that this Hyundai product conform to the following CE Directives;

- 1.1. 2006/42/EC (Machinery Directive)
- 1.2. 2014/30/EU(EMC)
- 1.3. 2011/65/EU(RoHS)
- 1.4. 2000/14/EC, Amended by 2005/88/EC (as amended)

EC DECLARATION OF CONFORMITY

The undersigned, as authorised by: **Genpower Ltd**
Declares that the following equipment manufactured under licence by Hyundai Korea
Conforms to the Directive

2000/14/EC, Amended by 2005/88/EC (as amended)

Of the European Parliament and of the council on the approximation of the laws of the Member States relating to the noise emission in the environment by equipment for use outdoors.

Equipment Category: **Cordless Lawnmowers**
Product Name/Model: **Hyundai HYM60Li420 (YT5149-04)**
Type/Serial No: **Battery Powered Lawnmowers**
Net installed power: **0.8KW**
The technical documentation is kept by: **Roland Llewelin, Genpower Ltd,
Issac Way, Pembroke
Dock, Pembrokeshire,
SA72 4RW.**

The conformity assessment procedure followed was in accordance with annex V of the Directive.

Notified Body: **TÜV Rheinland LGAProducts
GmbH.Tillystraße 2-90431
Nürnberg,Germany**

Guaranteed Sound Power Level: **94 dB(A)**

A copy of this certificate has been submitted to the European Commission and to EU Member State United Kingdom.

Place of Declaration: **Pembroke Dock, SA72 4RW**

Date: **11/1/2018**
Signed by: **Roland Llewelin**
Position in Company: **Managing Director**
Named and address of manufacture or Authorised representative:
**Genpower Ltd
Issac Way, Pembroke
Dock, Pembrokeshire,
SA72 4RW.**



HYUNDAI

POWER PRODUCTS

For Inquiries, Please Contact:

GENPOWER LTD

Isaac Way, London Road

Pembroke Dock, UNITED KINGDOM, SA72 4RW

T: +44 (0) 1646 687 880 F: +44 (0) 1646 686 198

E: info@hyundaipowerequipment.co.uk

www.hyundaipowerequipment.co.uk

Imported/Distributed by GENPOWER LTD

Licensed by Hyundai Corporation, Korea