

Wall Mounted WC fixings

INFORMATION GUIDE

Contents

Safety Information **Page - 2**

Installation **Page - 2**

Safety Equipment **Page - 5**

Aftercare **Page - 6**

Your Guarantee **Page - 6**

Recycling and Disposal **Page - 6**

Contact Us **Page - 6**

Safety Information

Please read carefully...

- ✓ Check that all required components have been provided.
- ✗ Do not attempt to install a toilet if you notice any cracks or damage to the glaze. Contact the supplier.
- ✓ We recommend that installation and fixing is performed by a qualified installer.
- ✓ Be careful when handling the toilet as it can contain sharp edges were appropriate PPE.

Installation

Parts needed:

Wall Mounted Toilet Fixings

Tools required for installing:

1. Allen key (provided)
2. Tightening Tool

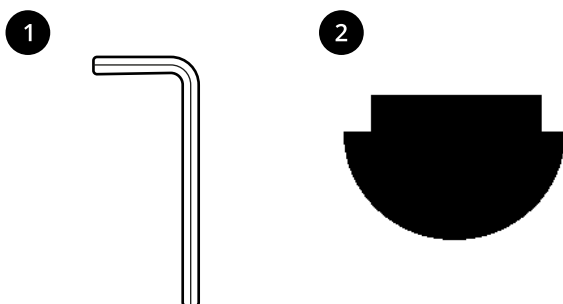

Check that all components are included and are undamaged.

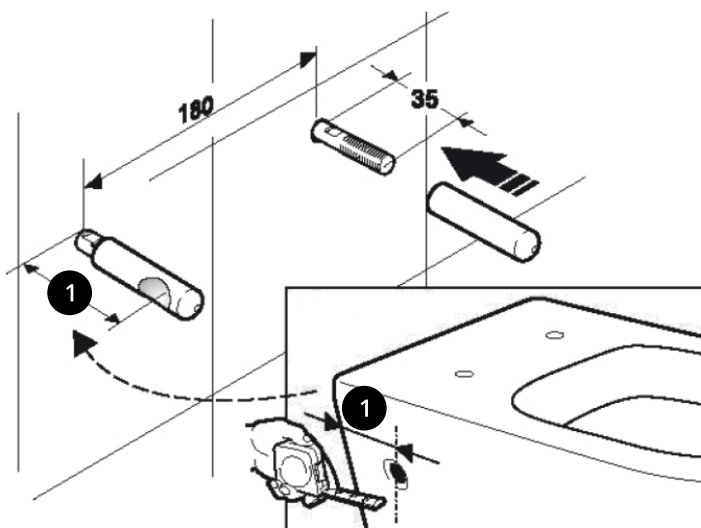
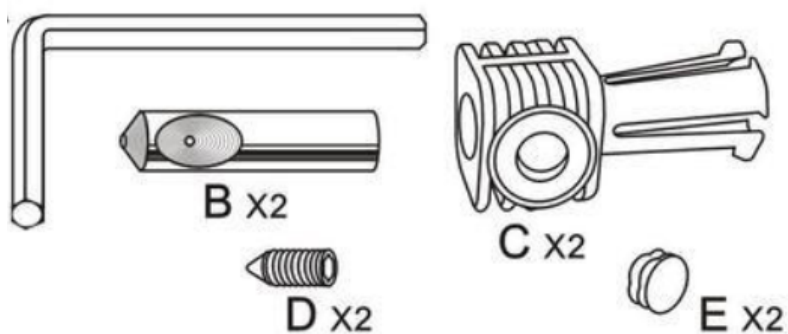

Screw the chrome locking bolts onto the threaded bars protruding from the wall, please make sure that the concave groove is facing outwards and that it will line up with the hole in your WC.

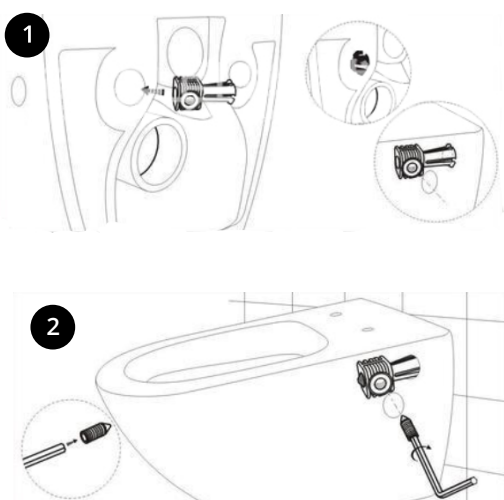

Insert the fixings into the fixing holes in the pan (this may have to be done from underneath the pan in some instances) (1).

Insert the grub screw loosely into the side of the bracket (2)
Offer the WC pan up to the wall connection (3).

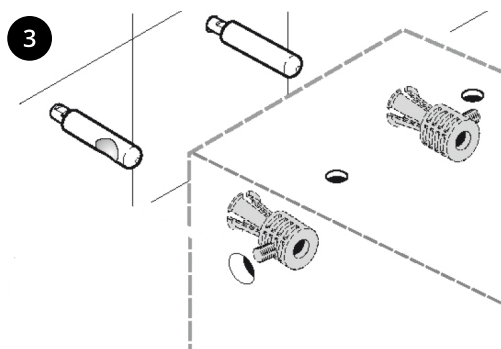

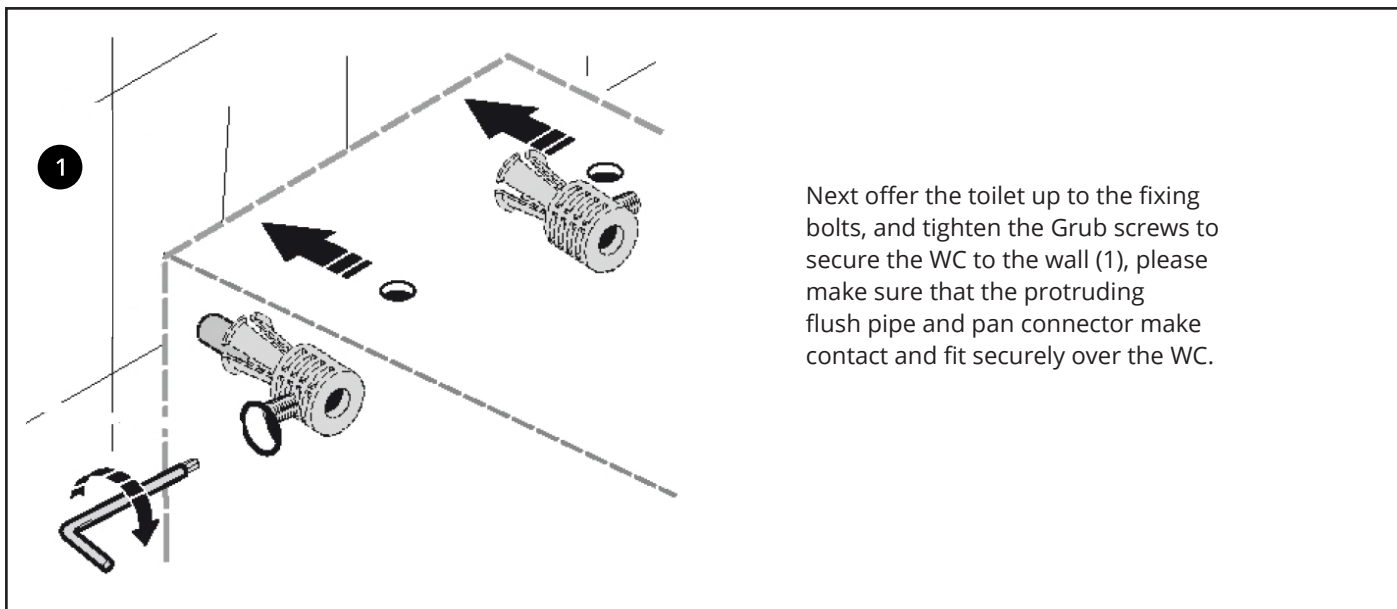

Safety Equipment

Please read carefully...

Please ensure that you wear appropriate Safety equipment while installing a toilet. Toilets can be heavy and have sharp edges in areas where you might try to pick them up .

We advise that a second person is present to assist with lifting the toilet when required.

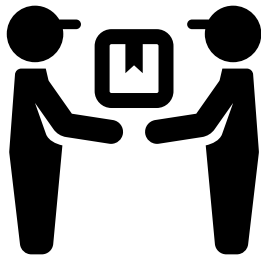

Aftercare

Periodically check the fixings for signs of wear and tear e.g. If the toilet starts to pull away from the wallframe. If you notice any signs of wearing, please contact the manufacturer.

Your Guarantee

- *This product is covered by a 10 year guarantee.*
- *The guarantee starts from the date of purchase.*
- *The guarantee covers you against issues caused as a result of manufacturing related issues, it does not apply to issues that are found to be a result of poor installation.*
- *Labour costs for installation of the product are not covered under this warranty.*

Recycling and Disposal

Please recycle / dispose of this product in accordance with your local council / government guidelines.

Contact Us

LDG

Unit 1 & 2 Dawsons Ct

Burnley

BB11 5UB