

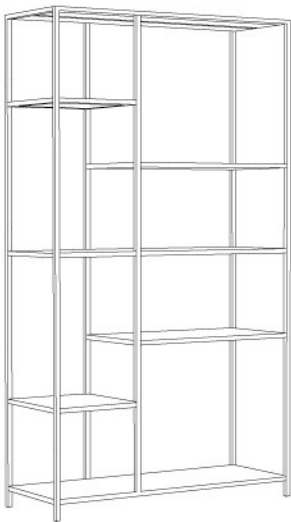



frankystar

Padma

frankystar



**SPECIFICHE TECNICHE / TECHNICAL SPECIFICATIONS / PÁGINA
TÉCNICA / PAGE TECHNIQUE**







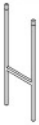

U K	Img	L	W	H
		80	30	164
I T	Img	L	P	A
		80	30	164
F R	Img	L	P	H
		80	30	164
E S	Img	A	P	A
		80	30	164

frankystar

Pag. Tec.
Page Tech.

Spec. Tec.
Tech. Specs.

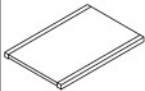
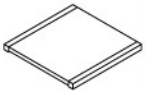
LISTA PARTI/PARTS LIST/ LISTA DE PIEZAS/ LISTE DES PIÈCES



1	x1	2	x1	3	x1	4	x1
							
5	x2	6	x2	7	x2	8	x2
							
9	x2	10	x2	A	x32	B	x10
							

frankystar

Pag. Tec.
Page Tech.

Spec. Tec.
Tech. Specs.

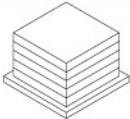
LISTA PARTI/PARTS LIST/ LISTA DE PIEZAS/ LISTE DES PIÈCES

D	x4	E	x4	F	x1
					

frankystar

MONTAGGIO / ASSEMBLY / MONTAJE / MONTAGE

Connect the pipe fittings as shown in the figure

Collegare i raccordi dei tubi come indicato nella figura

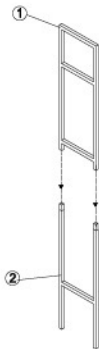

Connecter les raccords de tuyauterie comme indiqué sur la figure

Conecte los accesorios de tubería como se muestra en la figura

frankystar

Montaje
Montage

Montaggio
Assembly

7

MONTAGGIO / ASSEMBLY / MONTAJE / MONTAGE

Fix No. 7 to the pipe fittings connecting No.5 and No.6 with screw B

Fissare il n. 7 ai raccordi dei tubi che collegano il n. 5 e il n. 6 con la vite B

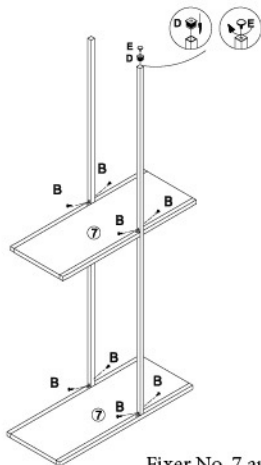

Fije el nº 7 a los racores que unen el nº 5 y el nº 6 con el tornillo B

Fixer No. 7 aux raccords de tuyauterie reliant No. 5 et No. 6 avec la vis B

frankystar

Montaje
Montage

Montaggio
Assembly

MONTAGGIO / ASSEMBLY / MONTAJE / MONTAGE

As shown in the figure, fix screws A to secure No.8, No.9 and No.10

Come mostrato in figura, fissare le viti A per bloccare i numeri 8, 9 e 10.

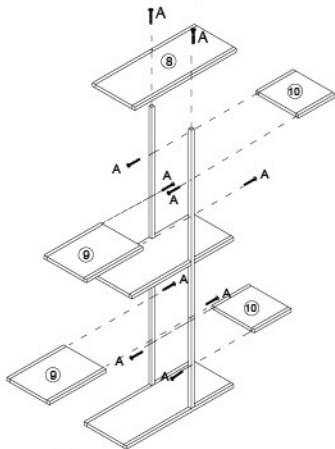

Comme indiqué sur la figure, fixez les vis A pour fixer les n° 8, 9 et 10.

Como se muestra en la figura, fije los tornillos A para sujetar los números 8, 9 y 10.

frankystar

Montaje
Montage

Montaggio
Assembly

MONTAGGIO / ASSEMBLY / MONTAJE / MONTAGE

Finally, use screws A to connect and secure the components

Infine, utilizzare le viti A per collegare e fissare i componenti.

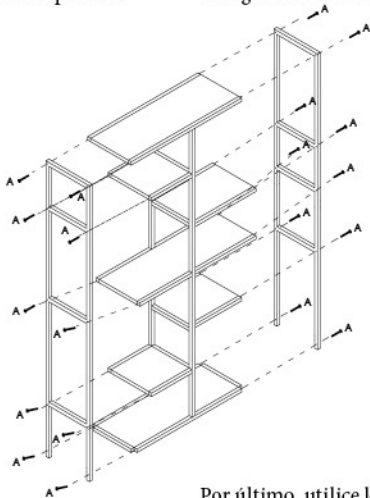

Enfin, utilisez les vis A pour connecter et fixer les composants

Por último, utilice los tornillos A para conectar y fijar los componentes

frankystar

Montaje
Montage

Montaggio
Assembly

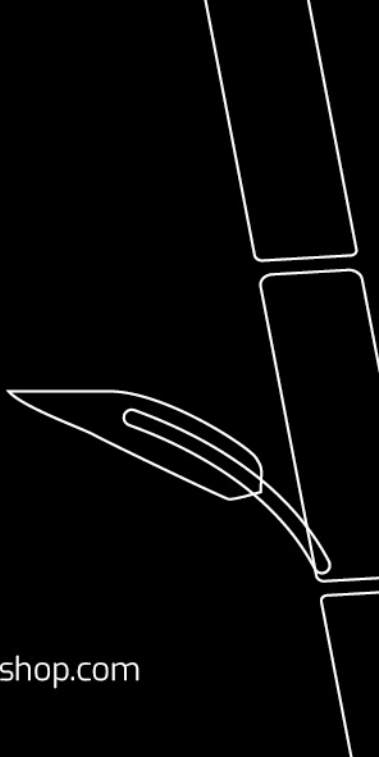

franchinishop.com