

CEGAR

ROMAN BENCH

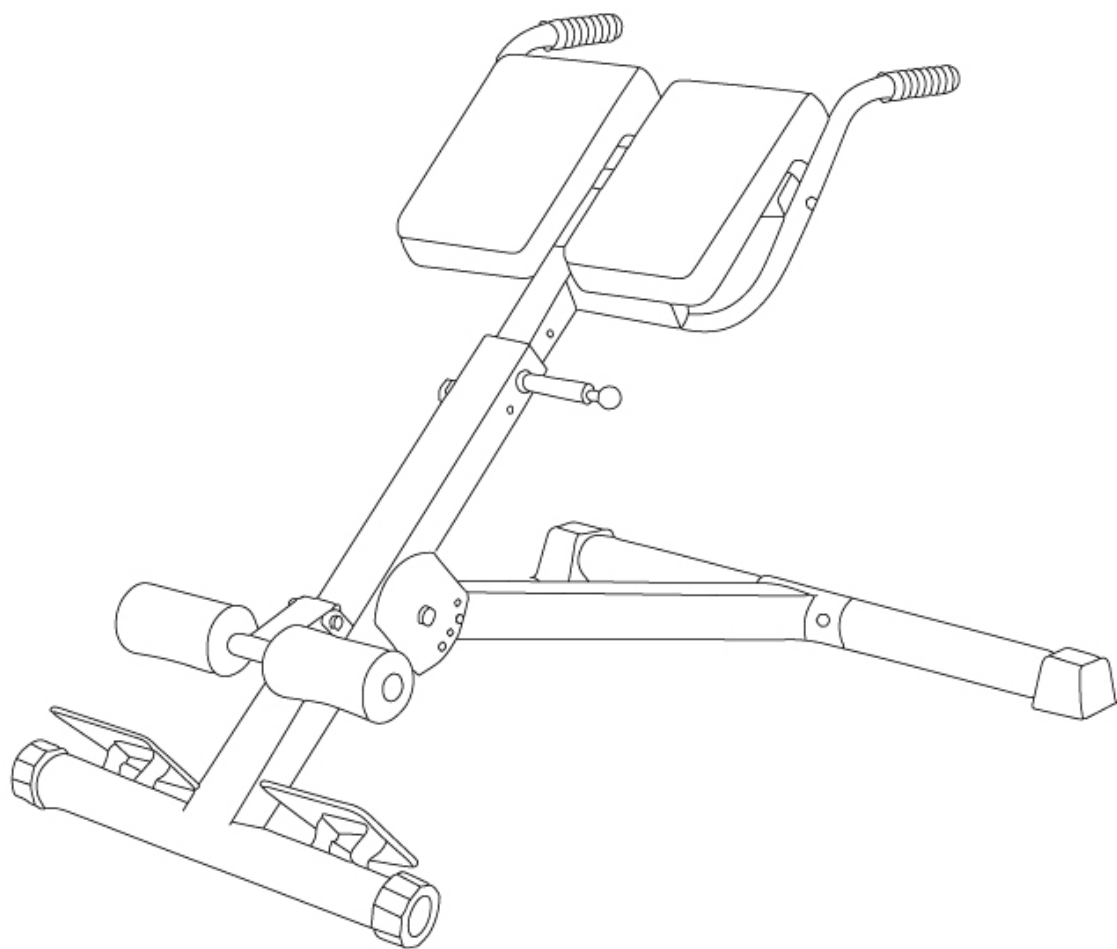

IT

FR

UK

ES



BOUDECH







I N D E X

- p 4. Tech.Specs./Spec. Tec. - Multilanguage
- p 5. Parts List/Lista Parti - Multilanguage
- p 6-7. Assembly/Montaggio - Multilanguage

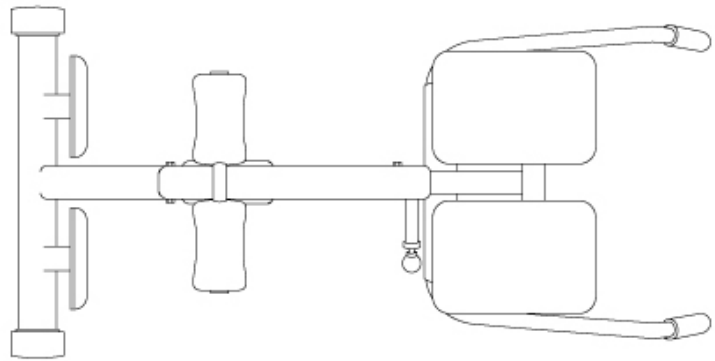
TECHNICAL SPECIFICATIONS / SPECIFICHE TECNICHE

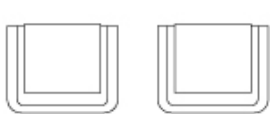
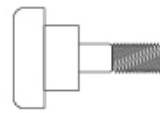
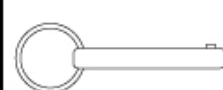
IT	<ul style="list-style-type: none"> • 7 livelli di altezza • 4 Livelli di inclinazione • Sistema di bloccaggio rapido • Telaio Richiudibile salvaspazio 	Livelli di altezza	Materiale Del Telaio:	Materiale Dell'Imbottitura
		(96cm, 101cm, 106cm, 112cm, 117cm 122cm e 128cm)	Acciaio Polverizzato	Spuma Espansa ad alta densità
UK	<ul style="list-style-type: none"> • 7 height levels • 4 Inclination levels • Rapid locking system • Space-saving folding frame 	Height levels	Frame material:	Padding Material
		(96cm, 101cm, 106cm, 112cm, 117cm 122cm e 128cm)	Powdered steel	High density foam
ES	<ul style="list-style-type: none"> • 7 niveles de altura • 4 Inclinación niveles • Sistema de cierre rápido • Marco plegable que ahorra espacio 	Niveles de altura	Material del marco:	Material de acolchado
		(96cm, 101cm, 106cm, 112cm, 117cm 122cm e 128cm)	Acero con recubrimiento de polvo	Espuma de alta densidad
FR	<ul style="list-style-type: none"> • 7 niveaux de hauteur • 4 niveaux d'inclinaison • Système de verrouillage rapide • Cadre pliant peu encombrant 	Niveaux de hauteur	Matériau du cadre :	Matériau de rembourrage
		(96cm, 101cm, 106cm, 112cm, 117cm 122cm e 128cm)	Acier à revêtement en poudre	Mousse haute densité

PARTS DIAGRAM/ DIAGRAMMA DELLE PARTI

A						
B						
C						
D						
E						
			2 - M7 X 5,5	2 - M8 X 7,7		
F						

PARTS DESCRIPTION/ DESCRIZIONE PARTI

	A	B	C	D	E	F
IT	Telaio	Piede Posteriore	Connettore	Gommini Antiscivolo	Manopola Pin Viti	Chiave
UK	Frame	Back Frame	Connector	Rubbers	Knob Pin Screws	Key
ES	Marco	Marco trasero	Conector	Almohadillas de goma	Pomo Pin Tornillos	Clave
FR	Cadre	Cadre arriere	Connecteur	Coussinets antidérapants	Mitten Pin Vis	Clé

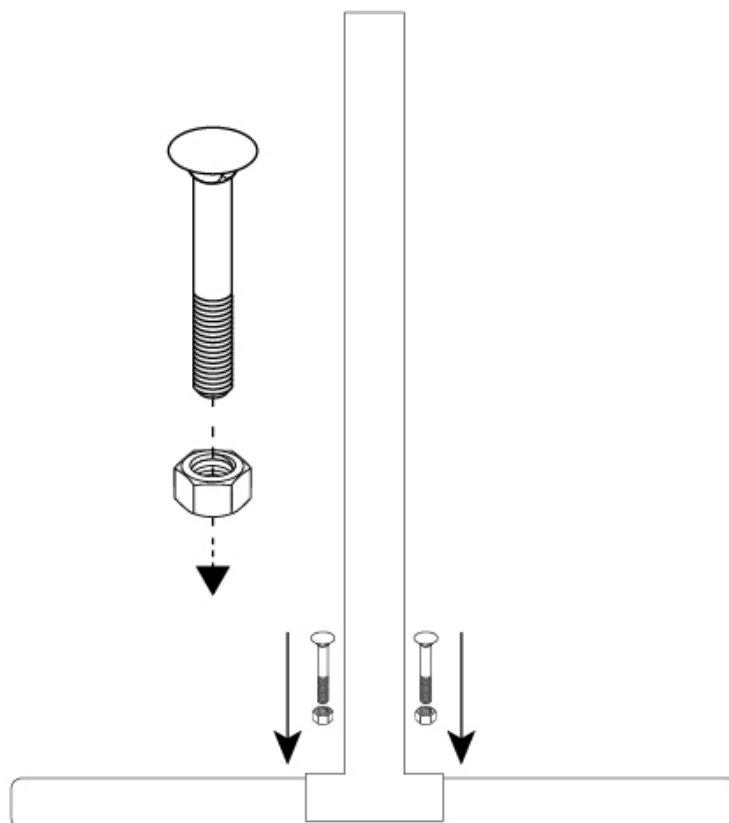

STEP 1

IT

Collegare il piede posteriore (B) al connettore centrale (C) utilizzando i due set di dado e vite M7x55

UK

Connect the rear foot (B) to the central connector (C) using the two sets of nut and screw M7x55

ES

Conecte el pie trasero (B) al conector central (C) utilizando los dos juegos de tuerca y tornillo M7x55

FR

Connectez le pied arrière (B) au connecteur central (C) en utilisant les deux jeux d'écrous et de vis M7x55.

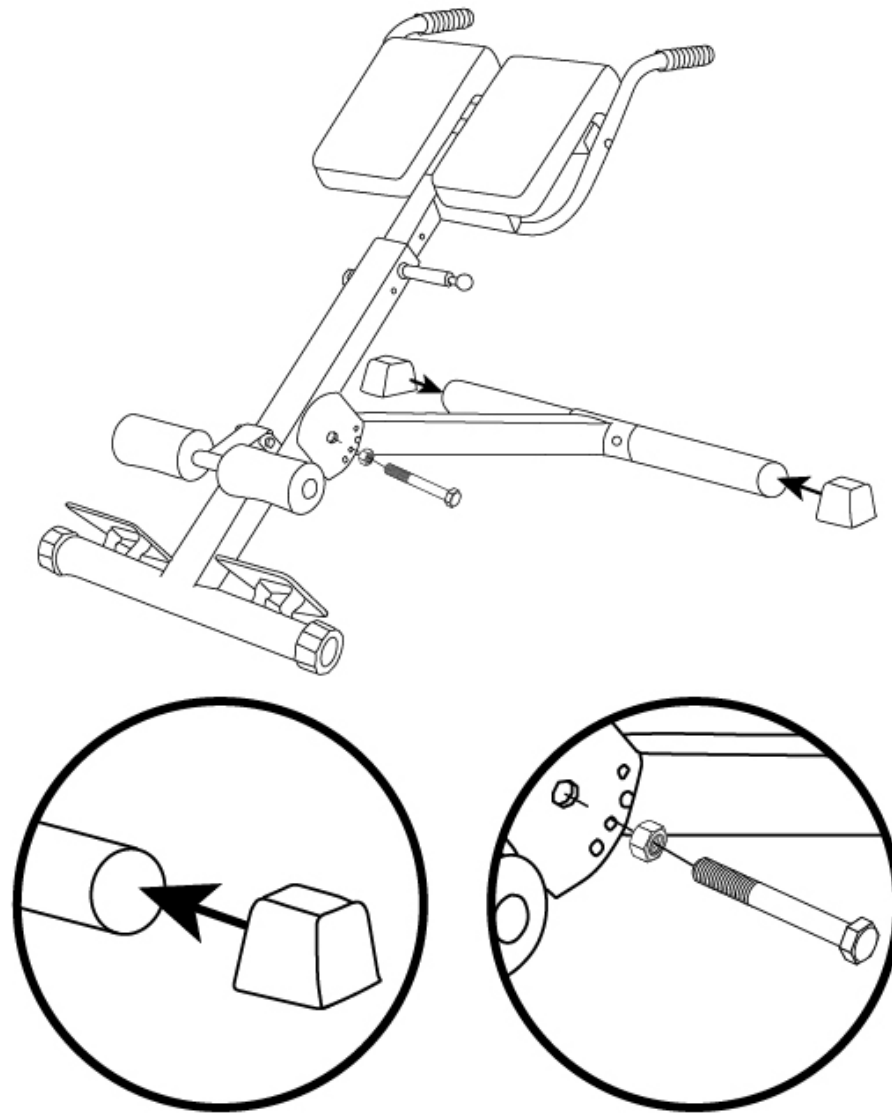

STEP 2

IT	Collegare il pre-assemblato precedente al telaio (A) utilizzando il set dado e vite M8x77 ed il pin. Montare i gommini antiscivolo ed inserire la manopola di regolazione dell'altezza, prima di iniziare l'allenamento addominale.
UK	Connect the previous pre-assembled unit to the frame (A) using the M8x77 screw and nut set and the pin. Fit the non-slip rubber pads and insert the height adjustment knob before starting abdominal training.
ES	Fije la unidad premontada anterior al bastidor (A) utilizando el juego de tuercas y tornillos M8x77 y el pasador. Monte las almohadillas de goma antideslizantes e inserte el mando de ajuste de la altura, antes de comenzar el entrenamiento abdominal.
FR	Fixez l'unité prémontée précédente au cadre (A) à l'aide du jeu d'écrous et de vis M8x77 et de la goupille. Montez les patins en caoutchouc antidérapants et insérez le bouton de réglage de la hauteur, avant de commencer la séance d'abdominaux.

DISCOVER ALL OUR PRODUCTS ON
FRANCHINISHOP.COM

BOUDECH

EMPOWERING EQUIPMENTS



B

DISCOVER ALL OUR PRODUCTS ON
FRANCHINISHOP.COM