



# **CLEVER CLICK** Luxury Vinyl Flooring

Technical Information

Revolutionary, quick and easy flooring with the natural beauty of wood and stone

**Ticks  
all  
the  
boxes** 

  
**Guardian**<sup>TM</sup>  
Building Products

## General Guidelines

Welcome to your brand new Clever Click design floor.

Clever Click is designed to offer all the stunning detail and outstanding beauty of natural materials, but with quick and easy installation.



### Storage and transportation

Cartons should be stored and transported on a flat surface in neat stacks. Always store the cartons flat and never put them upright. Do not store the cartons in very cold (less than 2°C/35°F) or very warm (more than 40°C/104°F) or humid places.

### Prior to fitting

#### General conditions

The installation of Clever Click is straight forward and follows the same guidelines that apply to all quality resilient tile floors. Good preparation is essential for a trouble-free installation. Clever Click can be laid on concrete, timber, stone and many other subfloors, which have been suitably prepared.

Site conditions must comply with the relevant national regulations. Clever Click is not suitable for external installation or unheated locations but it can be used with under-floor heating providing it is switched off for 24 hours before and after laying (the maximum permitted surface temperature is 28°C/81°F).

Following installation, Clever Click should be protected from heavy traffic for 24 hours and must not be washed for 24 hours. Always follow other manufacturers' recommendations when using their proprietary materials for sub-floor preparation.

#### Visual inspection

Please inspect product prior to installation. Check that the colours correspond to those ordered, the quantities are correct and there is no visible damage to the boxes. Check the vinyl planks or tiles during installation for any visible defects. Check that the tongue and groove of the click profile is free from dirt and undamaged. Do not install any planks or tiles that display any imperfections.

#### Suitability

Clever Click can be laid on concrete, cementitious screed, anhydrite (calcium sulphate), timber and ceramic tiles, which have been suitably prepared.

Clever Click can be used with traditional water based underfloor heating and cooling systems. If using electric wire systems please contact the manufacturer for correct installation methods.

For areas that are subject to extreme temperatures or to excessive direct heat source as fully glazed sun facing windows or conservatories we recommend that the Clever Click is installed with XtraFloor Flex Pro.

#### Moisture content of the subfloor

- ◆ Unheated cementitious screeds less than 2.0CM%.
- ◆ Underfloor heated cementitious screeds less than 1.8CM%.
- ◆ Unheated anhydrite (calcium sulphate) screeds less than 0.5CM%.
- ◆ Underfloor heated anhydrite (calcium sulphate) less than 0.3CM%.

Direct-to-earth concrete and stone subfloors must have an effective damp proof membrane (DPM). Follow manufacturer's detailed instructions for the installation of a surface DPM and the use of levelling compound.

### Temperature conditions before, during and after installation

Clever Click is best installed with a room temperature of between 18°C/64°F and 27°C/81°F and a floor temperature of above 15°C/59°F. Installations in areas colder than recommended will influence the convenience friendly installation properties of Clever Click.

The planks or tiles could be less easy to handle and less flexible, whilst cutting could be heavier with small pieces difficult to cut out. The lower the temperature, the more difficult to handle.

For installation in areas warmer than recommended, we advise consultation with your local installer on how to create the appropriate installation conditions.

A constant temperature, fluctuating no more than 5°C per day and not below the required 18°C room temperature and 15°C floor temperature, should be maintained 24 hours before, during and 72 hours after installation.

### Acclimatisation

Clever Click must acclimatise in the room of installation, or an equivalent area for at least 24 hours prior to installation, or until such time as the product has achieved an ambient temperature. Again, this is a minimum temperature of 18°C/64°F and a maximum of 27°C/81°F.

- ◆ Unpack the Clever Click and check all planks or tiles in daylight for possible defects or discrepancies in colour.
- ◆ Stack the plank or tiles in straight piles away from heating, cooling or windows with direct intense sunlight. This is to achieve a gradual acclimatisation.

### Underfloor heating

Clever Click can be used with traditional water based underfloor heating systems, provided there is a constant room temperature of 18°C/64°F for the acclimatisation period, installation and 72 hours after installation.

The underfloor heating must be gradually increased by increments of 5°C/41°F until it reaches the standard operating temperature conditions, with a maximum temperature of 27°C/81°F.

For suitability of the system please check the manufacturer's instructions.

### Contact with water

Prevent the floor from coming into contact with a large amount of water, or from being submerged, as the click connection is not fully waterproof.

## General Guidelines



### RECOMMENDED TOOLS

- ◆ Broom and / or vacuum cleaner
- ◆ Tape measure
- ◆ Pencil
- ◆ Set square and ruler
- ◆ Utility knife
- ◆ Rubber mallet
- ◆ Tapping block

### Fitting instructions

#### Installation from one batch

For best results, mix at least two packs when fitting to avoid repetitions in the pattern. We recommend that you always use materials from a single production batch for each installation, as a match between batches cannot be guaranteed.

#### Easy to cut

Clever Click planks or tiles are easily cut using a straight blade in a utility knife. Cut the printside of the plank or tile several times and snap along the line.

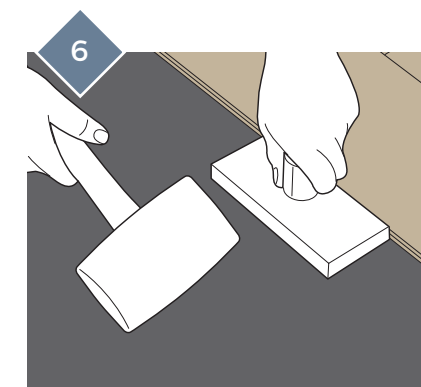
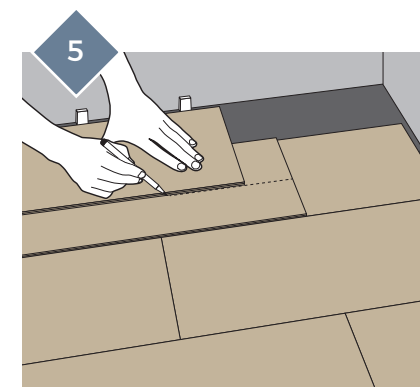
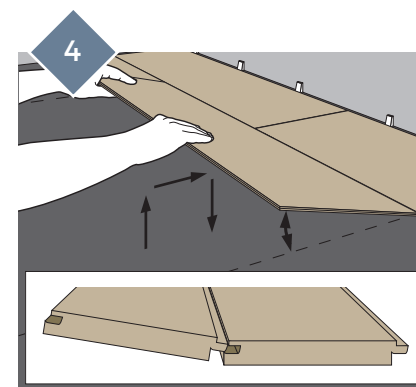
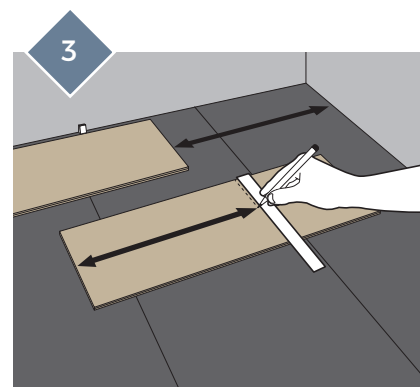
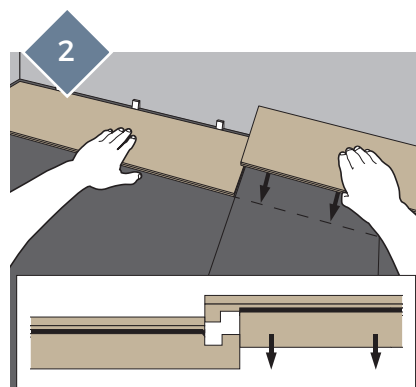
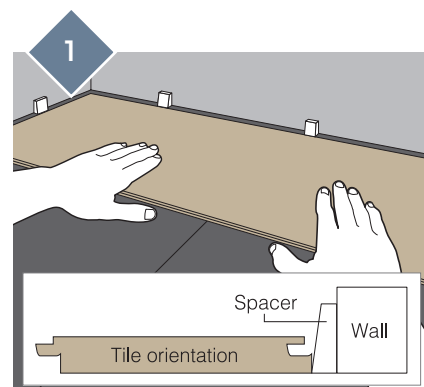

### Step-by-step fitting instructions

The surface beneath the floor must be sufficiently prepared in advance to guarantee successful fitting of the floor covering. In particular, it must be clean, dry, smooth, firm, level, free from defects and not contaminated with grease, oil or chemicals.

Clever Click is a "floating" floor. Never glue or fix the panels to the surface below. The flooring can be installed wall-to-wall, however in large areas (greater than 50m<sup>2</sup>) or where the floor may be exposed to unusually wide temperature ranges (such as where under floor heating is used, in a conservatory or areas adjacent to a south facing window), then it is advisable to use a 5mm space around the edge, as appropriate.

For surfaces larger than 50m<sup>2</sup>, we advise that an expansion joint of 5mm is created around the perimeter of the room. In addition, should a single wall or run be longer than 10 linear metres, then a 5mm expansion joint should be allowed around the perimeter. If you are uncertain of the requirements, please contact your retailer who can confirm the exact requirements.

The Clever Click system panels can be joined in two different ways: either tongue-in-groove or groove-in-tongue. The simplest procedure, however, is groove-in-tongue. The advantage of the Clever Click system is that it allows you to choose your own starting position.

Moreover, you may work either from left to right or from right to left, whichever is best for you. Depending on the direction in which you work, you are advised to begin from either a corner or a door. It is advisable to begin with the groove side of the plank towards the wall and work from left to right.

- 1) Measure the room carefully to determine the central axis, from which the first row to be laid is outlined.
- 2) Check whether the first row of panels needs to be narrowed. If not, the lower groove lip of the first row of panels need to be removed. Use a utility knife to neatly cut off the lower groove lip.
- 3) Begin by laying the first row in the corner of the room on your left hand side as you are looking at the wall. Always work from left to right and with the tongue towards yourself. (Figure 1).

- 4) Lay the first row in a straight line and click the head ends together. Put the short side of the profile into head end of the previous panel and press the panel downwards. It is recommended to use a rubber mallet for connecting the head ends so that the joint fits securely. Continue laying the first row in the same way until you get to the last piece. (Figure 2).

- 5) For the last piece, measure the last plank to ensure a tight fit to the wall. Then cut away the marked piece and fit the end panel in the same way as the previous panels. When cutting the panel with a utility knife, make sure that you cut through the wear layer before breaking the panel. (Figure 3).
- 6) For an attractive and natural appearance, we advise you to use the piece left over from row 1 as the first piece in the next row, as long as the remaining piece is at least 1/3 of the total plank length. Repeat for all subsequent rows.

- 7) Fit the second row as you did for the first: start on the left side and slide the groove of the panel under an angle of about 25° over the tongue of the previous row and click the groove into the tongue by laying down the panel while pushing it firmly against the first row. (Figure 4).

- 8) Then fit the second panel by sliding the groove under at an angle of 25° into the tongue of the previous row. Position the corner of the head end against the previous panel and then drop the short side of the profile into the head end of the previous panel and push downwards. Use a rubber mallet for connecting the head ends so that the joint fits securely. Repeat until you reach the end of the row.

- 9) To ensure a firm Click installation, it is recommended that the planks are tapped together along the long edge with a tapping block and a rubber mallet. This will ensure that the Click mechanism is firmly locked during installation, providing a secure joint and avoiding any movement after the installation has been completed. (Figure 5)

- 10) To fit the last row of panels you will usually need to narrow them. Do this as follows: lay a panel on top of the previous row with the groove towards the wall, lay another panel upside down up to the edge of the wall and mark the panel underneath. Cut the panel to size and fit the last row. (Figure 6)

- 11) Door posts and heating pipes also need to be individually fitted. First cut the panel to the right length. Then place the panel next to the object and draw the correct fitting. Next, cut the panel to size. Doorposts can also be sawn to size if necessary to lay the floor beneath them. For cutting around difficult areas such as door posts, heating pipes and other interior furniture; the use of a Jigsaw with the correct plastic cutting blades is suitable and will avoid unsightly cuts at the perimeter of the room.

### Congratulations!

You have just installed a Clever Click design floor. Your new floor has been produced in accordance with the highest standards and will give you years of pleasure in your home.

Although Clever Click design floors are one of the easiest floors to take care of, it is best to follow the recommendations, provided on page 6, for optimal protection of the factory finish and to keep your floor looking fresh.



## General Floor Maintenance

### Daily sweeping and dust mopping

- 1) Pick up litter and thoroughly sweep the floor area.
- 2) Pick up debris with dustpan and brush or vacuum.
- 3) Vacuum walk-off mats and crevices at entrance(s).

### Manual mopping – Ideal for small or congested areas.

Manual mopping is used for soil removal in small or congested areas (including within large floors) and some mark removal. Spray cleaning may be required for heavier surface marking. (Note: In conditions of heavy soiling, perform a pre-wash by preparing a solution of Xtrafloor Cleaner Maintainer diluted in accordance with the label and pre-wash heavily soiled areas).

- 1) Using a two-bucket mopping system, apply solution using well-wrung mop to remove soiling.
- 2) Mop using overlapping strokes.
- 3) Rinse the mop frequently and change the solution as necessary.
- 4) Allow entire floor area to dry thoroughly.
- 5) Remove "Caution" signs. Ensure all equipment is cleaned thoroughly after use and stored safely.



### Tips – Dealing with spills

- 1) Spills of water, grease, food, chemicals and other foreign matter may cause the floor to become slippery.
- 2) Wipe up spills immediately with an absorbent cloth and then wash thoroughly using Xtrafloor Spot Remover as directed on the label or properly diluted Xtrafloor Cleaner Maintainer until the spill area is completely clean.
- 3) Allow the floor to dry thoroughly.

### Notes

- 1) Clever Click products should not be buffed with any pad more abrasive than a red 3M pad (or equivalent).
- 2) Entrance mats, when properly serviced, can effectively remove any abrasive and foreign materials from foot traffic and cut down on tracked in water. Clever recommend a minimum of two full strides of entrance matting.

### Preventative maintenance

- 1) Place non-rubber doormats at entrances to stop large amounts of dirt from getting indoors.
- 2) Use felt under furniture and chair legs. Rolling office chairs should be fitted with non-rubber casters.
- 3) Clean the floor at least once a week with a vacuum cleaner or mop. You will need to do this more often if you use the floor intensively.
- 4) We advise that you only use recommended cleaning products, as aggressive cleaning products may damage the floor.
- 5) Stiletto heels can also damage the floor.
- 6) Avoid long-lasting exposure to direct sunlight. Use curtains or blinds at peak times to minimise the effect of direct sunlight. Most types of floor discolor under the influence of direct sunlight. To avoid colour discrepancies, you should move the floor coverings present with a certain degree of regularity.

### Starter Kit

The starter kit is designed to keep your luxury vinyl floor looking its best for years to come.

#### Contents

- ◆ 1L cleaner maintainer
- ◆ 500ml floor spill cleaner, flat cap loose trigger
- ◆ 1 pack of felt pads
- ◆ 1 non-abrasive sponge/scourer
- ◆ 6 blue cleaning cloths
- ◆ Promotional literature
- ◆ Instruction sheet



### Xtrafloor Cleaner Maintainer

Our concentrated cleaner has a fresh aroma for routine cleaning. Suitable for use with all cleaning methods including manual, spray buffing and scrubber-drying. Availability: 1 ltr / 2.5 ltr.

### Xtrafloor Spot Remover

A ready to use cleaner with a fresh aroma and formulated for removal of spills and other deposits. Availability: 500ml.

All floors should be swept and dust mopped daily, following which soiling and marking can be removed using the appropriate method described here.

Before commencing work, put out signs to warn people that cleaning is in progress.



## Technical Information

		Wood	Stone
<b>Product Information</b>			
Level of use	EN 685	23 - 33 - 42	23 - 33 - 42
Total thickness	EN 428	ca. 4.50mm	ca. 4.50mm
Wear layer	EN 429	ca. 0.55mm	ca. 0.55mm
Wear layer PUR treatment		Superguard®	Superguard®
Total weight kg/m <sup>2</sup>	EN 430	ca. 7.680	ca. 7.680
<b>Size and Packaging</b>			
Planks A	EN 427	191mm x 1316mm	324mm x 655mm
Box Planks A	7 pcs / box	1.76m <sup>2</sup> / box	1.49m <sup>2</sup> / box
<b>Test Results</b>			
Inflammability	EN 13501	Bfl-S1	Bfl-S1
Scratch resistance	EN 660-2	Class T	Class T
Squareness & straightness	EN 427	≤ 0.35mm (Planks A)	≤ 0.35mm (Tiles)
Slip resistance	EN 13893	DS	DS
Slip restraint	DIN 51130	R9 / R10	R9 / R10
Residual indentation	EN 433	≤ 0.10 mm	≤ 0.10 mm
Furniture leg resistance	EN 424	No cracks, no damage	No cracks, no damage
Curling	EN 434	≤ 2mm	≤ 2mm
Electrical resistance	EN 1081	≤ 10 <sup>9</sup> hm	≤ 10 <sup>9</sup> hm
Dimensional stability	EN 434	Norm: ≤ 0.25%, average result measured: ≤ 0.05%	Norm: ≤ 0.25%, average result measured: ≤ 0.05%
Heat insulation	EN 12524	0.25w/(m.K)	0.25w/(m.K)
Thermal resistance R	ISO 8302	0.0159m <sup>2</sup> .K/W	0.0159m <sup>2</sup> .K/W
Electrostatic performance	EN 1815	< 2kV	< 2kV
Fomaldehyde group	EN 717-1	E1	E1
Acoustic insulation	ISO 717-1	4dB	4dB
Castor chair resistance	EN 425	No damage to wearlayer, no de-lamination	No damage to wearlayer, no de-lamination
Stain resistance	EN 423	Very good	Very good
Light fastness	ISO 105-B02	≥ 6	≥ 6
Underfloor heating	EN 12524	Suitable, max 27°C	Suitable, max 27°C
Resistance to chemicals	EN 423	Very good	Very good
Warranty		20 year Residential 10 year Commercial	20 year Residential 10 year Commercial

The warranty covers manufacturing defects and premature wear in the event of normal use.

### Guardian Building Products

Tel: 01332 296844 Email: [info@guardianbp.co.uk](mailto:info@guardianbp.co.uk)

[www.guardianbp.co.uk](http://www.guardianbp.co.uk)

Whilst Guardian has made every attempt to ensure that this information is accurate and reliable at the time of its publication; we cannot accept responsibility for any errors, omissions, inaccuracies or any changes that have occurred since the date of publication or for the results obtained from the use of such information.

February 2017