



*Woodworking machinery at its best!*

**10" TABLE SAW  
OWNERS MANUAL**

**MODEL: W650**



**Charnwood, Cedar Court, Walker Road, Hilltop Industrial Estate,  
Bardon Hill, Leicestershire, LE67 1TU**

**Tel. 01530 516 926 Fax. 01530 516 929  
email: [sales@charnwood.net](mailto:sales@charnwood.net) website: [www.charnwood.net](http://www.charnwood.net)**

# GENERAL SAFETY RULES



**WARNING:** Do not attempt to operate the machine until you have read thoroughly and understood completely all instructions, rules, etc. contained in this manual.

Failure to comply may result in accidents involving fire, electric shock, or serious personal injury. Keep this owner's manual and review frequently for continuous safe operation.

1. Know your machine. For your own safety, read the owner's manual carefully. Learn its application and limitations, as well as specific potential hazards pertinent to this machine.
2. Make sure all tools are properly earthed.
3. Keep guards in place and in working order. If a guard must be removed for maintenance or cleaning, make sure it is properly replaced before using the machine again.
4. Remove adjusting keys and spanners. Form a habit of checking to see that the keys and adjusting spanners are removed from the machine before switched it on.
5. Keep your work area clean. Cluttered areas and workbenches increase the chance of an accident.'
6. Do not use in dangerous environments. Do not use power tools in damp or wet locations or expose them to rain. Keep work areas well illuminated.
7. Keep children away. All visitors should be kept a safe distance from the work area.
8. Make workshop childproof. Use padlocks, master switches and remove starter keys.
9. Do not force the machine. It will do the job better and be safer at the rate for which it is designed.
10. Use the right tools. Do not force the machine or attachments to do a job for which they are not designed. Contact the manufacturer or distributor if there is any question about the machine's suitability for a particular task.
11. Wear proper apparel. Avoid loose clothing, gloves, ties, rings, bracelets, and jewellery which could get caught in moving parts. Non-slip footwear is recommended. Wear protective hair covering to contain long hair.
12. Always use safety glasses. Normal spectacles only have impact resistant lenses. They are not safety glasses.
13. Do not over-reach. Keep proper footing and balance at all times.
14. Maintain the machine in good condition. Keep the machine clean for best and safest performance. Follow instructions for lubrication and changing accessories.
15. Disconnect the machine from power source before servicing and when changing the blade.
16. Never leave the machine running unattended. Turn the power off. Do not leave the machine until it comes to a complete stop.
17. Do not use any power tools while under the effects of drugs, alcohol or medication.

18. Always wear a face or dust mask if operation creates a lot of dust and/or chips. Always operate the tool in a well ventilated area and provide for proper dust removal. Use a suitable dust extractor.

## ADDITIONAL RULES FOR CIRCULAR SAWS

1. Ensure that the saw table is clear of off-cuts, tools or anything else that might foul the work-piece.
2. If your saw has a dust extractor hose connected to the crown guard, ensure that it is held clear of the table and will not foul the work-piece as it passes over the table.
3. When cutting large sheets of material or long boards use one or more roller stand(s) to support the work or have a competent helper to support it as it feeds off the rear of the table.
4. Never use the saw without the riving knife and check that it is in line with the blade before using the saw.
5. Always use a brush to clear the table of dust or debris. NEVER use your hands, especially when the machine is running.
6. ALWAYS USE A PUSH STICK WHEN IT IS NECESSARY TO PUSH ANY PIECE OF MATERIAL OF SUCH SIZE THAT IT WOULD BRING YOUR HANDS WITHIN 30cm OF THE BLADE.
7. Do not cut material that is badly warped or which has screws or nails in it
8. Be extra vigilant when cutting stock which has loose knots in it as these may fly out of the saw.
9. NEVER remove the table insert when the saw is running.
10. To avoid exposure to hazardous dust, do not use this saw without connecting it to a suitable dust extractor.
11. Always work with a sharp saw blade and feed the work at a rate suited to the thickness and hardness of the material.

Note: This table saw has been designed and built solely as a woodworking machine. Do not modify it in any way or use for anything other than its designated purpose. Neither the manufactures nor the supplies are liable for any damage or injury caused by incorrect assembly, operation or electrical connection of this machine.



Risk of Injury!  
Never reach into  
the running saw blade.



Eye  
Protection



Ear  
Protection

## Rating Description

Trade: Suitable for daily use by professional woodworkers.

Continuously rated, high power and a heavy duty construction. Typically used by several different operators in a small or medium sized business. Will be used up to the machines maximum limit with some long work periods. Expected maximum use of 1000 hours annually.

# Specification

Main table size	480(w) x 720(d) mm
Rear table size	480(w) x 280 (d) mm
Side Table size	270(w) x 720(d) mm
Table height	830mm
Motor (induction)	2200W (3hp), 240v single phase
Blade diameter and bore	254mm (10") x 30mm
Blade rotation speed (no load)	4000 rpm
Maximum depth of cut at 90	80mm
Maximum depth of cut at 45	56mm
Maximum ripping width using fence	610 mm (24")
Maximum cross cutting width	550mm/700mm (fence front/rear of table)
Dust extractor hose connection	100mm
Overall Dimensions (WxDxH)	1430mm x 1340mm x 1130mm
Weight Gross/Nett	150kg/125 kg

# Unpacking



This product is shipped in 3 Pieces:  
1 wooden crate and 2 cartons.

To open the wooden crate cut the strapping and lift the lid of the crate, from the base.

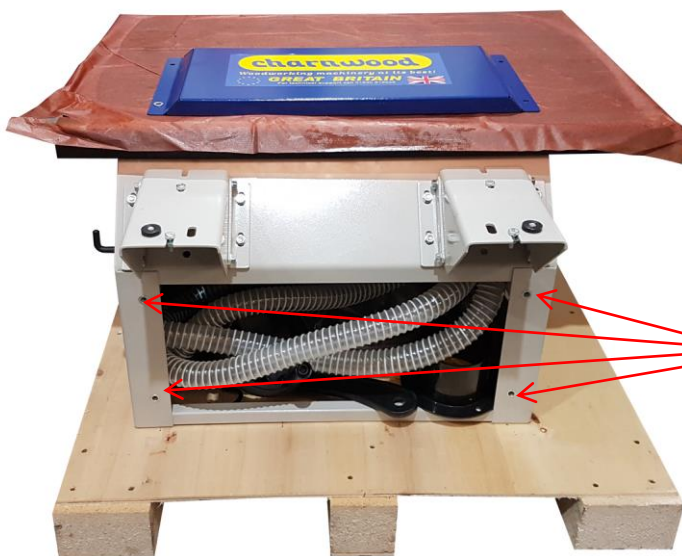

Remove the loose items surrounding the machine.

Use a cross head screw driver to remove 4 screws, then remove the blue access panel.

Remove the loose parts which are packed inside.

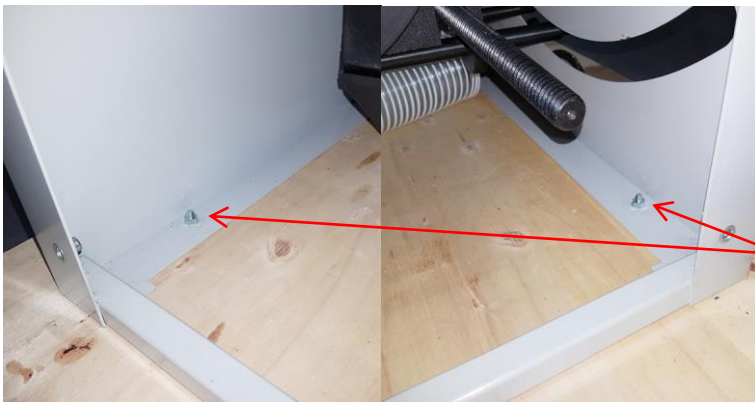

The body of the saw is fixed to the base with two bolts.

Use a 10mm spanner to undo the 2 securing nuts.



Unpack all of the remaining parts and check everything is present.

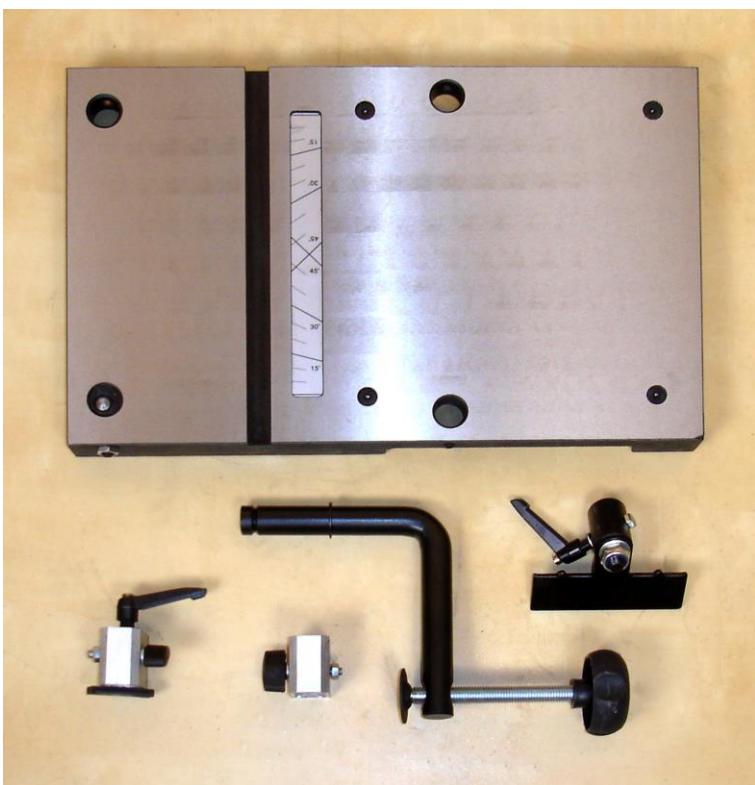

**Please Note:** Do not dispose of any packaging until the machine has been fully assembled and tested. In the unlikely event of a problem which requires the product to be returned, the packaging will need to be re-used.

## Assembly

Please Note: Assembly will require 2 people to lift the machine



The riving knife projects slightly above the surface of the table.

Using 2 suitable blocks of wood as support, invert the body of the saw so that the riving knife is not damaged.

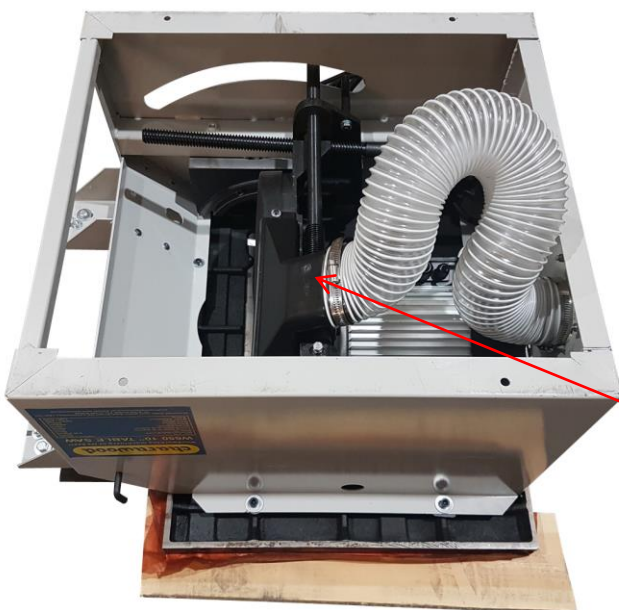

Attach the flexible hose.

The outlet to attach the hose to, is oval in shape.

Feed the hose clamp over the end of the hose.

Crush the end of the hose to the same approximate shape as the outlet.

Fit the end of the hose over the outlet and secure it with the hose clamp.



To assemble the base.

Locate:  
4 Panels  
4 Feet  
12 x M6 Bolt, Washer and nut



Screw the 4 feet into the threaded holes in the 2 side panels of the base.

Use a 17mm spanner to tighten them.

After full assembly of the machine, the feet can be adjusted to level up the machine.

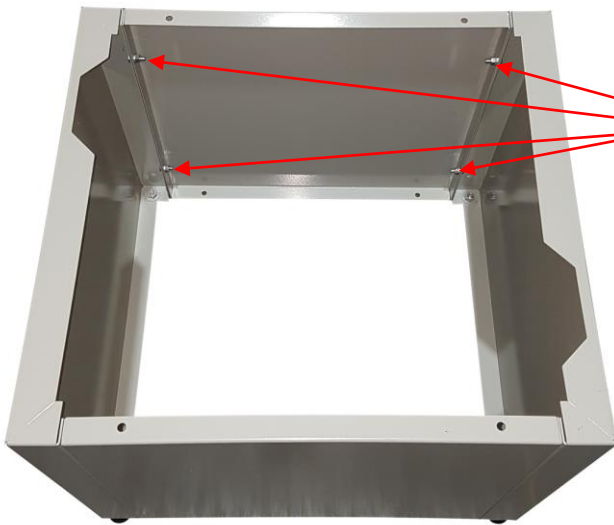

Use 8 of the bolts, washers and nuts to join the 4 panels together.

Fit all 8 bolts finger tight before tightening with a 10mm spanner.

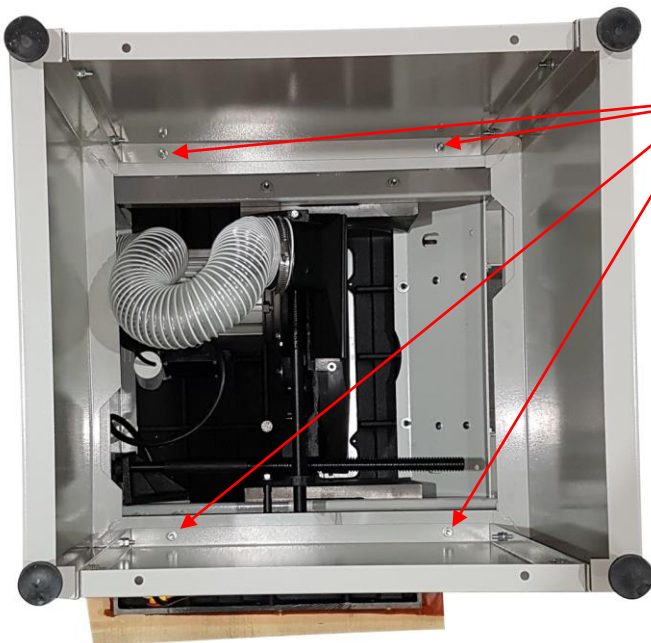

Sit the assembled base unit onto the upturned saw body.

Use the remaining 4 bolts, washers and nuts to attach the base to the saw body.

Once all of the nuts and bolts are tight. Turn the machine the correct way up and stand it on the feet.

Refit the Blue access panel.

Adjust the feet to level up if necessary.

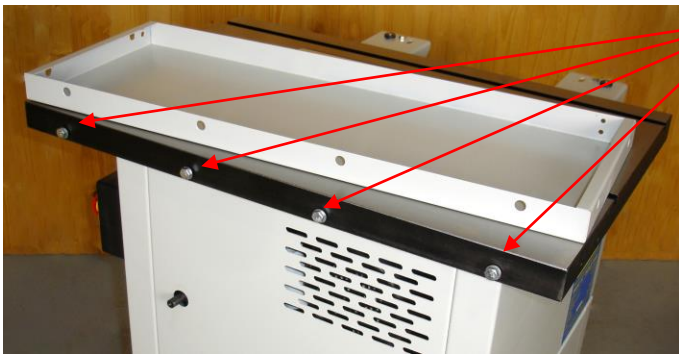

Unscrew the four bolts and use them, with their washers, to secure the side extension table to the main table by passing them through the holes in the extension table.



Using the long fence as a guide, level up the tables before tightening the bolts. Take the time to get this right as it is important to the accuracy of the saw.



Take the rear extension table and remove these two bolts. Use them to fix the rear extension to the back of the side extension.

Use four bolts and washers provided to fix the rear extension to the main cast iron table.

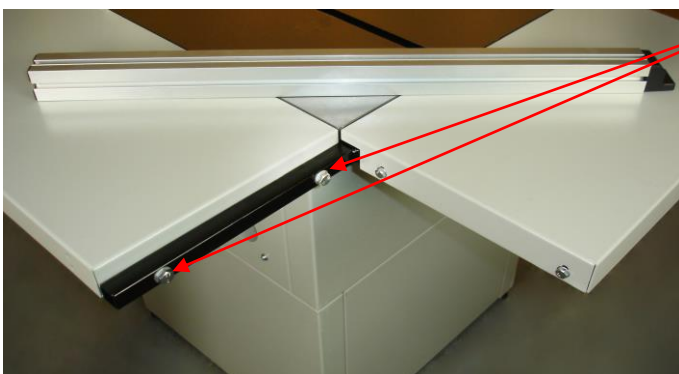

The final table assembly should look like this, with four bolts securing the rear extension table to the cast iron table and two bolts securing the rear extension table to the side extension table.

Use the long fence again to check the level of all 3 tables.



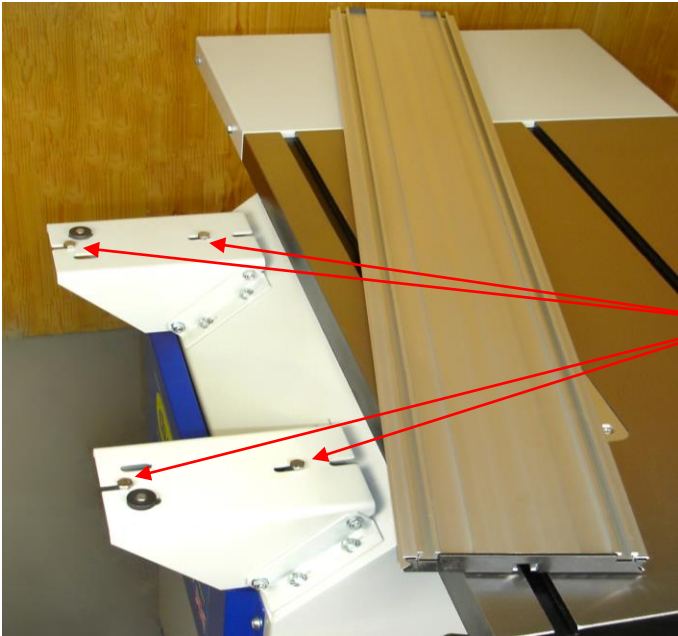

Loosen the four bolts indicated which will hold the guide rail for the sliding carriage.

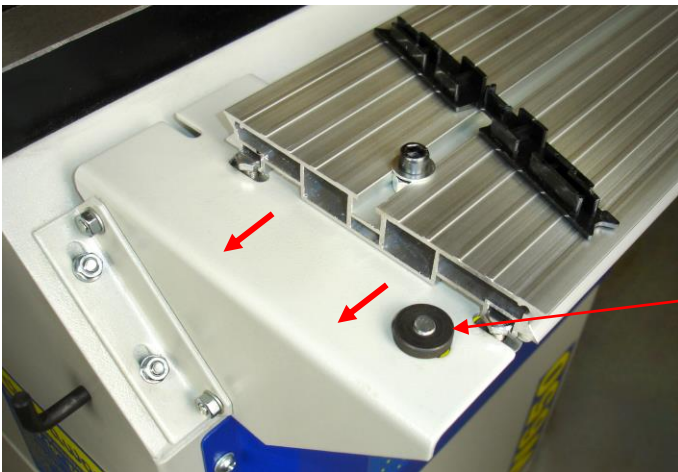

Prise out the plastic end cap from the guide rail extrusion. Feed the rail over the bolt heads, front bracket first, then on to the rear. Align the rear end of the rail with the rear edge of the cast table and re-tighten the four bolts. Refit the end cap.

The position of the rail will need to be adjusted according to the cut being made. Alignment of the rail with the table will be maintained by the guide discs which run along a channel in the underside of the rail. These discs are adjustable to enable parallel alignment with the table top/blade.



Before fitting the sliding carriage it should be noted that the two outboard bearing wheels are mounted on eccentric nuts.

Should it ever be necessary their position can be adjusted with a 14mm spanner to remove any sideways play in the table.

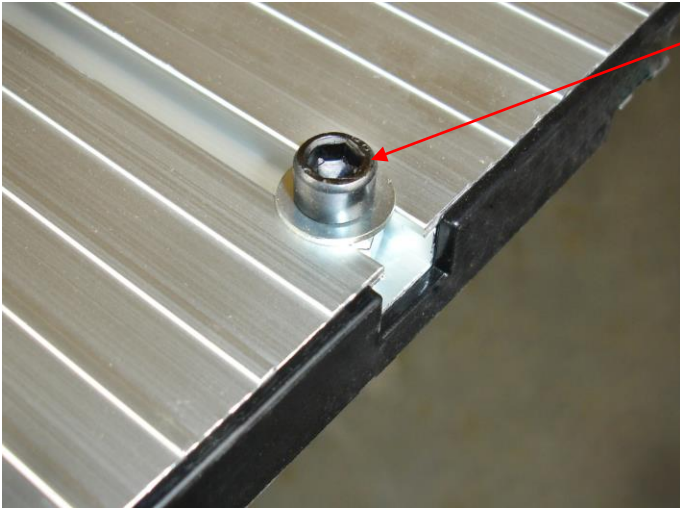

The guide rail is fitted with front and rear travel stops.

Move the rear stop to the back of the slot.

Remove the front stop completely and fit the sliding carriage on to the guide rail so that the four bearing guides are located in the matching grooves on each side.

Replace the front stop.



Identify the crosscut fence.

Place it with the open side face down and the plastic tip to the right.

Slide the pivot block and the locking block on to the back side of the fence with the heads of the bolts in the T-slot.

The work clamp passes through the pivot block and locates in the large hole at the front of the carriage. The clamp is then locked in place with the small grub screw in the front edge of the carriage.

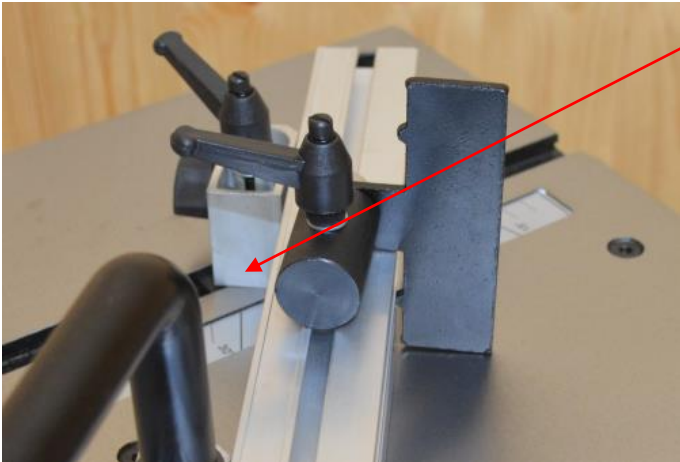

The locking block has a T-shaped foot which slides in to the slot in the sliding carriage table.

Fit the flip-over length stop by feeding the head of the bolt into the T-shaped slot on the top side of the fence.

The ratchet handle locks the stop in place.

The stop plate can be flipped over to engage or disengage it.



Push up the locating stop from below the carriage. Use a square to check the crosscut fence is set at 90 degrees to the blade.

If necessary adjust the stop by loosening the grub screw/locknut and rotating the pin insert to set the angle using a screwdriver in the slot.

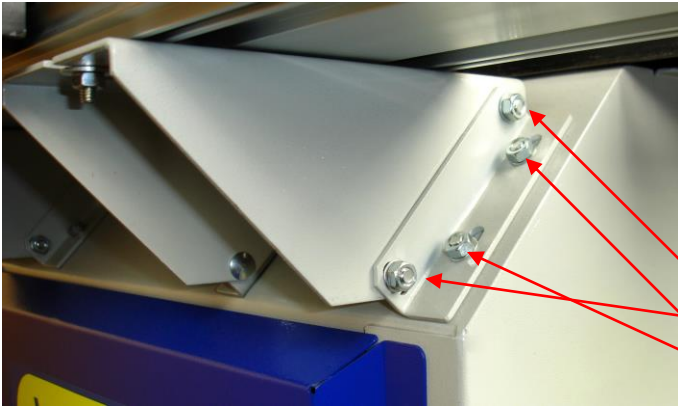

Check the sliding table is horizontally aligned with the main table. It should also be slightly higher (Up to 1mm) in order to allow a clamped workpiece to move across the main table.

Adjustment can be made by loosening the appropriate nuts/bolts holding the four mounting brackets.

#### Level Adjustment

#### Height Adjustment

The sliding mitre fence can be used on either side of the blade. Slide the T-bar into a slot in the main table.

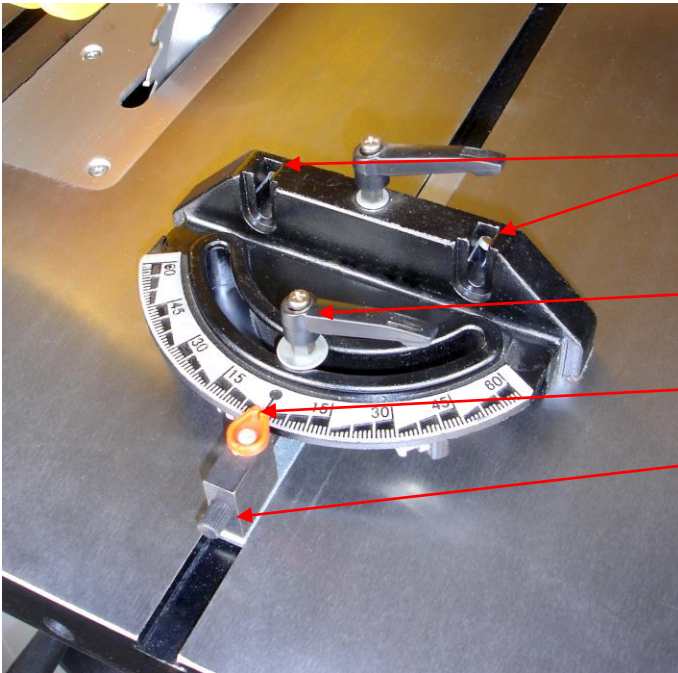

Holes are provided to allow a timber fence to be attached in order to give additional support to the workpiece.

The ratchet handles are used to lock the fence in the desired position.

Read the set angle here

Engaging the pre-set plunger allows the 3 common positions of 90 degrees, 45 left and 45 right to be quickly and accurately set.

The positions can be fine tuned using the appropriate screw/locknuts situated below the scale.



Place one hand wheel on the spindle protruding from the front of the saw.

Rotate it so that the locking screw is in line with the flat on the spindle and tighten the screw.

This wheel controls the rise and fall of the blade.

Turn clockwise to raise the blade.

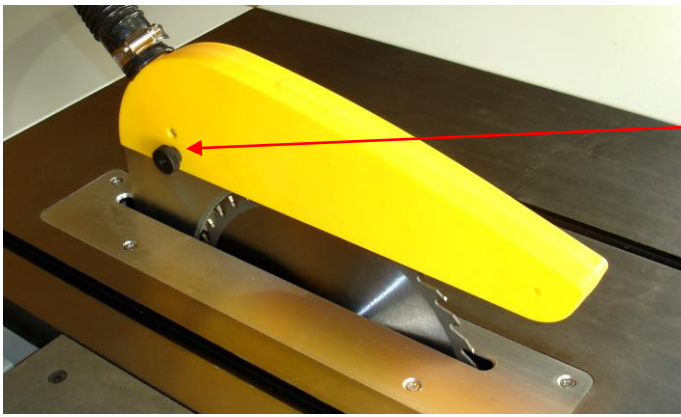

Raise the blade, loosen the nut and bolt in the crown guard and fit it over the riving knife.

Tighten the black nut so that the guard is secure.

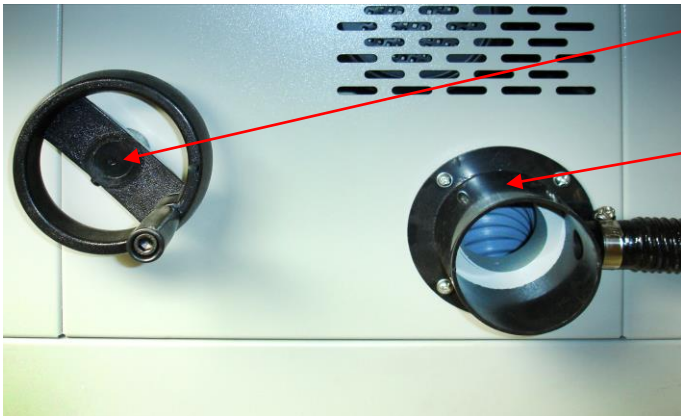

Fit the second hand wheel to the spindle protruding from the right hand side of the saw. This controls the blade angle.

Remove the four screws by the dust extraction outlet and use them to fix the 100mm hose connector.

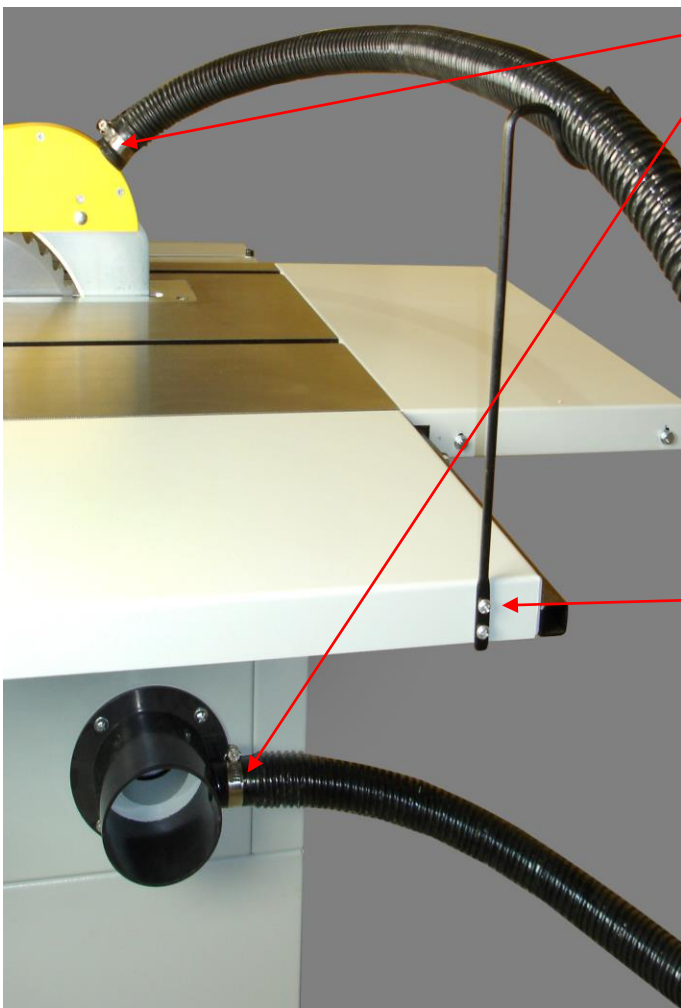

Connect one end of the extraction hose to the crown guard and the other end to the branch on the dust outlet using the hose clamps.

Using the two screws and nuts provided, attach the hose hook through the two holes in the side of the extension table. Clip in the hose, as shown, so that it is clear of the table and will not foul any timber that is being cut.

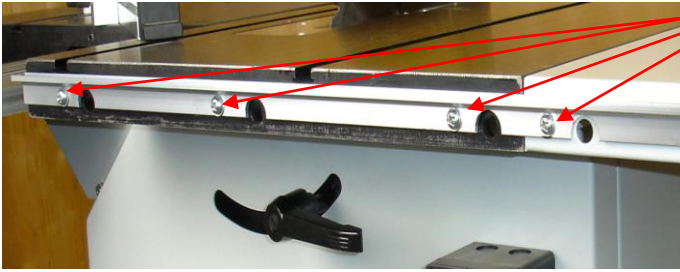

Using the five bolts in the front of the table, attach the rip fence measuring scale.

Place the long fence against the right hand side of the saw blade, so that it projects over the measuring scale. Ensure that Zero on the scale is in line with the left hand edge of the long fence.

Then tighten the bolts.



Take the rip fence guide rail and remove one nut and washer from each of the studs.

Place the studs through the holes in the front of the table and replace the nuts and washers.



This double nut arrangement can be used to fine tune the alignment of the rip fence, so that it runs parallel to the blade.

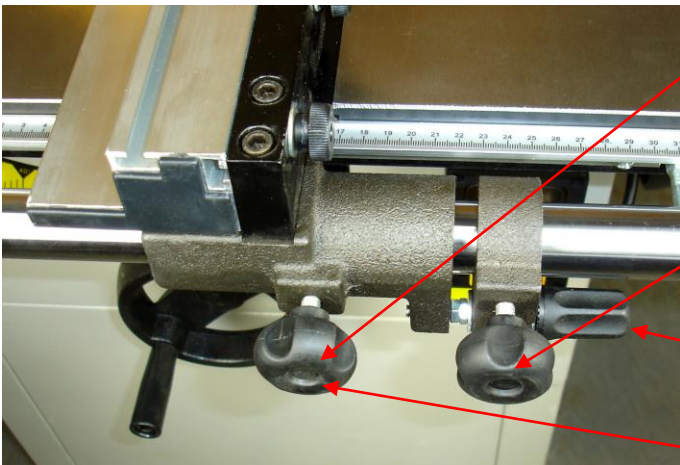

Slide the rip fence onto the guide rail. The fence can be locked into position with this locking knob.

A micro adjustment system is also provided:

Slide the fence into the approximate position required, but do not lock the main locking knob, instead lock the micro adjuster knob.

Use the micro adjuster screw to guide the fence to the exact position that you want.

Lock the fence in position with the main locking knob.

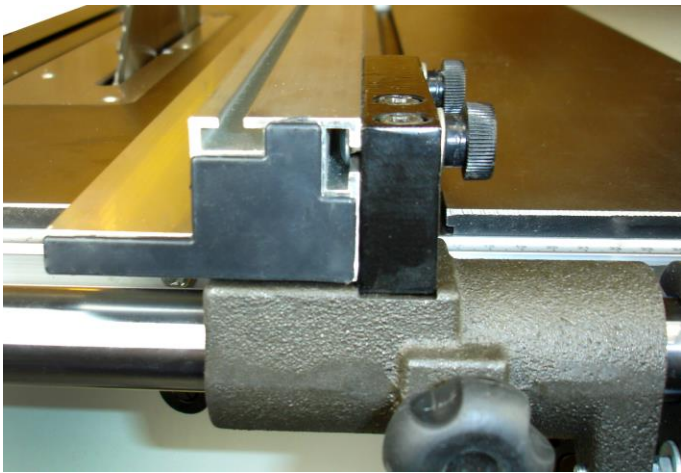

The rip fence may be fitted in 2 positions:

The low position is used when cutting narrow material, close to the blade, to avoid the fence catching on the crown guard.

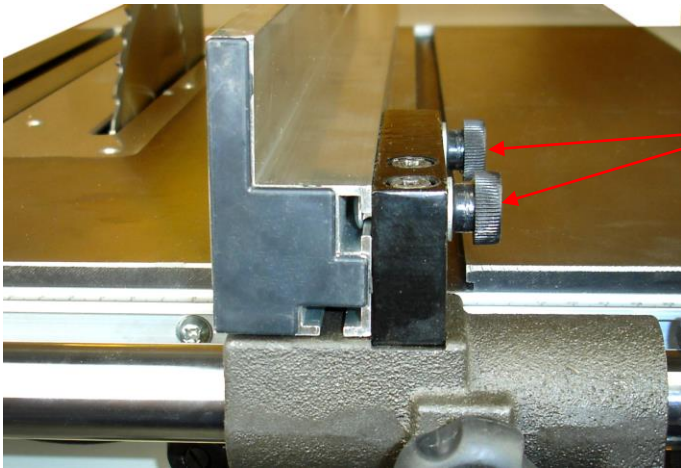

The high position is the standard position, used for general cutting.

To change between the two, slacken these two knurled nuts, slide the aluminium extrusion off and replace it in the desired position.

## Changing the Blade

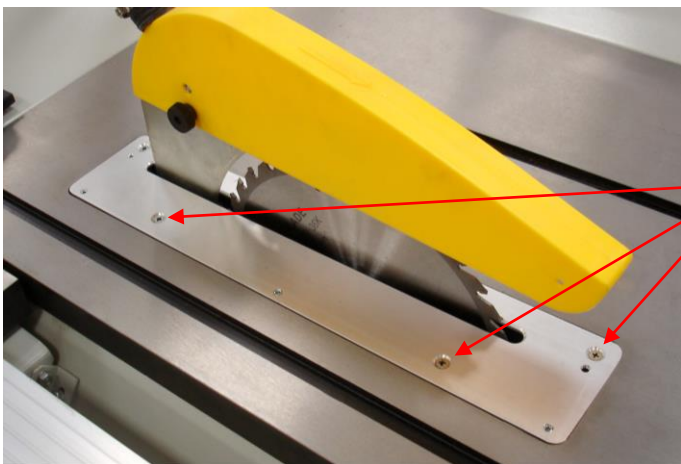

Unplug the saw from the power source.

Raise the blade height to its maximum and remove the crown guard.

Undo the five screws securing the table insert and remove it.



By hand, rotate the blade until the hole in the collar on the right hand side of the blade can be accessed.

Insert the end of the tommy bar into the hole to act as a spindle lock.



Use the 17mm spanner provided to unlock the nut on the saw spindle. Remove the nut, the washer, the saw flange and the blade.

**Please Note: The Nut is Left Hand Thread (Turn clockwise to undo)**

## Riving Knife Adjustment

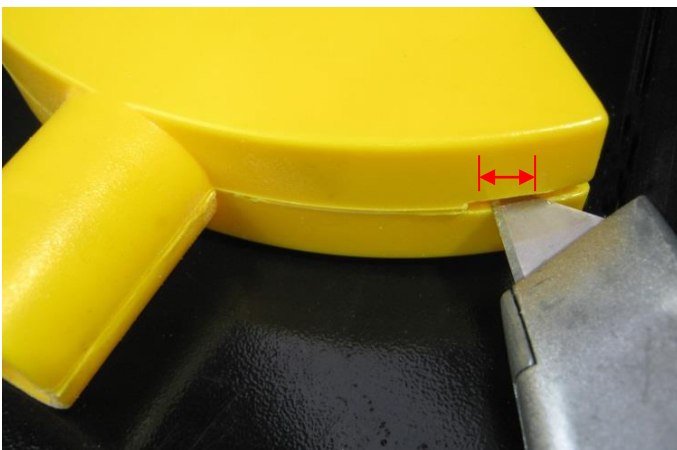

It is possible that the factory setting of the riving knife restricts the maximum cutting depth of the saw. If this is the case, the riving knife can be adjusted as follows:

Ensure that the machine is isolated from the power supply.

Raise the blade to its maximum height using the blade height adjustment hand wheel at the front of the saw.

Remove the hose from the crown guard, remove the crown guard from the riving knife, by loosening the black thumb screw.



In order to keep the Crown Guard parallel to the table once the riving knife has been adjusted, a slight modification will need to be made to the slot.

This allows the crown guard to rotate further on the pivot point and remain parallel to the table after the adjustment.

Use a sharp craft knife to carefully extend the slot at the rear of the guard by approximately 7mm. You might find this easier if the two sides of the guard are first split.

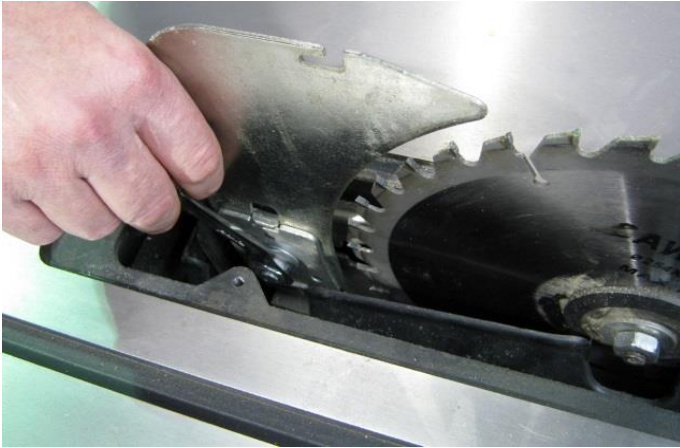

Remove the five recessed head screws from the table insert using a screwdriver.

Lift out the insert.

The nut holding the riving knife can now be loosened using a 16mm spanner.

Raise the riving knife and crown guard assembly, so that the crown guard is situated just above the top of the saw blade. If necessary, adjust the riving knife so that there is an even gap between the leading edge of the riving knife and the radius of the saw blade. Adjust the crown guard so that it is parallel to the table.

Re-tighten the bolt.

Replace the table insert and screws.

The saw can now be used to its full cutting capacity.

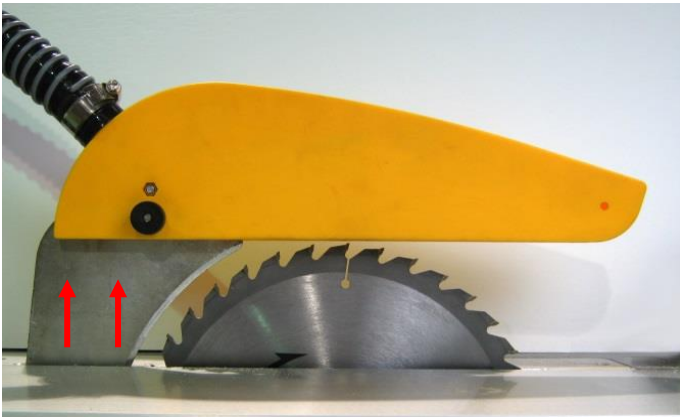



# Maintenance

The following adjustments are all factory set when you buy a new saw. During the life of the machine it may be necessary to make some minor adjustments using the following guidance.

## Aligning The Blade To The Table Mitre T-Slot

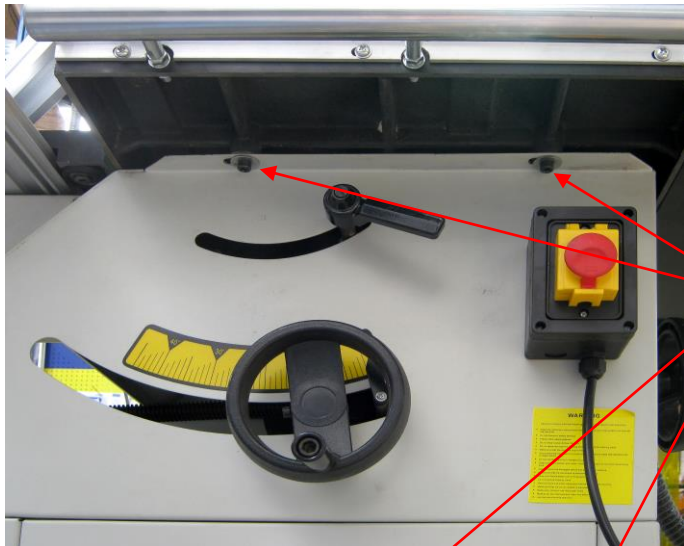

Disconnect the saw from the power supply and remove the blue panel from side of the saw base.

Loosen, but do not fully undo, the four M8 hex cap head bolts under the front and rear of the cast table using a 6mm hex key.

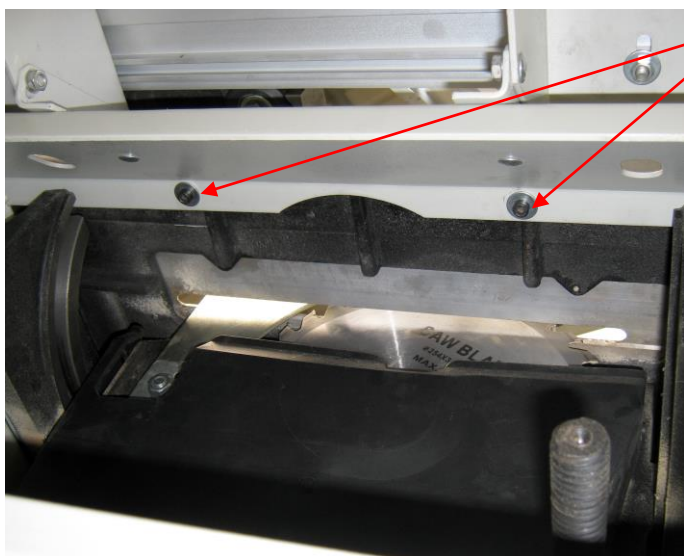
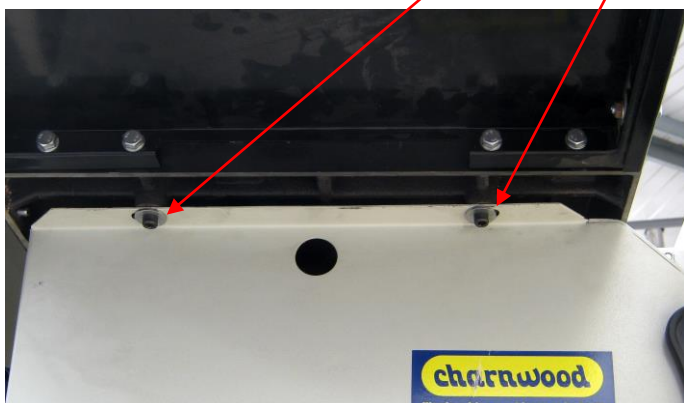

Next, using a 5mm hex key, loosen the two cap head bolts accessed through the side of the base under the sliding table.

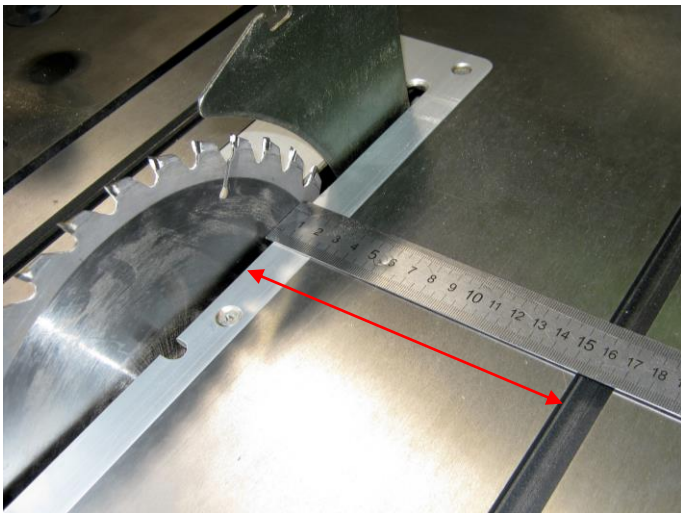

Adjust the alignment of the sawblade to the table mitre T slot by moving the cast iron table over the base.

Measure the distance between the blade and the table T slot at both the front and rear of the blade.

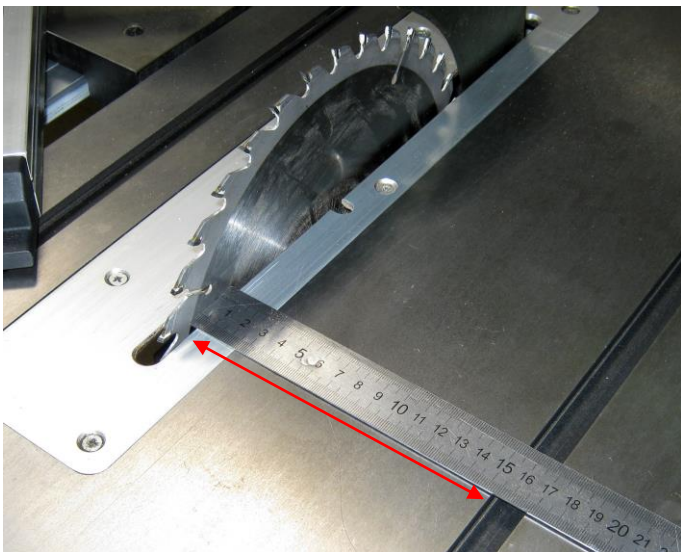

When both measurements are the same, ensure that the blade is running free and will clear the table insert when the blade is tilted to 45 degrees.

When you are satisfied the blade is aligned, tighten the six bolts and replace the side panel prior to use.

## Adjusting The Blade Angle Stops



Locate the adjustable bolt fitted to the slot in the saw trunnion. This can be accessed through the tilt locking handle slot on the front of the machine.

Loosen the bolt, using a 6mm Allen key, and tilt the blade accurately to 45 degrees. Retighten the bolt ensuring that it is positioned as far to the right as possible.

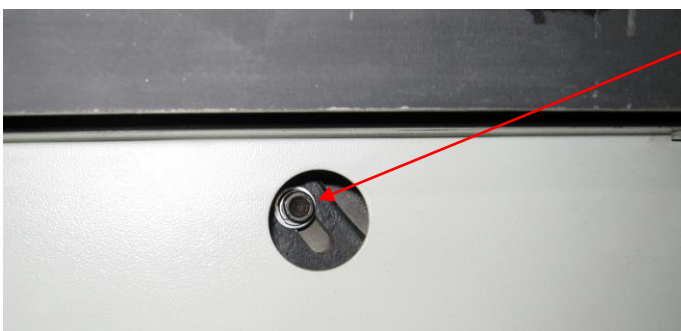

There is a similar Limit Stop for the 90 degree setting which is accessed through a hole at the rear of the machine.

# Troubleshooting

Saw vibrates	Check all nuts and bolts for tightness and check that blade is not damaged.
Cuts are slow, wood is blackened	Examine the blade. If any Tungsten tips are missing or broken the blade should be replaced. If the tips are blunt, the saw blade may to be professionally sharpened.
Saw stalls	Feed rate too high, slow down.
Rip fence is not parallel to blade	Bring the fence up to the blade and re-align the fence so it is parallel, by adjusting the 5 fixing studs which hold the round guide rail onto the table.
Lower saw guard fills with dust	It is essential to use a vacuum extractor or chip collector with this machine. If one is being used, check for blockages in the hose.
When pressing start, nothing happens	Check power supply, fuse in plug and switch.

## Declaration of Conformity



Charnwood Declare that Woodworking Circular Saw, Model W650

Conforms with the following EU Directives: Machinery Directive 2006/42/EC  
Low Voltage Directive 2006/95/EC

Conforms with the following UK Regulations: Supply of Machinery (Safety) Regulations 2008  
Electrical Equipment (Safety) Regulations 2016

And further conforms to the machinery example for which the type examination Certificate No. BM 50188738, AN 50188739 have been issued by TUV Rheinland LGA Products GmbH, Tillystrasse 2, 90431, Nurnberg.

I hereby declare that equipment named above has been tested and found to comply with the relevant sections of the above referenced specifications. The machinery complies with all essential requirements of the directives and regulations.

Signed:  Dated: 01/10/2020 Location: Leicestershire

Richard Cook, Director



Please dispose of packaging for the product in a responsible manner. It is suitable for recycling. Help to protect the environment, take the packaging to the local amenity tip and place into the appropriate recycling bin.

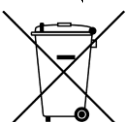

Only for EU countries

Do not dispose of electric tools together with household waste material!

In observance of European Directive 2002/96/EC on waste electrical and electronic equipment (EEE) and its implementation in accordance with national law, electric tools that have reached the end of their life must be collected separately and returned to an environmentally compatible recycling facility.

Your local refuse amenity will have a separate collection area for EEE goods.

# CHARNWOOD W650 PARTS DIAGRAM A

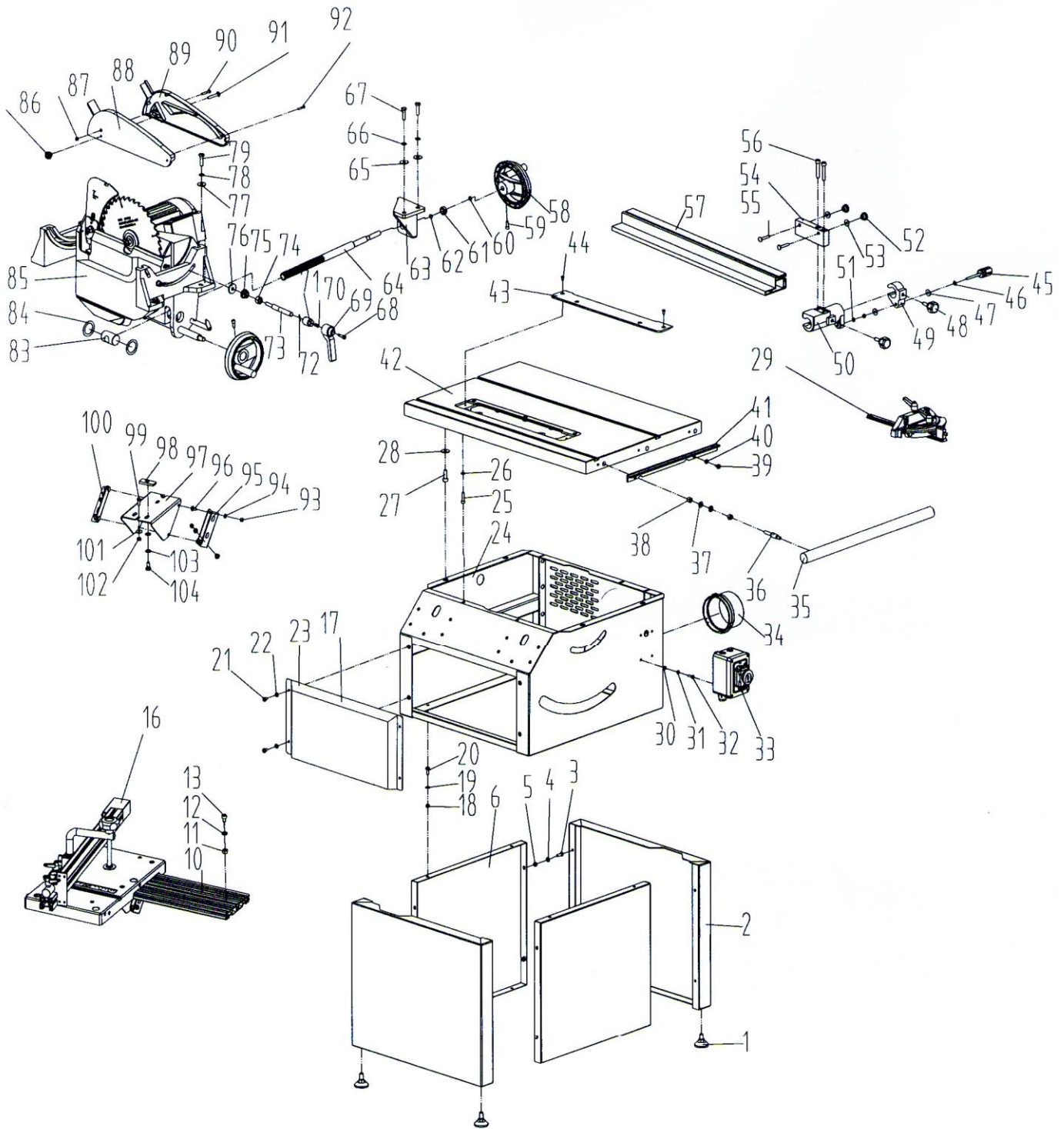

## CHARNWOOD W650 PARTS LIST A

Part No.	Description	Part No.	Description
A001	Underprop	A002	Lower Leg
A003	Hex Bolt M6 x 16mm	A004	Washer M6
A005	Hex Nut M6	A006	Cover Board
A010	Guide Rail	A011	Hex Nut M8

A012	Washer M8	A013	Screw M8 x 10mm
A016	Sliding Table Assembly.	A017	Protective Cover
A018	Hex Nut M6	A019	Washer M6
A020	Hex Bolt M6 x 16mm	A021	Screw M6 x 10mm
A022	Washer M6	A023	Large Washer M6
A024	Box Assembly	A025	Screw M6 x 25mm
A026	Washer M6	A027	Screw M8 x 25mm
A028	Large Washer M8	A029	Mitre Gauge Assembly
A030	Hex Nut M5	A031	Washer M5
A032	Hex Bolt M5 x 16mm	A033	Switch Assembly
A034	Suction Tube	A035	Leader Pole
A036	Dual Head Bolt	A037	Washer M8
A038	Hex Nut M8	A039	Screw M6 x 10mm
A040	Washer M6	A040	Washer
A041	Ruler Support	A042	Table
A043	Insert	A044	Screw M5 x 10mm
A045	Micro Adjust Handle	A046	Wave Washer M6
A047	Large Washer M6	A048	Locking Handle
A049	Micro Adjust Support	A050	Clamp
A051	Thin Hex Nut M6	A052	Locking Button
A053	Large Washer M6	A054	Linking Plate
A055	Square Neck Bolt M6 x 35	A056	Screw M8 x 45mm
A057	Fence	A058	Hand Wheel
A059	Screw M6 x 16mm	A060	'C'Ring 12mm
A061	Bearing GE12E	A062	'C'Ring 22mm
A063	Bracket	A064	Thread Spindle
A065	Large Washer M8	A066	Spring Washer M8
A067	Hex Bolt M8 x 65mm	A068	Screw
A069	Locking Handle	A070	Spring
A071	Locking Bush	A072	Spring Pin 3 x 20mm
A073	Locking Spindle	A074	Hex Nut M12
A075	Hex Flange Nut M12	A076	Large Washer M8
A077	Large Washer M8	A078	Spring Washer M8
A079	Hex Bolt M8 x 65mm	A080	Screw M8 x 12mm
A081	Dentiform Washer M8	A082	Washer M8
A083	Thread Nut	A084	Plastic Washer
A085	Saw Assembly	A086	Locking Button
A087	Locking Nut M5	A088	Blade Guard
A089	Blade Guard	A090	Screw M5 x 30mm
A091	Square Neck Bolt M6 x 40mm	A092	Screw M3.5mm x 25mm
A093	Hex Nut M6	A094	Washer M6
A095	Right Supporting Plate	A096	Screw M6 x 12mm
A097	Rail Support	A098	Locating Block
A099	Hex Bolt M6 x 16mm	A100	Left Supporting Plate
A101	Large Washer M6	A102	Hex Nut M6
A103	Hex Nut M6	A104	Hex Bolt M8 x 10mm

## CHARNWOOD W650 PARTS DIAGRAM B

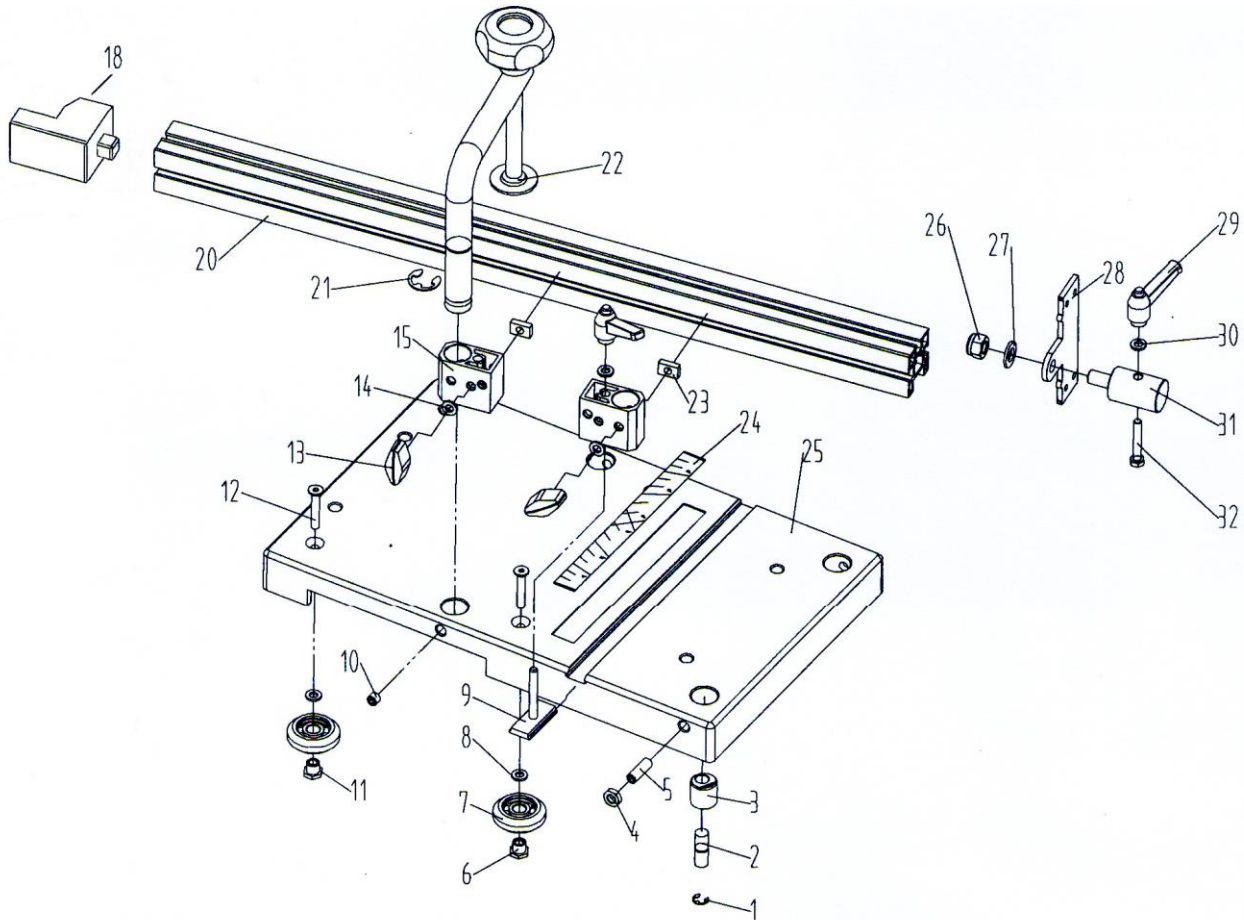

## CHARNWOOD W650 PARTS LIST B

Part No.	Description	Part No.	Description
B001	'C' Wire Ring	B002	Sliding Axle
B003	Eccentric Bush	B004	Thin Hex Nut M8
B005	Grub Screw M8 x 25mm	B006	Eccentric Nut
B007	Trolley	B008	Washer M6
B009	T-Shaped Bolt	B010	Grub Screw M8 x 10mm
B011	Homocentric Nut	B012	Socket C/S Screw M6 x 35mm
B013	Rhombic Handgrip	B014	Washer M6
B015	Connecting Block	B018	Plastic End Block
B020	Angle Fence Extrusion	B021	'E' Ring 12mm
B022	Press Handle	B023	Square Nut
B024	Angle Ruler	B025	Sliding Table
B026	Nyloc Nut M10	B027	Washer M10
B028	Length Stop Plate	B029	Ratchet Handle
B030	Washer M6	B031	Stop Block
B032	Hex Bolt M6 x 35mm		

## CHARNWOOD W650 PARTS DIAGRAM C

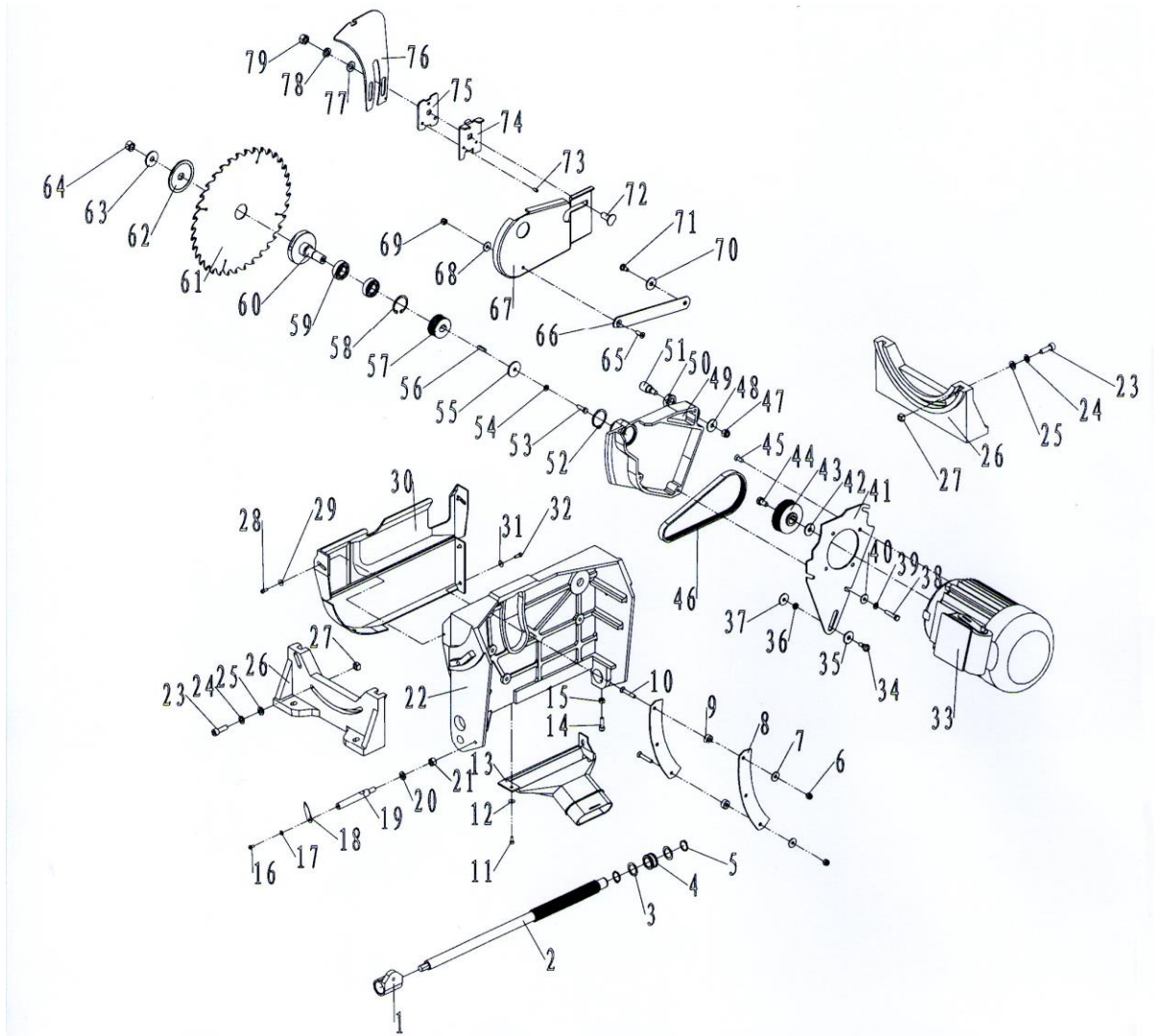

## CHARNWOOD W650 PARTS LIST C

Part No.	Description	Part No.	Description
C001	Thread Nut	C002	Thread Spindle
C003	Bush Washer	C004	Bush
C005	'C' Ring 8mm	C006	Hex Locking Nut M6
C007	Large Washer M6	C008	Limited Plate
C009	Space Bush	C010	Screw M6 x 35mm
C011	Screw M4 x 10mm	C012	Large Washer M4
C013	Compressed Dust Collector	C014	Screw M6 x 20mm
C015	Hex Nut M6	C016	Screw M4 x 8mm
C017	Washer M4	C018	Pointer
C019	Pointer Support	C020	Washer M8
C021	Hex Nut M8	C022	Circumrotate Bracket
C023	Screw M8 x 25mm	C024	Spring Washer M8
C025	Washer M8	C026	Circumrotate Support
C027	Square Nut	C028	Screw M4 x 10mm
C029	Large Washer M4	C030	Dust Collector

C031	Large Washer M4	C032	Screw M4 x 12mm
C033	Motor	C034	Sliding Bolt
C035	Large Washer M8	C036	Sliding Bush
C037	Large Washer M8	C038	Hex Bolt M6 x 30mm
C039	Spring Washer M6	C040	Large Washer M6
C041	Motor supporting Plate	C042	Large Washer M8
C043	Motor Pulley	C044	Hex Bolt M8 x 16mm LH
C045	Screw M6 x 16mm	C046	Cuneal Belt
C047	Hex Locking Nut M8	C048	Large Washer M8
C049	Circumrotate Plate	C050	Thin Hex Nut M16
C051	Thread Bolt	C052	'C' Ring 32mm
C053	Hex Bolt M6 x 20mm	C054	Spring Washer M6
C055	Large Washer	C056	Key 5 x 20mm
C057	Driven Pulley	C058	'C' Ring 35mm
C059	Bearing 6003	C060	Saw Axis
C061	Saw Blade	C062	Platen
C063	Large Washer	C064	Hex Nut M10 LH
C065	Screw M6 x 16mm	C066	Linking Plate
C067	Parallel Plate	C068	Large Washer
C069	Hex Locking Nut M6	C070	Large Washer M8
C071	Pin	C072	Square Neck Bolt M10 x 25mm
C073	Set Screw M5 x 10mm	C074	Interior Clamp Plate
C075	Outer Clamp Plate	C076	Riving Wedge
C077	Washer M10	C078	Spring Washer M10
C079	Hex Nut M10		

Updated October 2020

**Charnwood, Cedar Court, Walker Road, Hilltop Industrial Estate,  
Bardon Hill, Leicestershire, LE67 1TU**

**Tel. 01530 516 926 Fax. 01530 516 929  
email: [sales@charnwood.net](mailto:sales@charnwood.net) website: [www.charnwood.net](http://www.charnwood.net)**