

610856

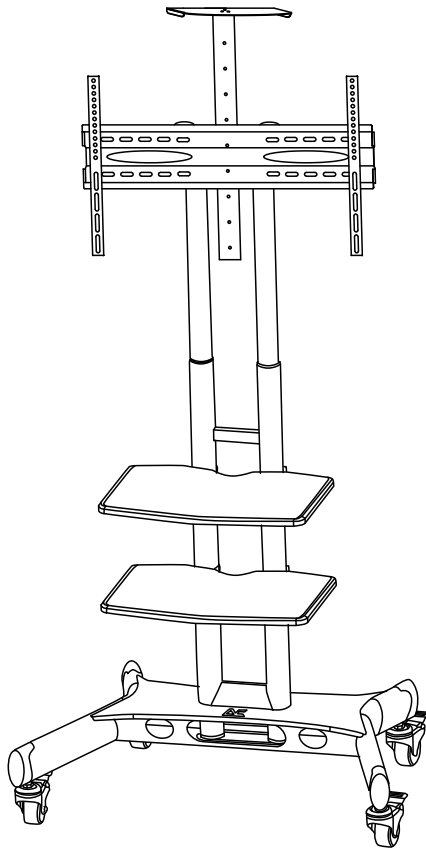

- EN** - Please read this instruction manual carefully before attempting to install.  
**DE** - Bitte lesen Sie diese Bedienungsanleitung vor der Montage gründlich durch.  
**ES** - Por favor lea con atención el manual de instrucciones antes de llevar a cabo el ensamble.  
**FR** - Lisez attentivement cette notice avant de commencer le montage.  
**IT** - Si prega di consultare il libretto delle istruzioni prima del montaggio.

# IMPORTANT/WICHTIG/ATENCIÓN

## IMPORTANT/IMPORTANTE



EN - We recommend **1** or more people to install.  
DE - Wir empfehlen, dass die Montage von **1** oder mehreren Personen durchgeführt werden sollte.  
ES - Recomendamos realizar el ensamble con **1** o más personas.  
FR - Il est recommandé d'effectuer le montage à **1** personne(s) ou plus.  
IT - È necessaria la presenza di **1** o più persone per il montaggio di questo prodotto.



EN - The expected assembly time is **1 h**.  
DE - Die Montagezeit beträgt durchschnittlich **1 h**.  
ES - El tiempo aproximado de ensamble es de **1 h**.  
FR - Le temps nécessaire est estimé à **1 h**.  
IT - Il tempo previsto per il corretto assemblaggio è di **1 h**.



EN - Not intended for use by children.  
DE - Nicht geeignet für Kinder.  
ES - Producto no apto para niños.  
FR - Produit non destiné à être utilisé par des enfants.  
IT - Questo prodotto non è destinato all'uso da parte dei bambini.



EN - Keep away from fire or other heat sources.  
DE - Bitte von Feuer und Hitzequellen fernhalten.  
ES - Manténgase alejado de las llamas y otras fuentes de calor.  
FR - Tenir à distance des flammes et autres sources de chaleur.  
IT - Tenere lontano dal fuoco o da altre fonti di calore.



EN - We recommend wearing protective gloves.  
DE - Wir empfehlen das Tragen von Schutzhandschuhen.  
ES - Recomendamos el uso de guantes de seguridad.  
FR - Il est recommandé de porter des gants de protection.  
IT - Per il processo di assemblaggio, consigliamo fortemente l'utilizzo di guanti protettivi.



EN - Please contact us via **help@yaheetech.shop** if you need assistance.  
DE - Bitte kontaktieren Sie unseren Kundenservice per E-Mail: **help@yaheetech.shop** für weitere Hilfe.  
ES - Si necesita ayuda, por favor póngase en contacto con nosotros a través de **help@yaheetech.shop**.  
FR - Besoin d'aide? Contactez-nous via **help@yaheetech.shop**.  
IT - Per assistenza o maggiori informazioni, puoi contattarci all'indirizzo mail **help@yaheetech.shop**.

**EN** - Please follow the instruction manuals and use a pad to avoid damage during assembly.







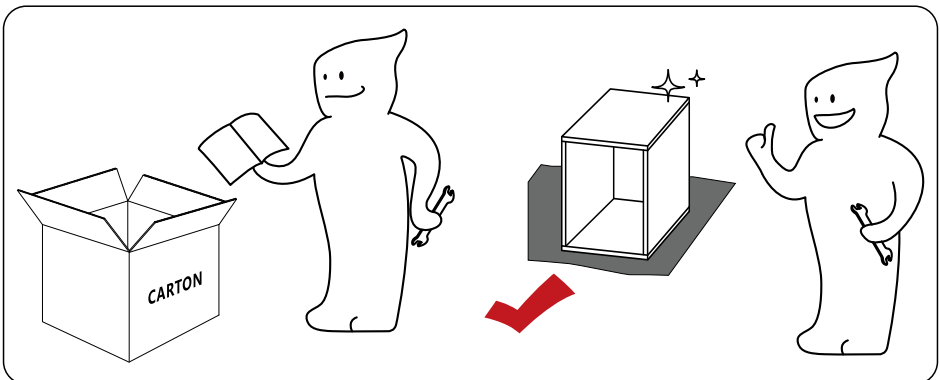
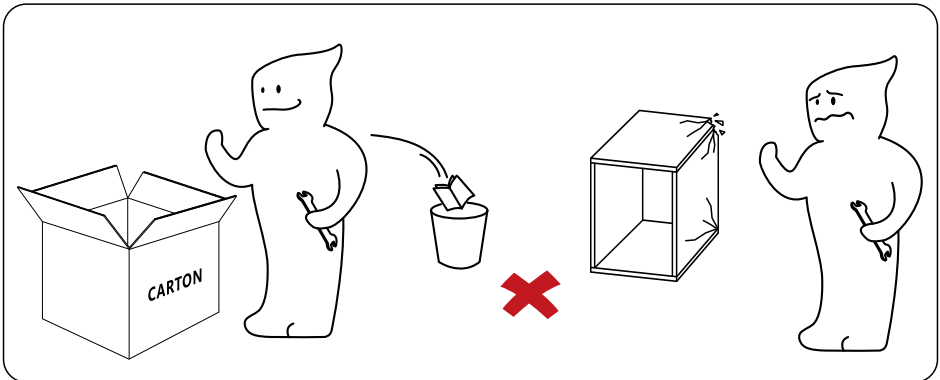

**DE** - Bitte folgen Sie der Anleitung und verwenden Sie eine Unterlage, um Beschädigungen bei der Montage zu vermeiden.

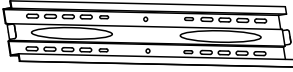

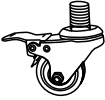
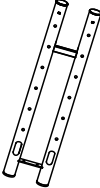

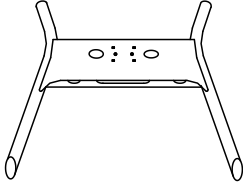
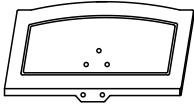
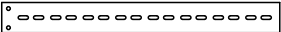



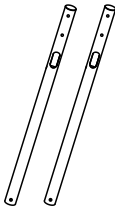

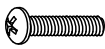
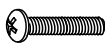

**ES** - Por favor siga las instrucciones del manual y utilice una cubierta o lona para proteger el producto y los suelos durante la instalación.

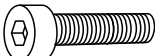
**FR** - Suivez les instructions de la notice et utilisez une couverture ou une bâche pour protéger le produit et les sols pendant le montage.

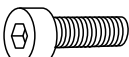

**IT** - Si prega di consultare il manuale illustrativo durante il montaggio e di utilizzare un cuscinetto per evitare possibili danni.

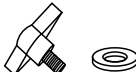

<p>① x 1</p> 	<p>② x 1</p> <p>L</p> 	<p>③ x 1</p> <p>R</p> 
<p>④ x 4</p> 	<p>⑤ x 1</p> 	<p>⑥ x 4</p> 
<p>⑦ x 2</p> 	<p>⑧ x 1</p> 	<p>⑨ x 1</p> 
<p>⑩ x 1</p> 	<p>⑪ x 2</p> <p>L</p> 	<p>⑫ x 2</p> <p>R</p> 
<p>⑬ x 4</p> 	<p>⑭ x 1</p> 	<p>⑮ x 2</p> 

<p>Ⓐ x 4</p>  <p>M8*25mm</p>	<p>Ⓑ x 4</p>  <p>M6*25mm</p>	<p>Ⓒ x 4</p>  <p>M5*25mm</p>	
<p>Ⓓ x 8</p>  <p>6mm</p>	<p>Ⓔ x 18</p>  <p>8mm</p>	<p>Ⓕ x 4</p>  <p>15mm</p>	
<p>Ⓖ x 4</p>  <p>16mm</p>	<p>Ⓗ x 4</p>  <p>M8*30mm</p>	<p>Ⓖ x 4</p>  <p>M8*60mm</p>	
<p>Ⓙ x 4</p>  <p>M8*20mm</p>	<p>Ⓚ x 4</p>  <p>M6*12mm</p>	<p>Ⓛ x 4</p>  <p>M8</p>	
<p>Ⓜ x 4</p>  <p>M6</p>	<p>Ⓝ x 2</p> 	<p>Ⓞ x 1</p> 	<p>Ⓟ x 1</p> 

1

④		x4
⑧		x1

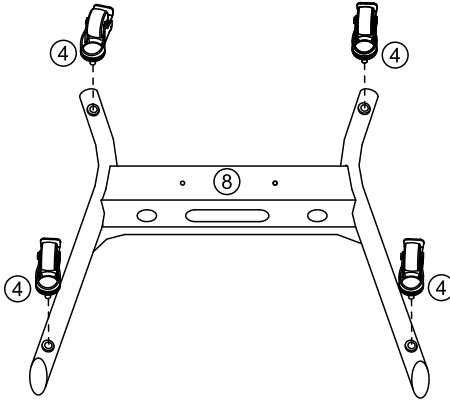

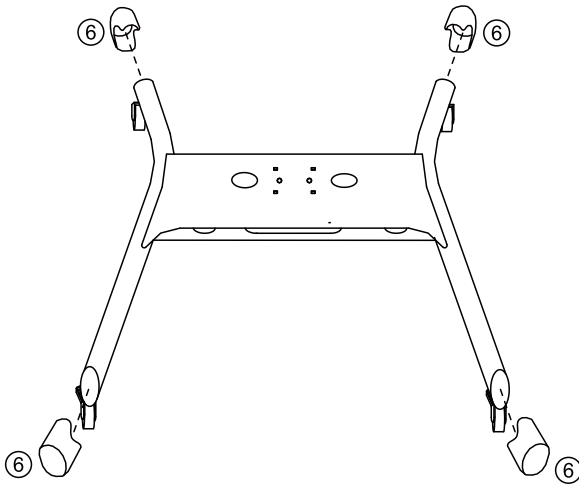

2

⑥		x4
---	---	----



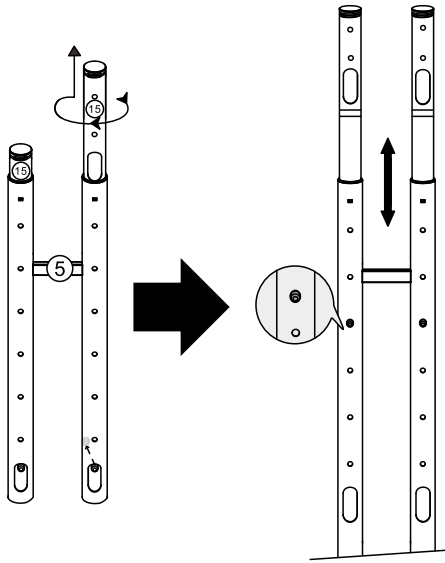

3

⑤		x1
⑮		x2



4

ⓐ		x4
ⓔ		x4

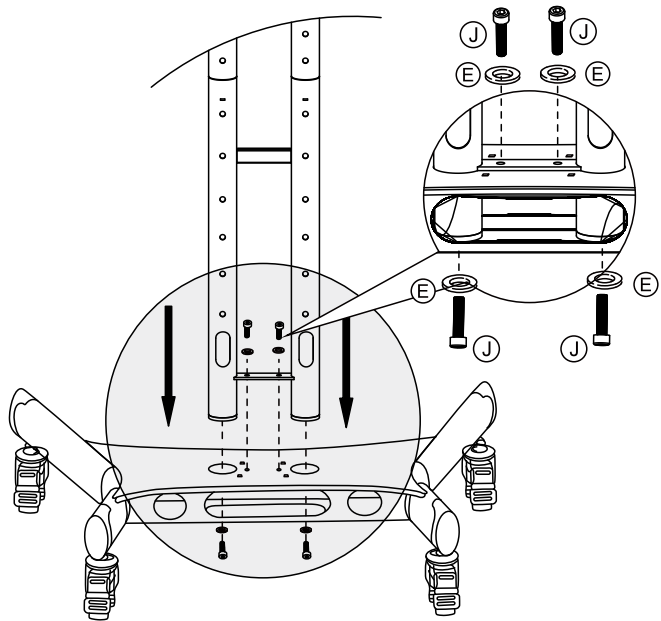

5

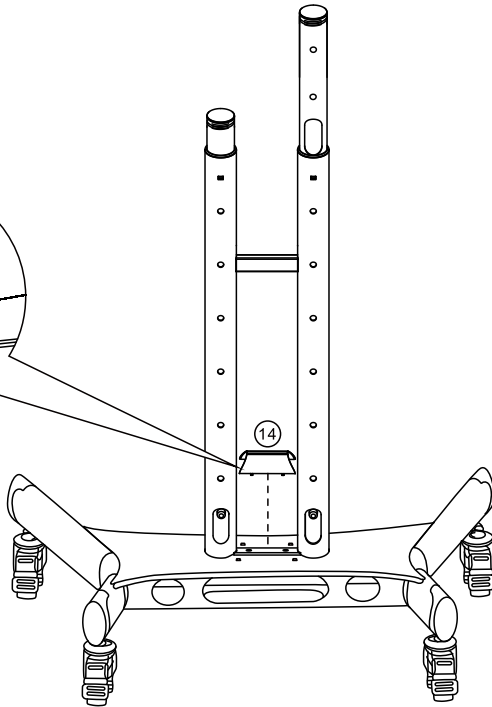
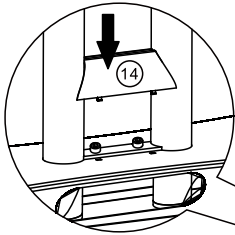
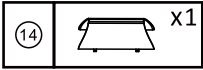

6

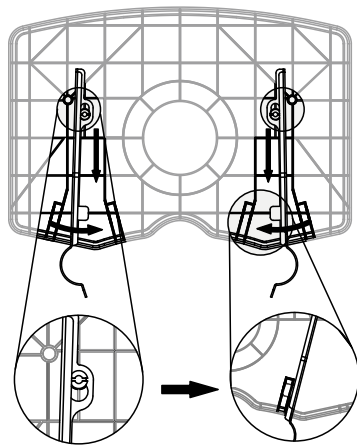
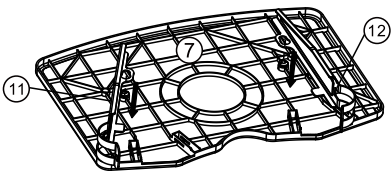
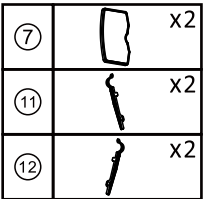





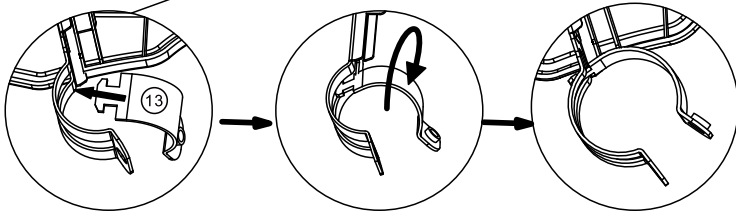
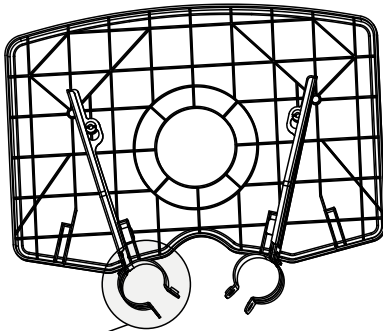

7

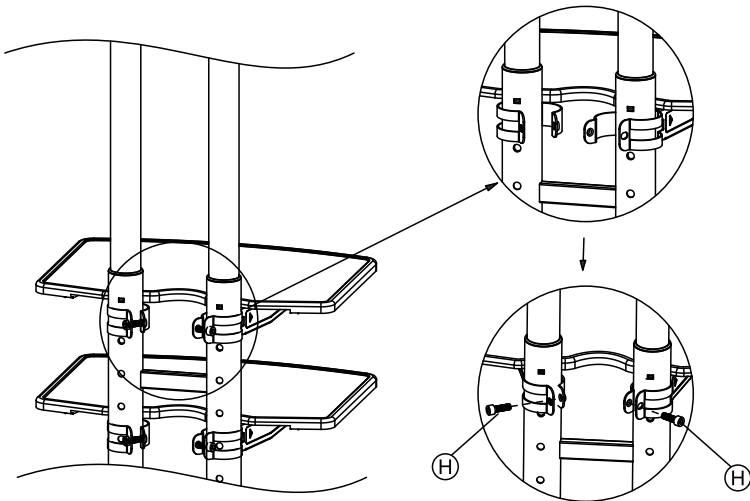
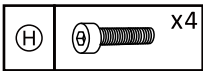

8





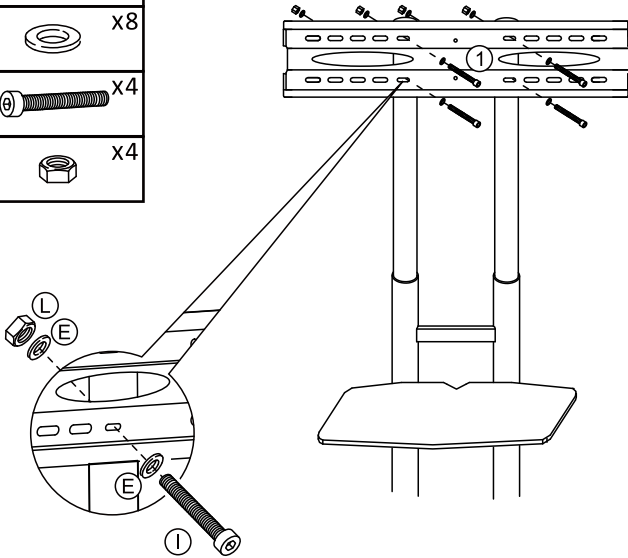

9

①		x1
E		x8
I		x4
L		x4

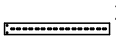

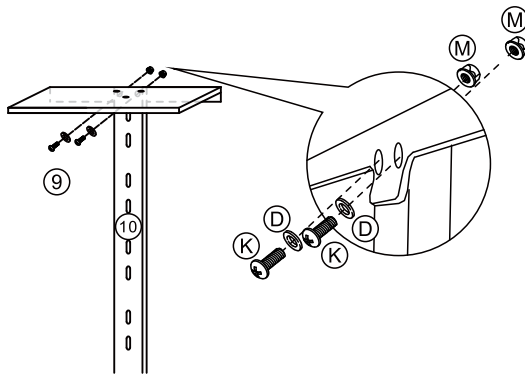

10

⑨		x1
⑩		x1
D		x2
K		x2
M		x2



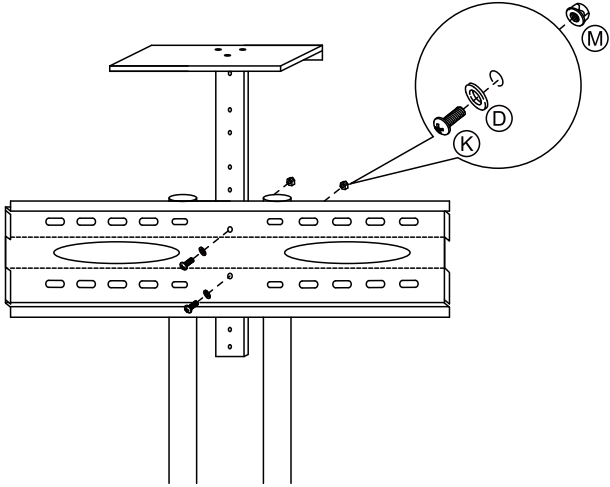

# 11

(D)		x2
(K)		x2
(M)		x2



# 12

(2)		x1
(3)		x1
(N)		x2

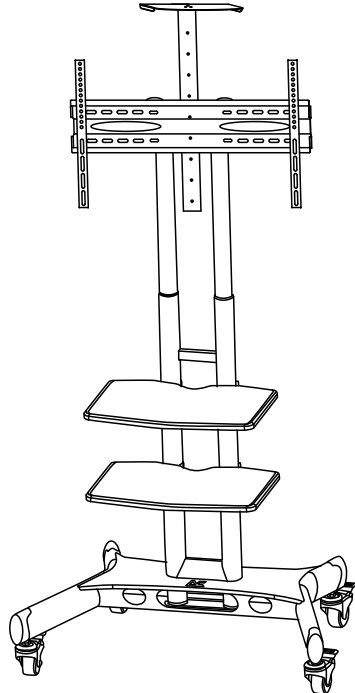
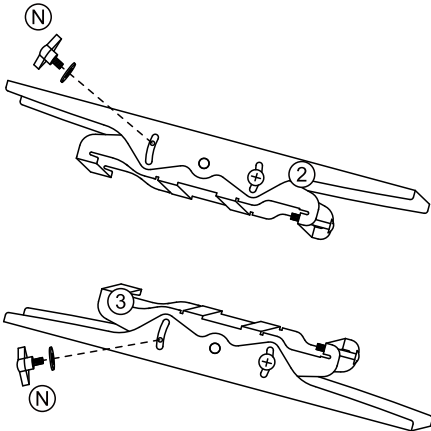

1

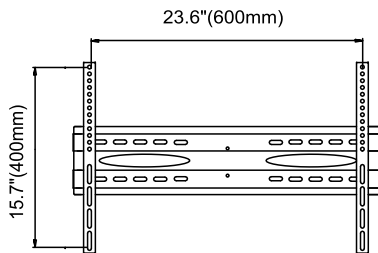
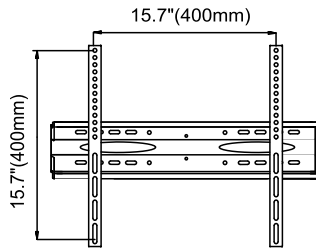
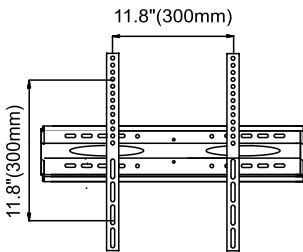
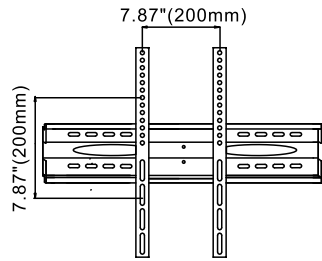
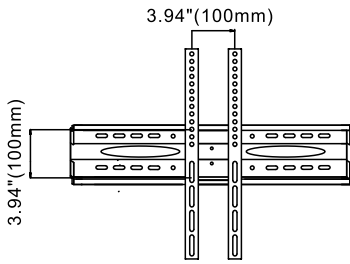

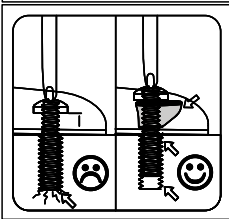
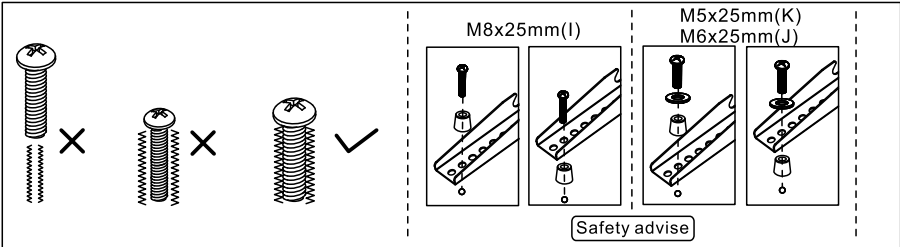
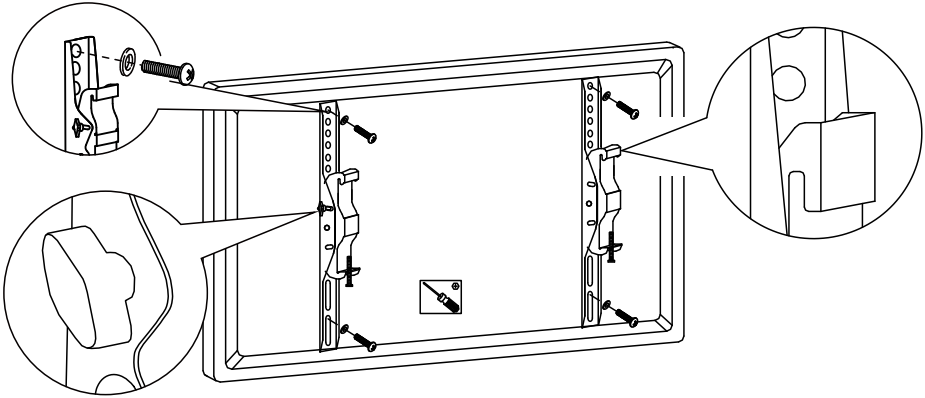

**EN** - Tighten all screws but do not OVER tighten.

TV must NOT exceed 110lbs.

3 different types of screws( I ,J, K) are provided for assembling arms to TV.

Please kindly use the appropriate ones which are suitable for your TV.

If provided screws are not suitable, you can purchase these from your local hardware shops.

Note: To avoid damage plastic spacer must be used when the mounting hole is not deep enough.

**DE** - Ziehen Sie alle Schrauben fest, aber nicht ZU fest an.

Der Fernseher darf NICHT schwerer als 50 kg sein.

vier verschiedene Schraubengrößen (I ,J, K ) werden für die Befestigung der Arme am Fernseher mitgeliefert.

Sollten die mitgelieferten Schrauben dennoch für Ihr Gerät nicht passend sein, können Sie diese in örtlichen Eisenwarengeschäften kaufen.

Hinweis: Der mitgelieferte Kunststoffabstandshalter sollte verwendet werden, um Beschädigungen zu vermeiden wenn die Montagebohrung nicht tief genug ist

**ES** - Apriete todos los tornillos pero no los apriete en exceso.

El televisor no debe superar las 110 libras ( 50kg )

Se suministran 3 tipos diferentes de tornillos (I,J,K) para el montaje de los brazos en el televisor.

Por favor, utilice los que sean adecuados para su televisor. Si los tornillos suministrados no son adecuados, puede conseguirlos en las ferreterías locales.

Nota: Para evitar daños, se debe utilizar un espaciador de plástico cuando el orificio de montaje no es lo suficientemente profundo.

**FR** - Serrez toutes les vis mais ne les serrez pas trop fort/ trop profondément.

Le poids du téléviseur ne doit pas dépasser 50 kg.

3 types de vis (I,J,K) sont fournis pour fixer les bras sur le téléviseur. Choisissez celles qui conviennent pour votre appareil.

Si aucune des vis fournies ne convient, vous pouvez en trouver dans votre magasin de bricolage.

Attention : il est important d'utiliser des séparateurs en plastique si le trou n'est pas assez profond.

**IT** - Stringere tutte le viti ma non forzare.

La TV non deve eccedere i 50 kg.

Sono fornite tre differenti tipi di viti (I, J, K) per collegare i bracci alla TV.

Si prega di usare le viti adatte alla tua TV.

Se le viti fornite non sono adatte, puoi recarti al ferramenta più vicino.

Nota: Al fine di evitare danni, il distanziale in plastica deve essere usato quando la fessura di supporto non è abbastanza profonda.

3

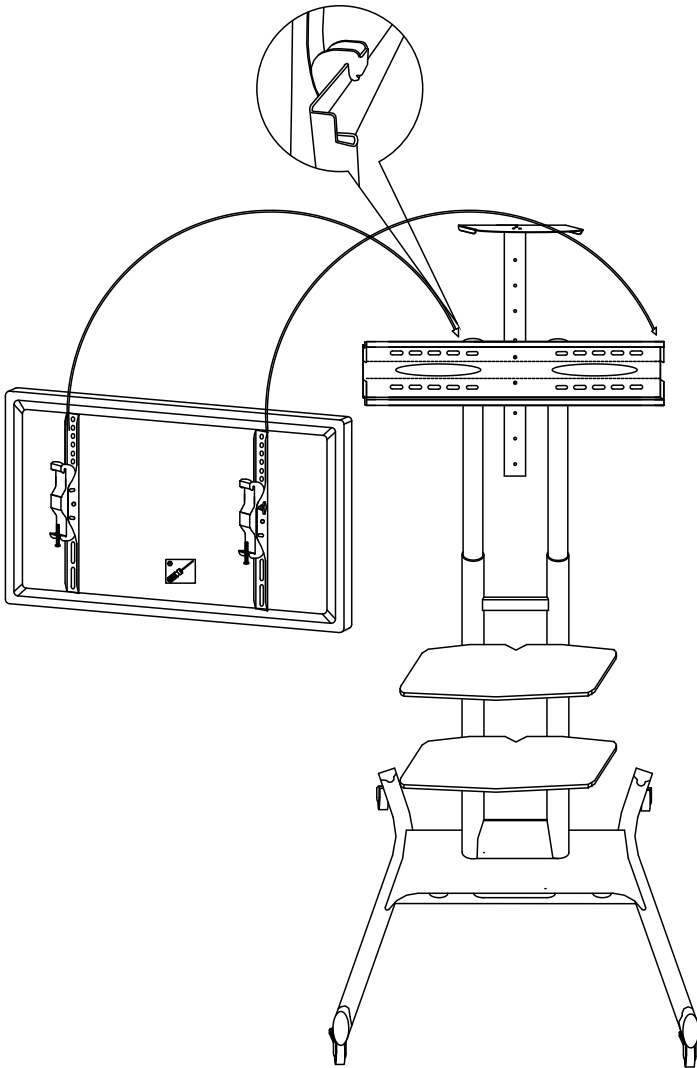

4

**EN** - Note: Move TV to center.  
**DE** - Hinweis: Richten Sie das TV  
Gerät mittig aus.  
**ES** - Nota : Mover la TV al centro.  
**FR** - NB : centrez le téléviseur  
**IT** - Muovere la TV al centro.

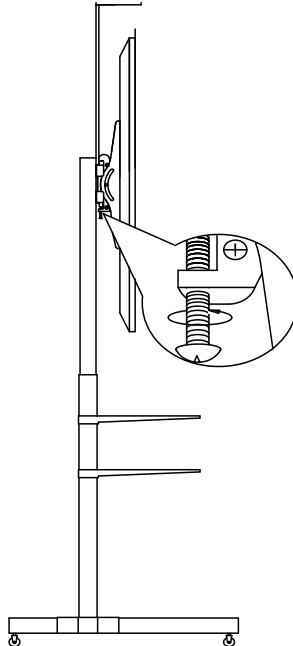
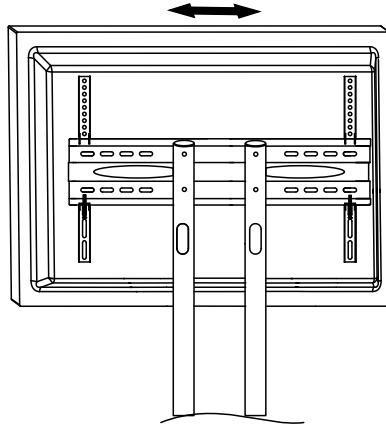



5

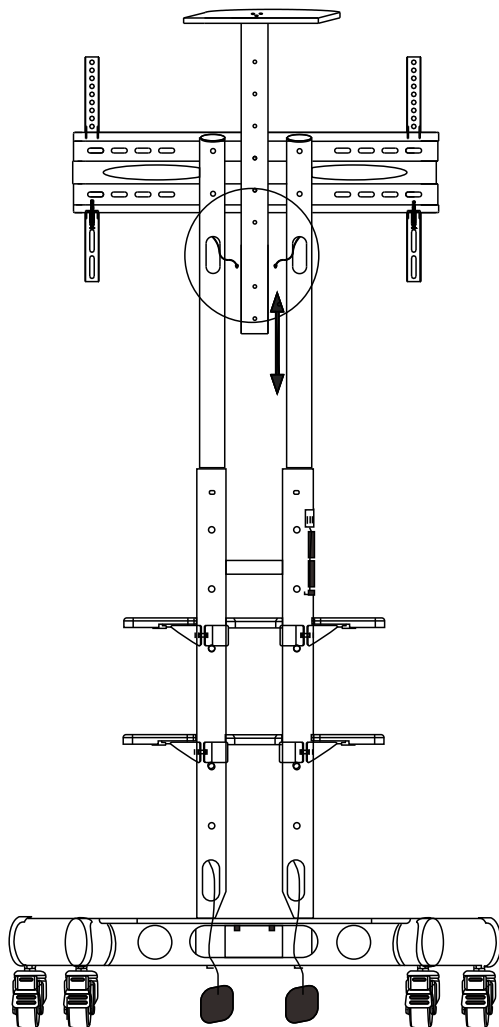

**EN** - Be cautious when routing the wire to avoid damage.

**DE** - Um Beschädigungen zu vermeiden, Bitte VORSICHT beim Verlegen der Kabel.

**ES** - Tenga cuidado al tender el cable para evitar daños.

**FR** - Attention en passant les fils dans le support de ne pas les endommager.

**IT** - Prestare attenzione durante il passaggio del filo.

EN



**Good job.** Would you like to share your experience to assist others with their shopping decisions?



**Not good.** If you are not satisfied with this shopping experience, please contact us via [help@yaheetech.shop](mailto:help@yaheetech.shop).

DE



**Gut.** Wollen Sie Ihre Erfahrungen teilen, um anderen Kunden bei ihrer Kaufentscheidung zu helfen?



**Nicht gut.** Wenn Sie mit diesem Einkaufserlebnis nicht zufrieden sind, kontaktieren Sie unseren Kundenservice per E-Mail: [help@yaheetech.shop](mailto:help@yaheetech.shop) für weitere Hilfe.



Hergestellt in PRC für Yahee GmbH

Importeur: Yahee GmbH

Hans-Grüninger-Weg 11

71706 Markgröningen

Willkommen auf unserer Webseite, Web: [www.yaheetech.de](http://www.yaheetech.de)

ES



**Satisfecho.** ¿Le gustaría compartir su experiencia para ayudar a otros clientes en su compra?



**Insatisfecho.** Si no está satisfecho con su compra, póngase en contacto con nosotros a través de [help@yaheetech.shop](mailto:help@yaheetech.shop).

FR



**Satisfait.** Souhaitez-vous partager votre expérience pour aider d'autres potentiels clients dans leur choix ?



**Mécontent.** Si vous n'êtes pas satisfait de votre achat, contactez-nous via [help@yaheetech.shop](mailto:help@yaheetech.shop).

IT



**Soddisfatto.** Ti piacerebbe condividere la tua esperienza con gli altri utenti?



**Insoddisfatto.** Se non sei soddisfatto della tua esperienza, si prega di contattarci all'indirizzo mail: [help@yaheetech.shop](mailto:help@yaheetech.shop).

EN - You can also get a downloadable user manual by scanning the QR code below.

DE - Sie können auch ein herunterladbares Benutzerhandbuch erhalten, indem Sie den QR-Code unten scannen.

ES - Puede descargar una versión digital escaneando el siguiente código QR.

FR - Vous pouvez télécharger une version digitale en scannant le code QR ci-dessous.

IT - Puoi scaricare il libretto delle istruzioni scannerizzando il codice QR in fondo alla pagina.



610856

[www.yaheeshop.com/  
pdf/all-1-6010885.pdf](http://www.yaheeshop.com/pdf/all-1-6010885.pdf)