

JORGENSEN®

#93709

5PC WOOD CHISEL SET WITH TOOLS BAG
CISEAUX À BOIS 5 PIÈCES AVEC SAC À OUTILS
5-TLG. STECHBEITEL SET MIT TASCHE
5-PIEZAS CINCELES PARA MADERA CON BOLSA
SCALPELLI PER LEGNO DA 5 PEZZI CON BORSA DEGLI ATTREZZI

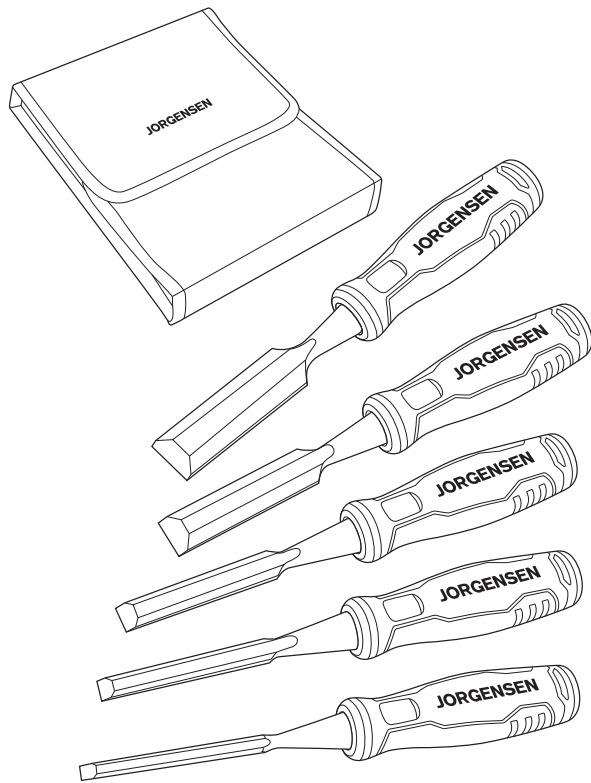

PONY | JORGENSEN

Saddle Brook, NJ 07663 USA

ponyjorgensen.com   

Made in China | Fabriqué en Chine | Hergestellt in China

Fabricado en China | Prodotto in Cina

Rev 01/2024

EN

⚠ WARNING

Wear safety goggles. Blades are extremely sharp. Handle with care. Sharp chisels are dangerous and should be handled with care. Dull chisels are even more dangerous and should be sharpened.



INCLUDED

- (1) 1/4" (6mm) wood chisel
- (1) 3/8" (10mm) wood chisel
- (1) 1/2" (12mm) wood chisel
- (1) 3/4" (19mm) wood chisel
- (1) 1" (25mm) wood chisel
- (1) Tools bag

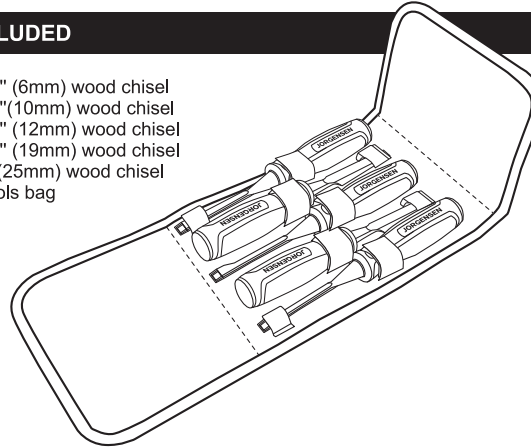

SPECIFICATIONS

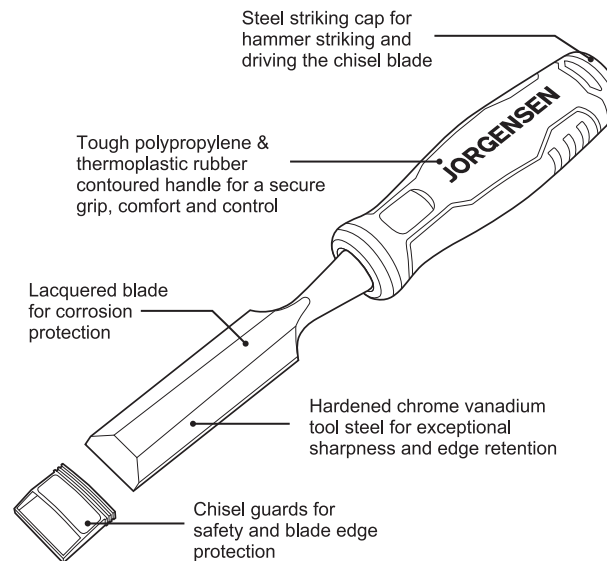

MAINTENANCE

To protect your chisel from rust, be sure to oil, wax and/or wrap the tools after use.

FR

⚠ AVERTISSEMENT

Portez des lunettes de protection. Les lames sont extrêmement tranchantes. Manipulez-les avec précaution. Les ciseaux tranchants sont dangereux et doivent être manipulés avec précaution. Les ciseaux émoussés sont encore plus dangereux et doivent être aiguisés.



INCLUS

- (1) Ciseau à bois de 1/4" (6mm)
- (1) Ciseau à bois de 3/8" (10mm)
- (1) Ciseau à bois de 1/2" (12mm)
- (1) Ciseau à bois de 3/4" (19mm)
- (1) Ciseau à bois de 1" (25mm)
- (1) Sac à outils

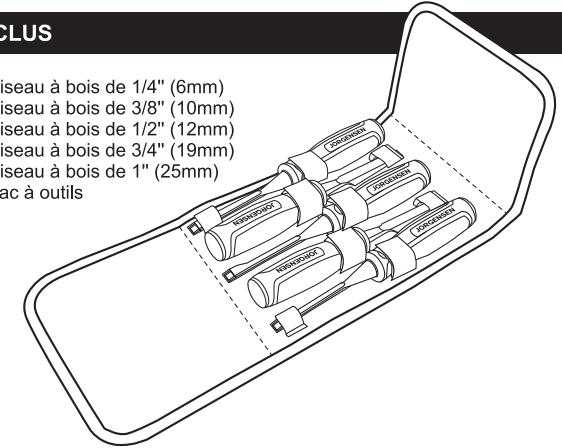

SPÉCIFICATIONS

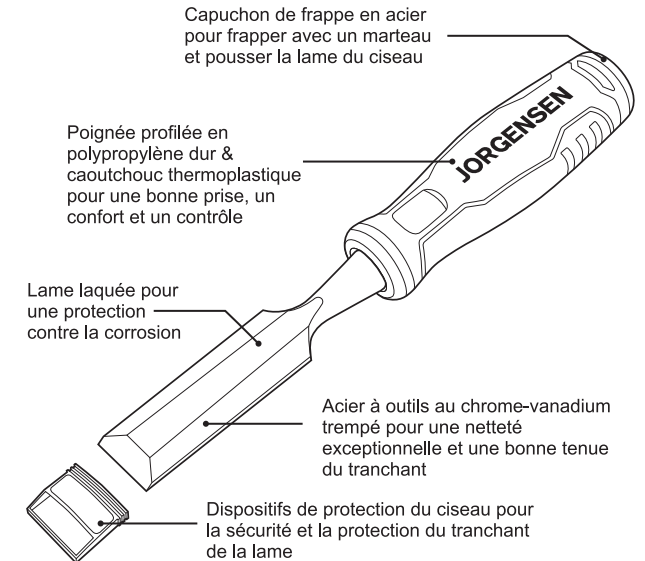

ENTRETIEN

Pour protéger votre ciseau contre la rouille, assurez-vous d'huiler, de cirer et/ou d'envelopper les outils après l'utilisation.

⚠️ WARNUNG

Tragen Sie eine Schutzbrille. Die Klingen sind extrem scharf. Vorsicht im Umgang. Scharfe Meißel sind gefährlich und sollten mit Vorsicht behandelt werden. Stumpfe Meißel sind noch gefährlicher und sollten geschliffen werden.

**INKLUSIVE**

- (1) 1/4" (6mm) Holzmeißel
- (1) 3/8" (10mm) Holzmeißel
- (1) 1/2" (12mm) Holzmeißel
- (1) 3/4" (19mm) Holzmeißel
- (1) 1" (25mm) Holzmeißel
- (1) Werkzeugtasche

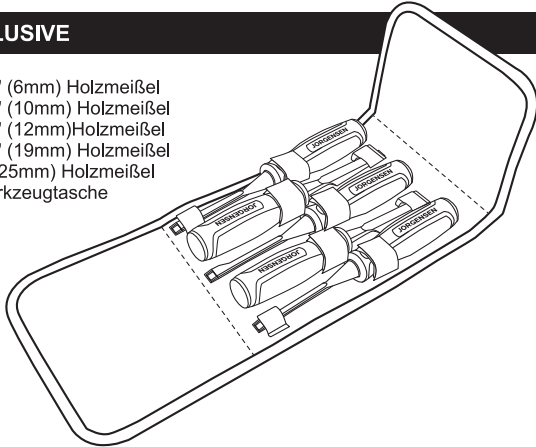
**TECHNISCHE DATEN**

Schlagkappe aus Stahl für Hammerschläge und zum Antreiben der Meißelklinge

Robuster Griff aus Polypropylen und thermoplastischem Gummi für sicheren Halt, Komfort und Kontrolle

Lackierte Klinge zum Schutz vor Korrosion

Gehärteter Chrom-Vanadium-Werkzeugstahl für außergewöhnliche Schärfe und Schnitthaltigkeit

Meißelschutz für Sicherheit und Klingenkantenschutz

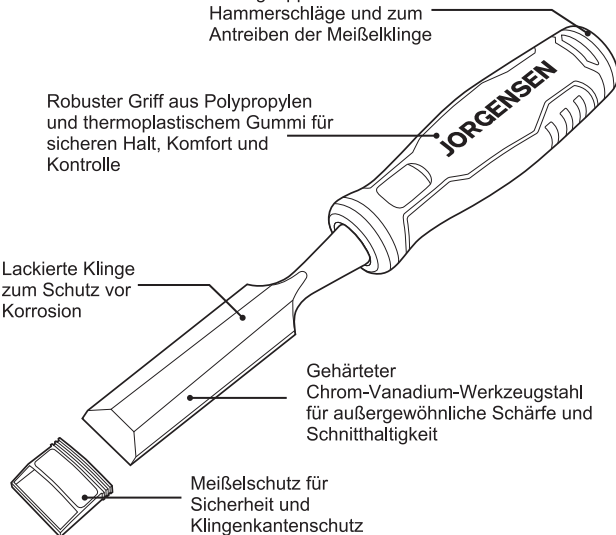
**WARTUNG**

Um Ihr Stemmeisen vor Rost zu schützen, sollten Sie es nach Gebrauch einölen, wachsen und/oder einpacken.

⚠️ ADVERTENCIA

Lleve gafas protectoras. Las hojas están muy afiladas. Úselas con cuidado. Los cinceles afilados son peligrosos y deben usarse con cuidado. Los cinceles desafilados son aún más peligrosos y deben afilarse.

**INCLUIDO**

- (1) Cincel de madera de 1/4" (6mm)
- (1) Cincel de madera de 3/8" (10mm)
- (1) Cincel de madera de 1/2" (12mm)
- (1) Cincel de madera de 3/4" (19mm)
- (1) Cincel de madera de 1" (25mm)
- (1) Bolsa de herramientas

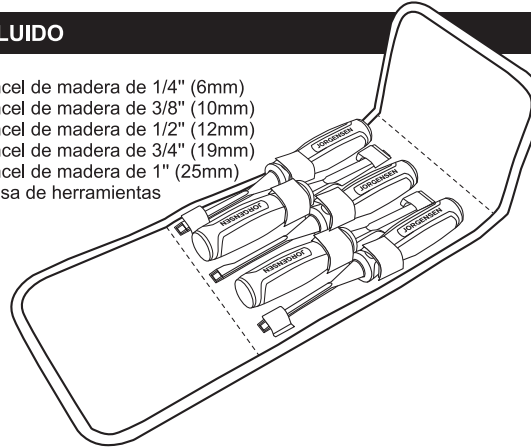
**ESPECIFICACIONES**

Caperuza de acero para golpear con el martillo e impulsar la hoja del cincel

Mango contorneado de polipropileno resistente y caucho termoplástico para un agarre seguro, comodidad y control

Hoja lacada para protección contra la corrosión

Acero al cromo vanadio endurecido para herramientas con un afilado y una retención del filo superiores

Protectores de cincel para la seguridad y protección de la hoja

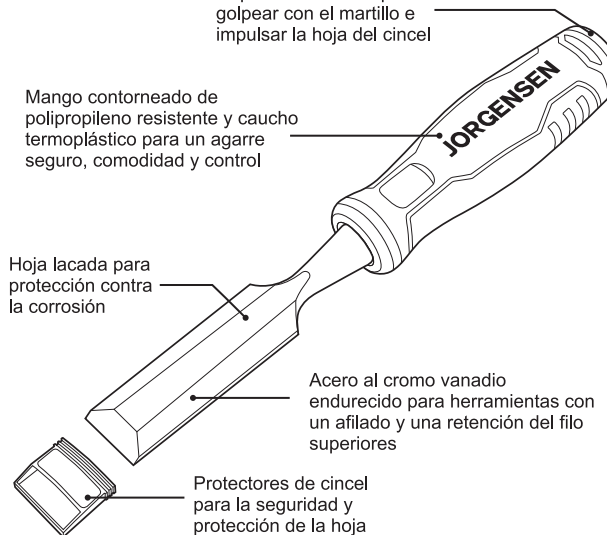
**MANTENIMIENTO**

Para evitar que los cinceles se oxiden, engrase, encere y/o envuelva siempre las herramientas después de usarlas.

⚠️ AVVERTENZA

Indossare occhiali di sicurezza. Le lame sono estremamente affilate. Maneggiare con cura. Gli scalpelli affilati sono pericolosi e devono essere maneggiati con cura. Gli scalpelli opachi sono ancora più pericolosi e devono essere affilati.

**INCLUSI**

- (1) 1/4" (6mm) scalpello per legno
- (1) 3/8" (10mm) scalpello per legno
- (1) 1/2" (12mm) scalpello per legno
- (1) 3/4" (19mm) scalpello per legno
- (1) 1" (25mm) scalpello per legno
- (1) Borsa per attrezzi

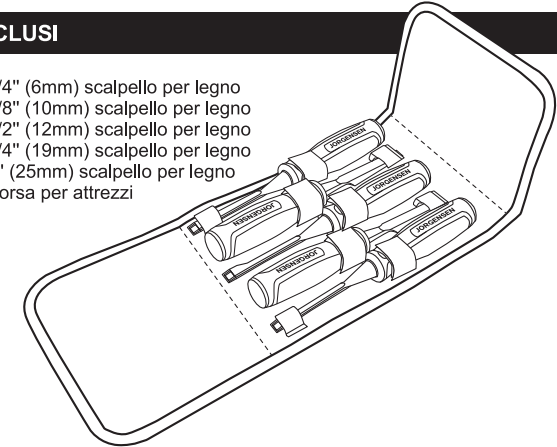
**SPECIFICHE**

Copriforo in acciaio per colpire con il martello e guidare la lama dello scalpello

Impugnatura sagomata in polipropilene e gomma termoplastica per una presa sicura, comfort e controllo

Lama laccata per proteggere dalla corrosione

Acciaio da utensili al cromo vanadio temprato per un'eccezionale affilatura e tenuta del taglio

Copertura protettiva dello scalpello per la sicurezza e la protezione del taglio della lama

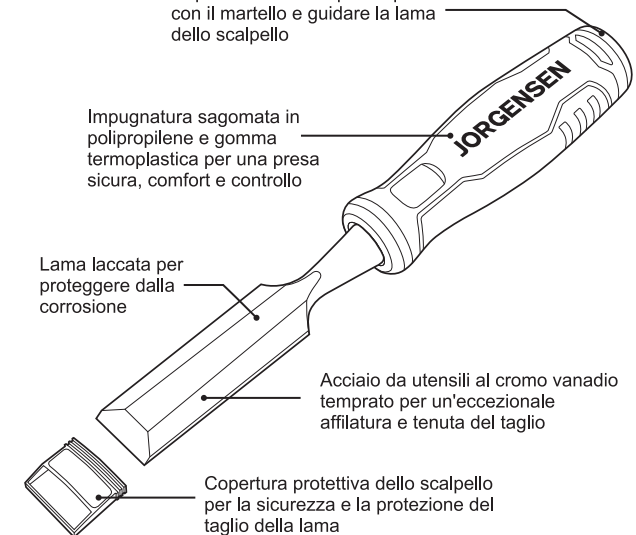
**MANUTENZIONE**

Per proteggere gli scalpelli dalla ruggine, assicurarsi di oliarli, incerarli e/o avvolgerli dopo l'uso.