

Manuel d'instructions/Instruction Manual/
Bedienungsanleitung/Manual de instrucciones/
Manuale di istruzioni/Handleiding

GREGOR

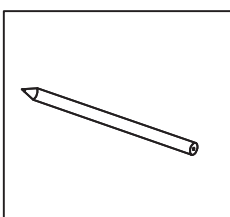
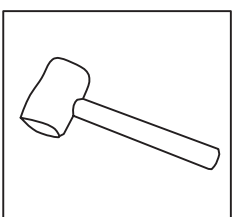
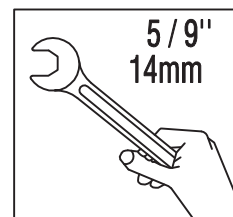
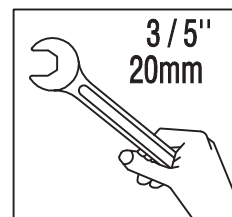
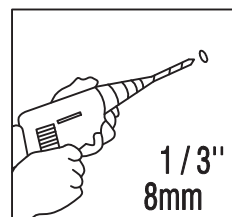
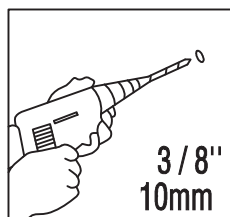
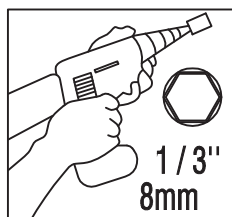
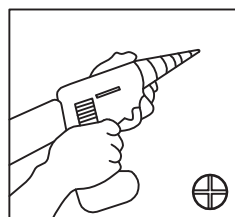
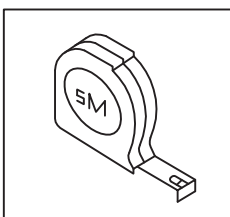
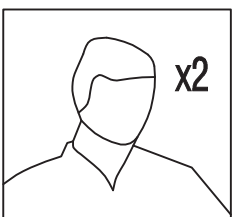
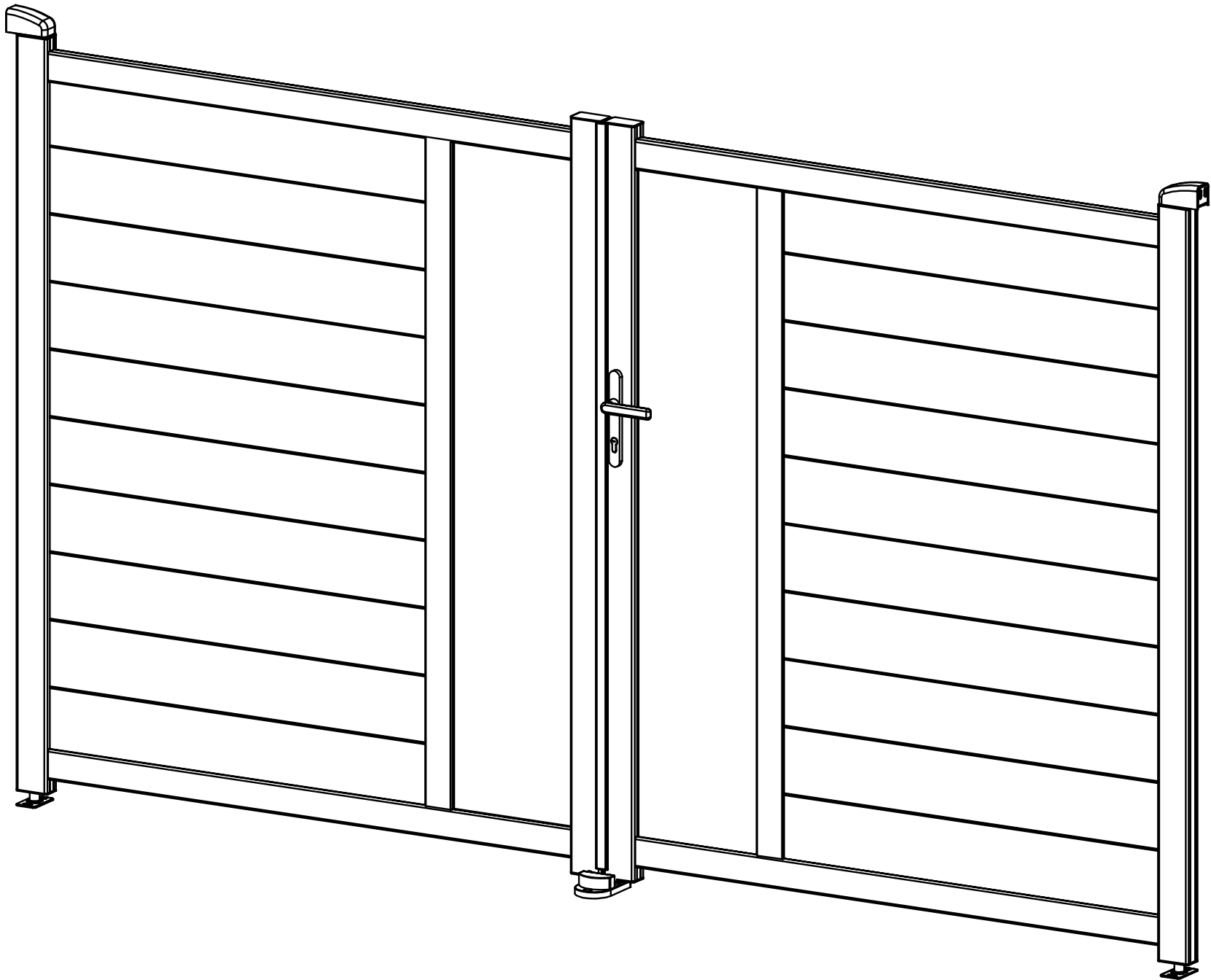

Porte en aluminium Art
B-B + raindrop C2

! AVERTISSEMENT: nécessite un entretien rapide pour s'assurer que la construction est solide.

! WARNING: Need timely maintenance to make sure construction is strong.

! WARNUNG: Sie müssen rechtzeitig gewartet werden, um sicherzustellen, dass die Konstruktion stark ist.

! ADVERTENCIA: Necesita un mantenimiento oportuno para asegurarse de que la construcción sea sólida.

! AVVERTENZA: è necessaria una manutenzione tempestiva per assicurarsi che la costruzione sia robusta.

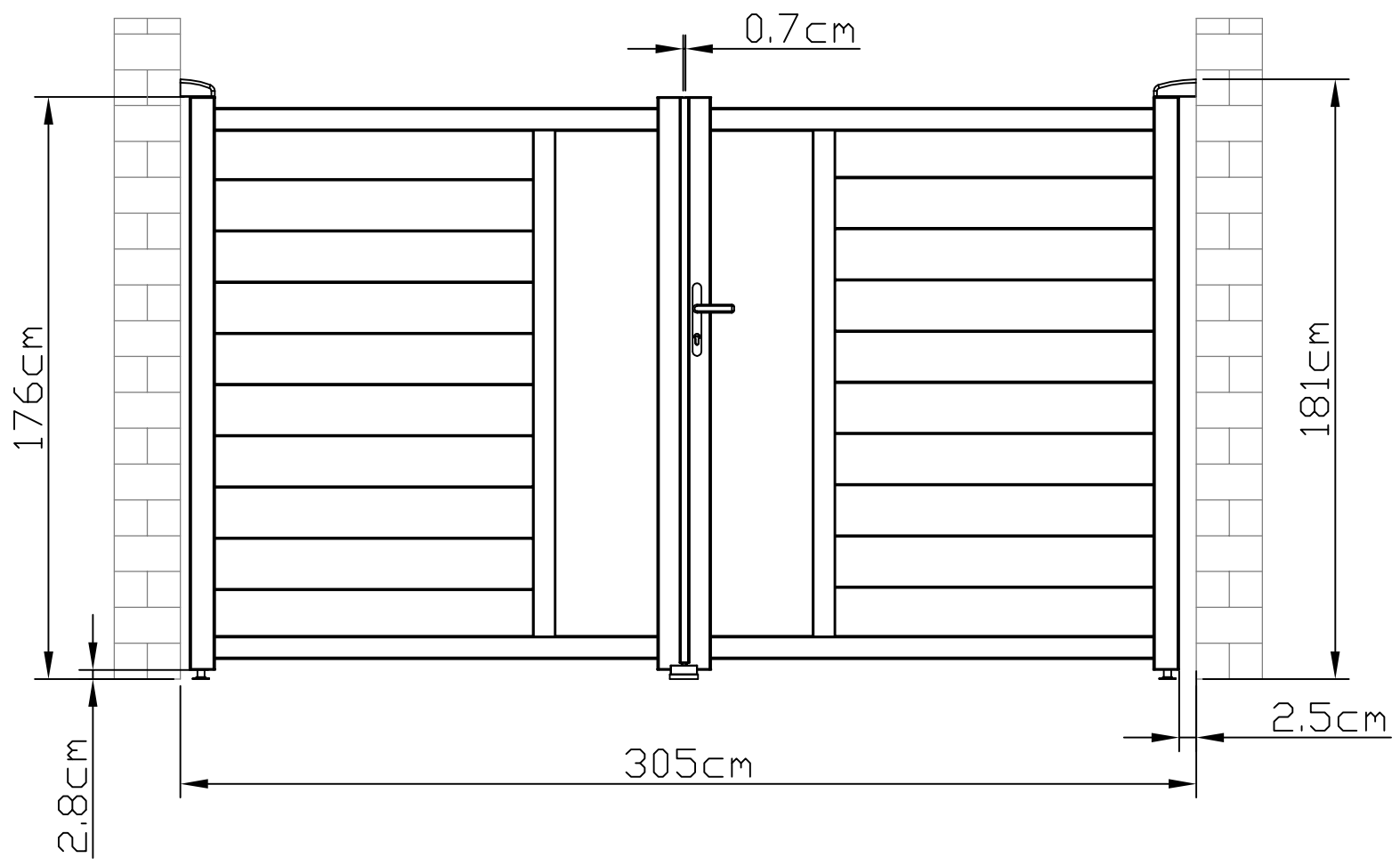

! WAARSCHUWING: Heeft tijdig onderhoud nodig om ervoor te zorgen dat de constructie sterk is.

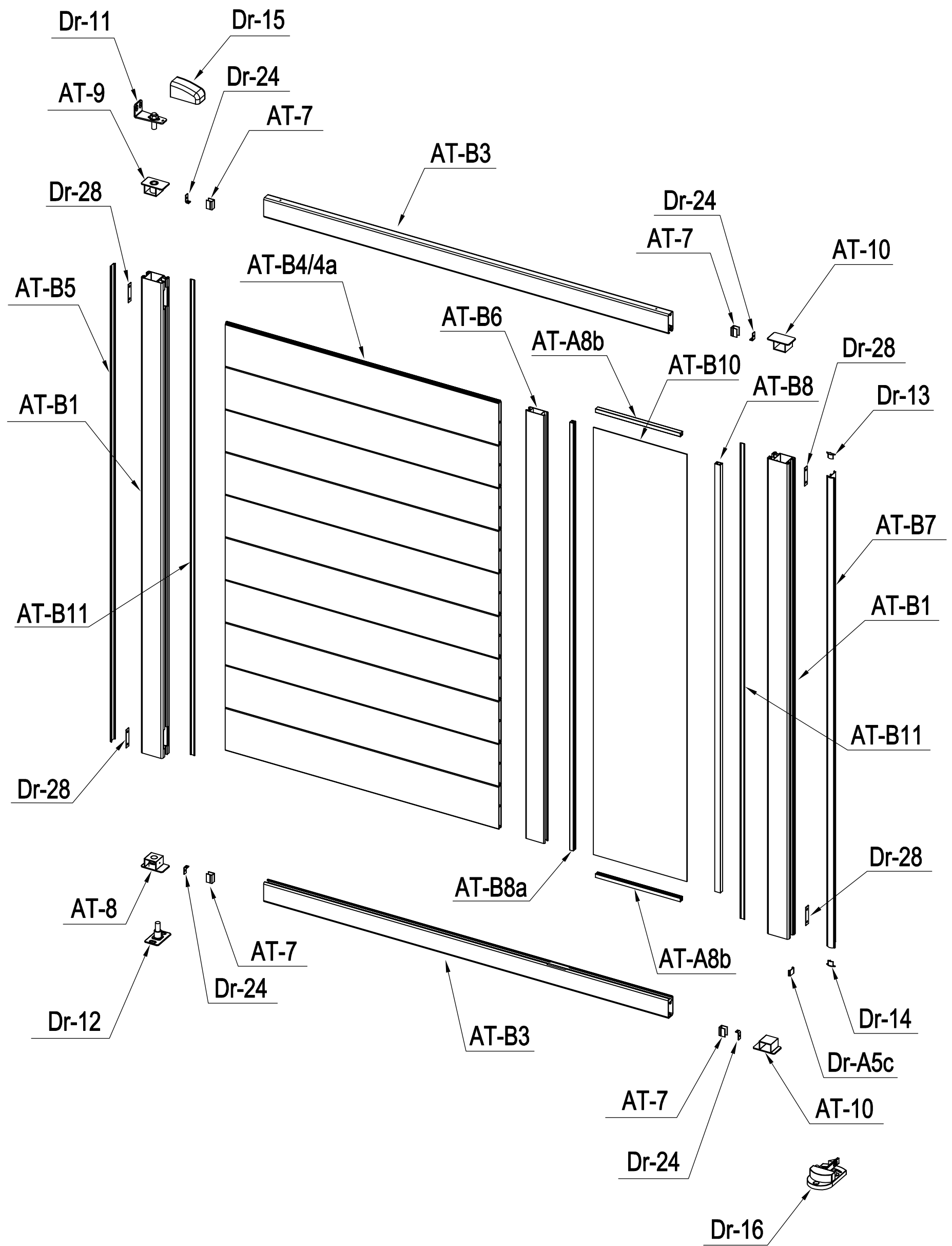

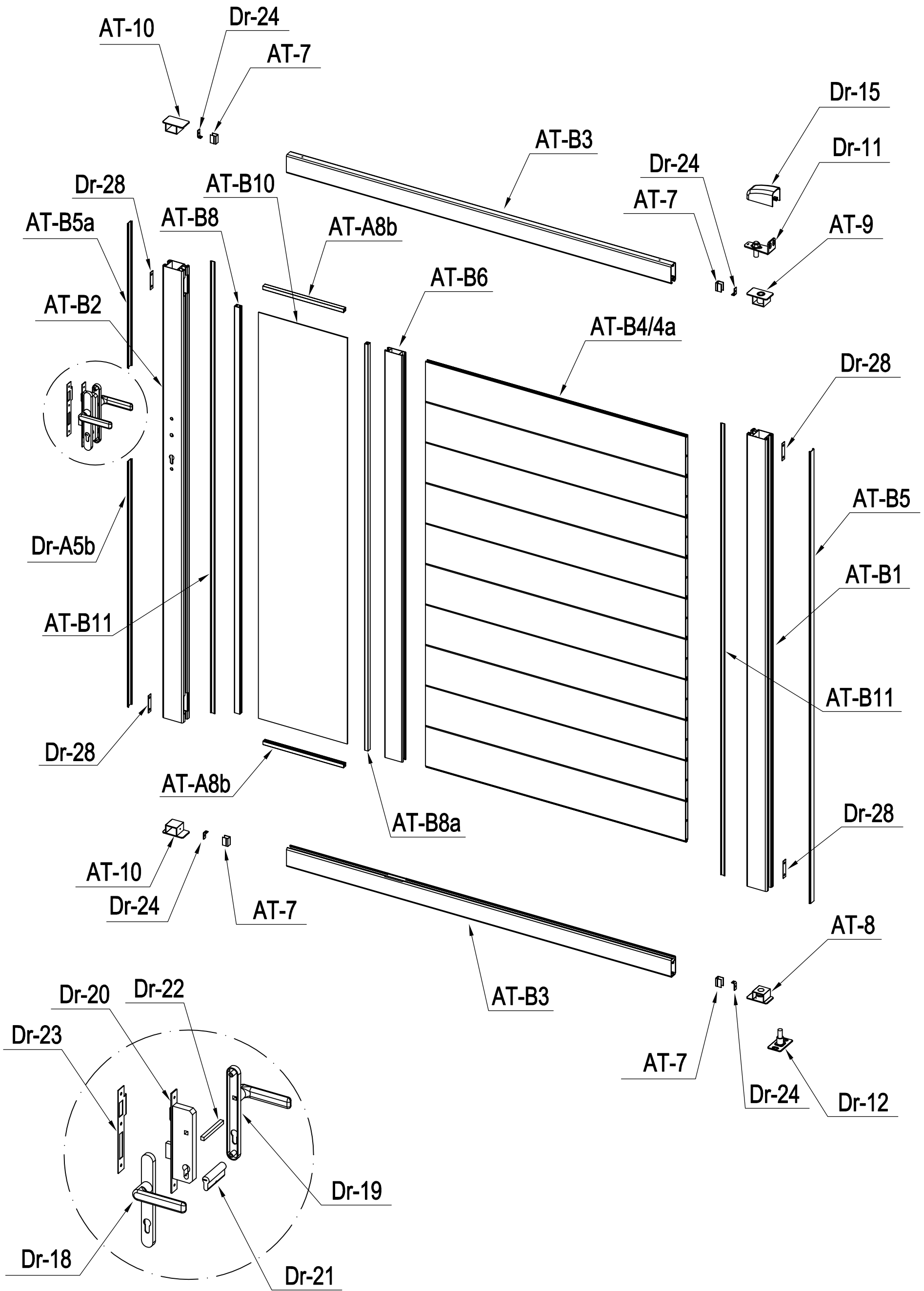

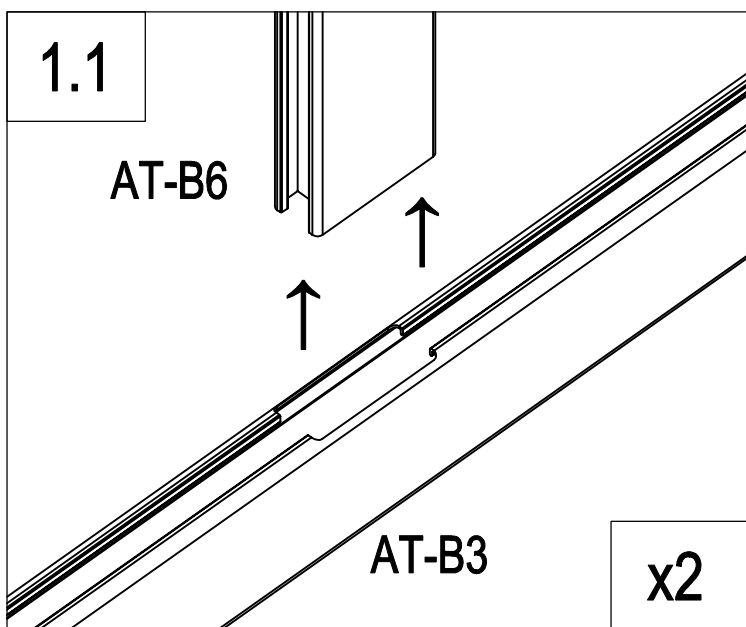
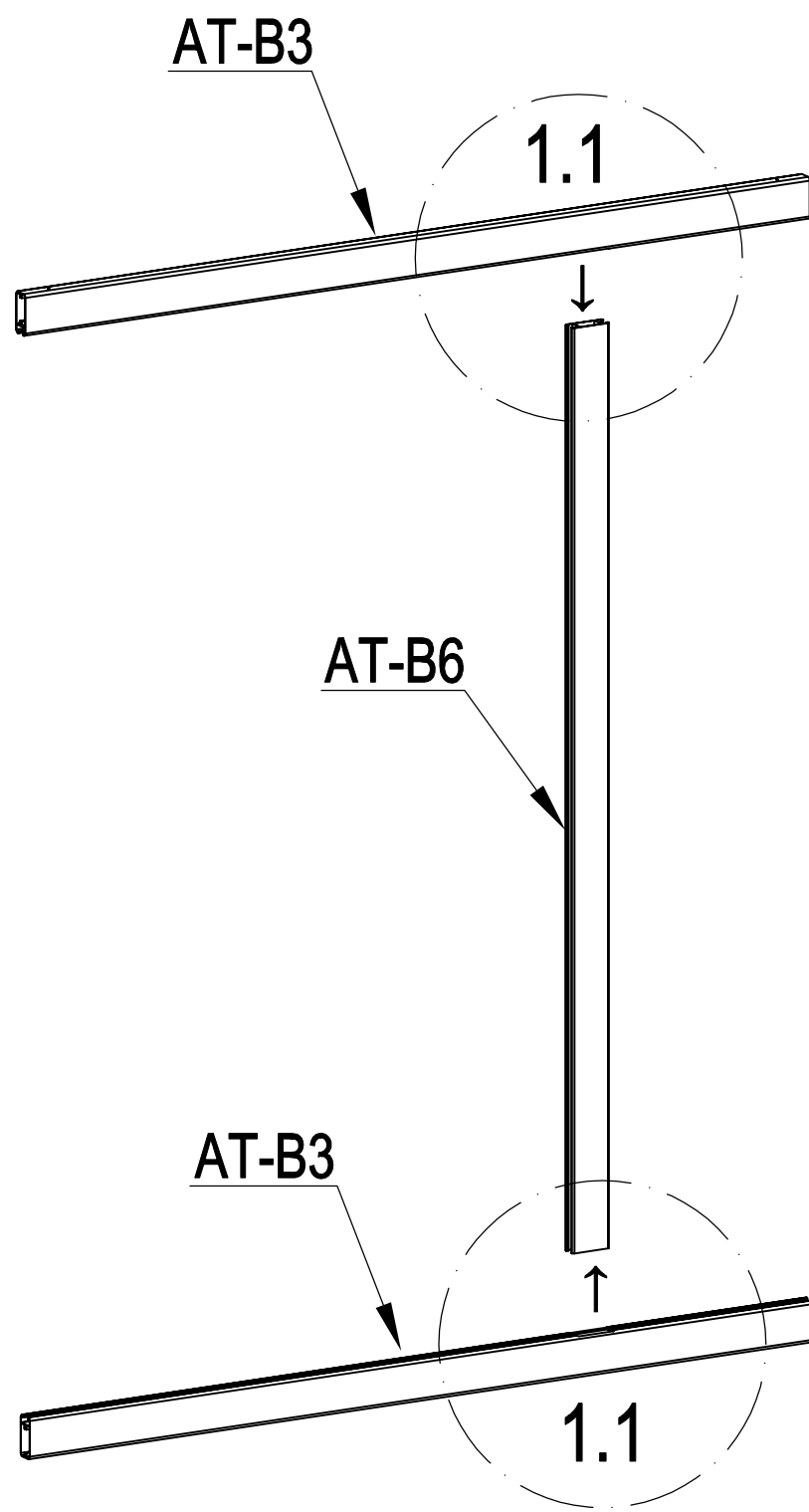



	AT-B6	1
	AT-B3	2

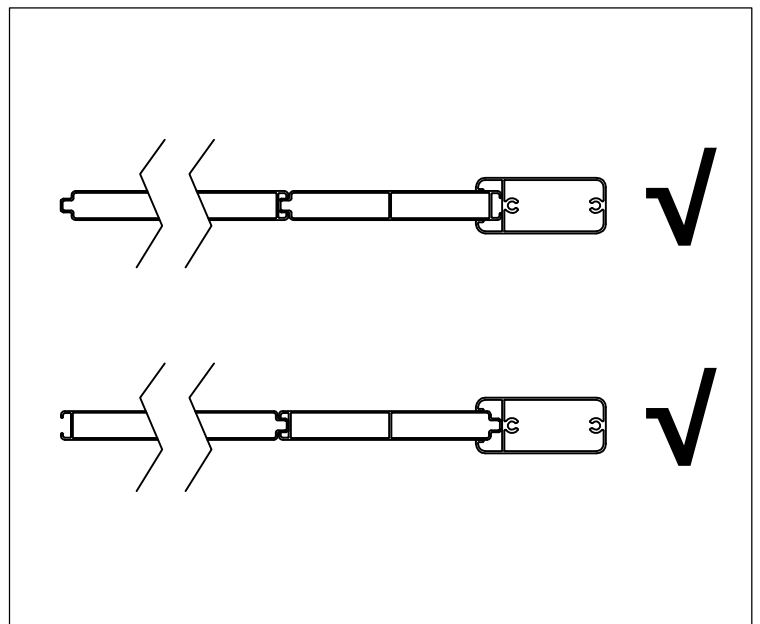
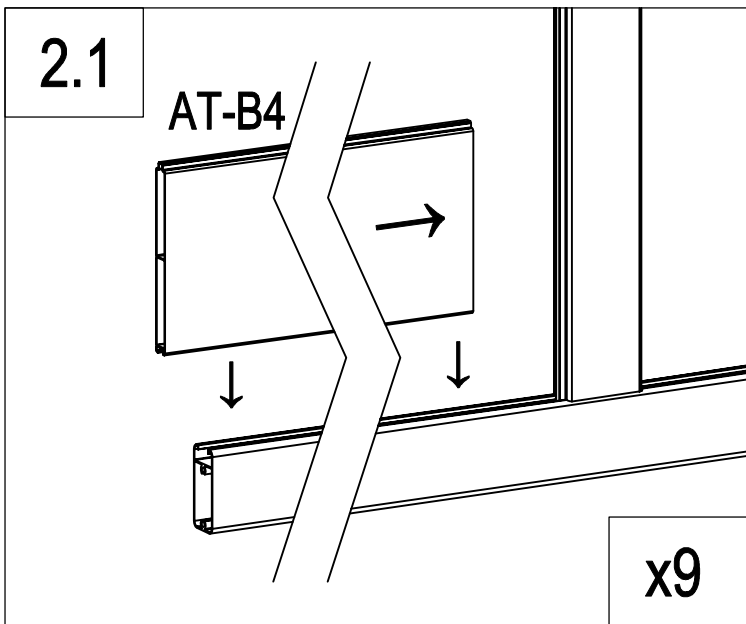
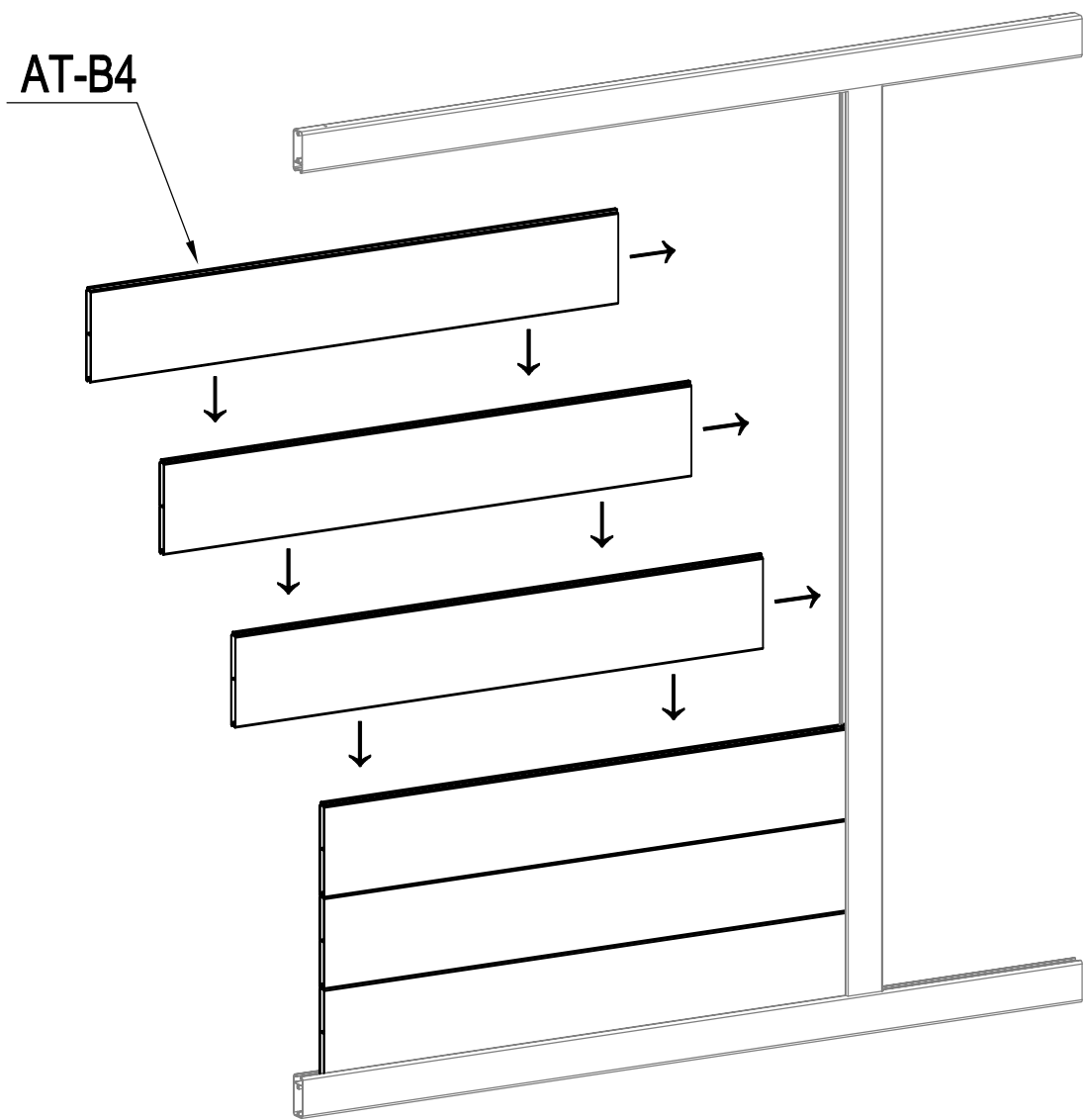

	AT-B4	9
---	-------	---

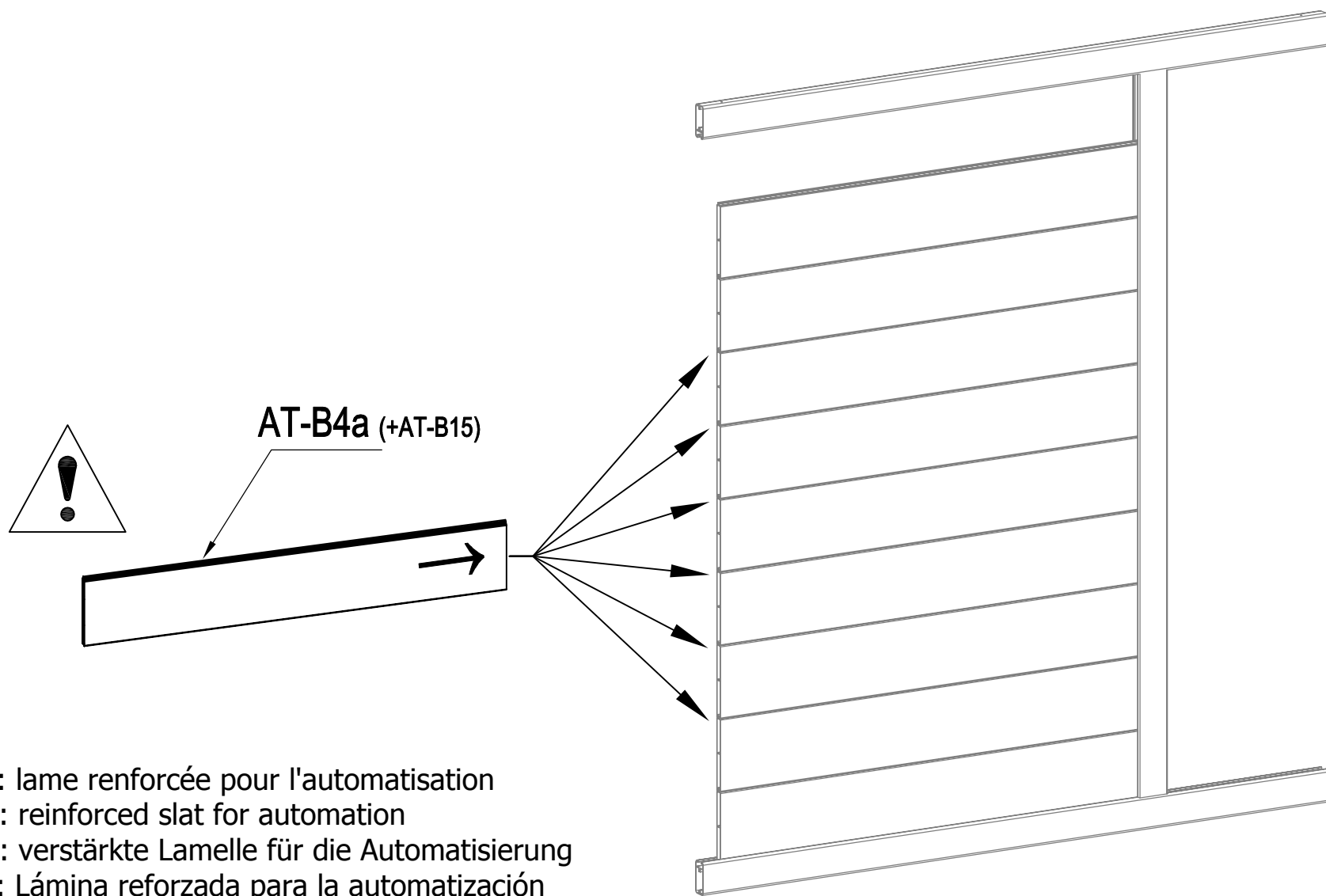

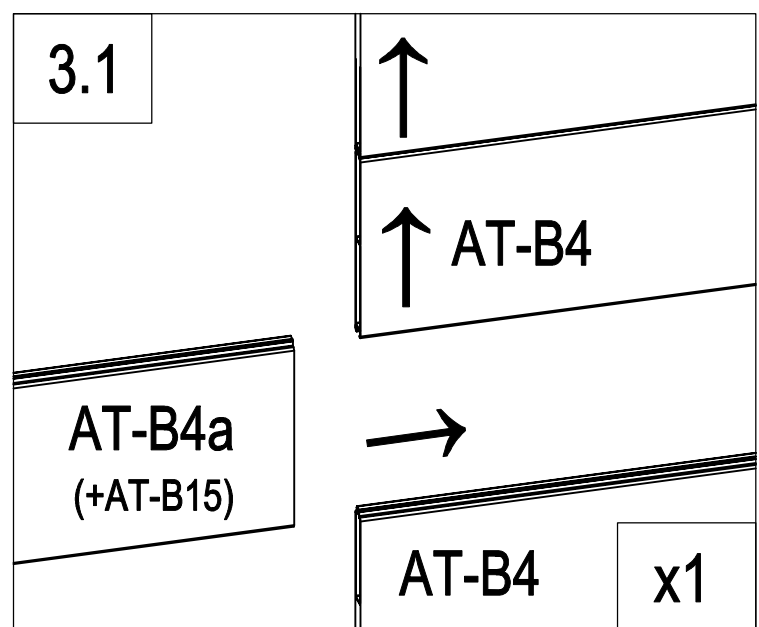
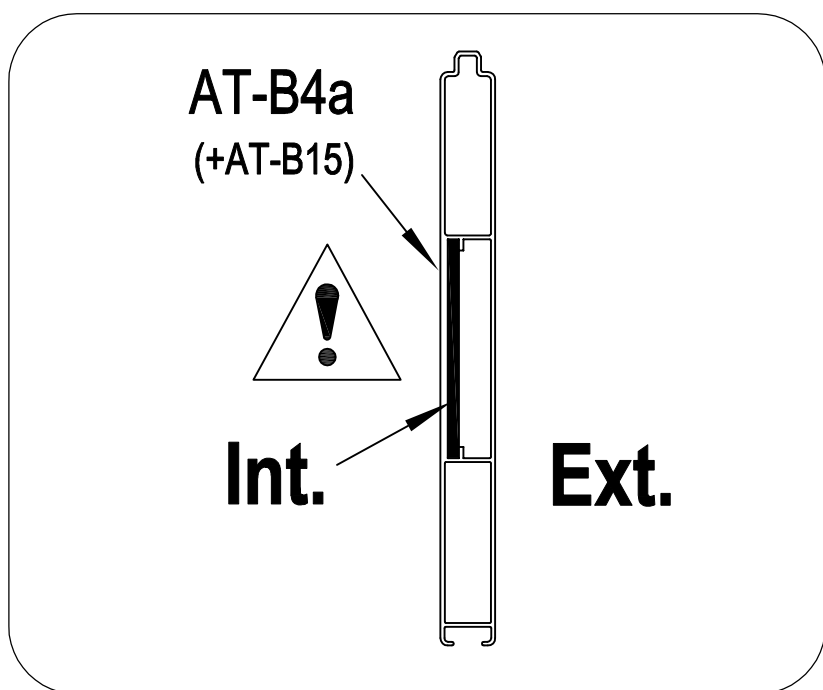

FR: lame renforcée pour l'automatisation
 EN: reinforced slat for automation
 DE: verstärkte Lamelle für die Automatisierung
 ES: Lámina reforzada para la automatización
 IT: lamella rinforzata per l'automazione
 NL: versterkte lat voor automatisering

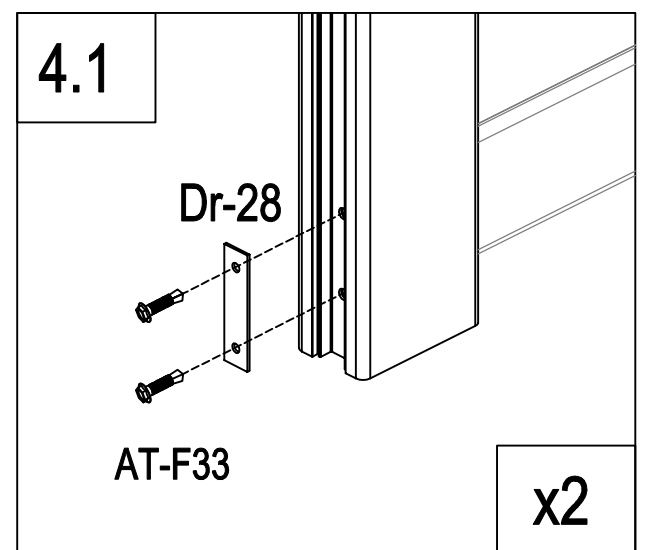
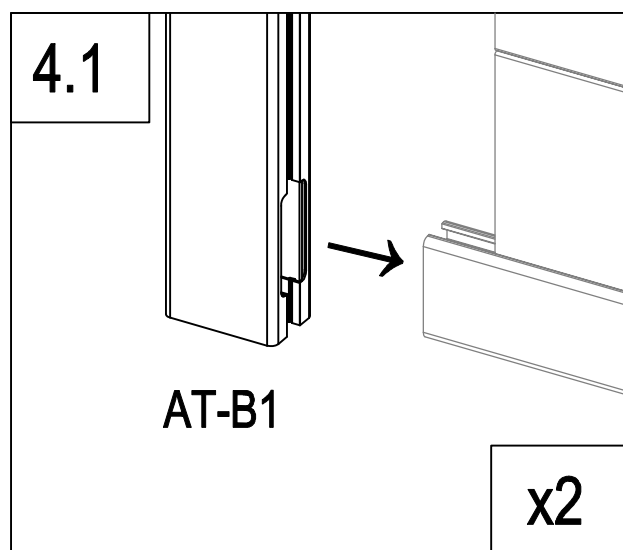
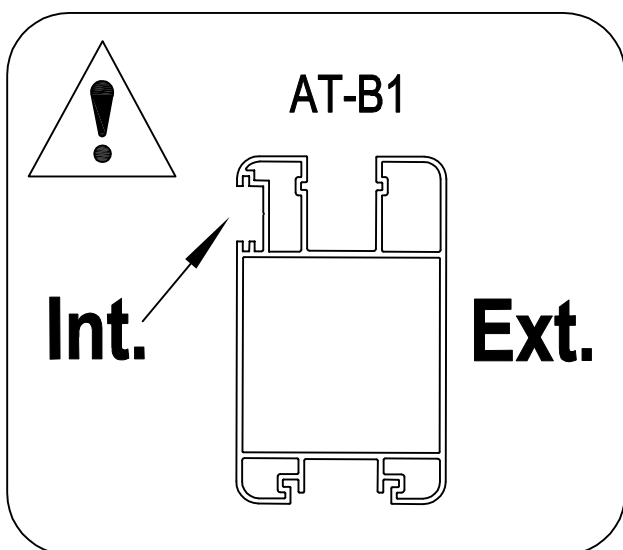
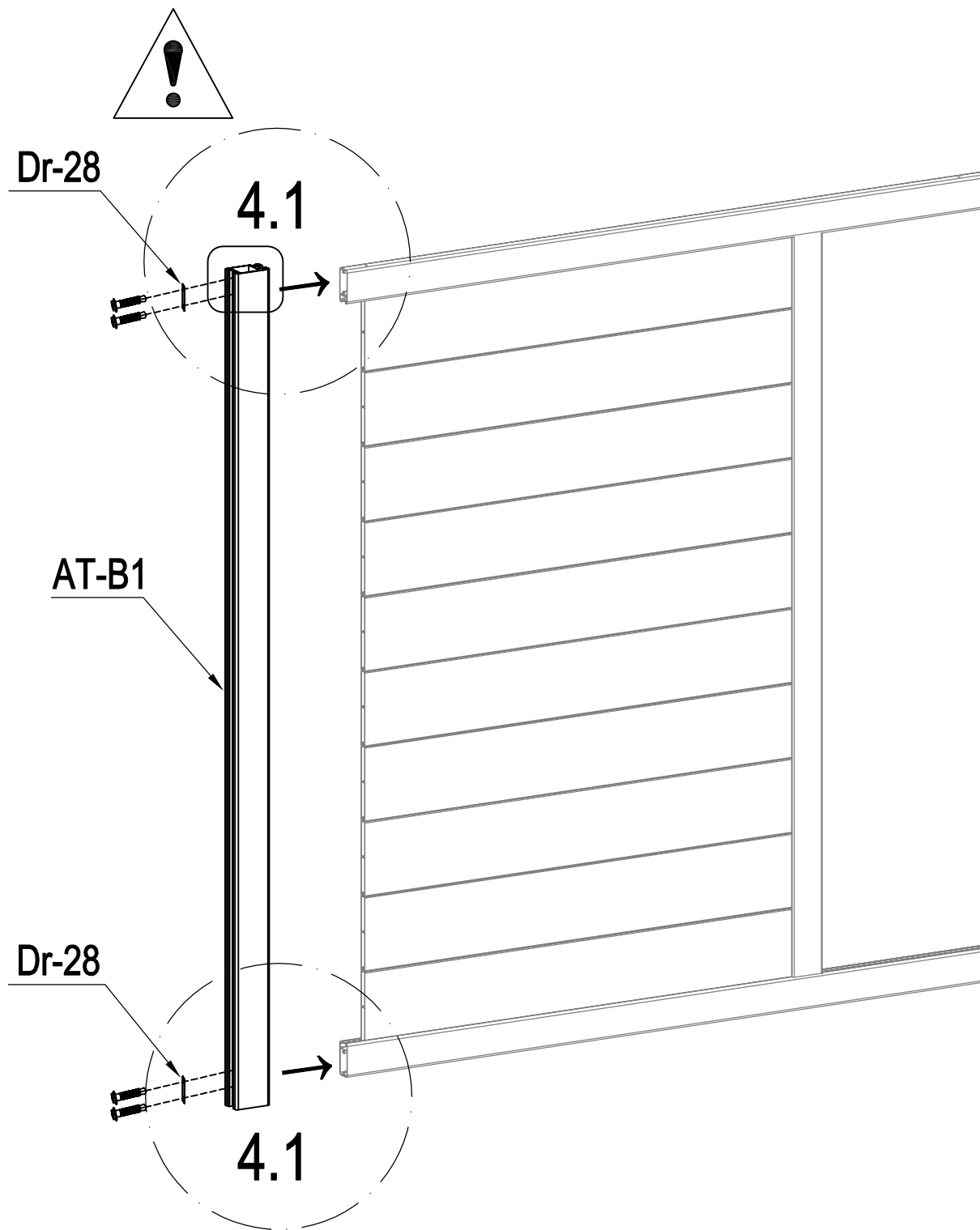

	AT-B4a (+AT-B15)	1
--	------------------	---

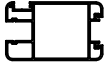

	AT-B1	1
	Dr-28	2
	AT-F33	4

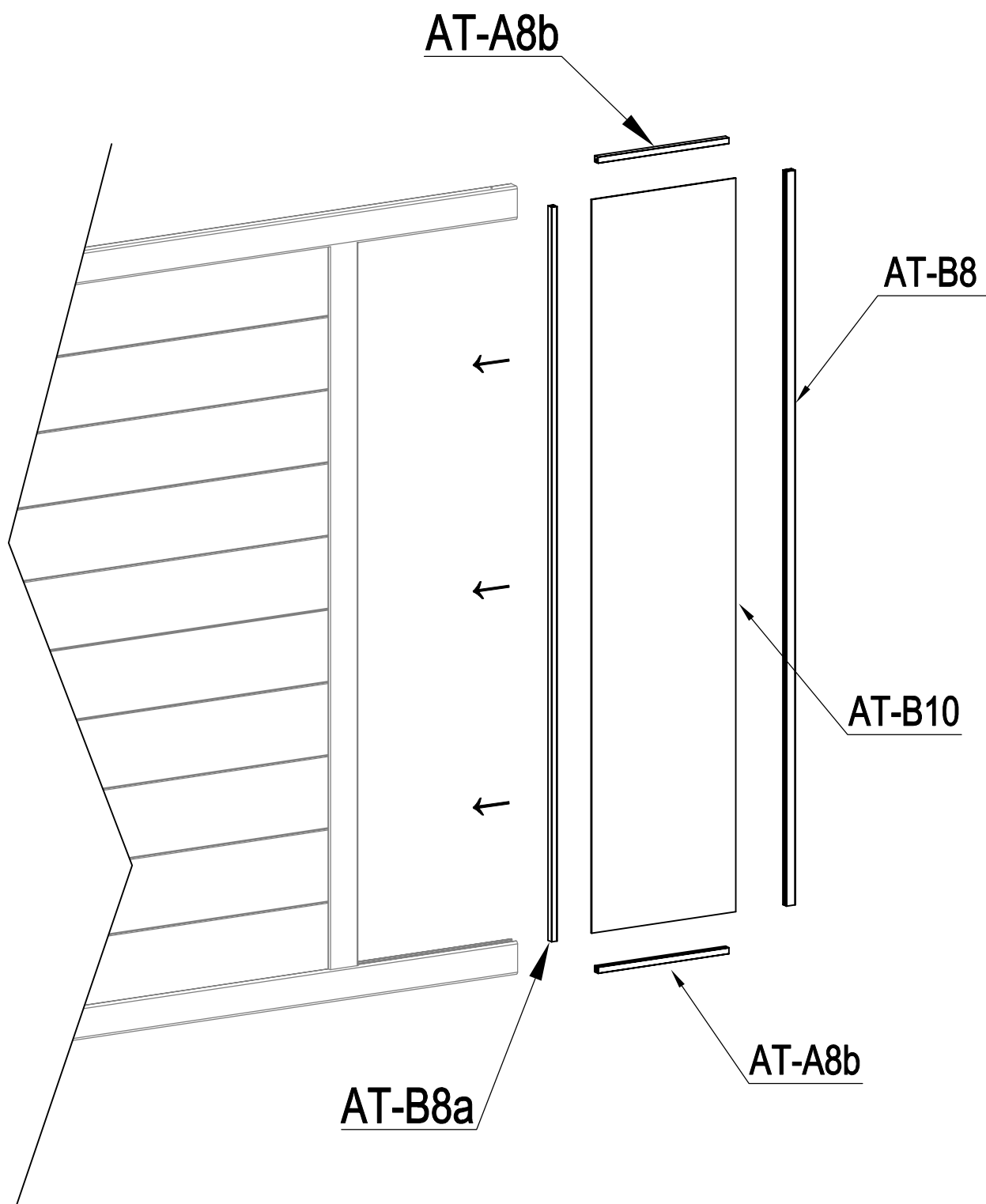

FR: vous pouvez retourner et changer la direction de cette plaque pour personnaliser votre portail

EN :you can flip and switch the direction of this plate to personalize your gate



DE: Sie können dieses Schild umdrehen und die Richtung wechseln, um Ihr Tor zu personalisieren.

ES: puedes girar y cambiar la dirección de esta placa para personalizar tu puerta

IT: potete capovolgere e cambiare la direzione di questa piastra per personalizzare il vostro cancello

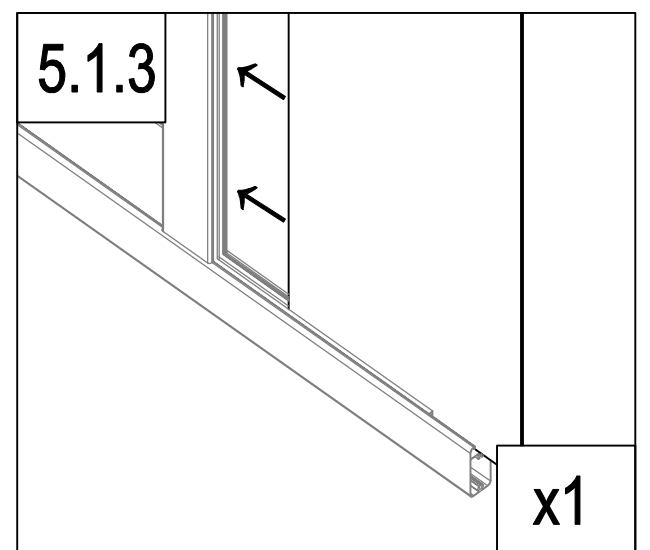
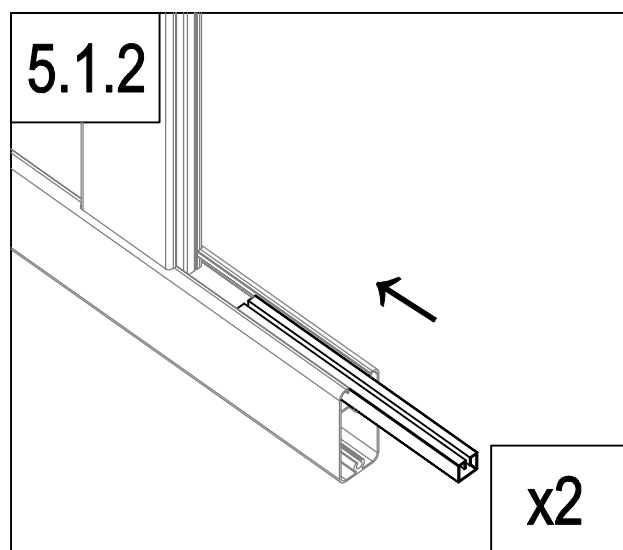
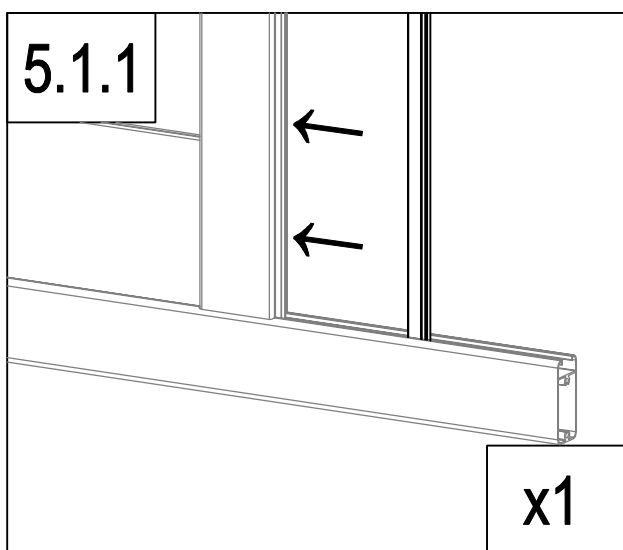

NL: u kunt de richting van deze plaat omdraaien en veranderen om uw poort te verpersoonlijken...

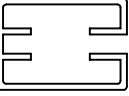

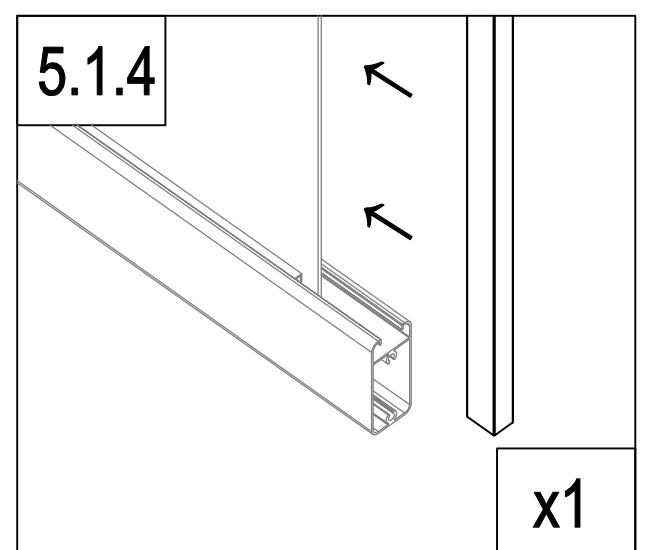
	AT-B8a	1
	AT-A8b	2
	AT-B10	1
	AT-B8	1

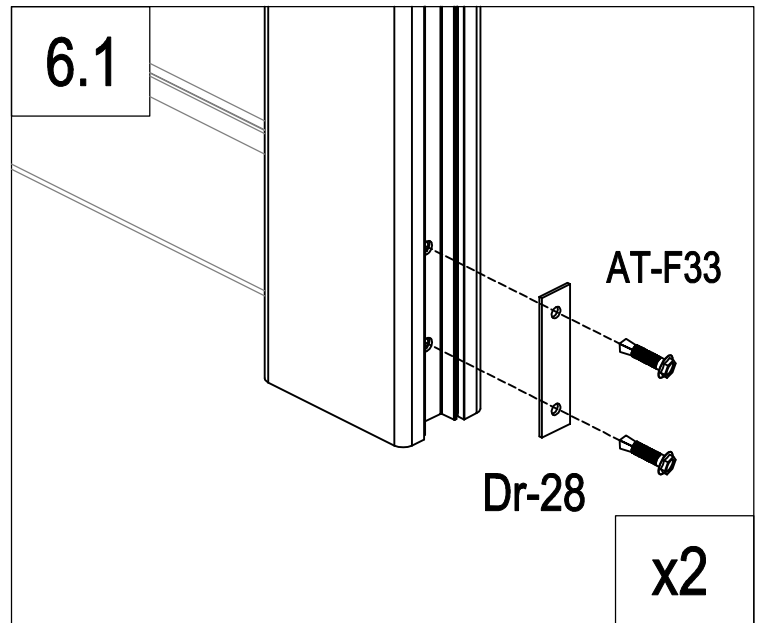
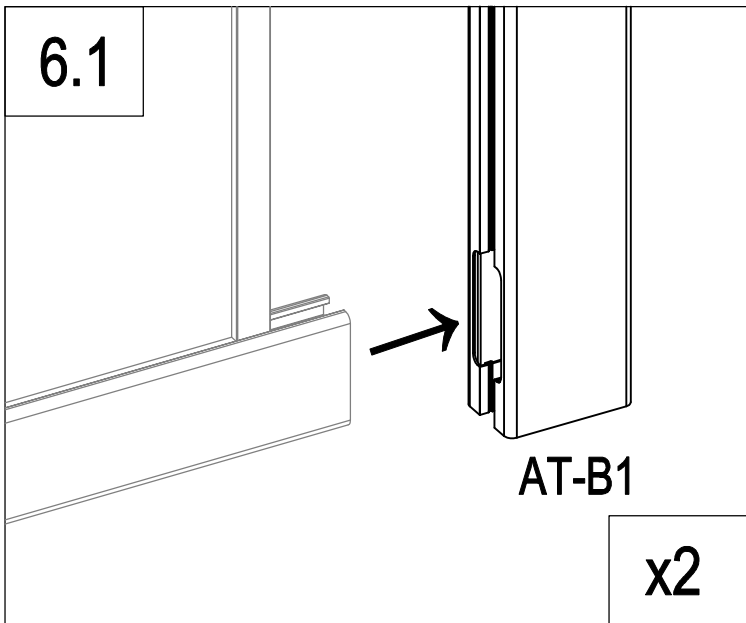
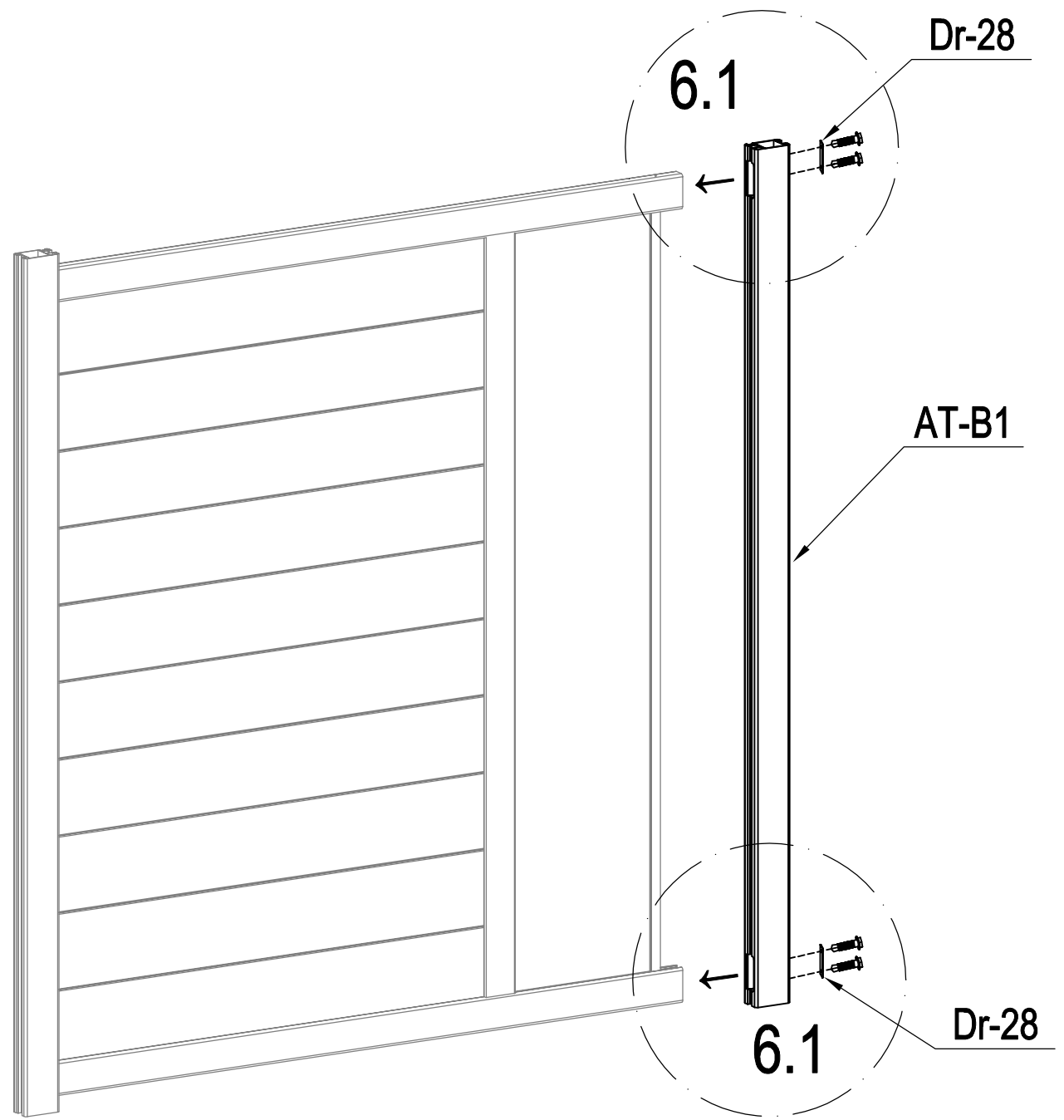

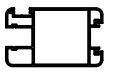

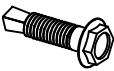
	AT-B1	1
	Dr-28	2
	AT-F33	4

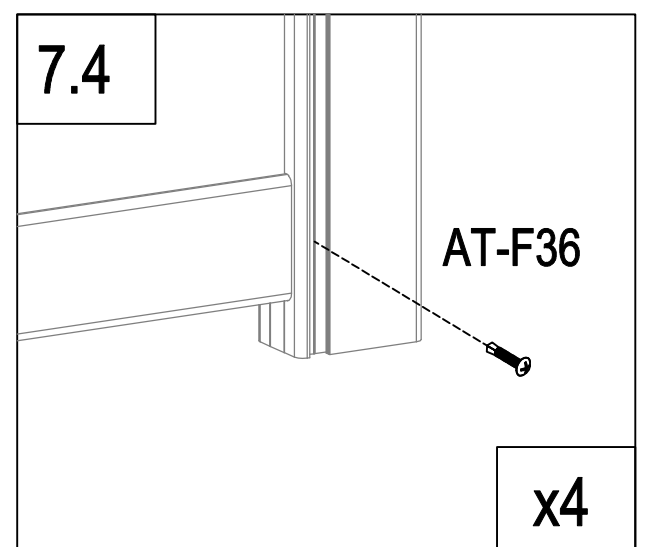
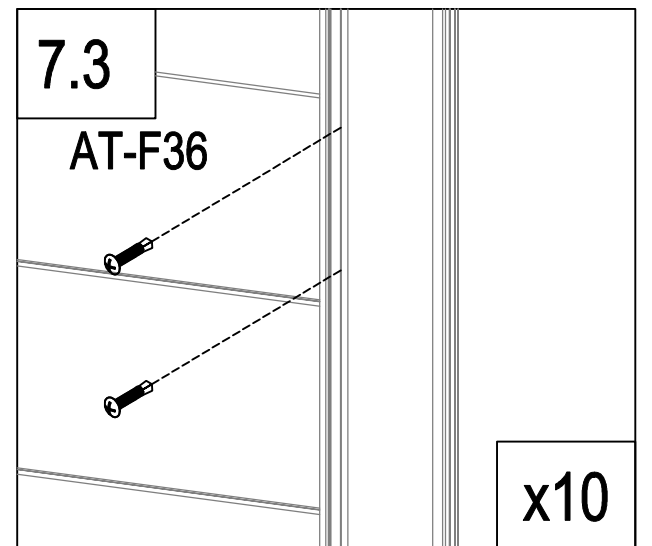
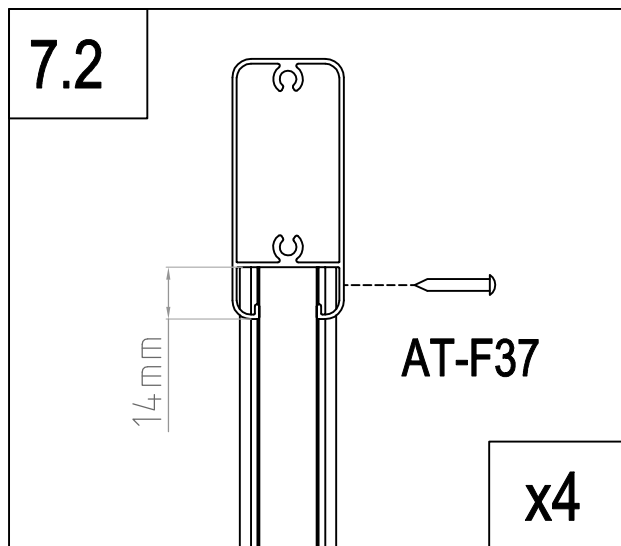
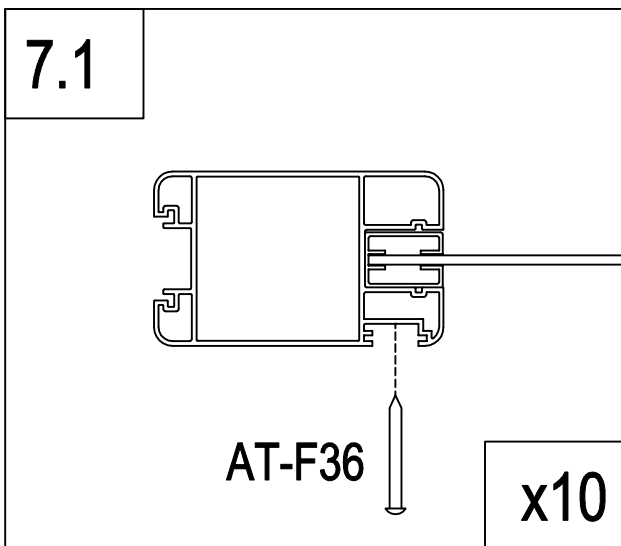
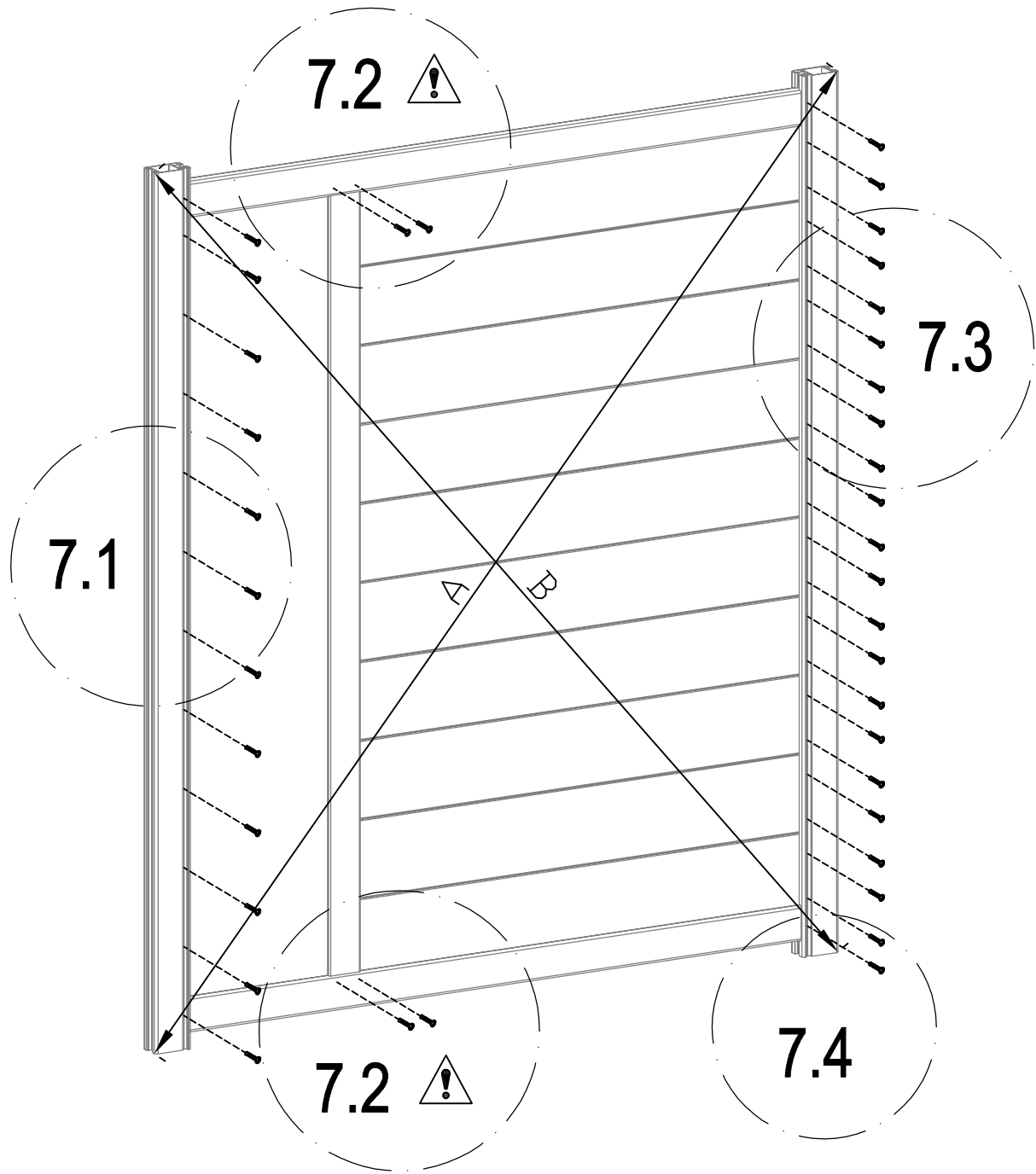
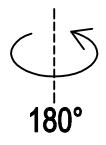

	AT-F36	34
	AT-F37	4

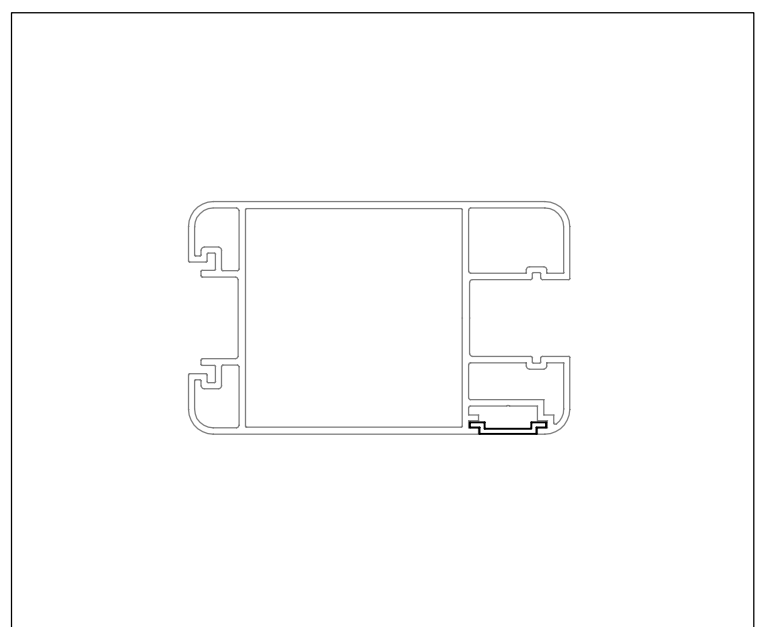
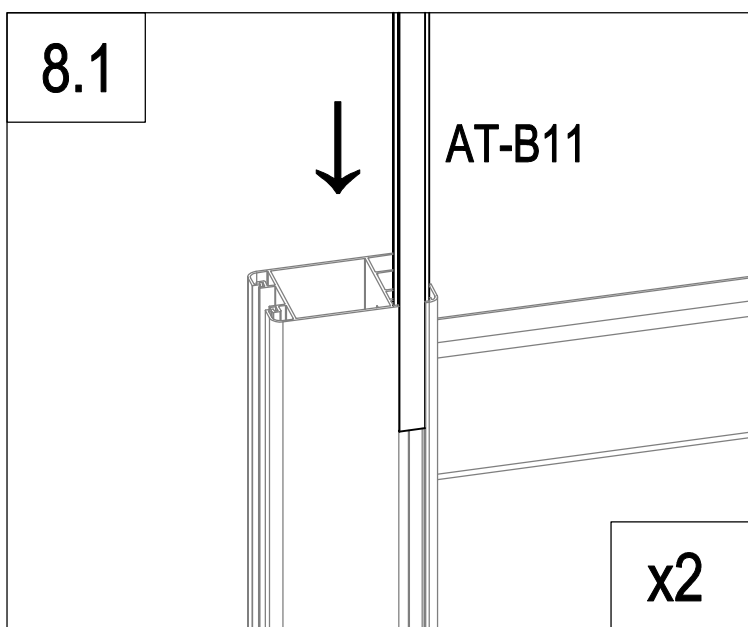
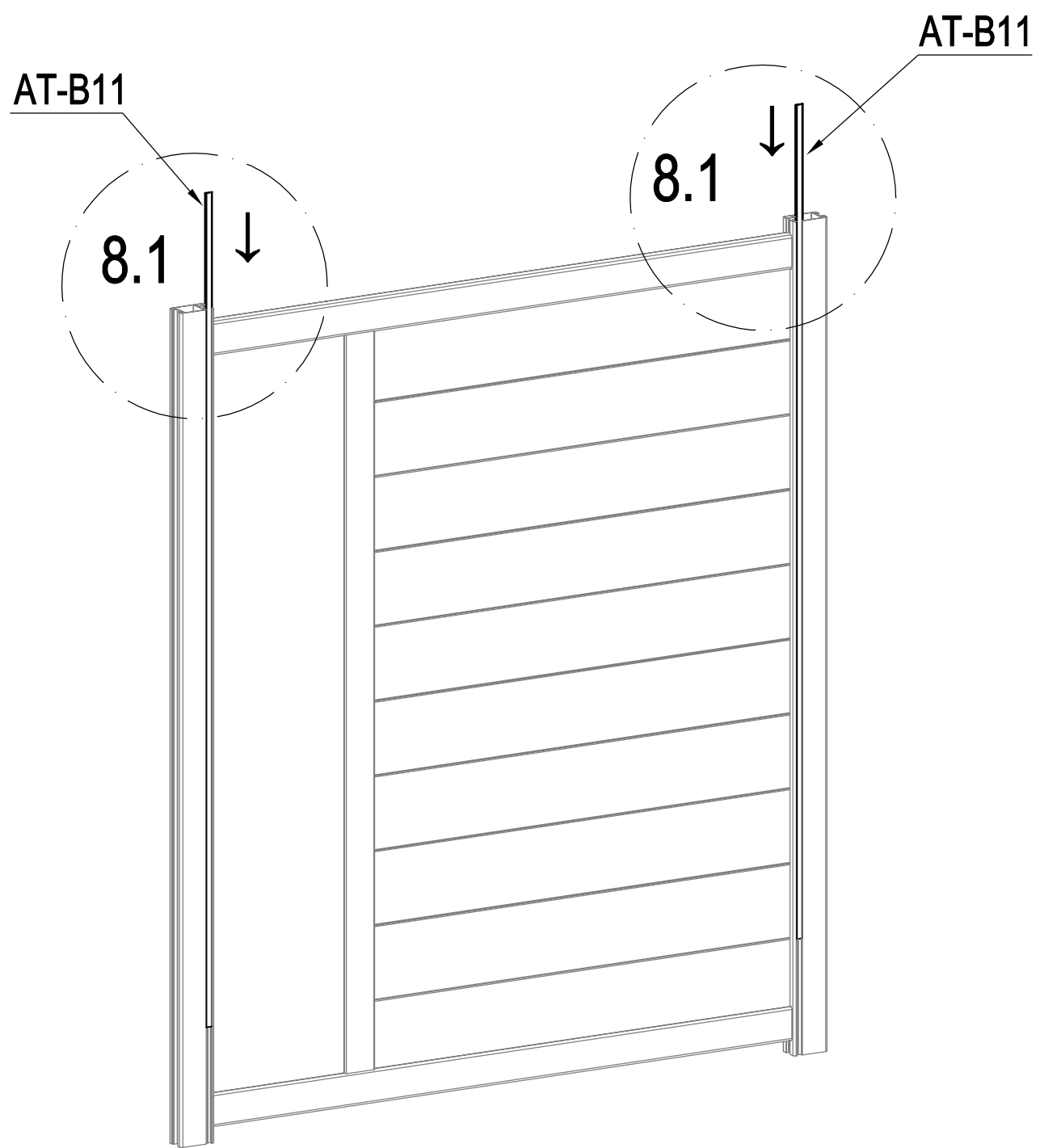

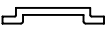
	AT-B11	2
---	--------	---

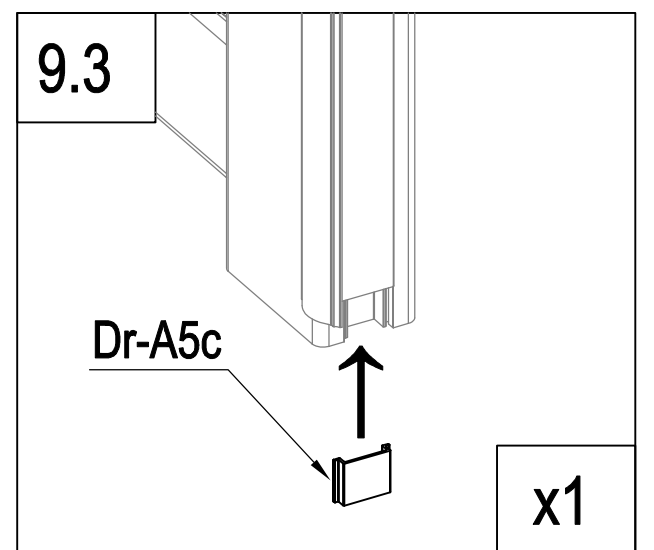
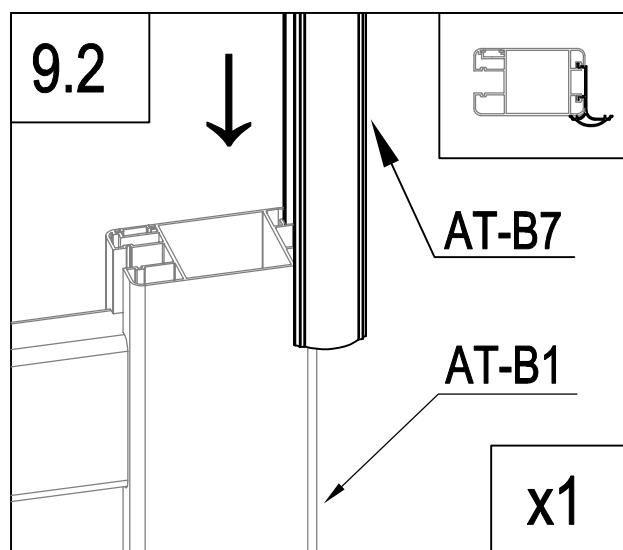
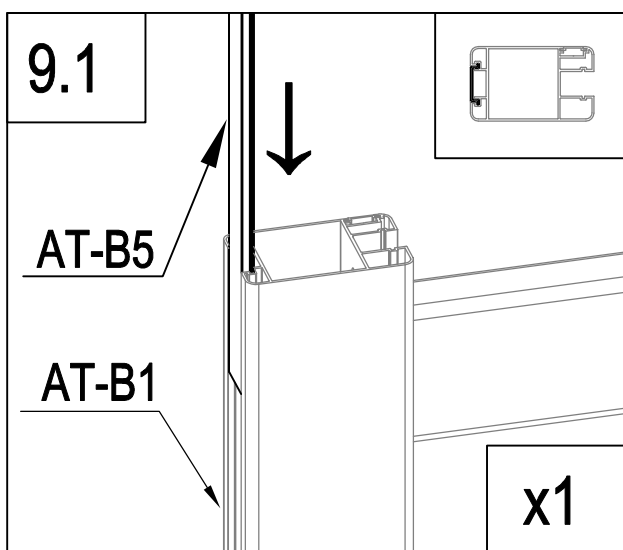
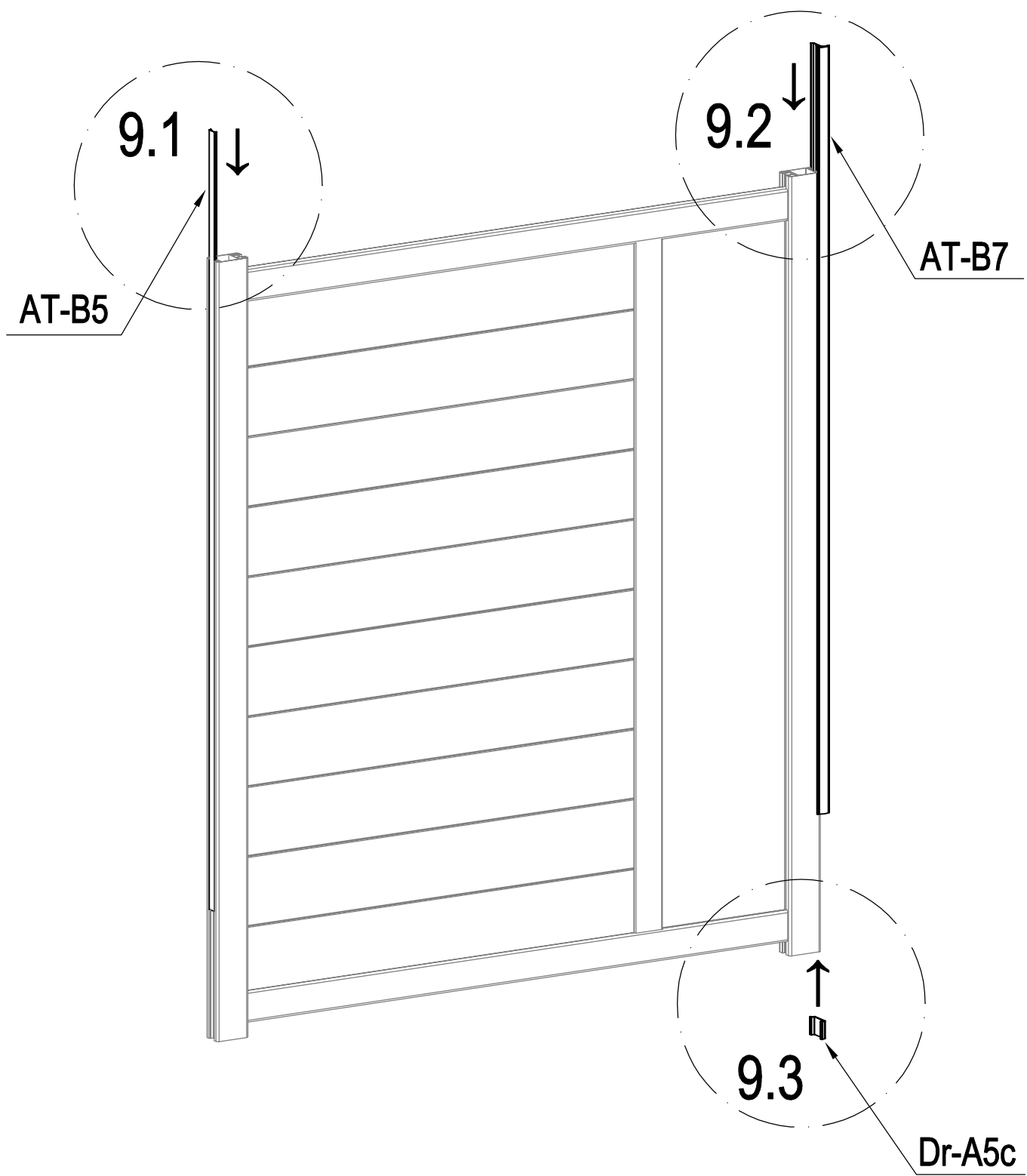
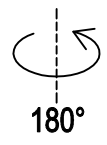

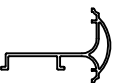
	AT-B5	1
	Dr-A5c	1
	AT-B7	1

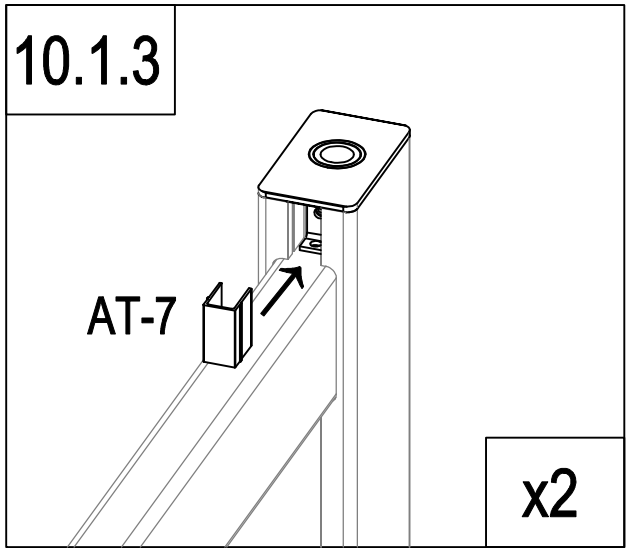
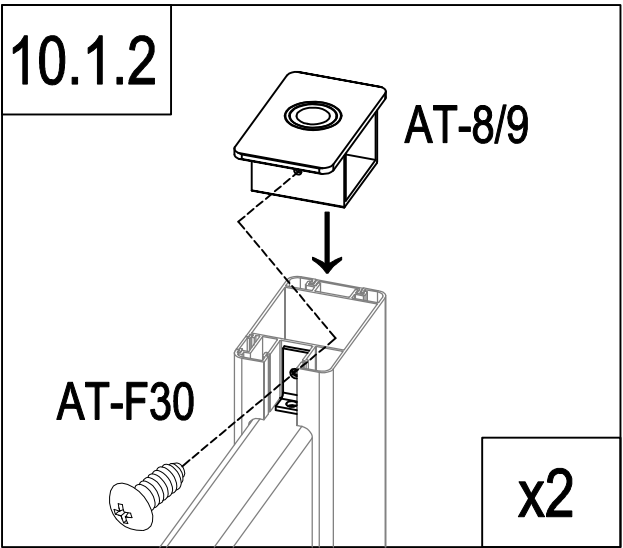
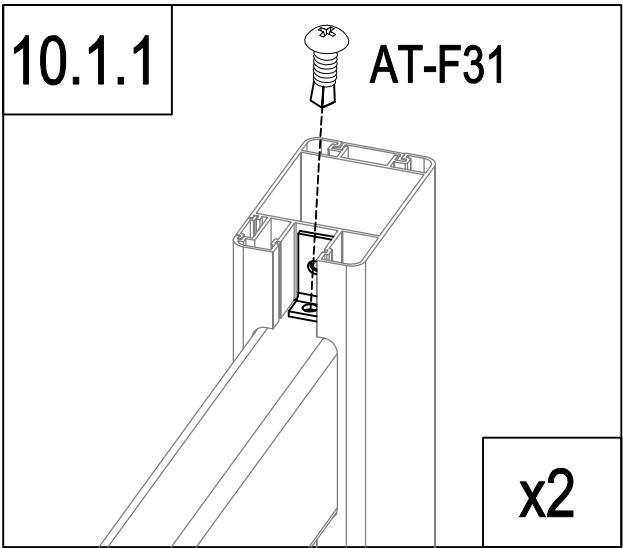
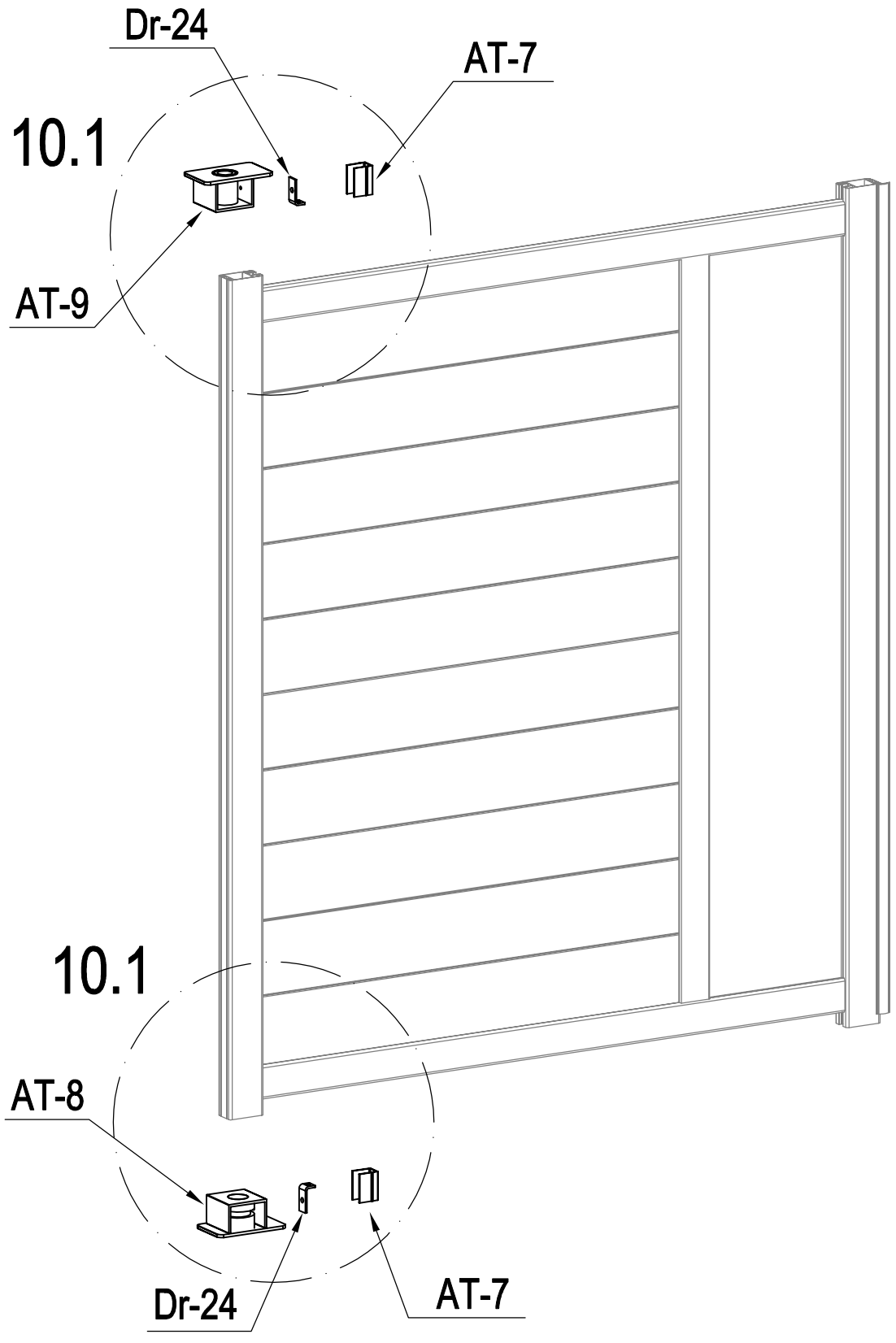

	AT-8	1
	AT-9	1
	AT-7	2

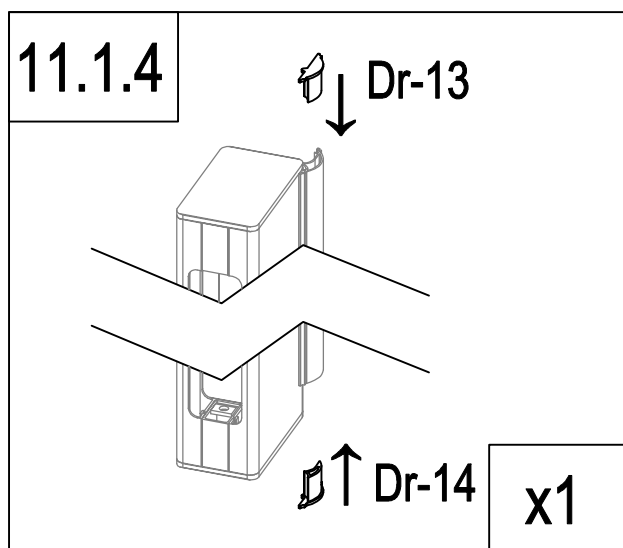
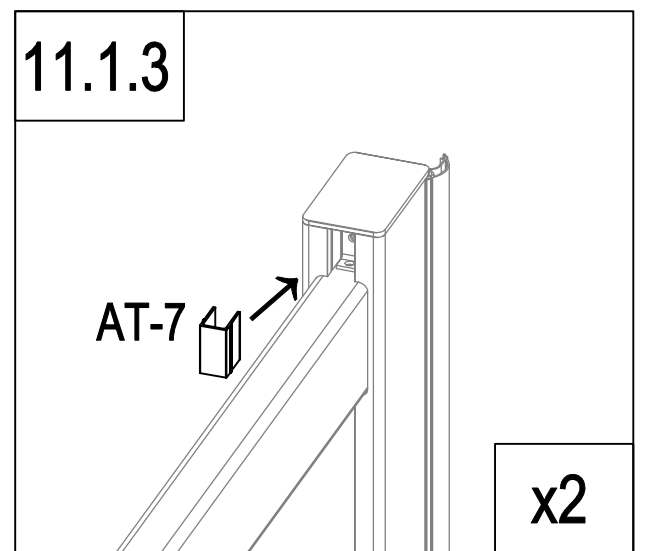
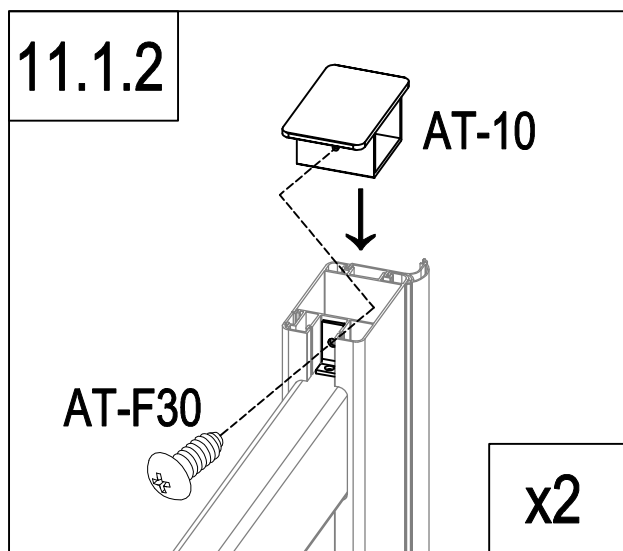
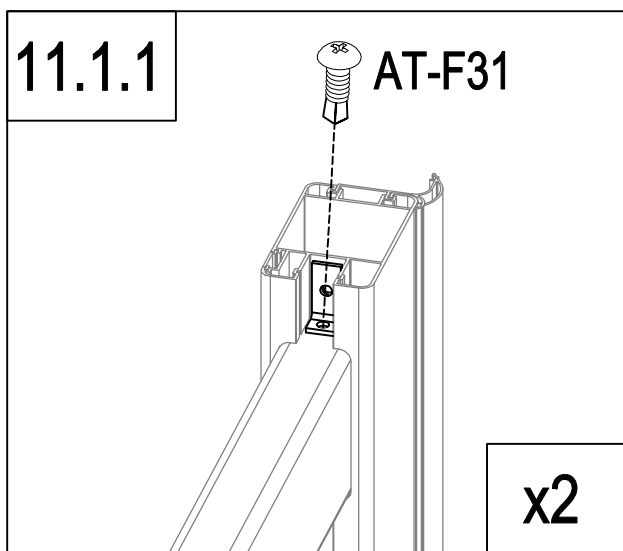
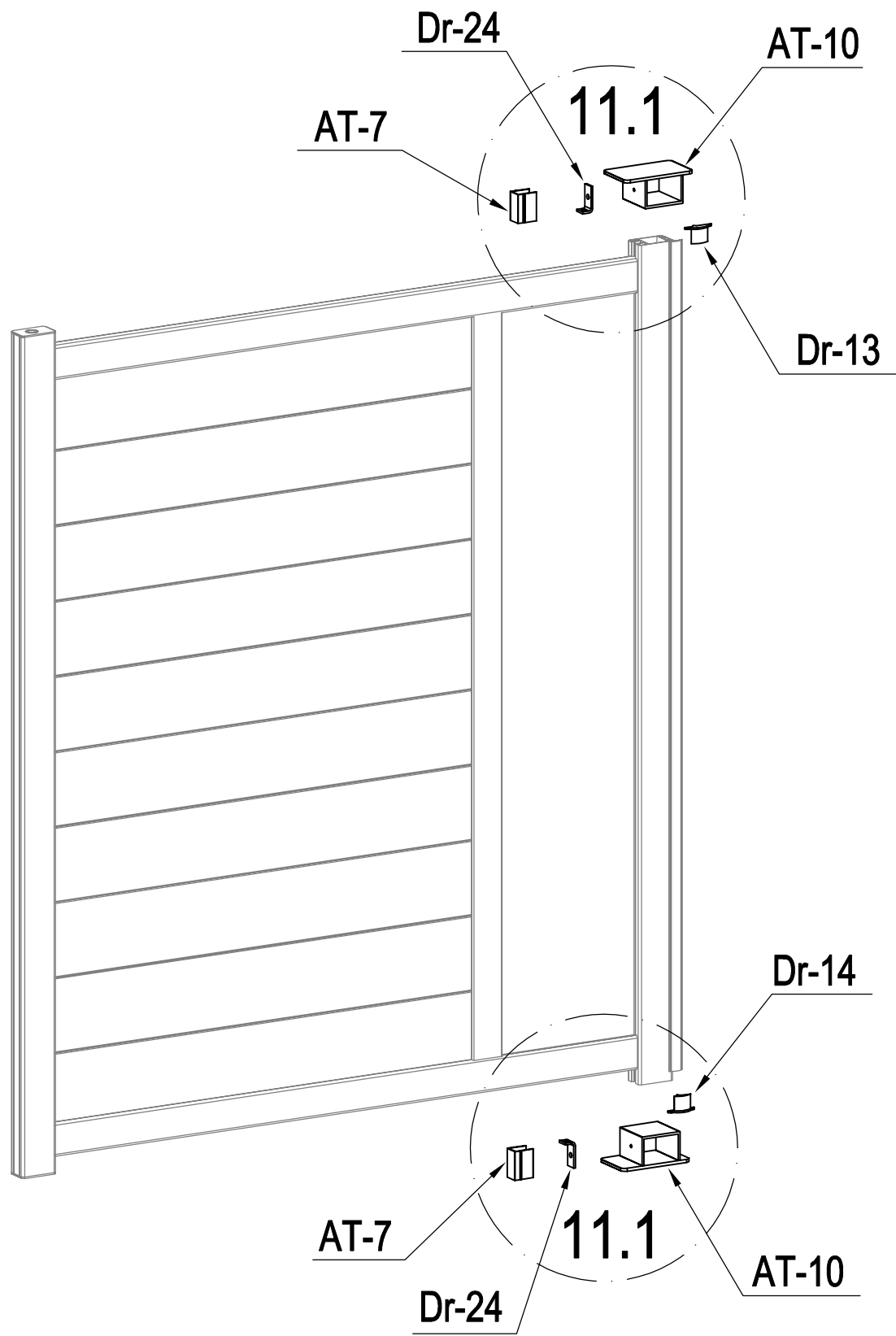

	Dr-24	2
	AT-F30	2
	AT-F31	2



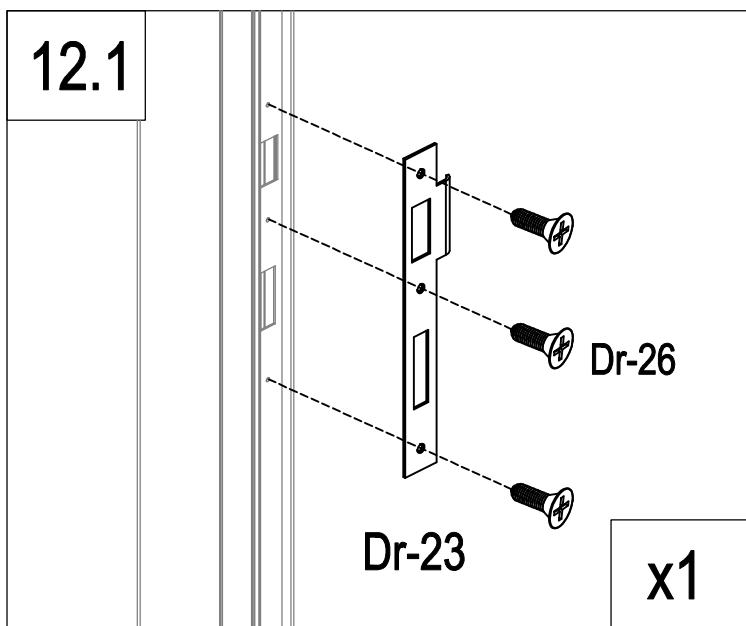
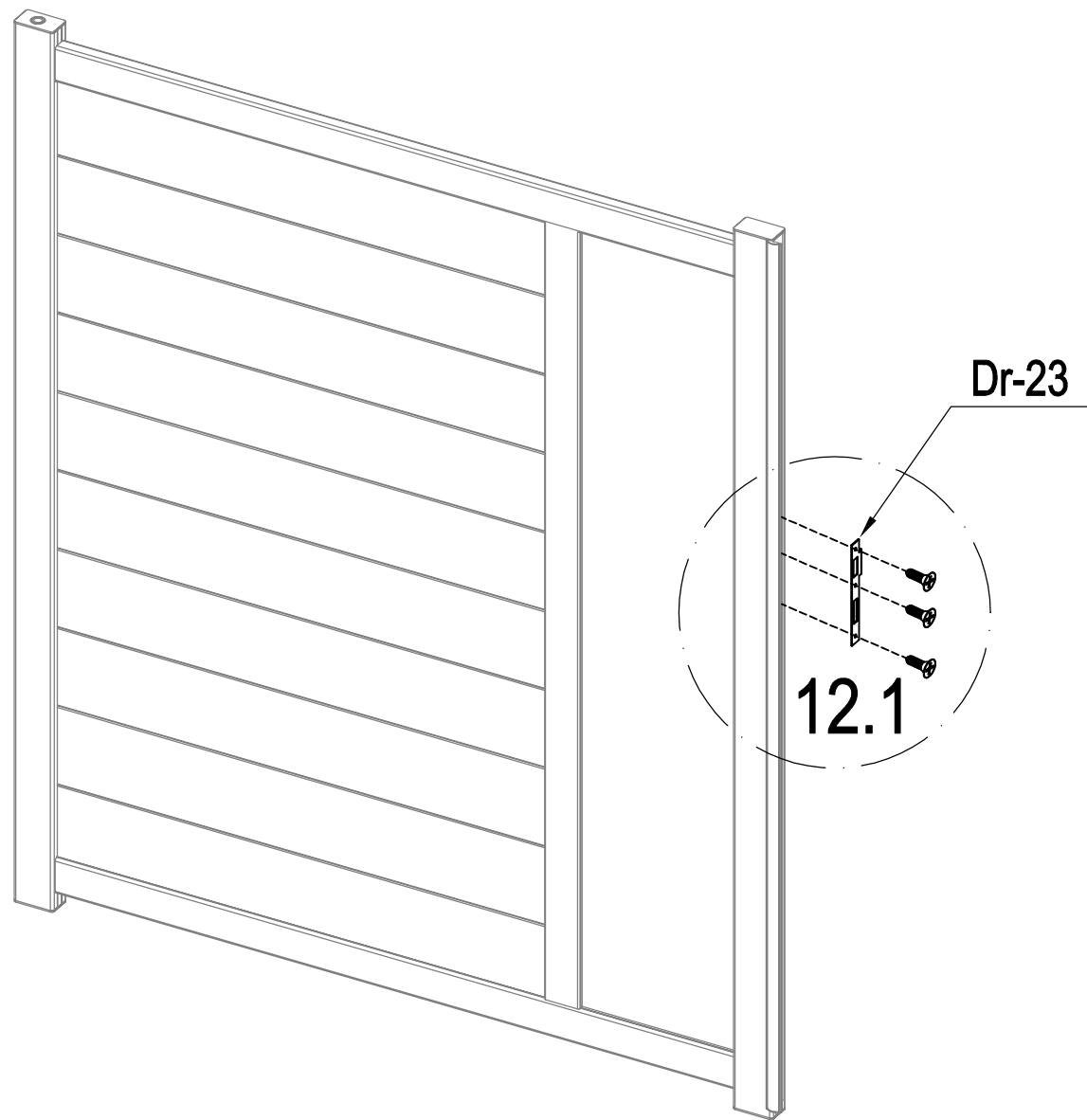

	AT-10	2
	AT-7	2
	Dr-24	2
	Dr-13	1

	DR-14	1
	AT-F30	2
	AT-F31	2

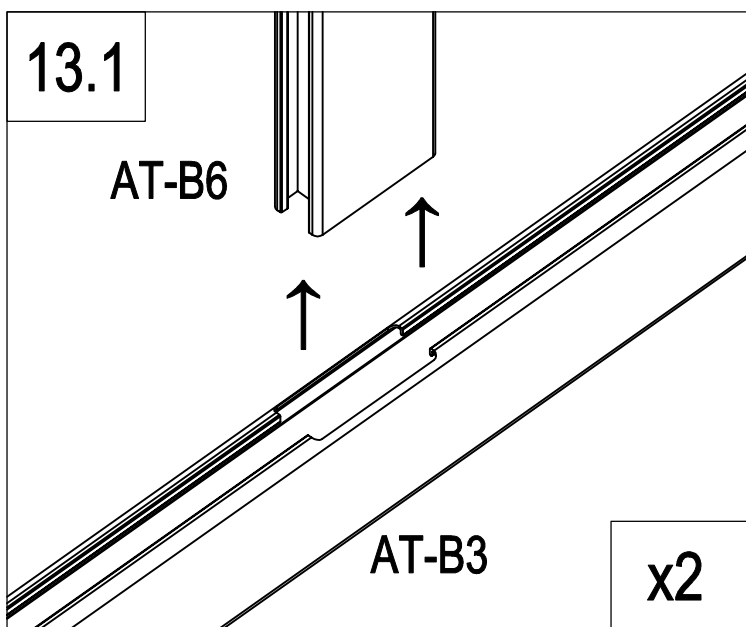
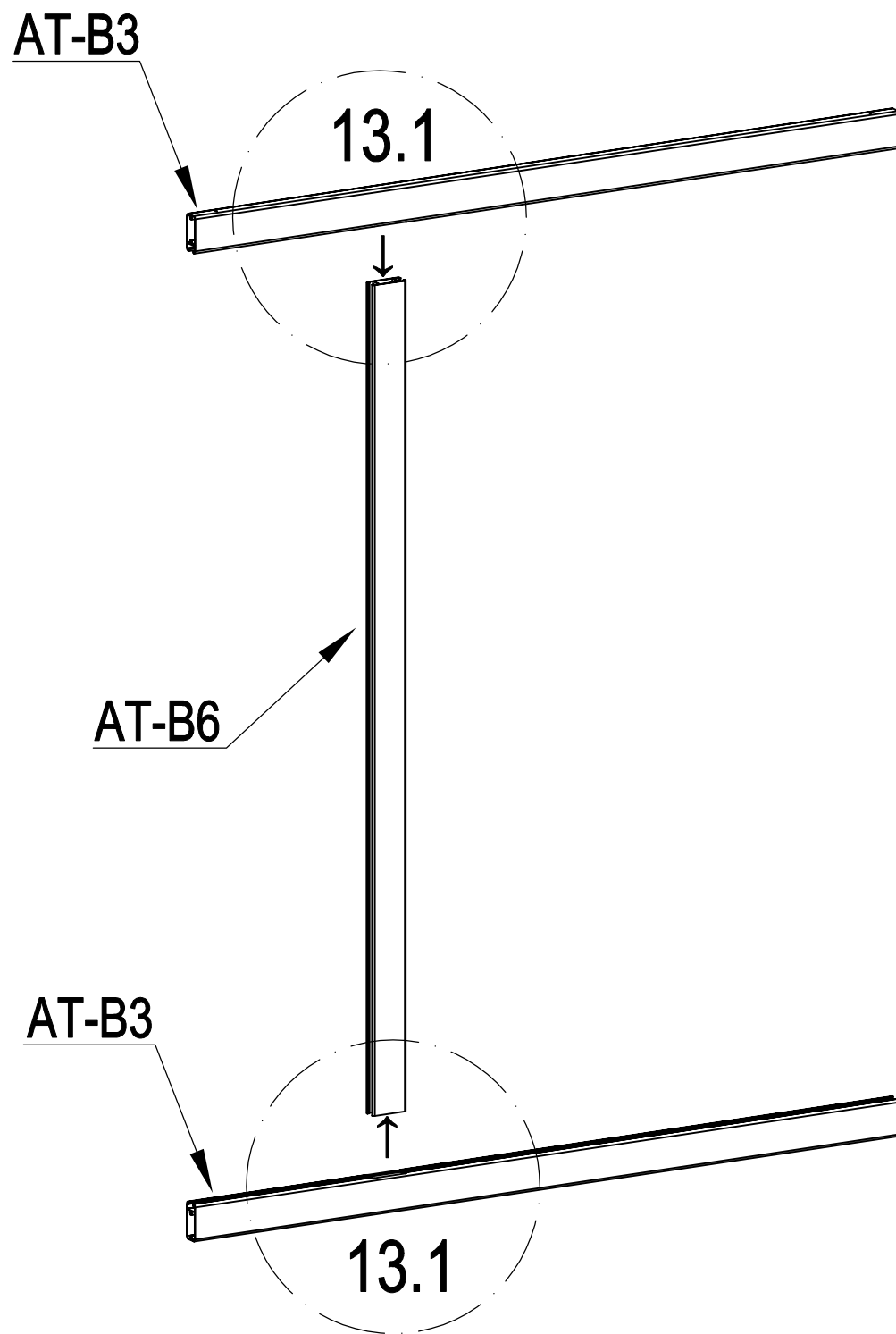

	Dr-23	1
	Dr-26	3



	AT-B6	1
	AT-B3	2

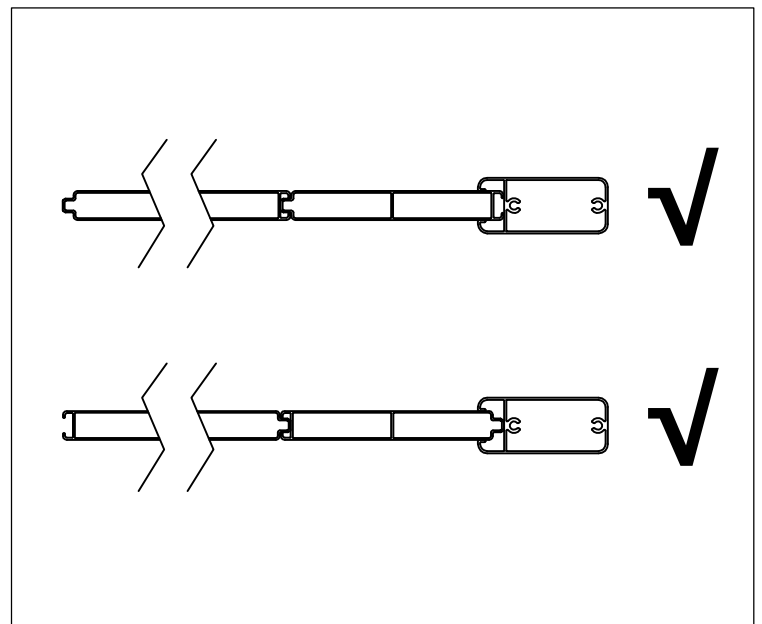
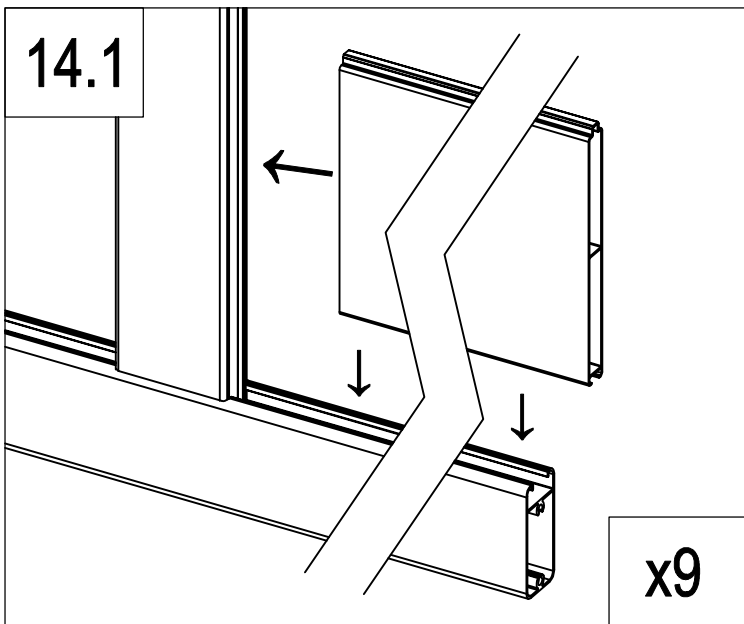
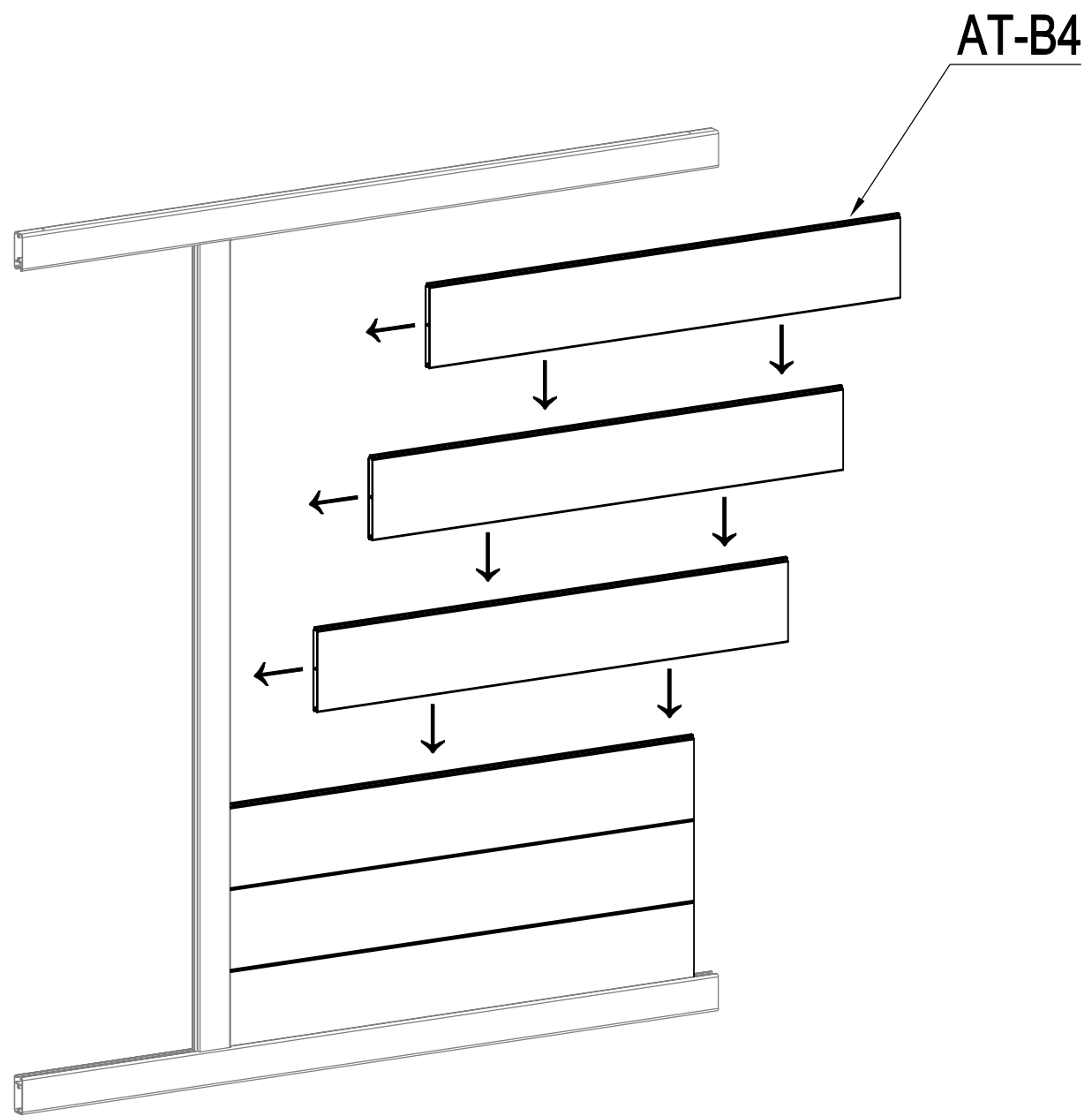

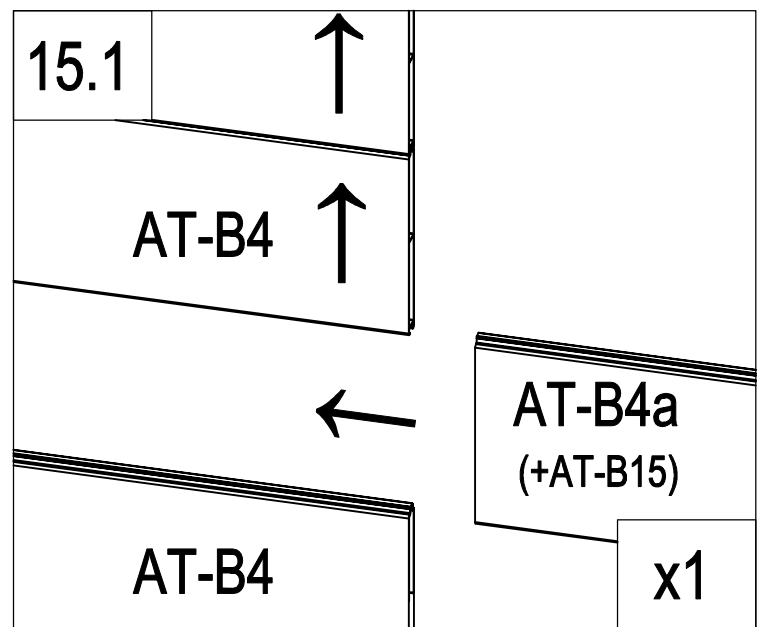
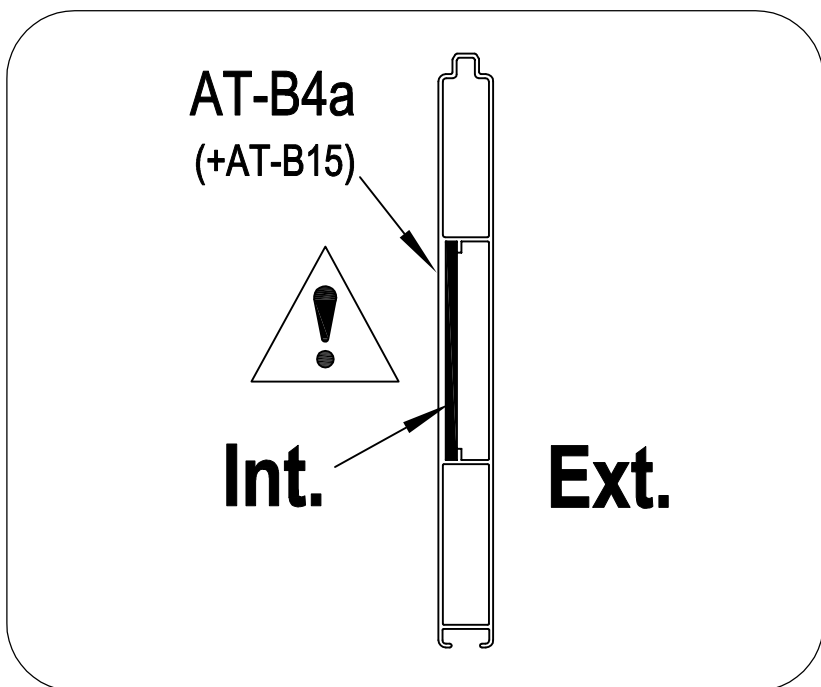
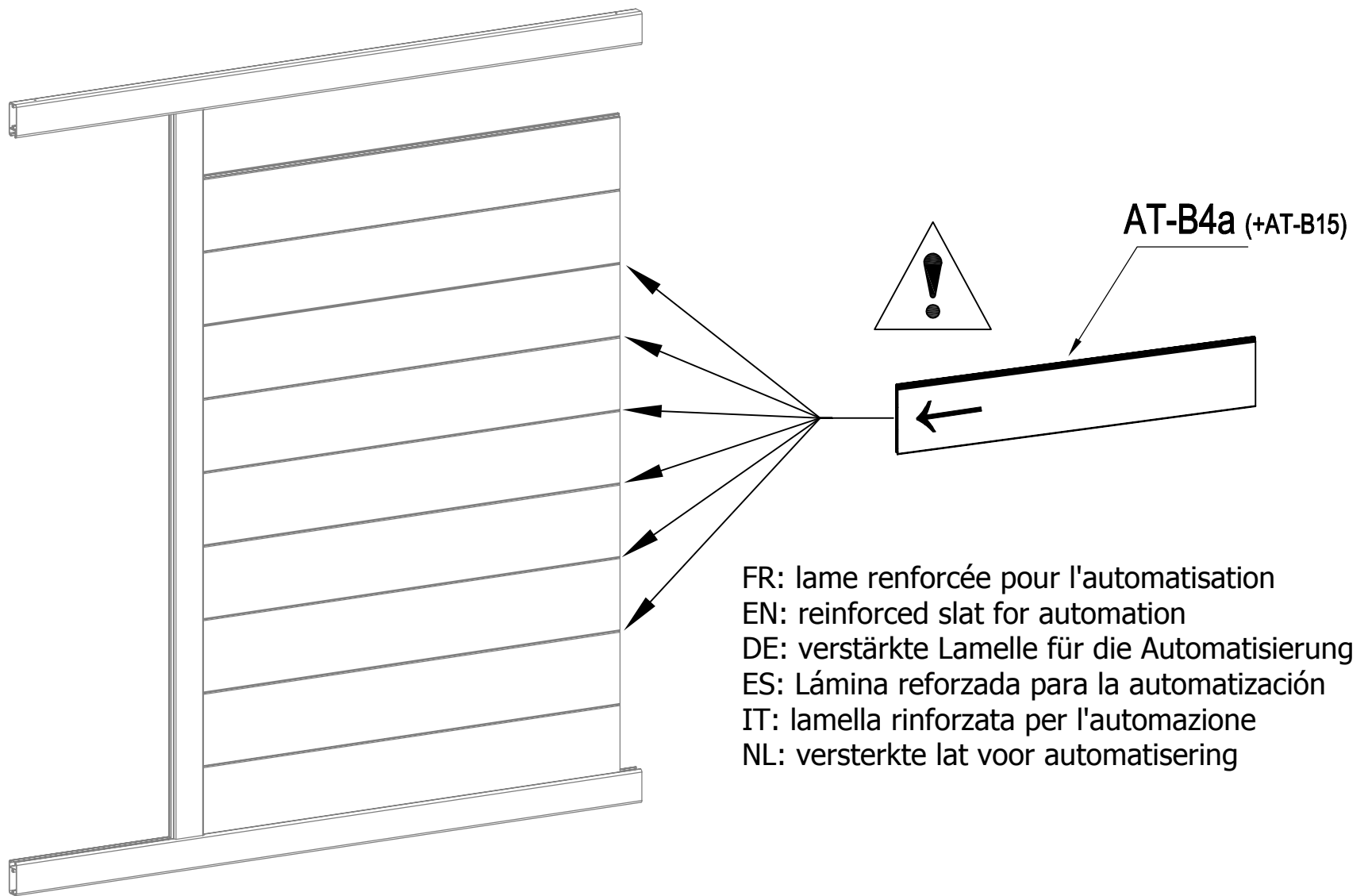

	AT-B4	9
---	-------	---

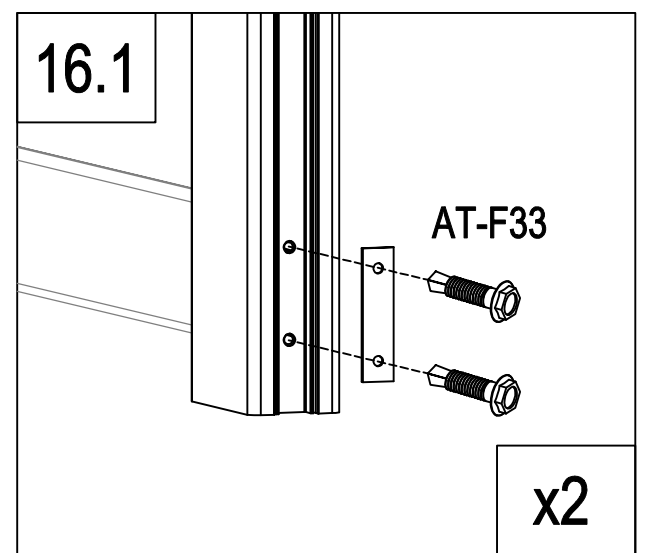
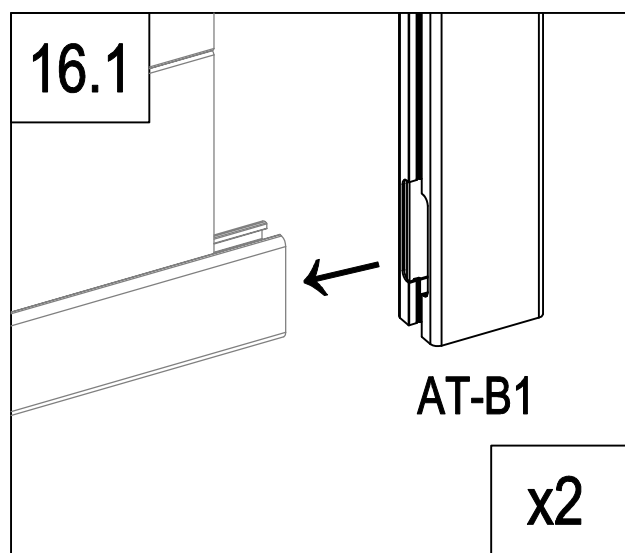
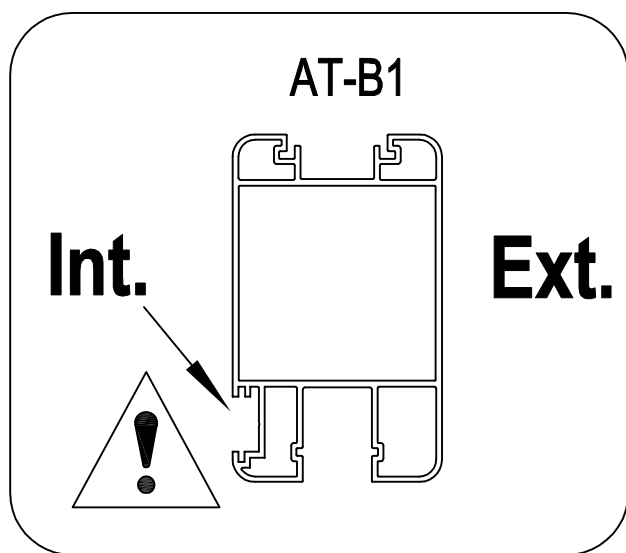
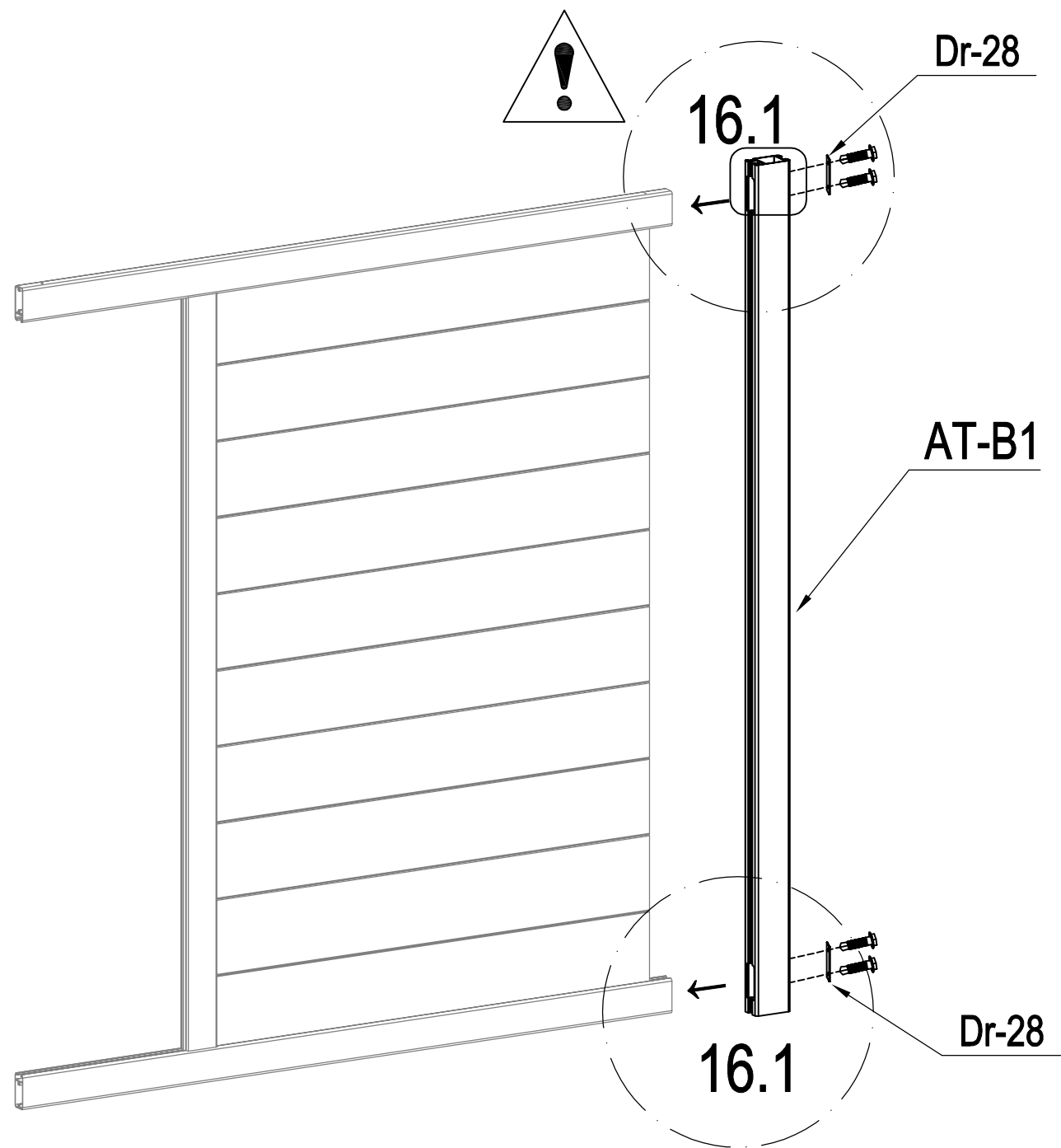

	AT-B4a (+AT-B15)	1
---	------------------	---

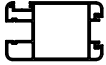

	AT-B1	1
	Dr-28	2
	AT-F33	4

FR: vous pouvez retourner et changer la direction de cette plaque pour personnaliser votre portail

EN: you can flip and switch the direction of this plate to personalize your gate





DE: Sie können dieses Schild umdrehen und die Richtung wechseln, um Ihr Tor zu personalisieren.

ES: puedes girar y cambiar la dirección de esta placa para personalizar tu puerta

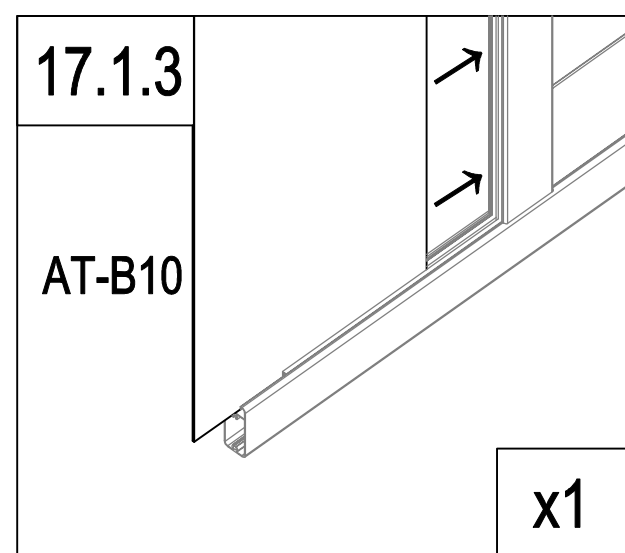
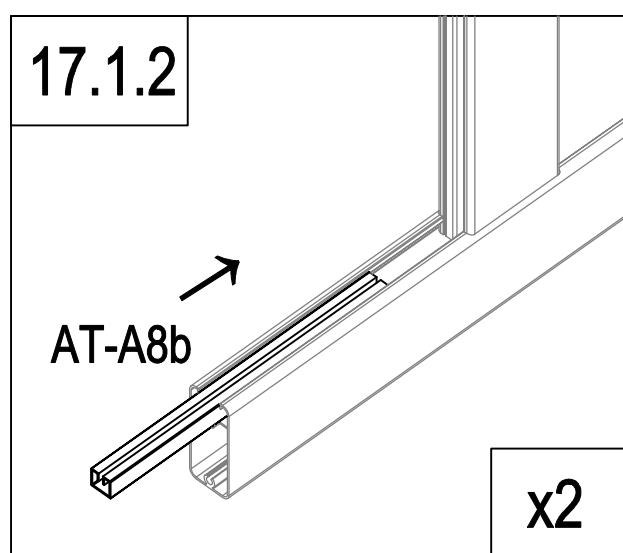
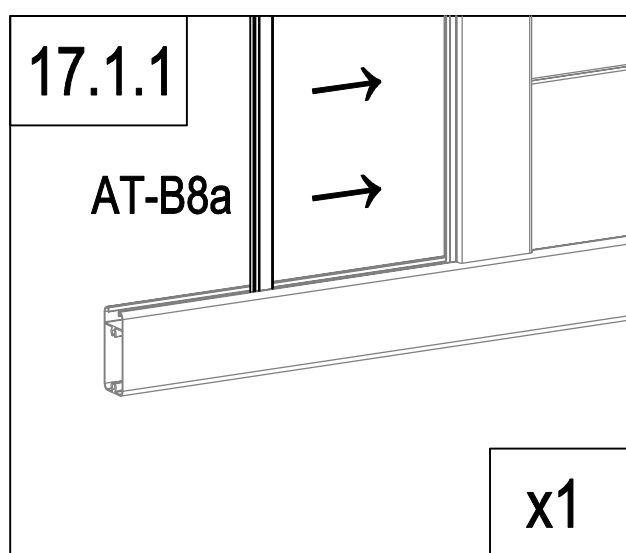
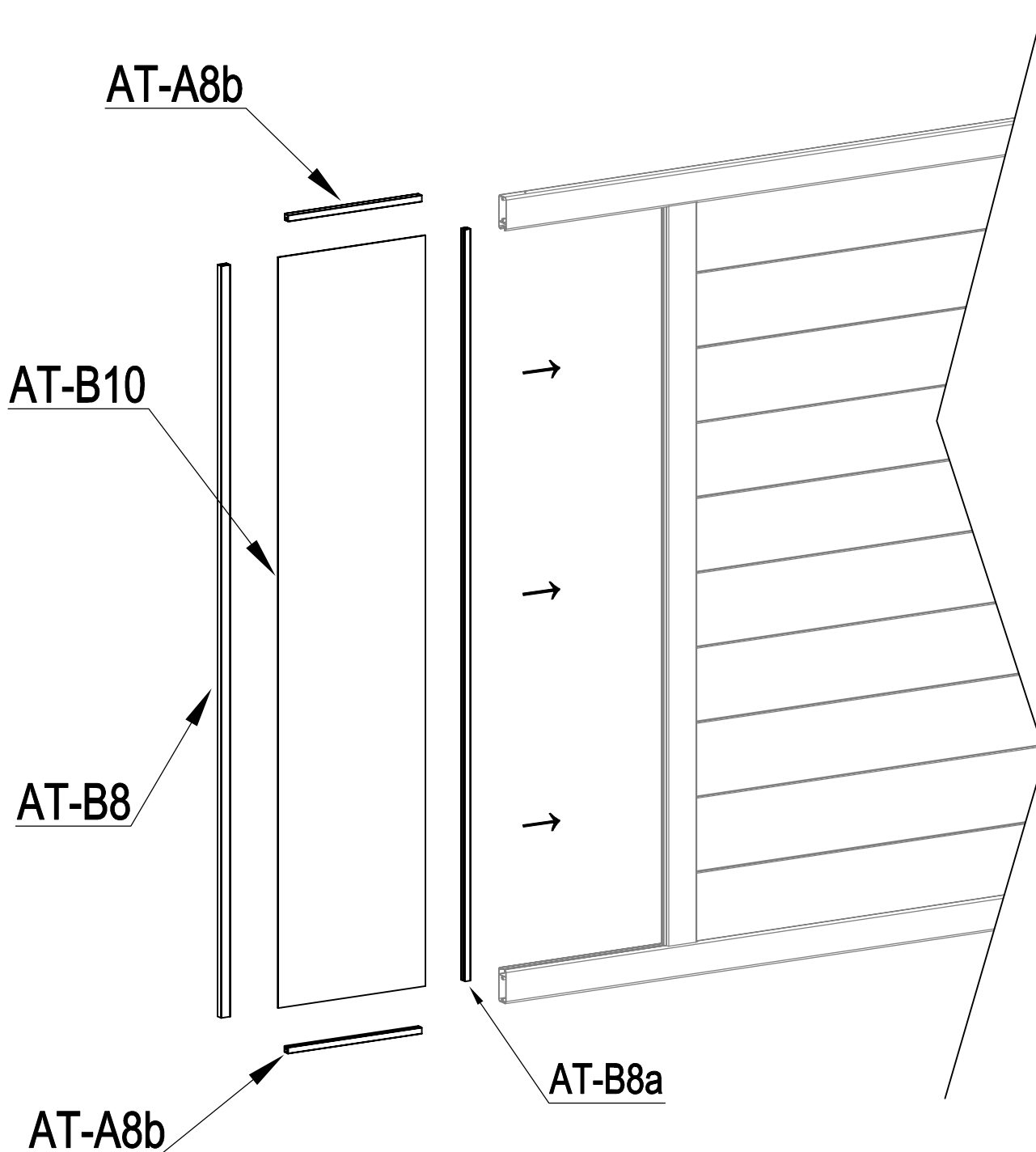
IT: potete capovolgere e cambiare la direzione di questa piastra per personalizzare il vostro cancello



NL: u kunt de richting van deze plaat omdraaien en veranderen om uw poort te verpersoonlijken...

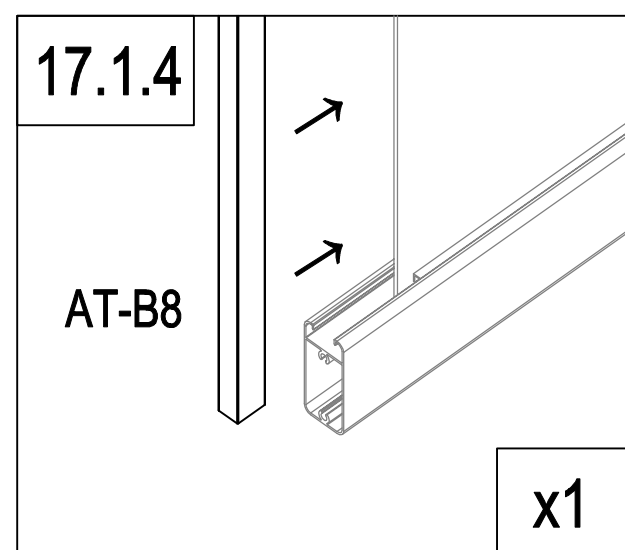

	AT-B8a	1
	AT-A8b	2
	AT-B10	1
	AT-B8	1

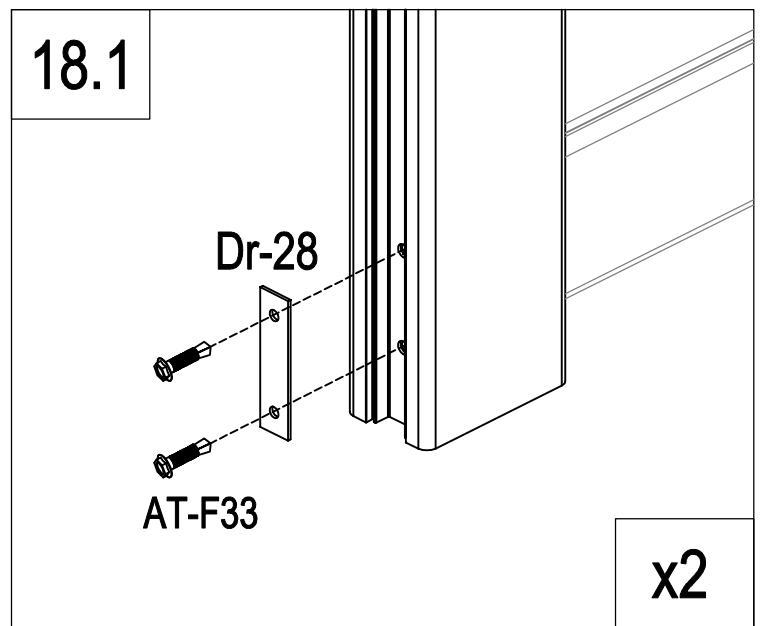
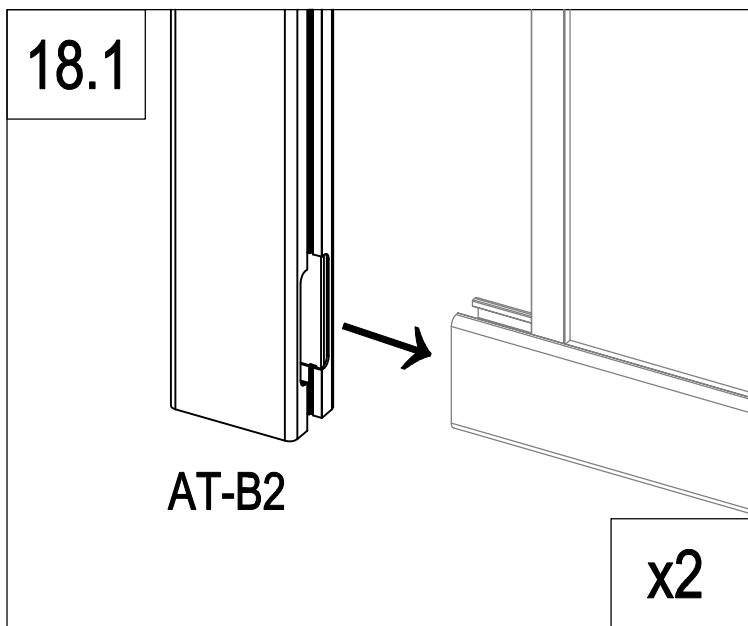
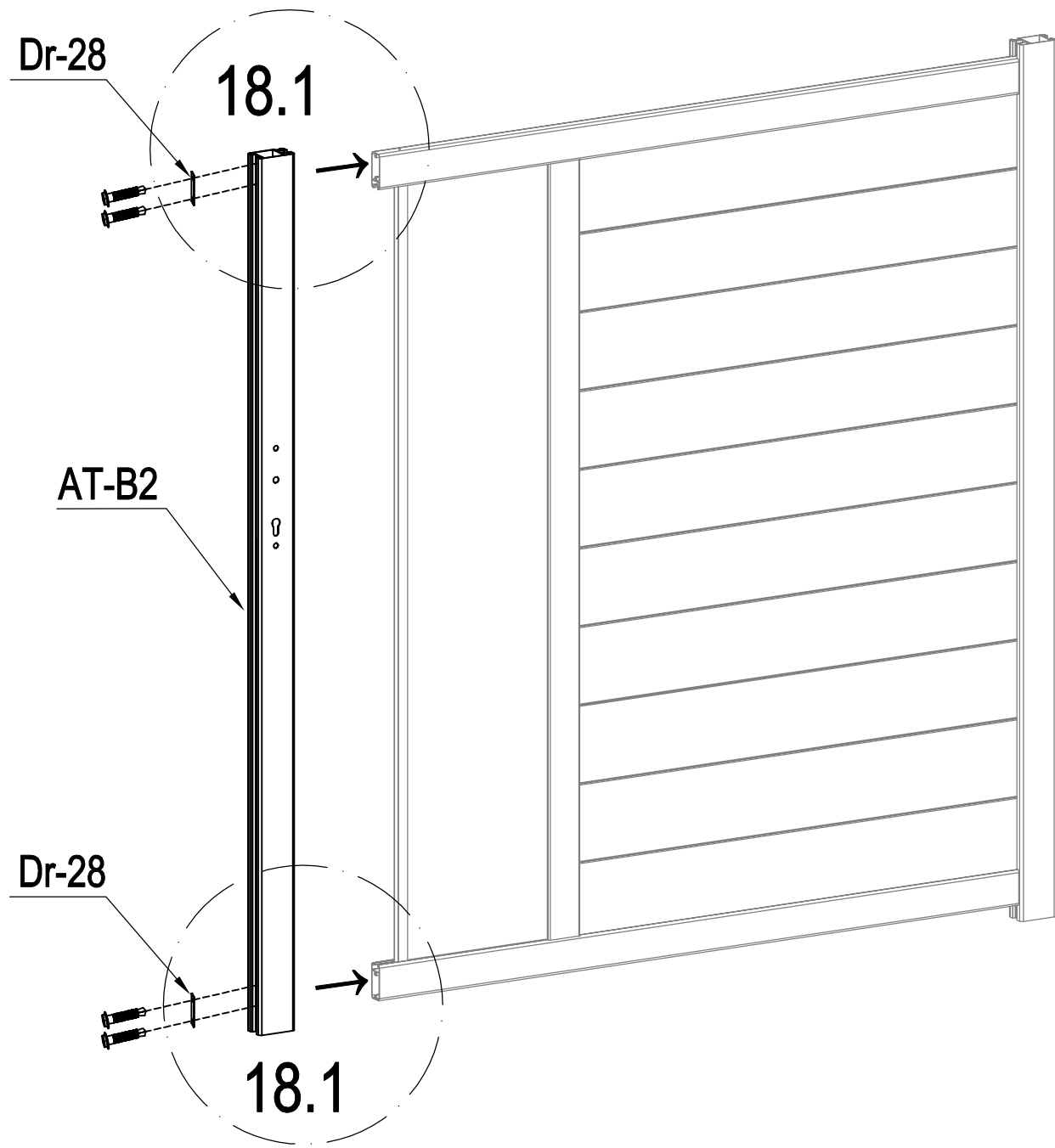

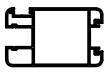

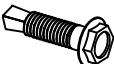
	AT-B2	1
	Dr-28	2
	AT-F33	4

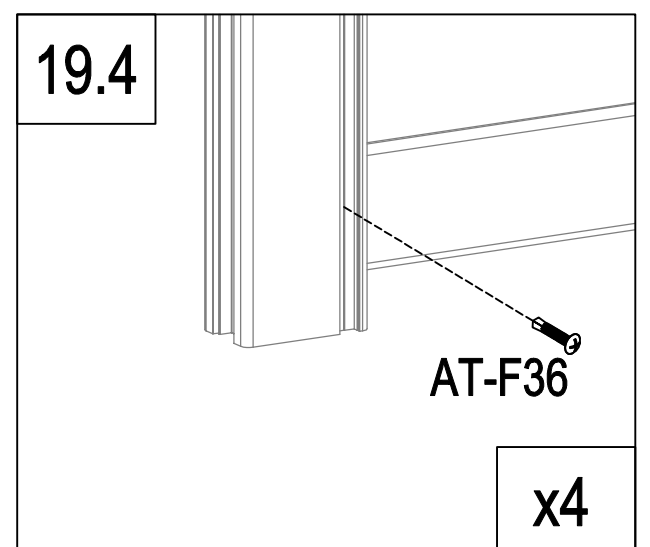
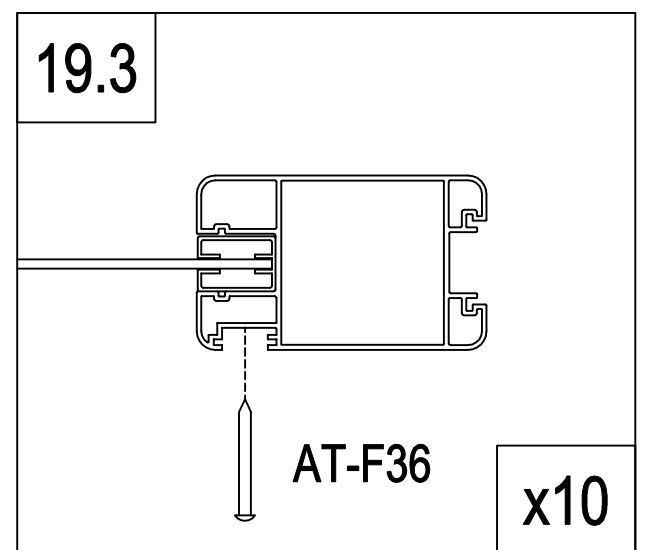
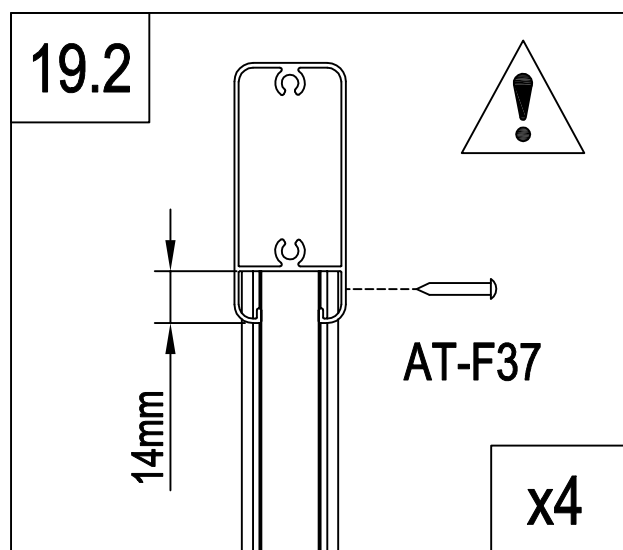
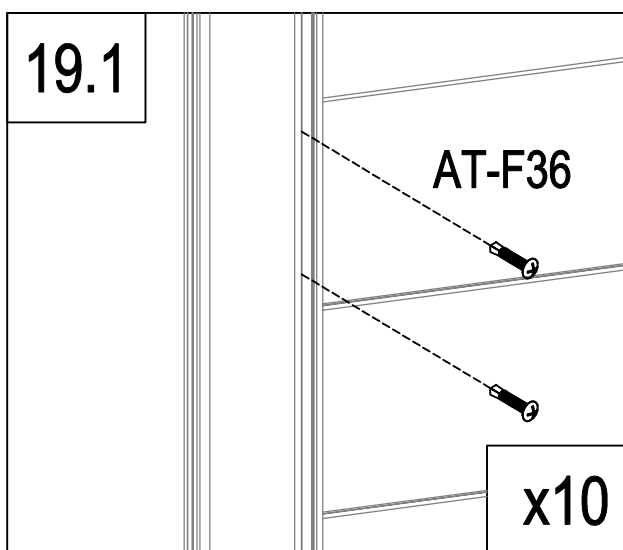
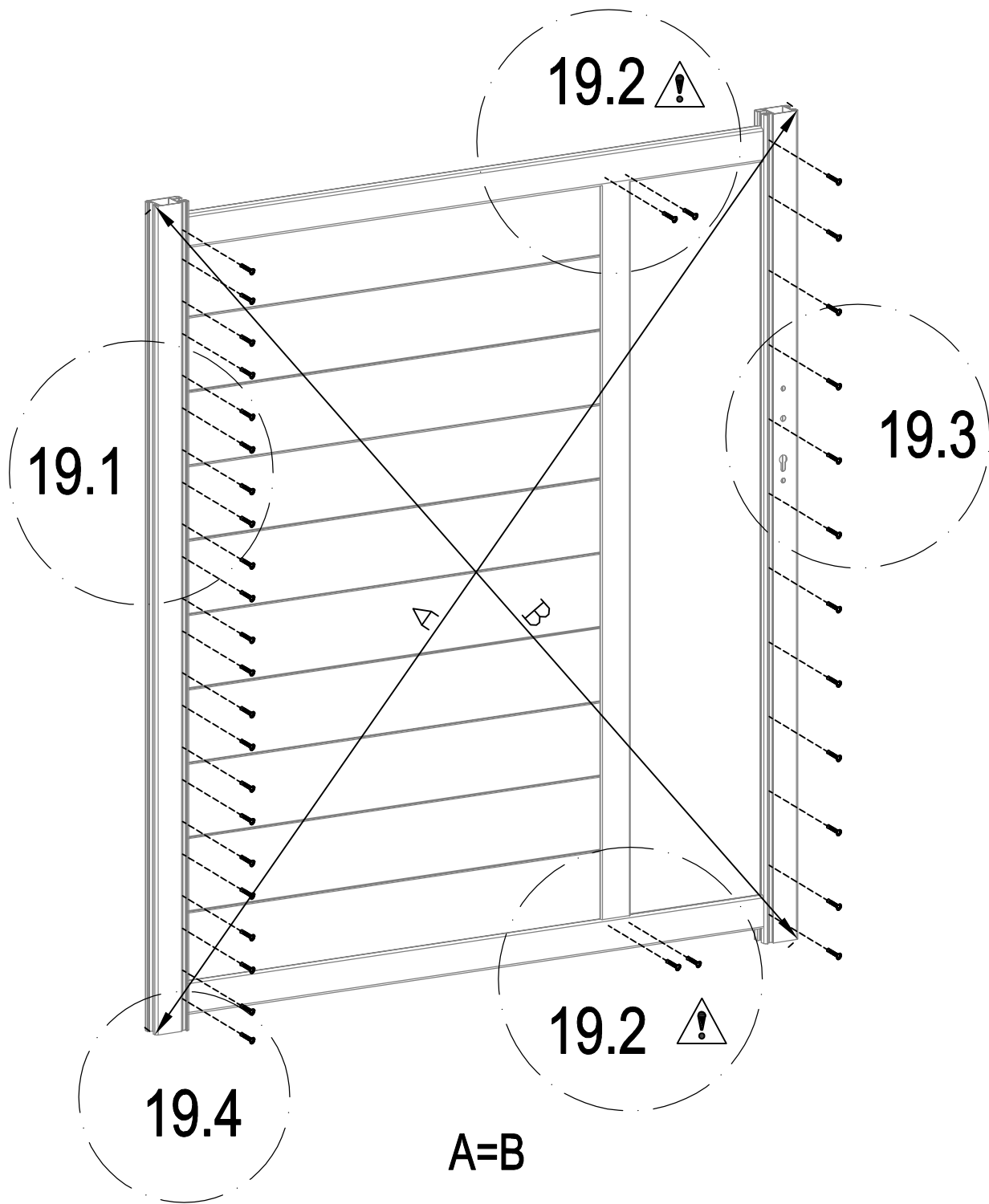
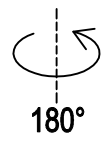

	AT-F36	34
	AT-F37	4

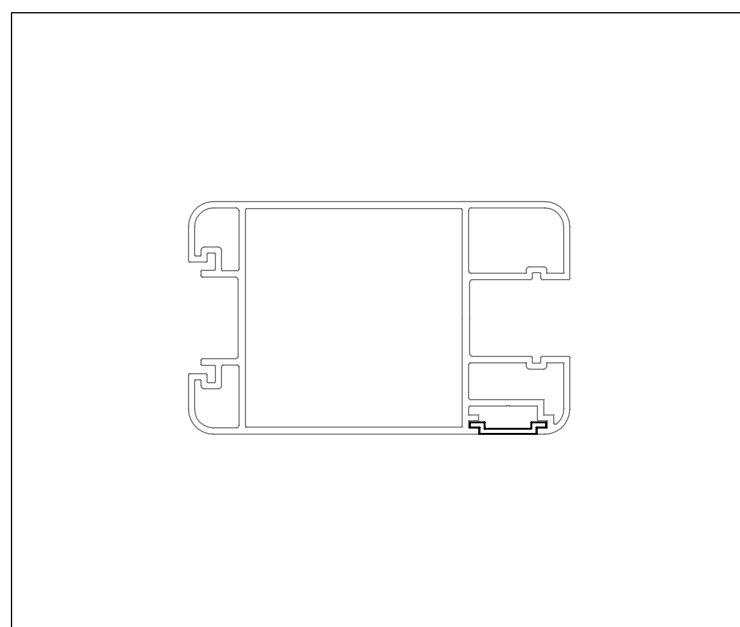
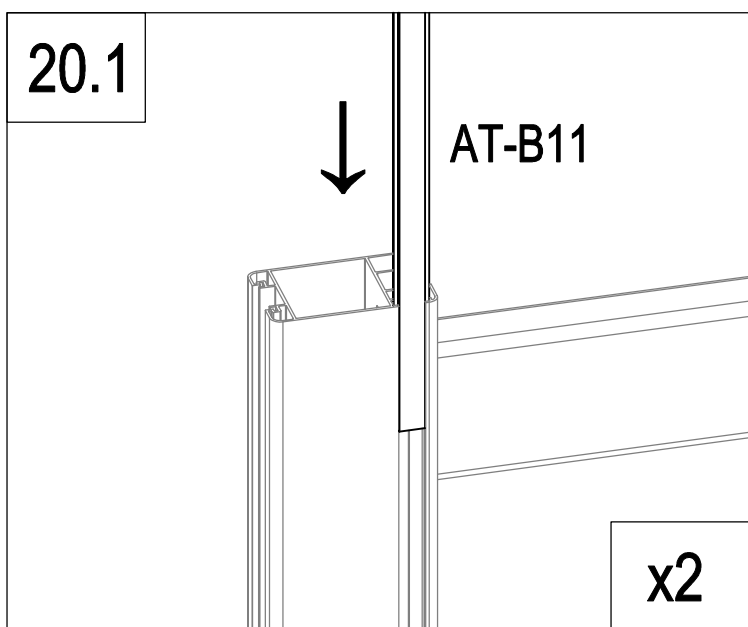
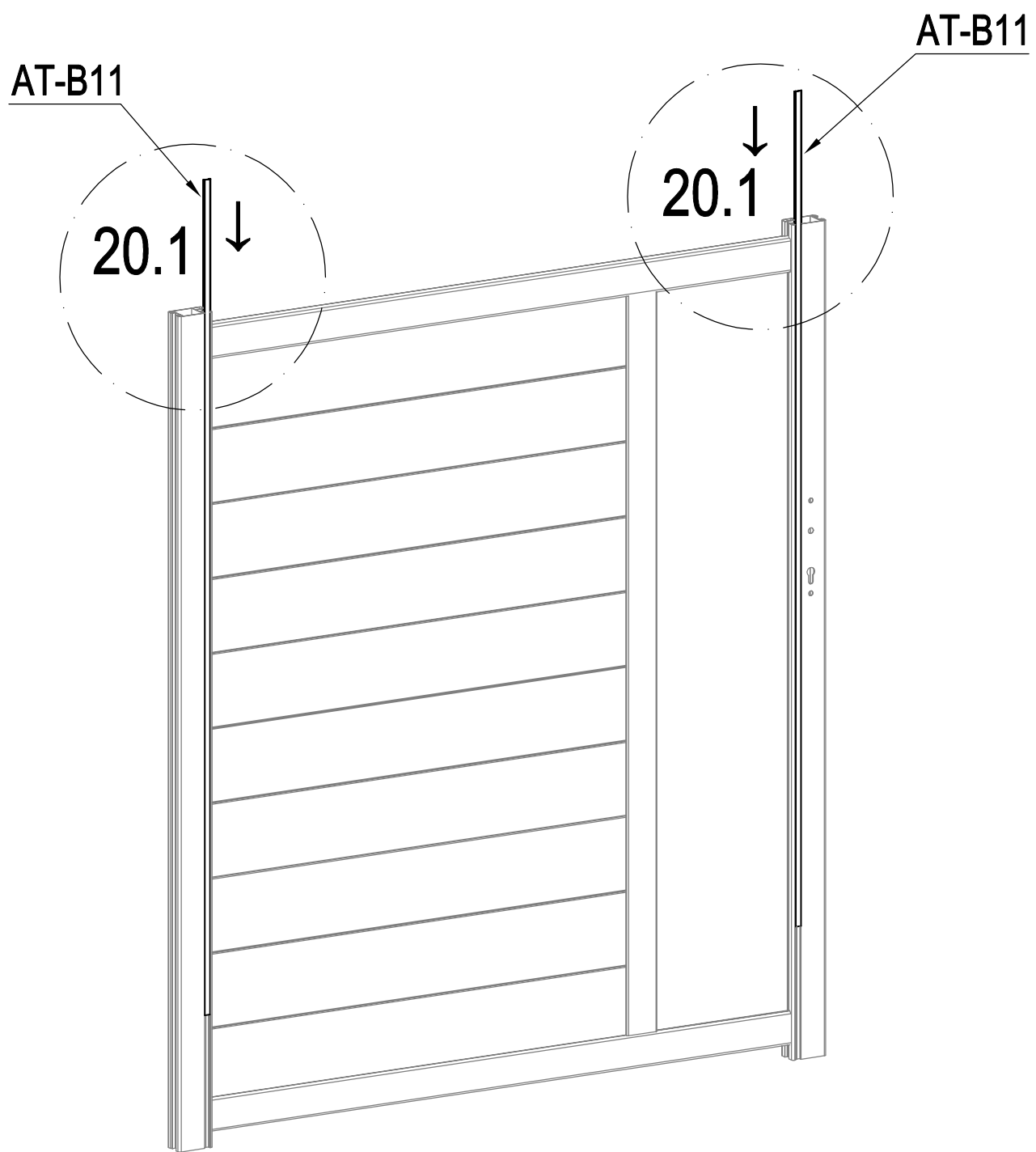

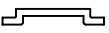
	AT-B11	2
---	--------	---

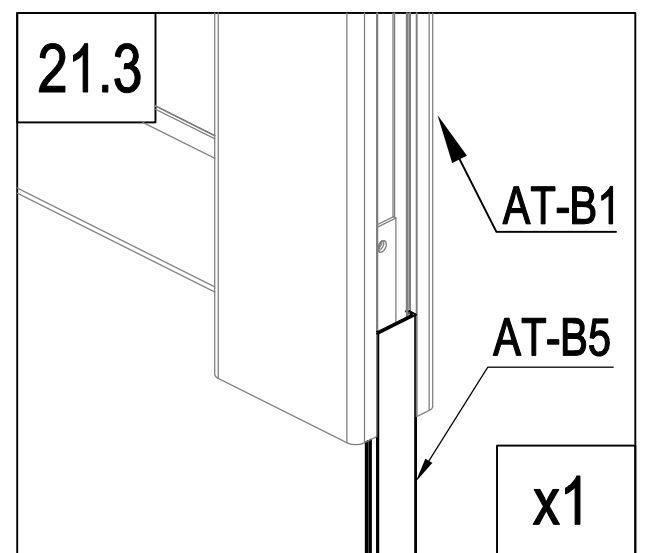
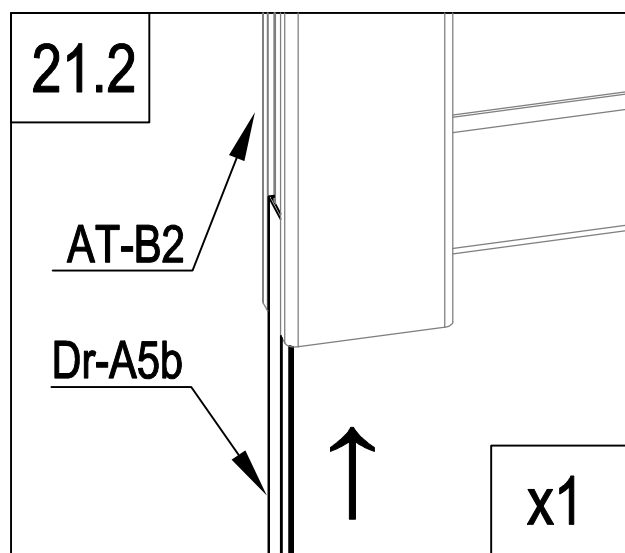
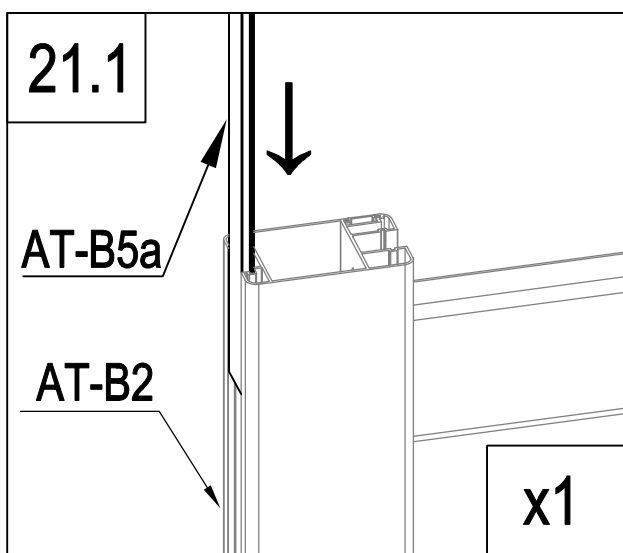
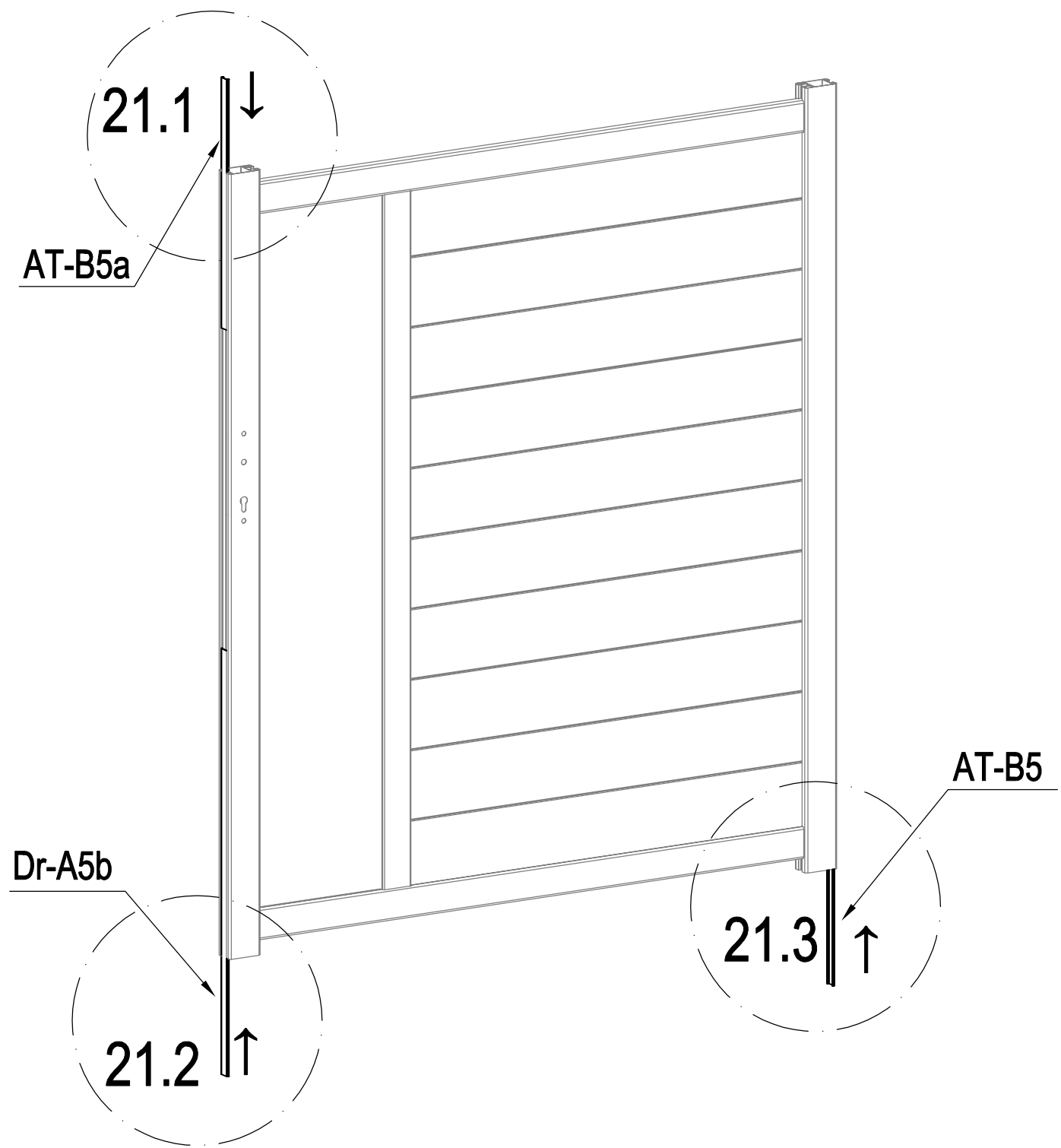
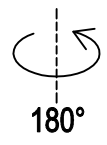

	AT-B5	1
	AT-B5a	1
	Dr-A5b	1

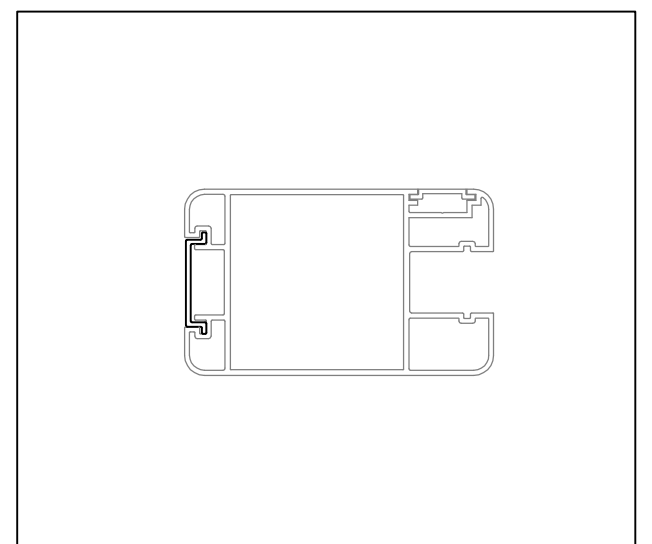

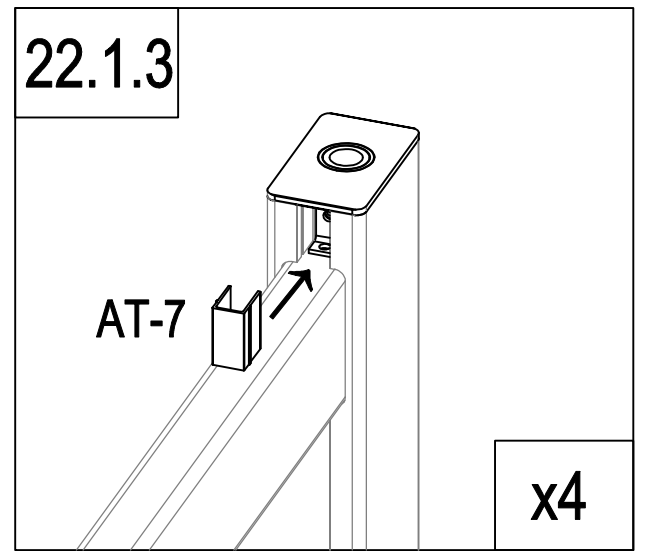
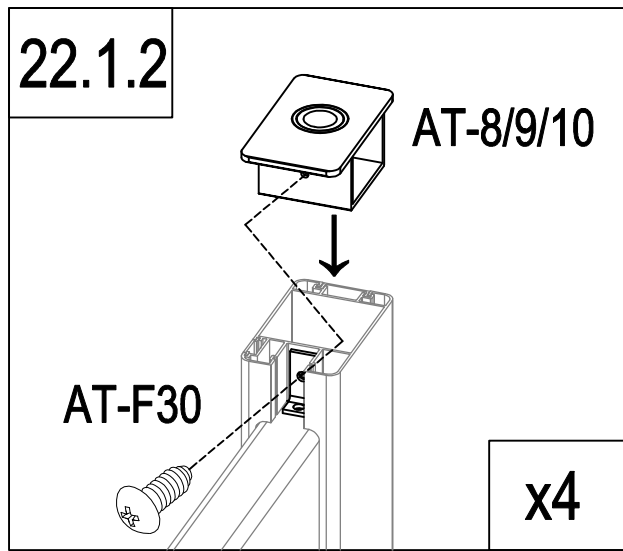
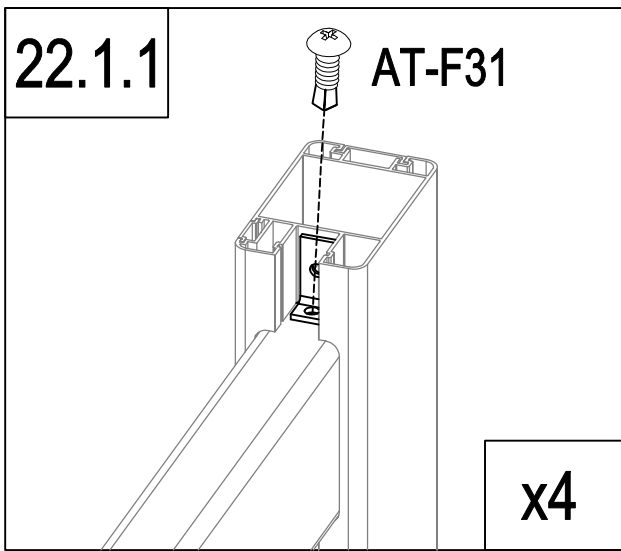
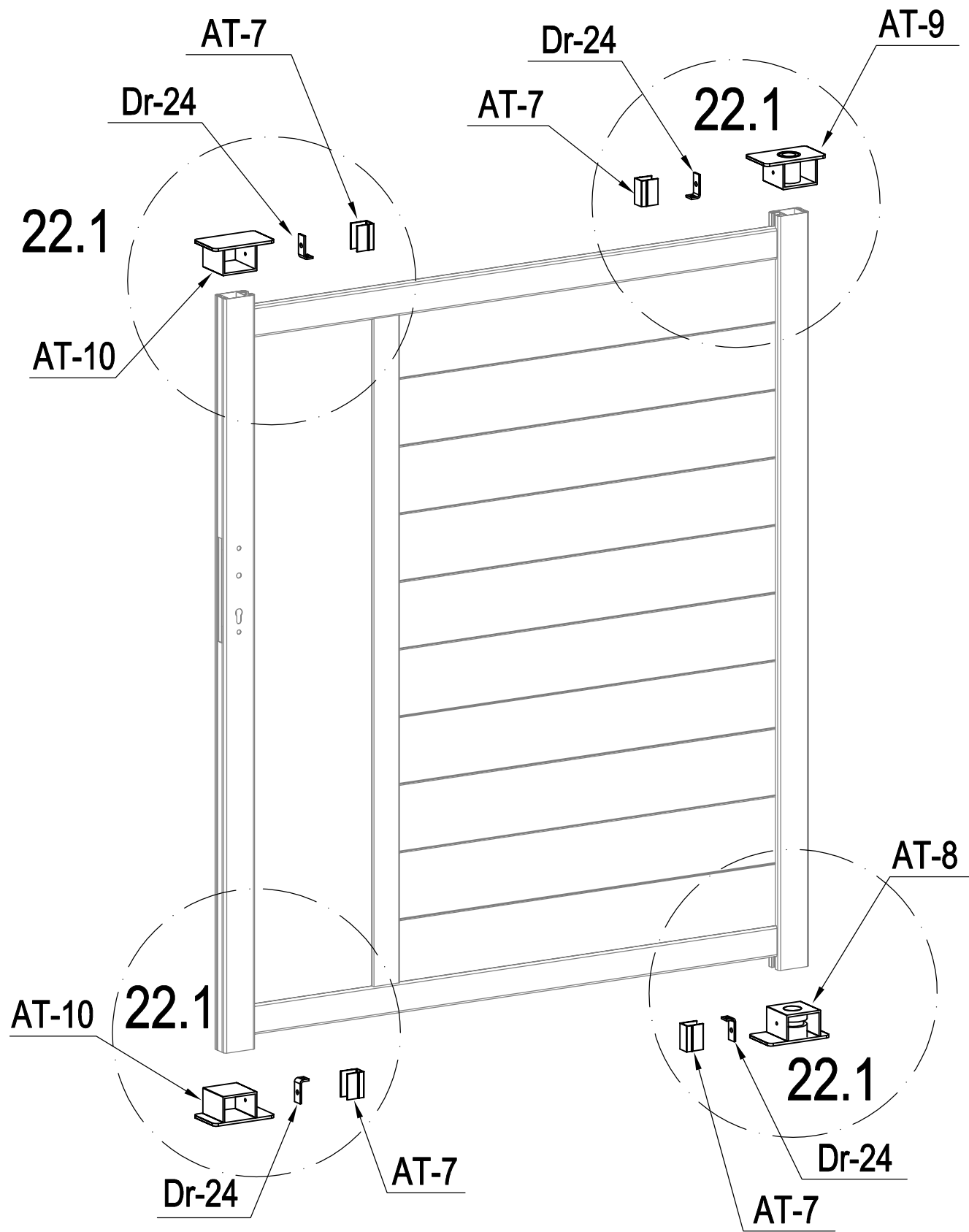

	AT-8	1
	AT-9	1
	AT-10	2
	AT-7	4

	Dr-24	4
	AT-F30	4
	AT-F31	4

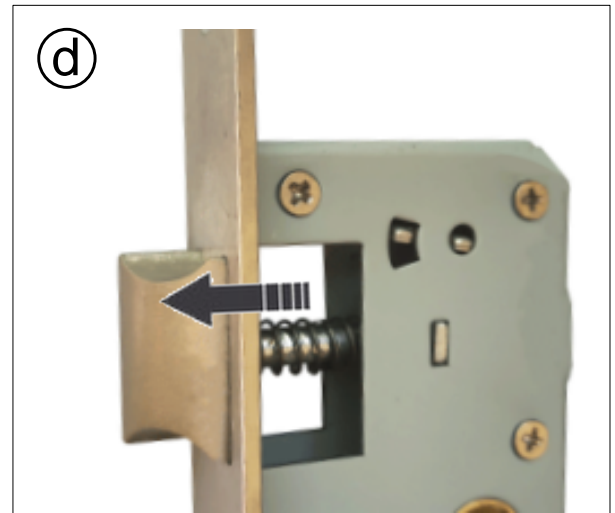
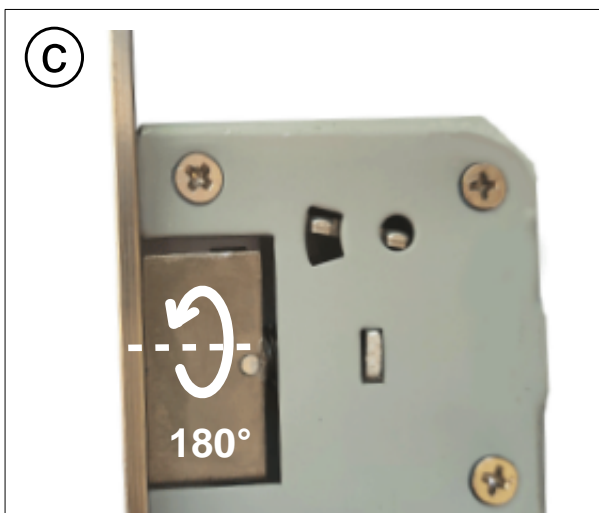
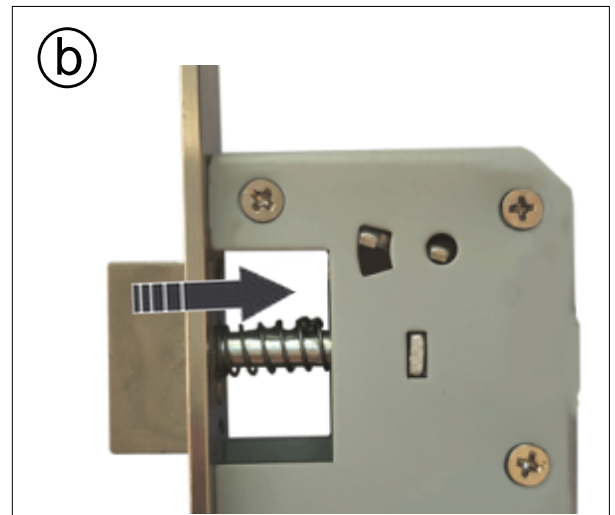
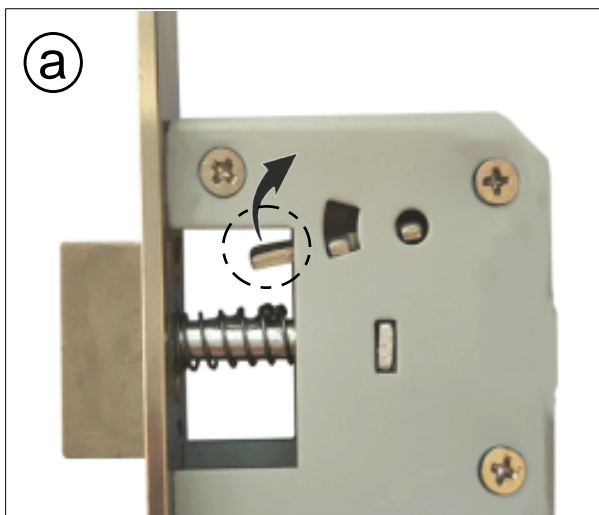
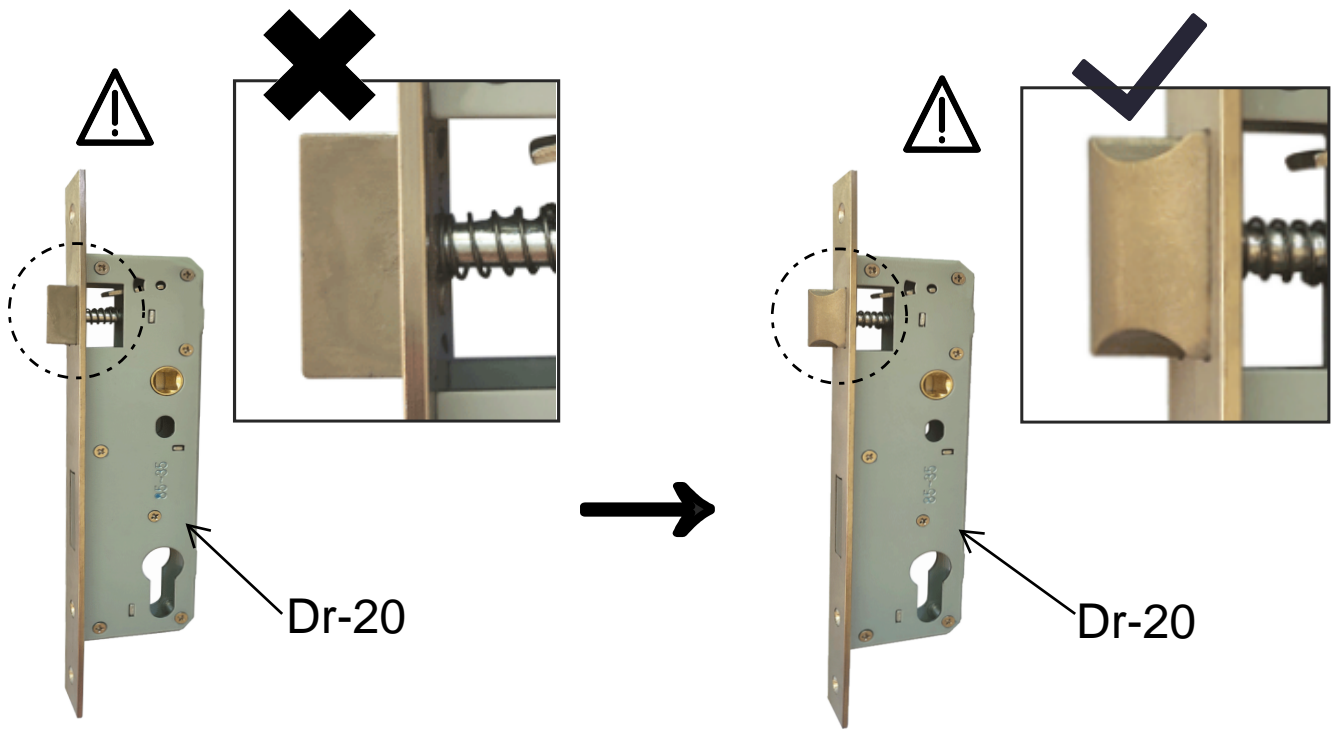

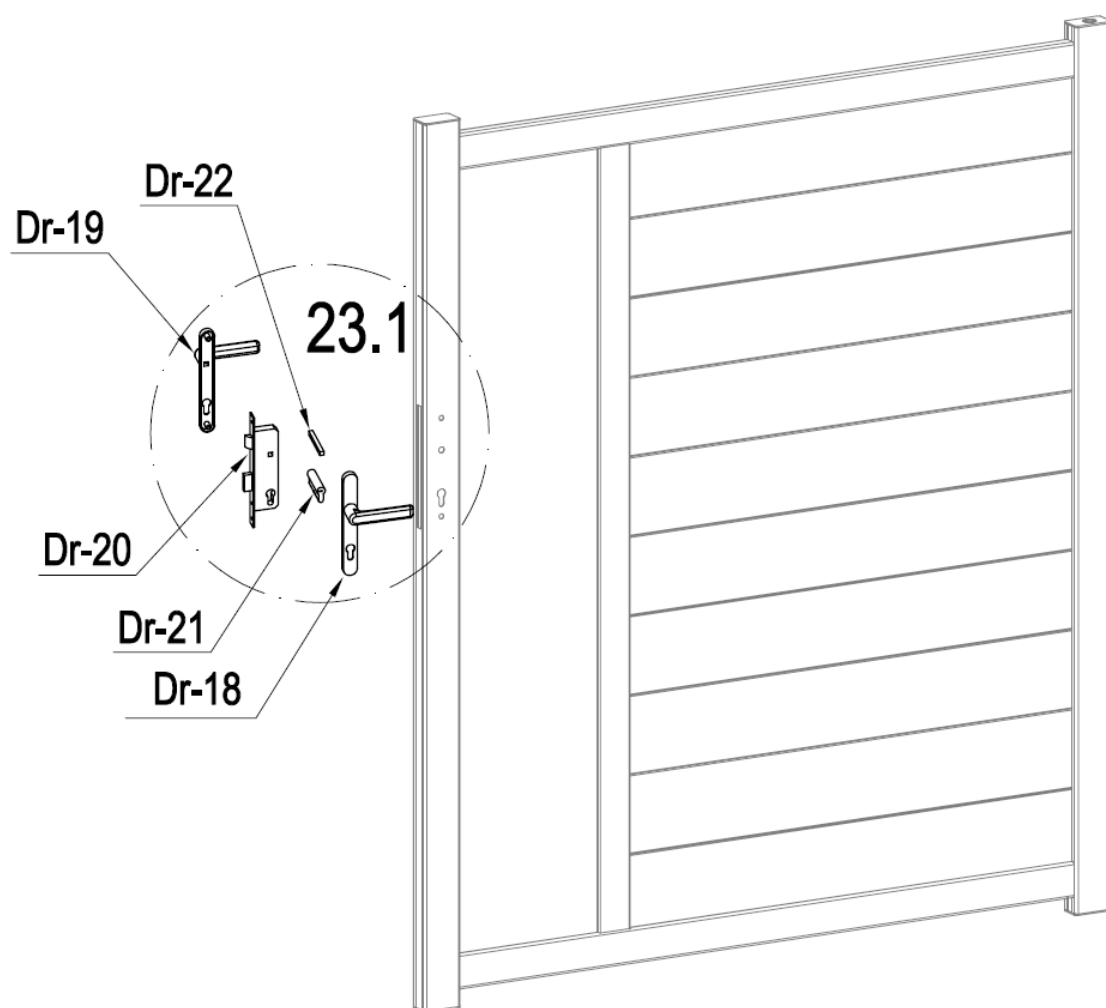

	Dr-20	1
	Dr-21	1

FR: Si vous n'installez pas l'ouvre-porte automatique, reportez-vous simplement aux étapes d'instructions suivantes. Si vous devez installer l'ouvre-porte automatique, n'installez pas les accessoires Dr-20 (corps de serrure) et Dr-21 (cylindre de serrure).

EN: if not to install the Automatic Gate Opener, just refer to following instruction steps. If need to install the Automatic Gate Opener, do not install accessory Dr-20(lock body) and Dr-21(lock cylinder).

DE: Wenn Sie den automatischen Toröffner nicht installieren möchten, befolgen Sie einfach die folgenden Anweisungen. Wenn der automatische Toröffner installiert werden muss, installieren Sie nicht die Zubehörteile Dr-20 (Schlosskörper) und Dr-21 (Schließzylinder).

ES: si no va a instalar el abrepuertas automático, simplemente consulte los siguientes pasos de instrucciones. Si necesita instalar el abrepuertas automático, no instale el accesorio Dr-20 (cuerpo de la cerradura) y Dr-21 (cilindro de la cerradura).

IT: se non per installare l'apricancello automatico, fare riferimento ai seguenti passaggi delle istruzioni. Se è necessario installare l'apricancello automatico, non installare l'accessorio Dr-20 (corpo serratura) e Dr-21 (cilindro serratura).

NL: als u de automatische poortopener niet wilt installeren, raadpleeg dan de volgende instructies. Als u de automatische poortopener moet installeren, installeer dan geen accessoire Dr-20 (slotlichaam) en Dr-21 (slotcilinder).

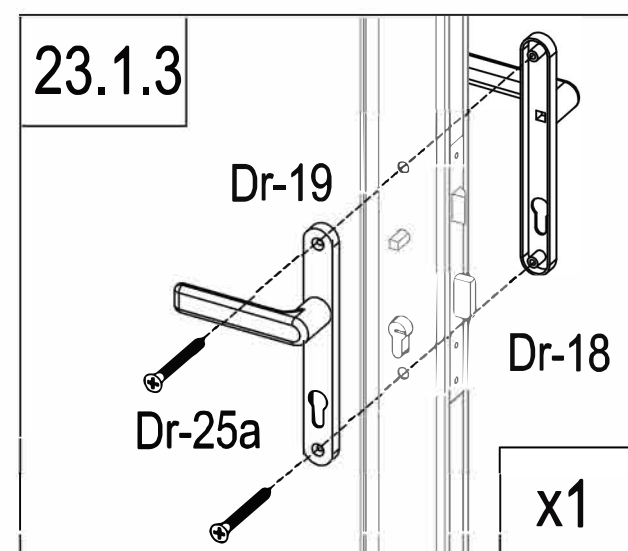
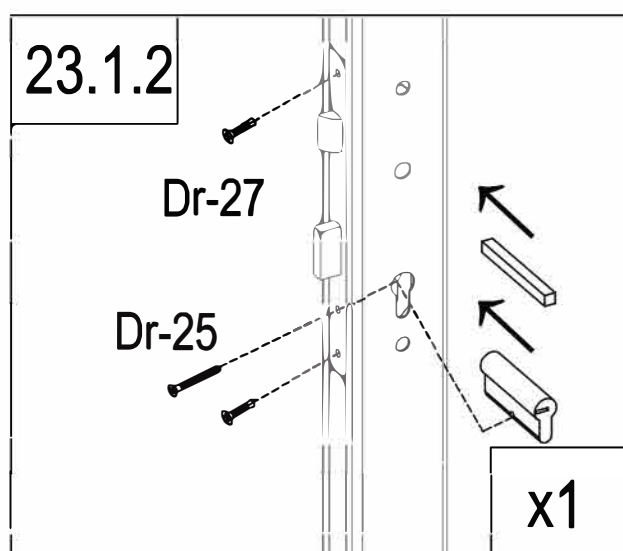
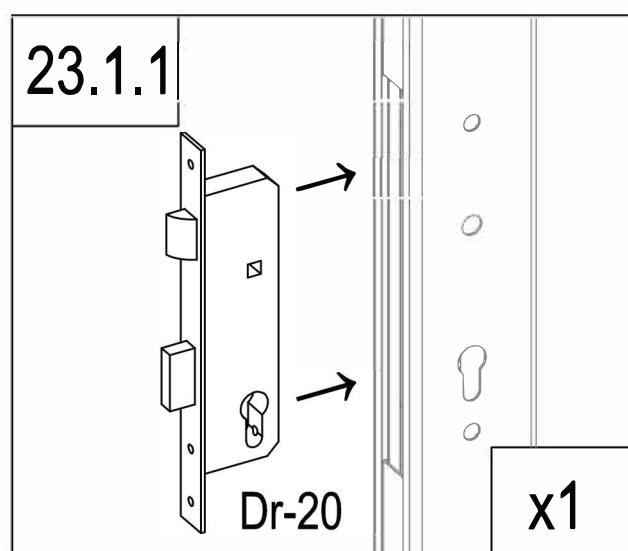

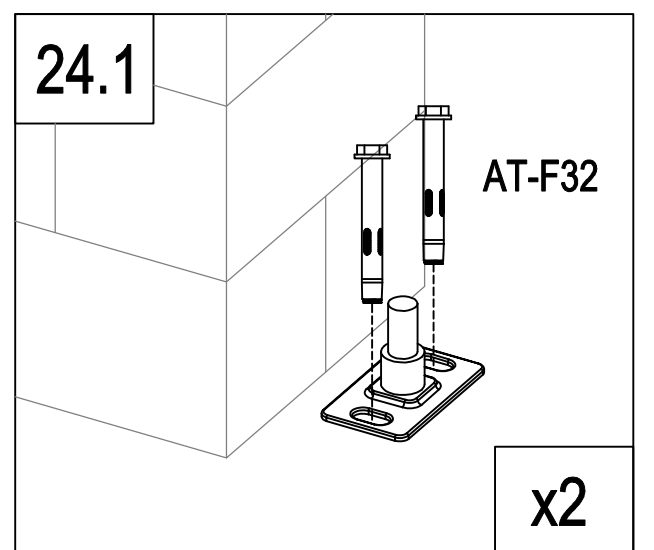
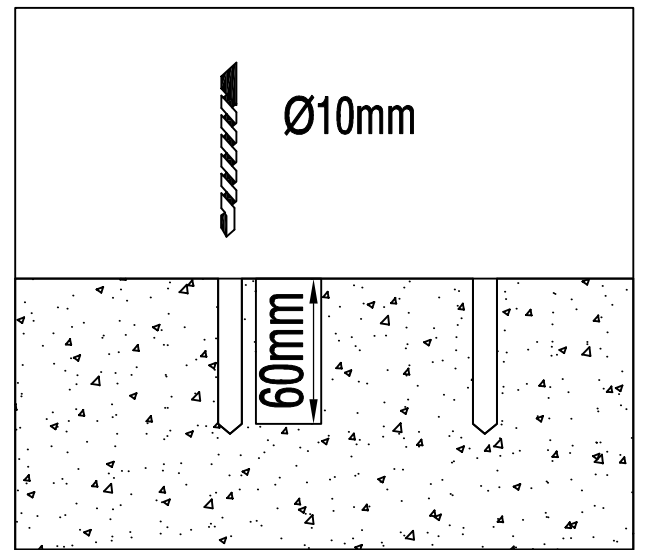
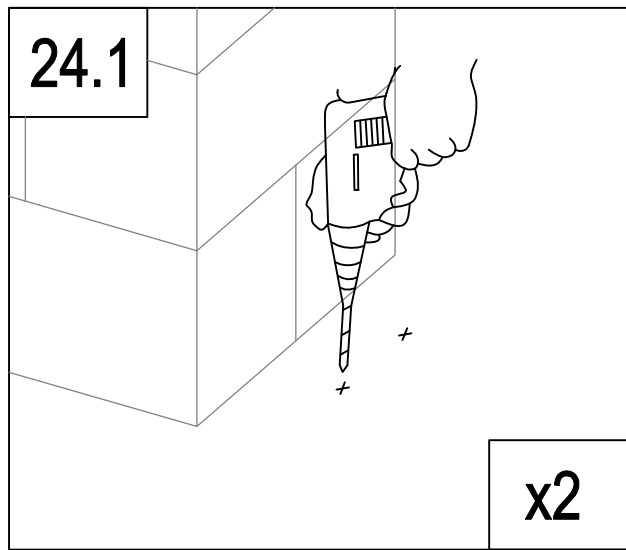
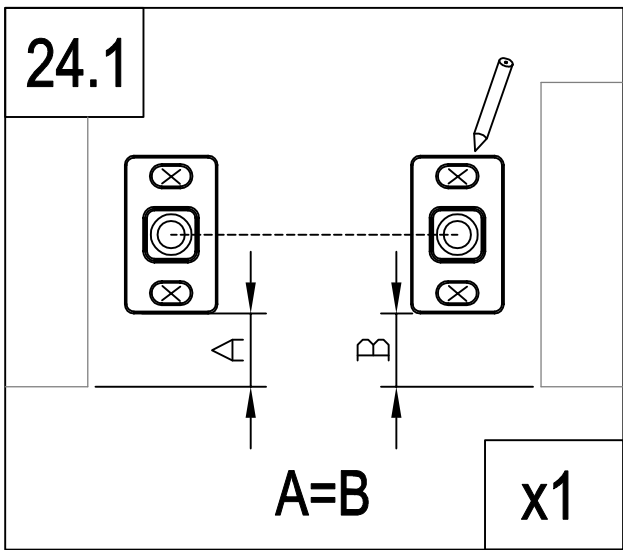
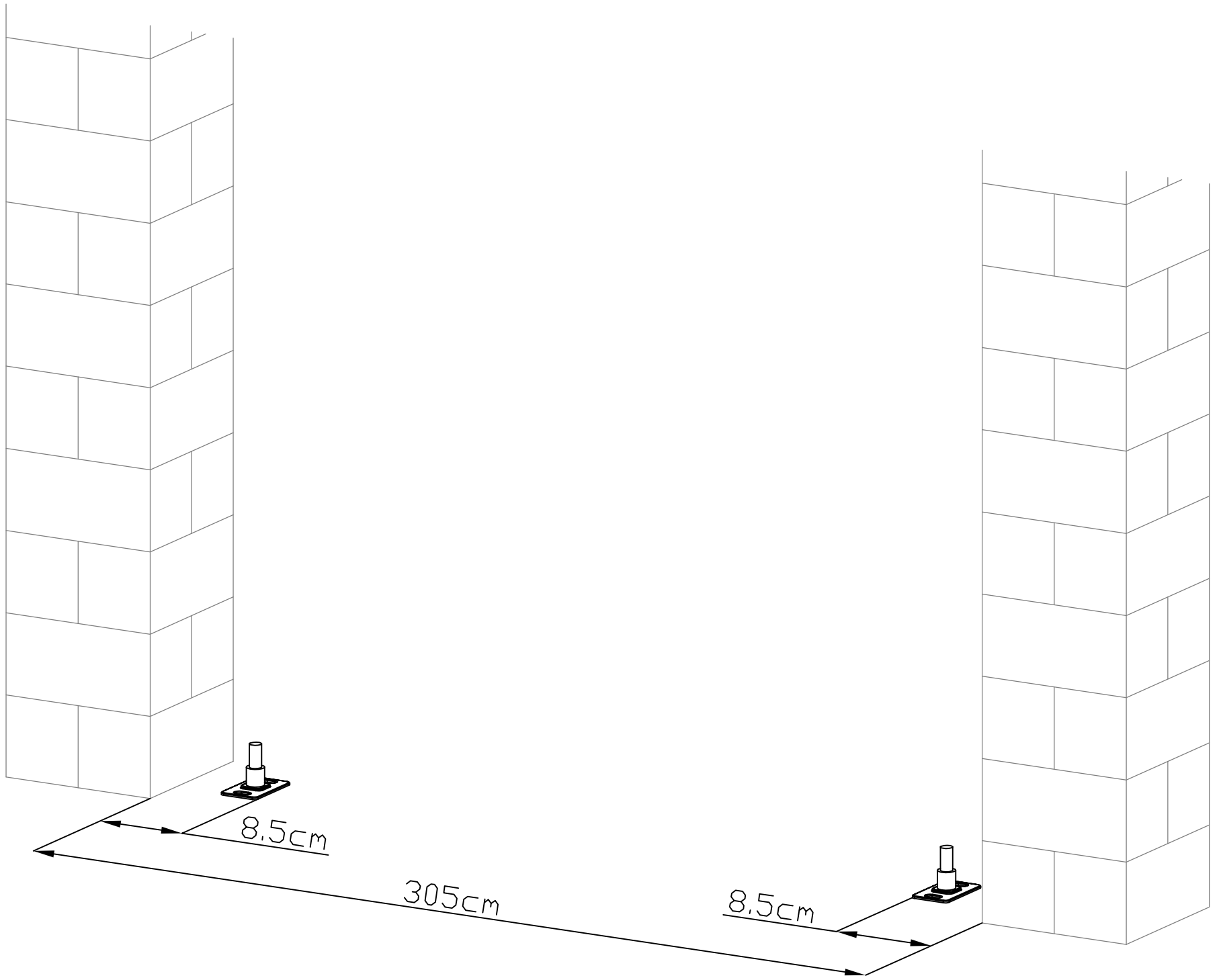

	Dr-20	1
	Dr-21	1
	Dr-22	1
	Dr-25	1

	Dr-18	1
	Dr-19	1
	Dr-25a	2
	Dr-27	2



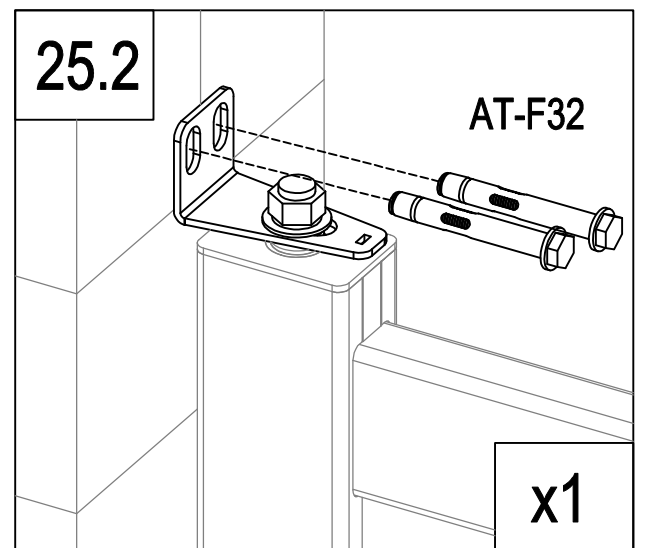
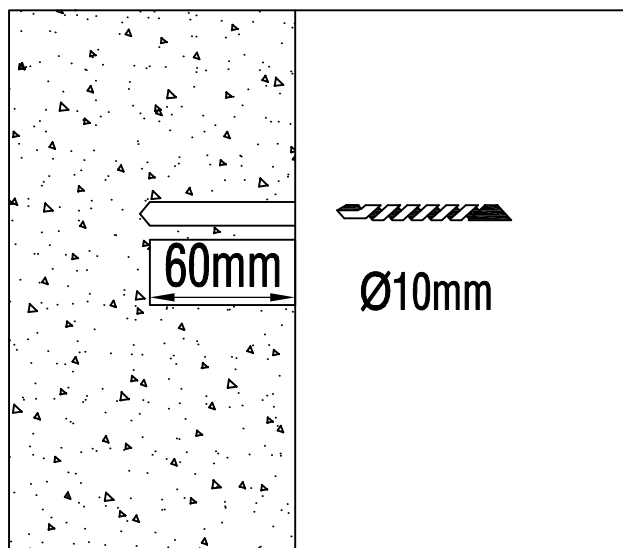
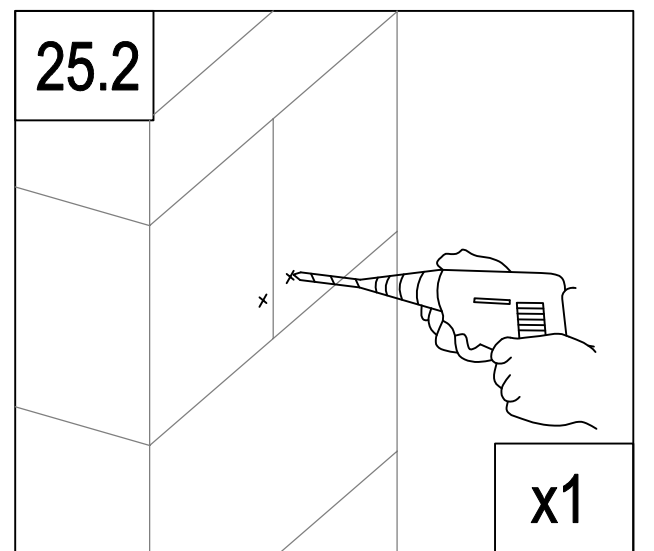
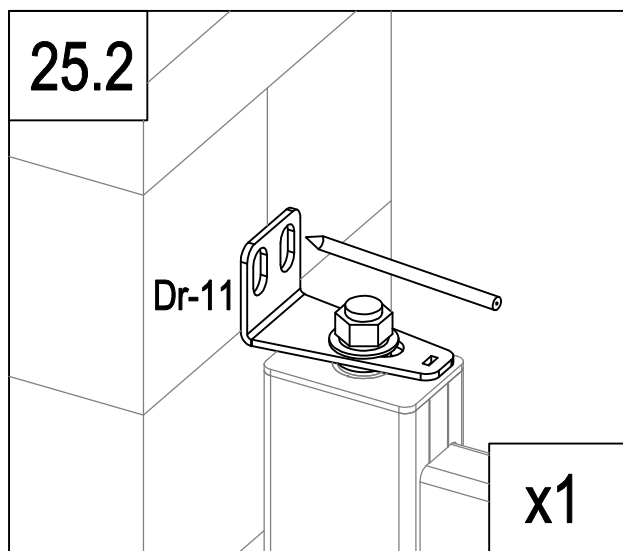
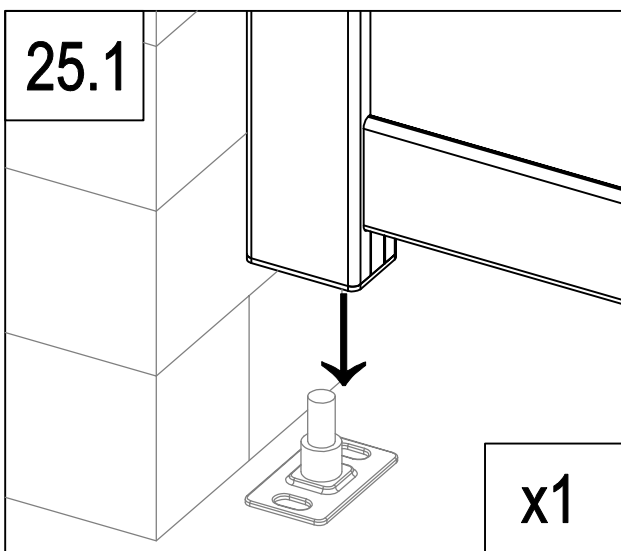
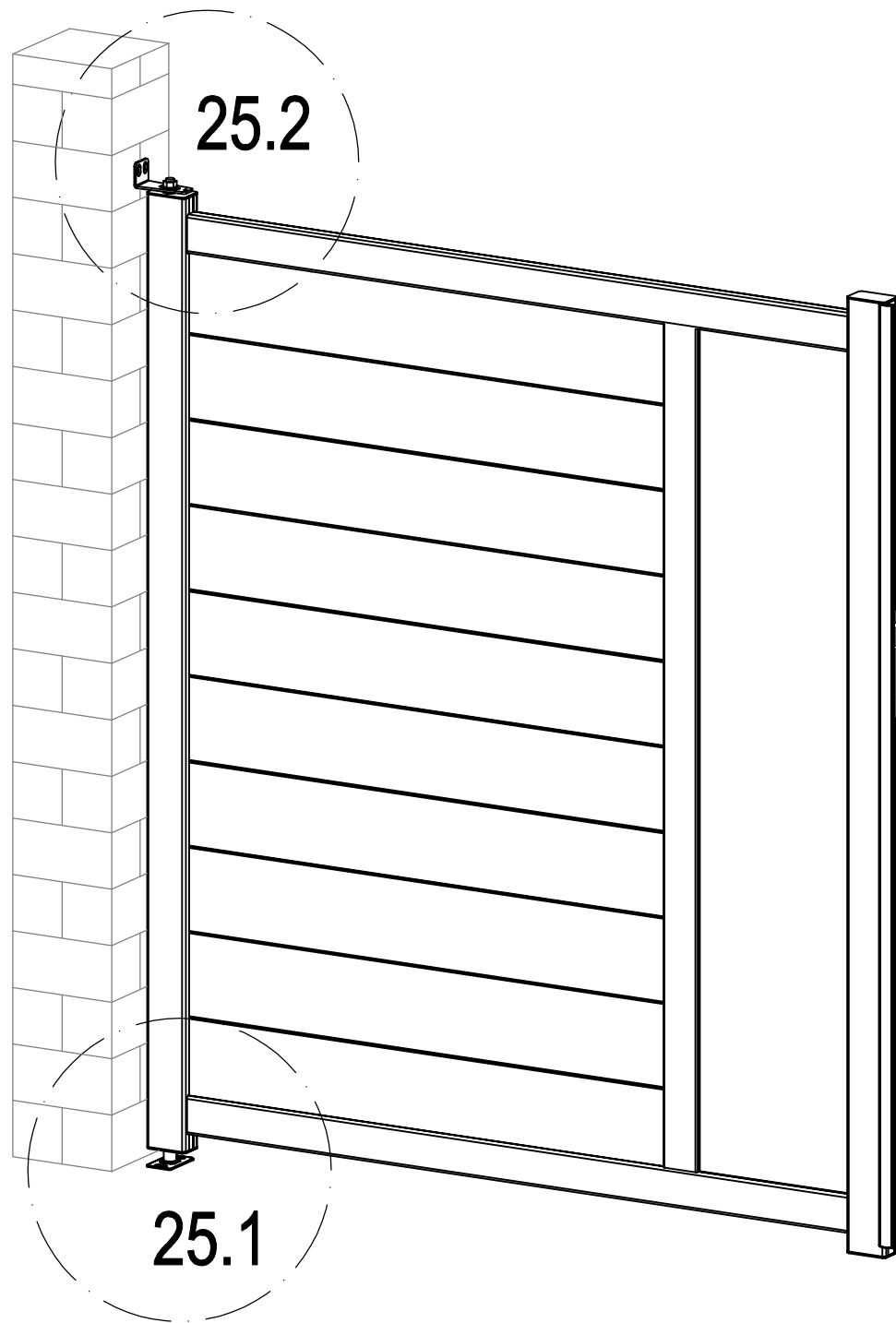

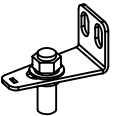
	Dr-12	2
	AT-F32	4



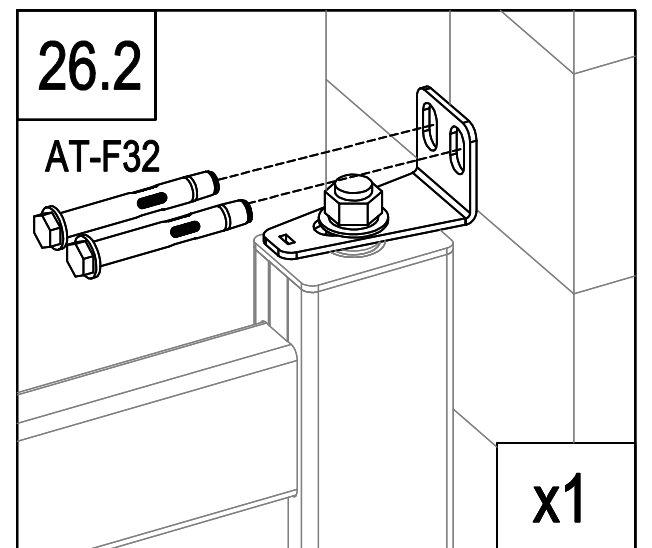
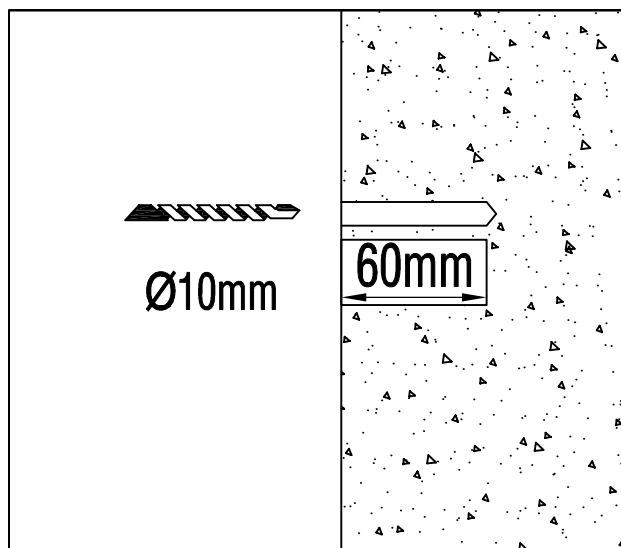
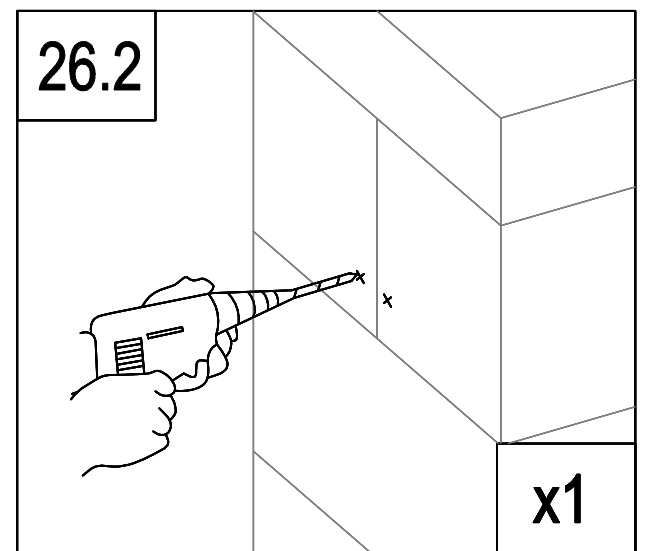
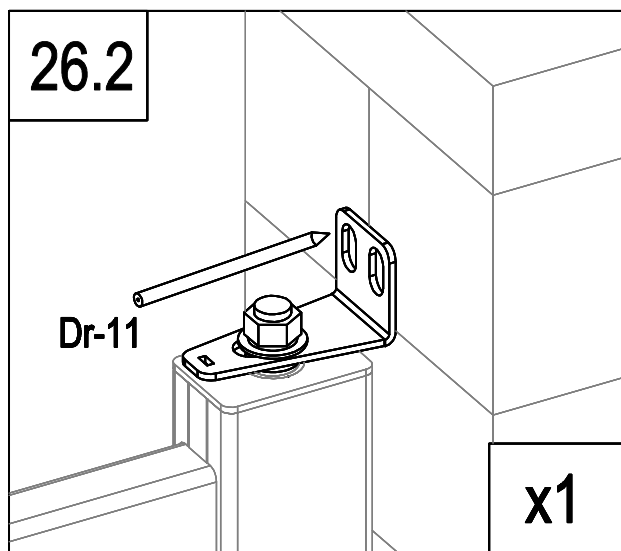
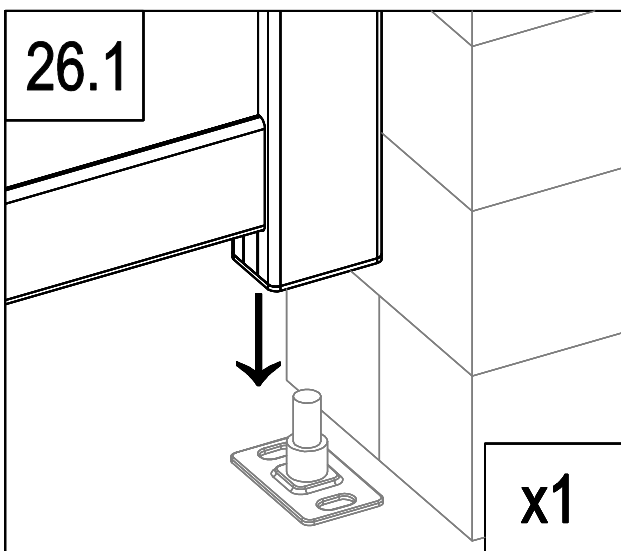
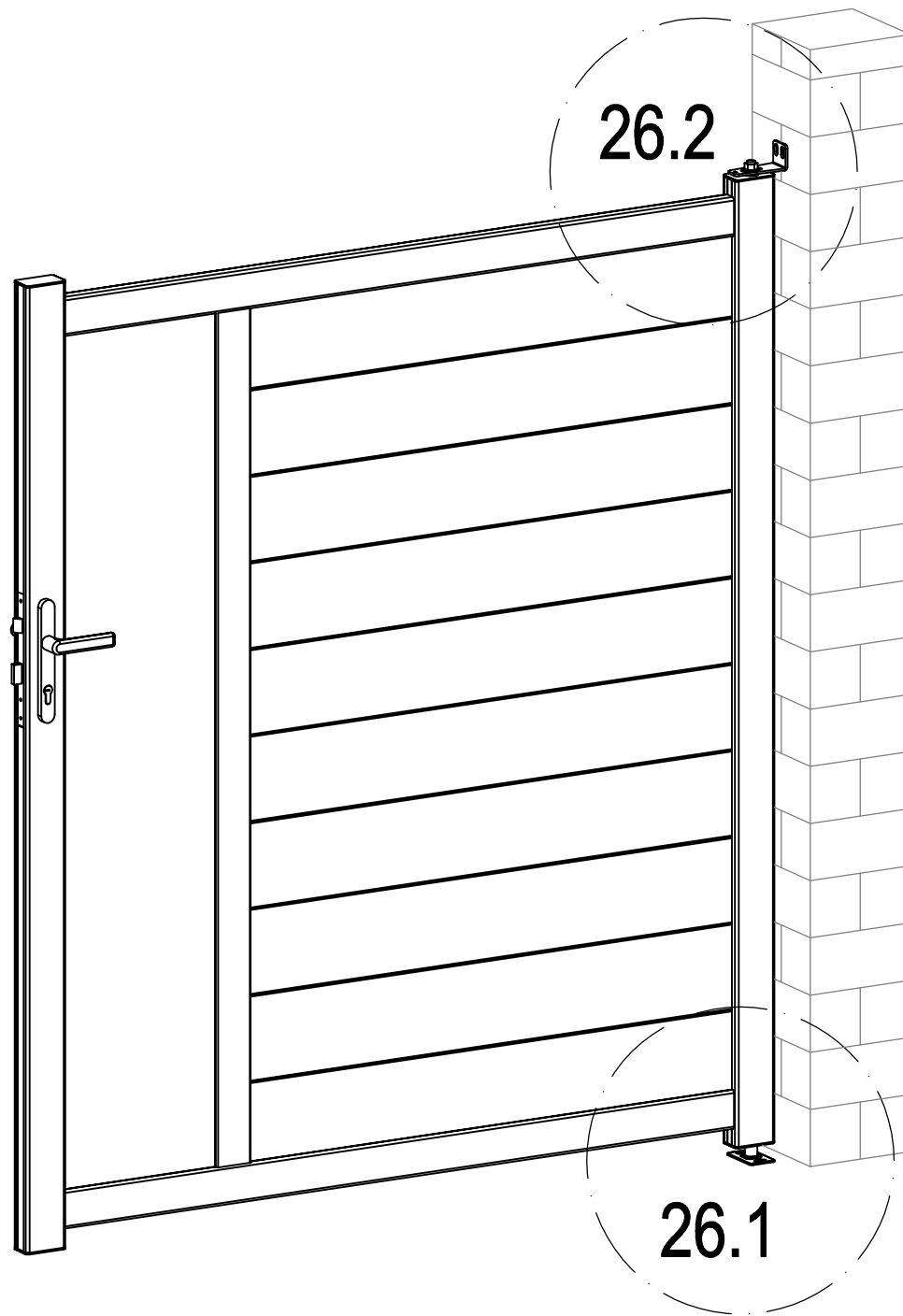

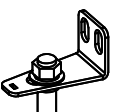
	Dr-11	1
	AT-F32	2

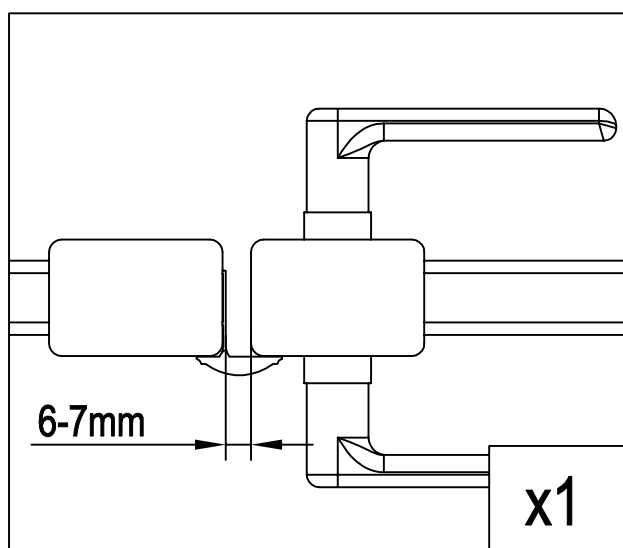
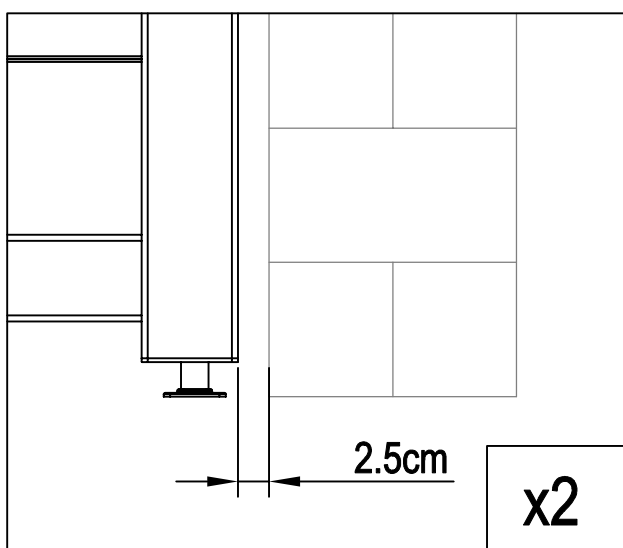
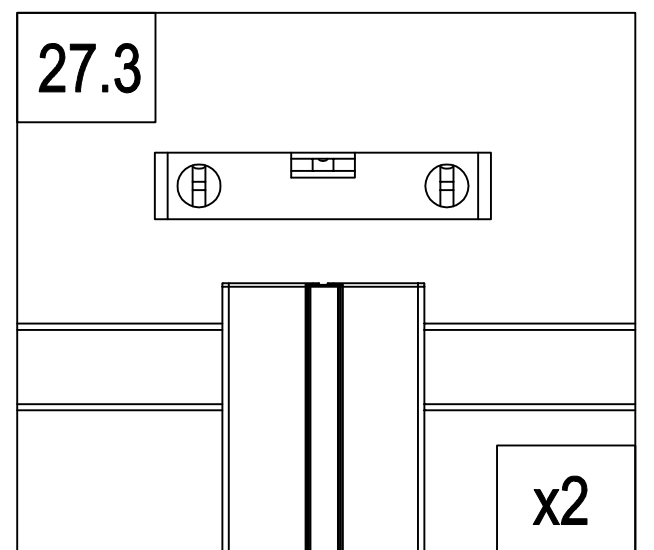
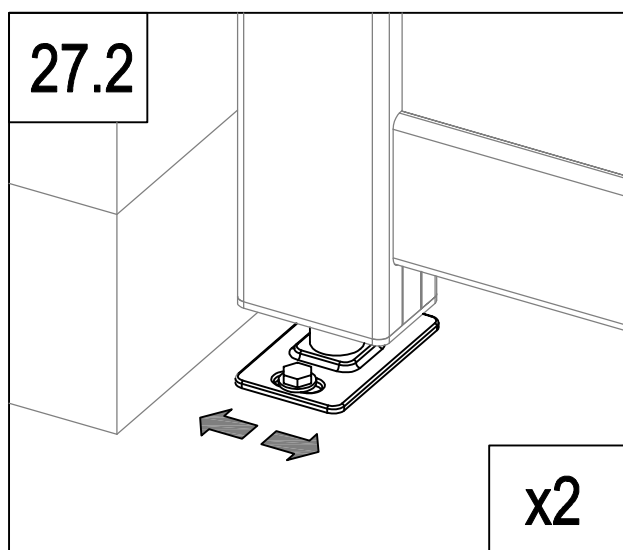
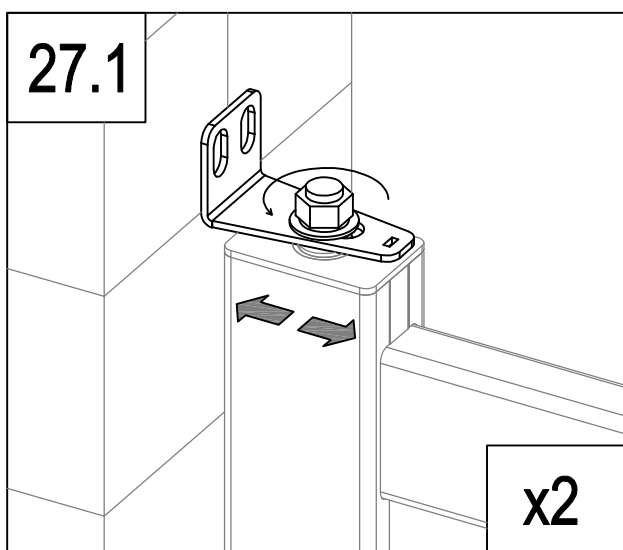
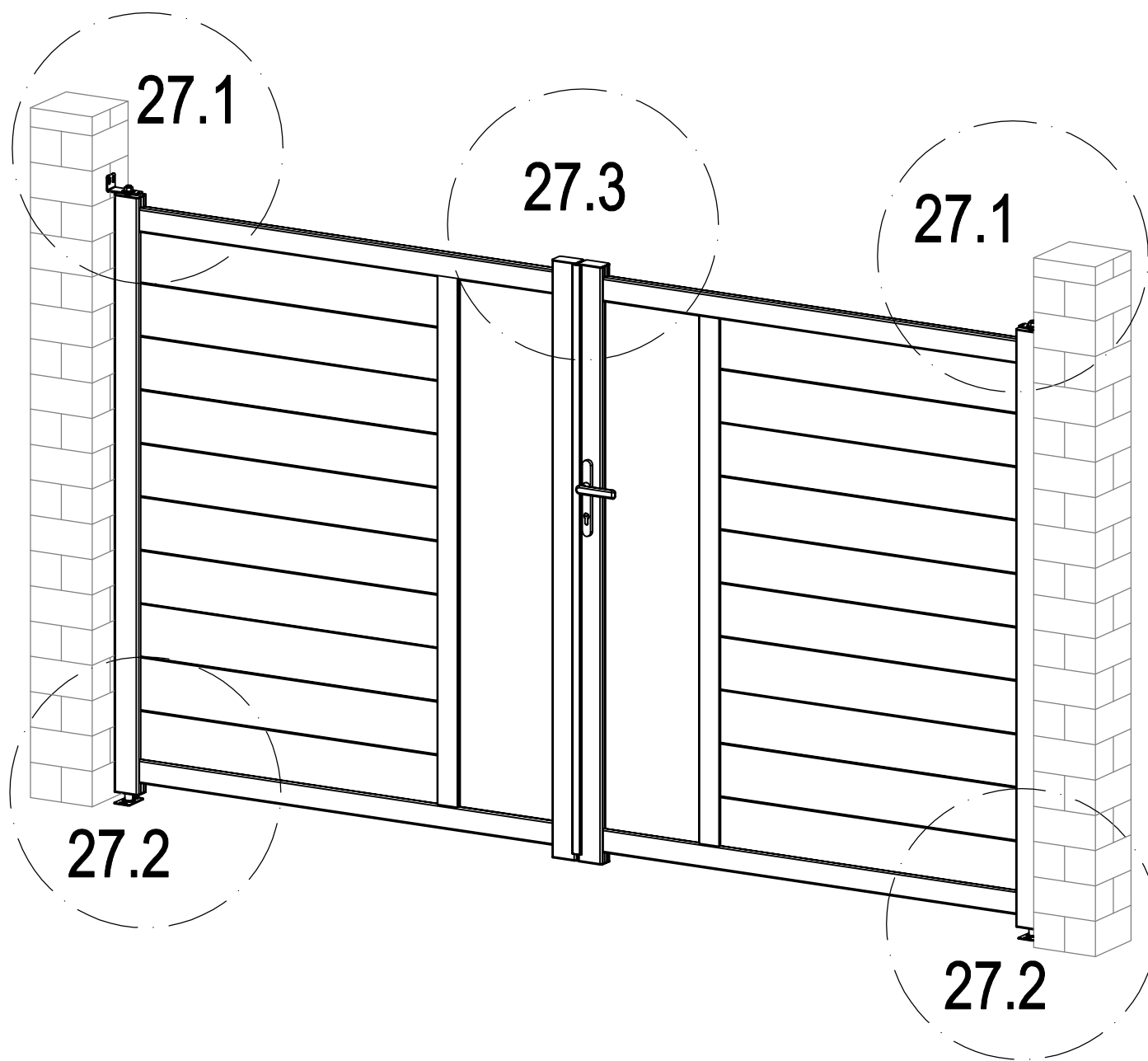

	Dr-11	1
	AT-F32	2

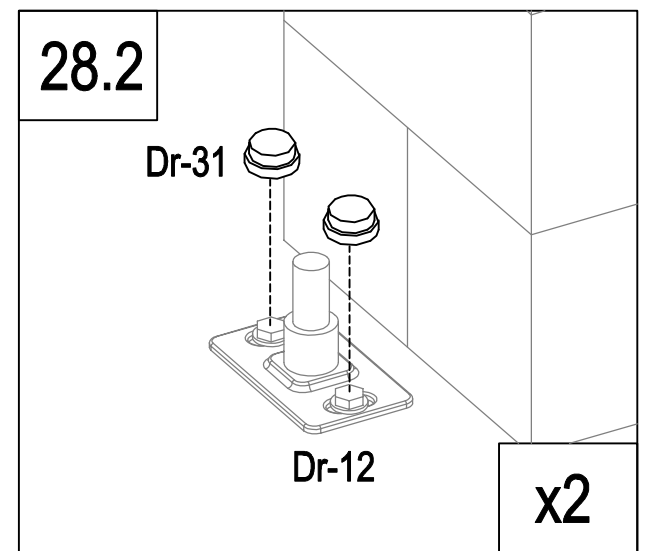
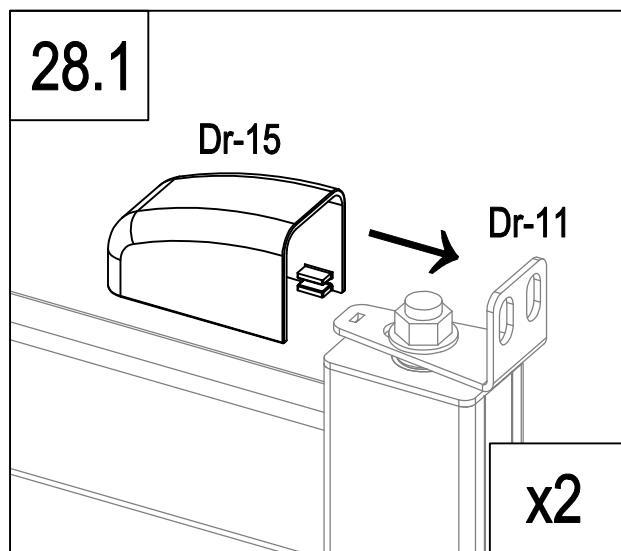
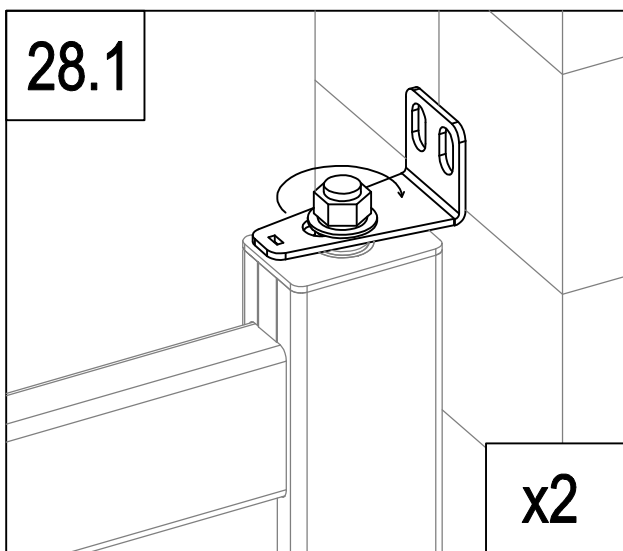
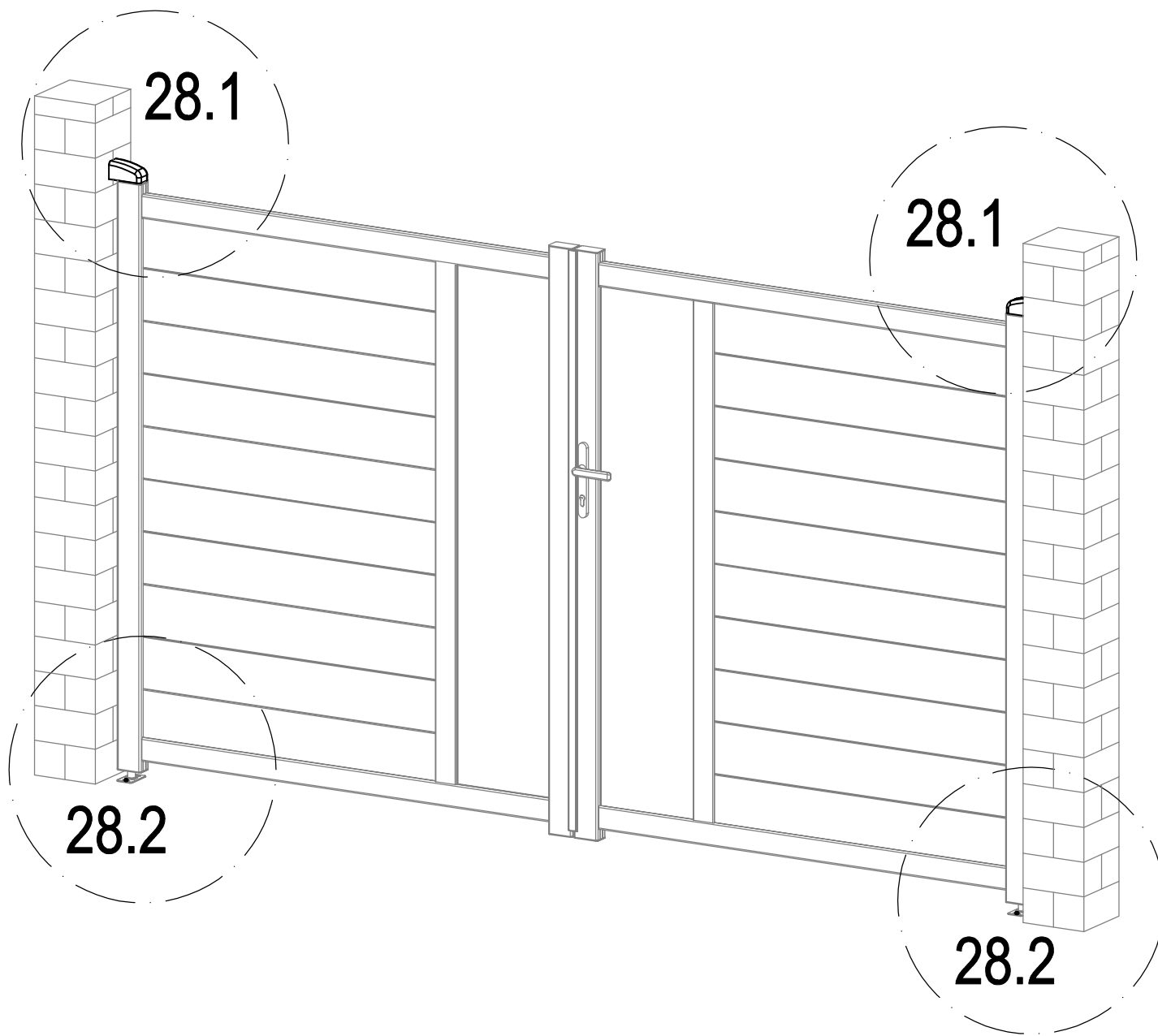

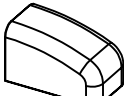

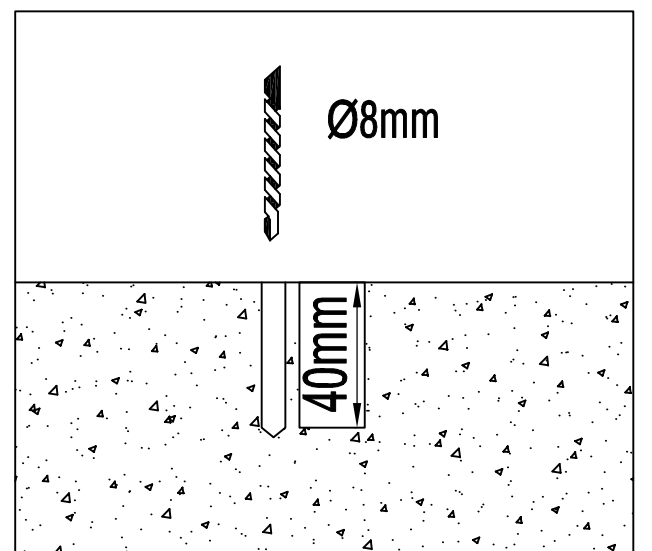
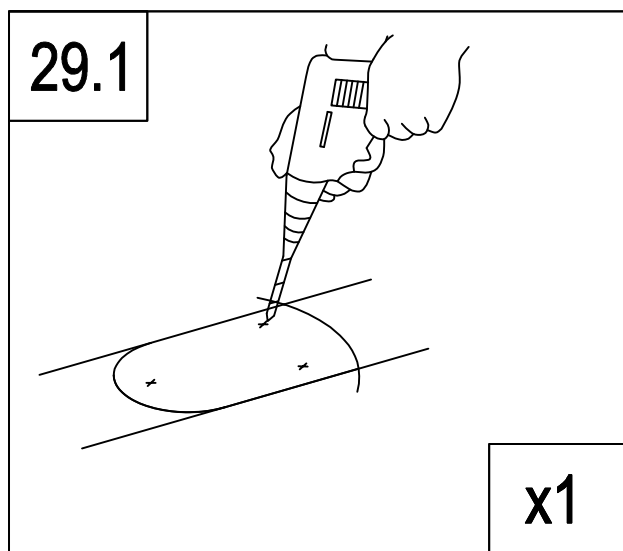
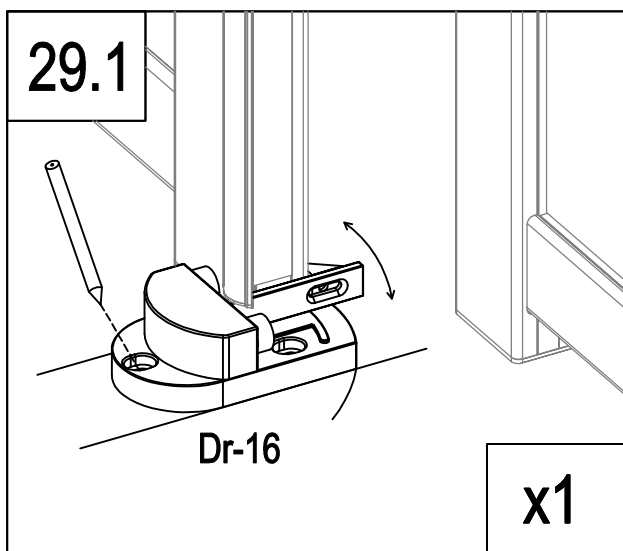
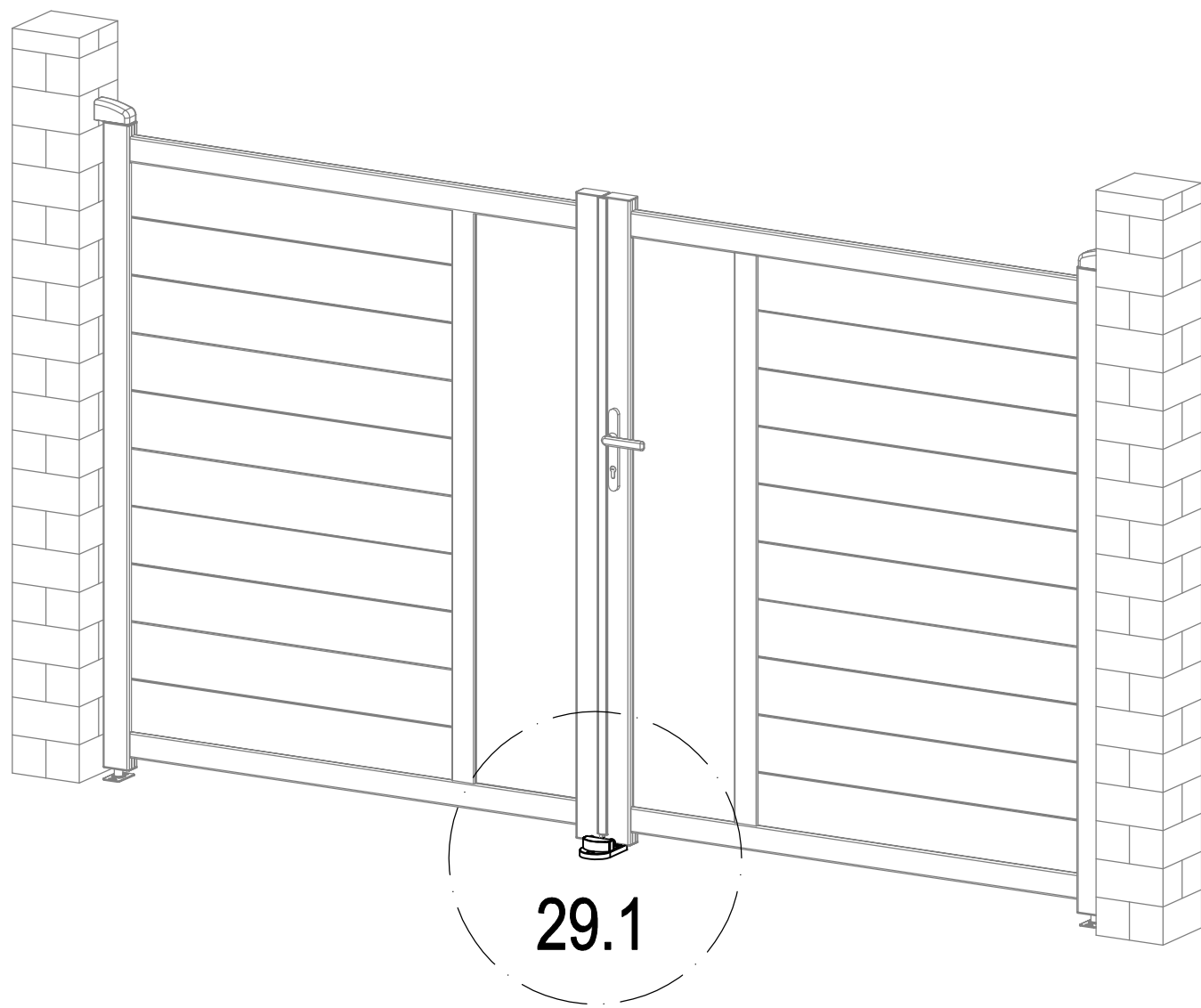

	Dr-15	2
	Dr-31	4

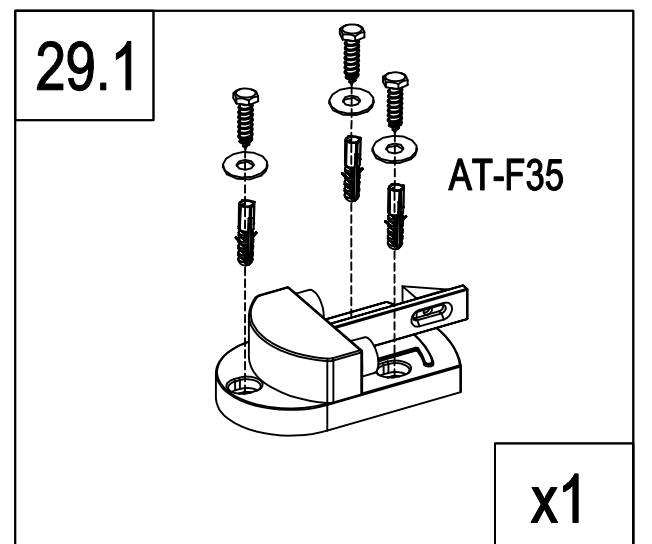

	Dr-16	1
	AT-F34	3
	AT-F35	3

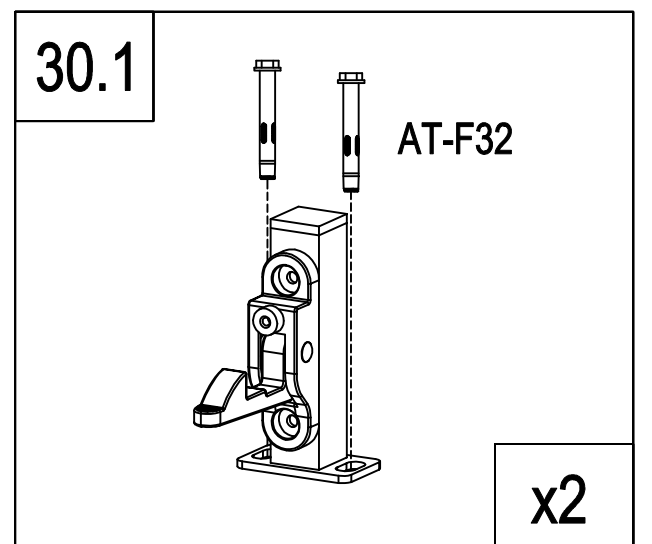
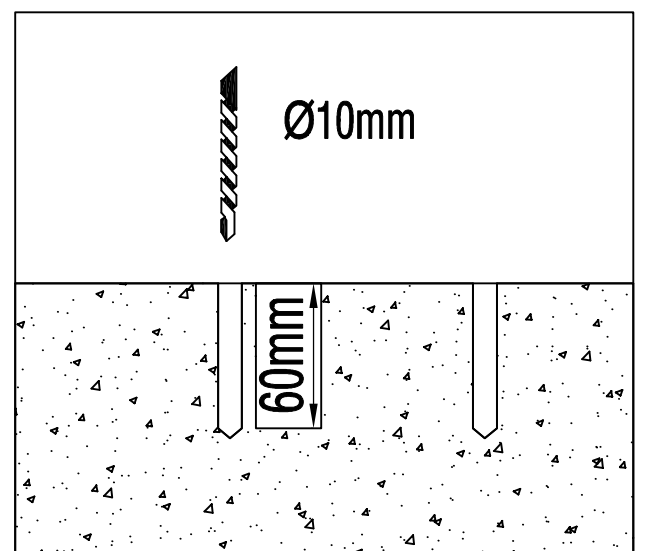
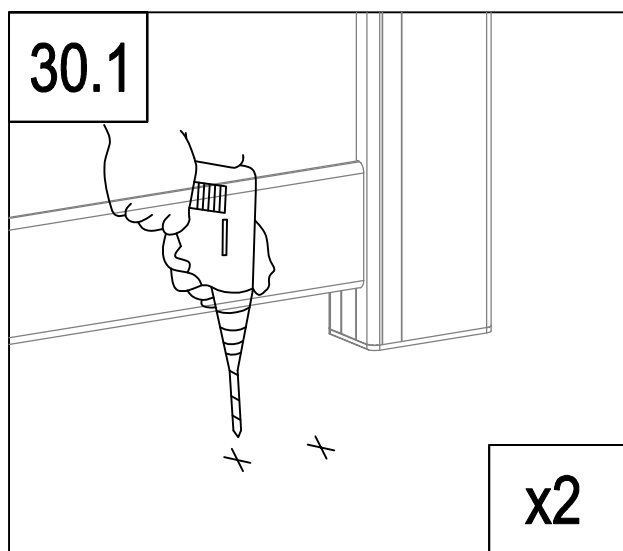
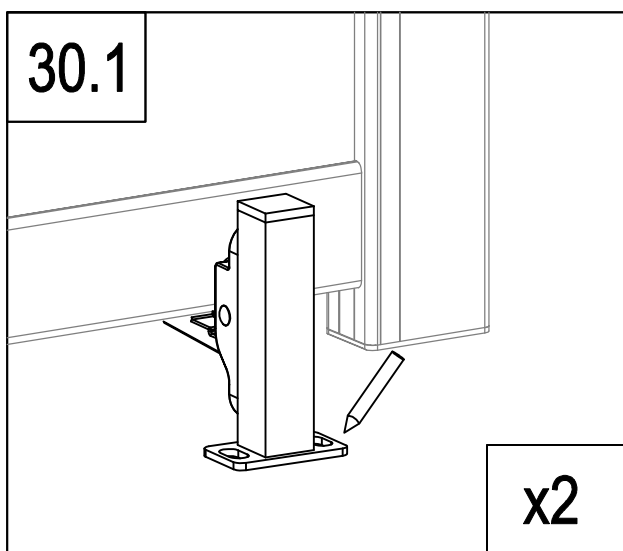
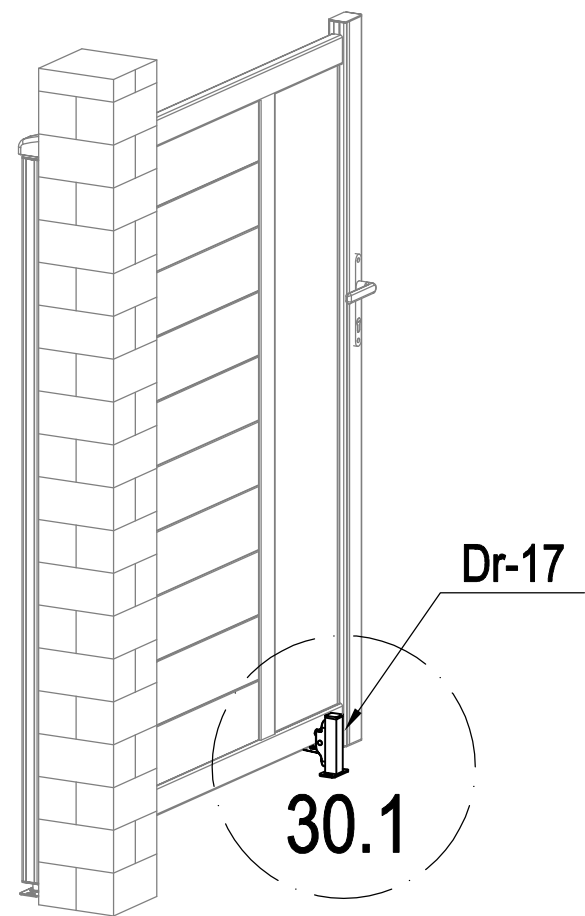
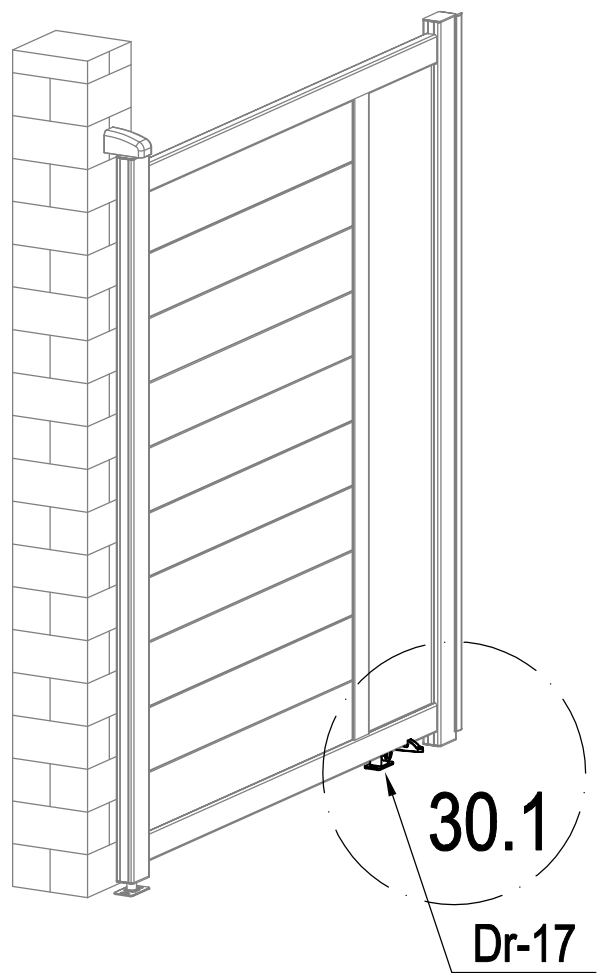



	AT-F32	4
	Dr-17	2

FR: Zone d'automatisation appropriée sur la carte renforcée

EN: Suitable Automation Area on the Reinforced Board

DE: Geeigneter Automatisierungsbereich auf der verstärkten Platine

ES: Área de automatización adecuada en el tablero reforzado

IT: Area di automazione adatta sul pannello rinforzato

NL: Geschikt automatiseringsgebied op de versterkte plaat

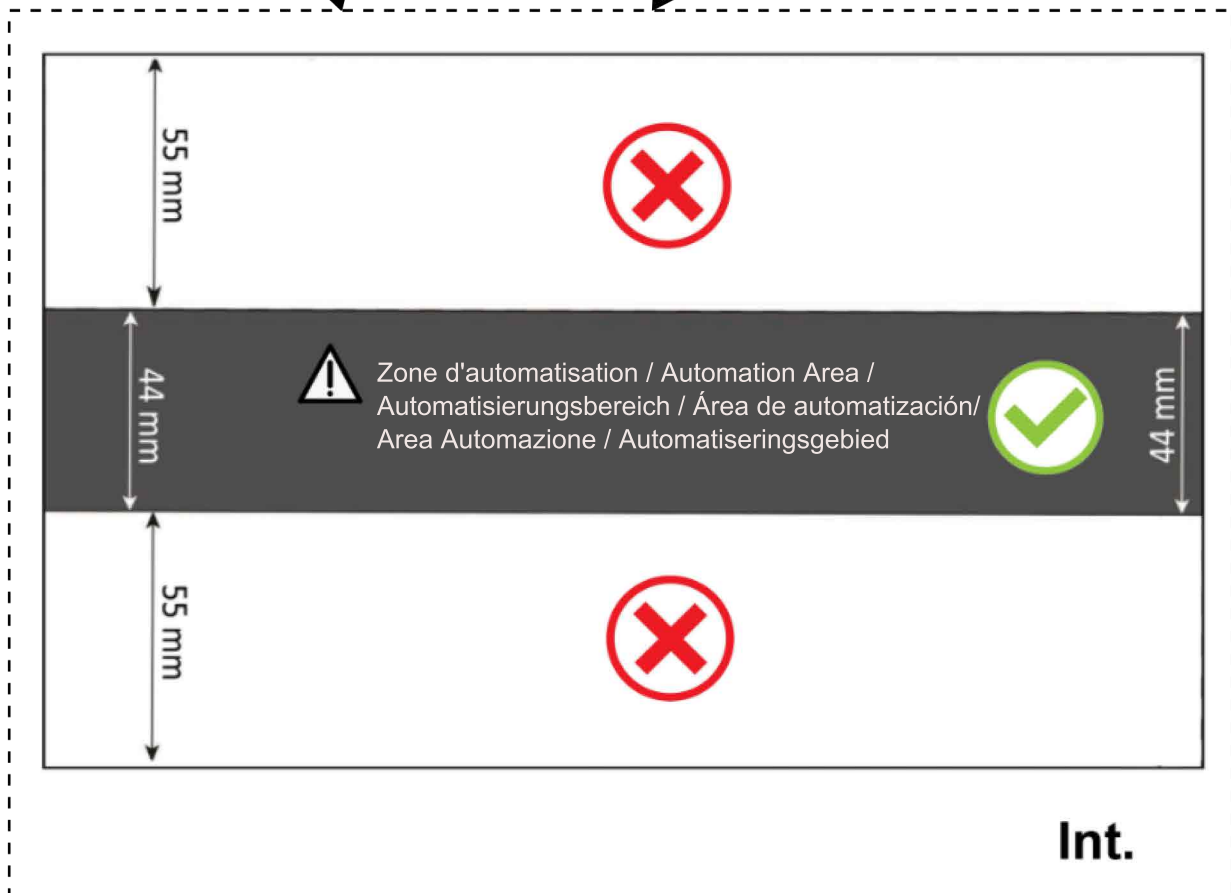
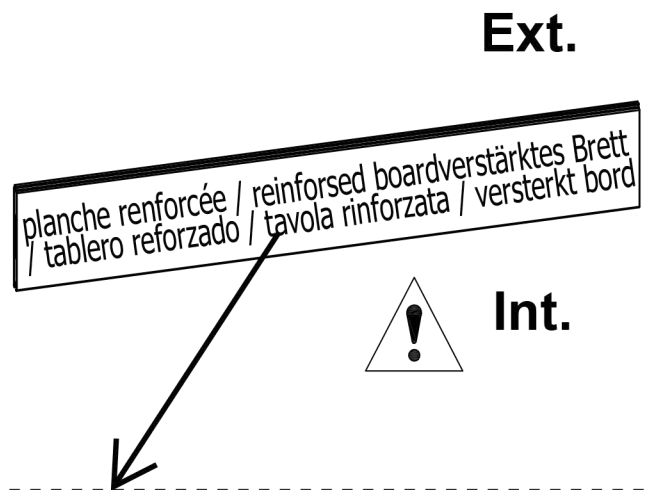
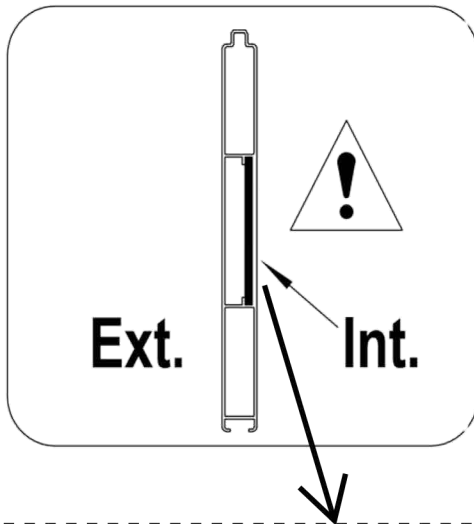



VS-Nov-2021

Imported by - Importé par
VENTE-UNIQUE.COM
9 Rue Jacquart 93310 Le Pré-Saint-Gervais
Made in China/ Fabriqué en Chine