

Manuel d'instructions/Instruction Manual/Bedienungsanleitung/  
Manual de instrucciones/Manuale di istruzioni/Handleiding/  
Manual de instruções/Instrukcja obsługi

# GREGOR

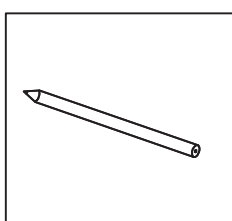

Porte en aluminium  
Art C-D + raindrop C2

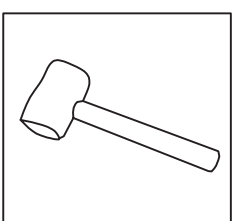
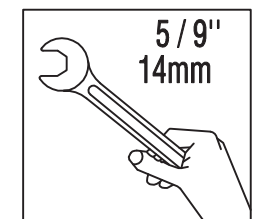
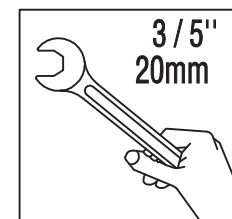
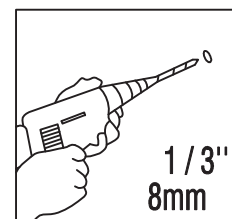
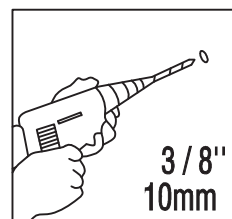
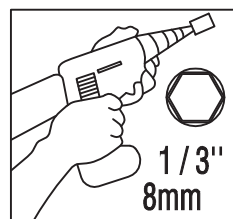
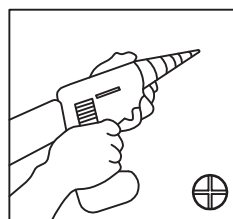
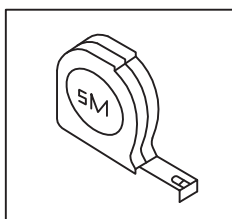
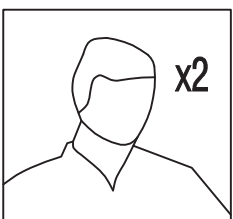
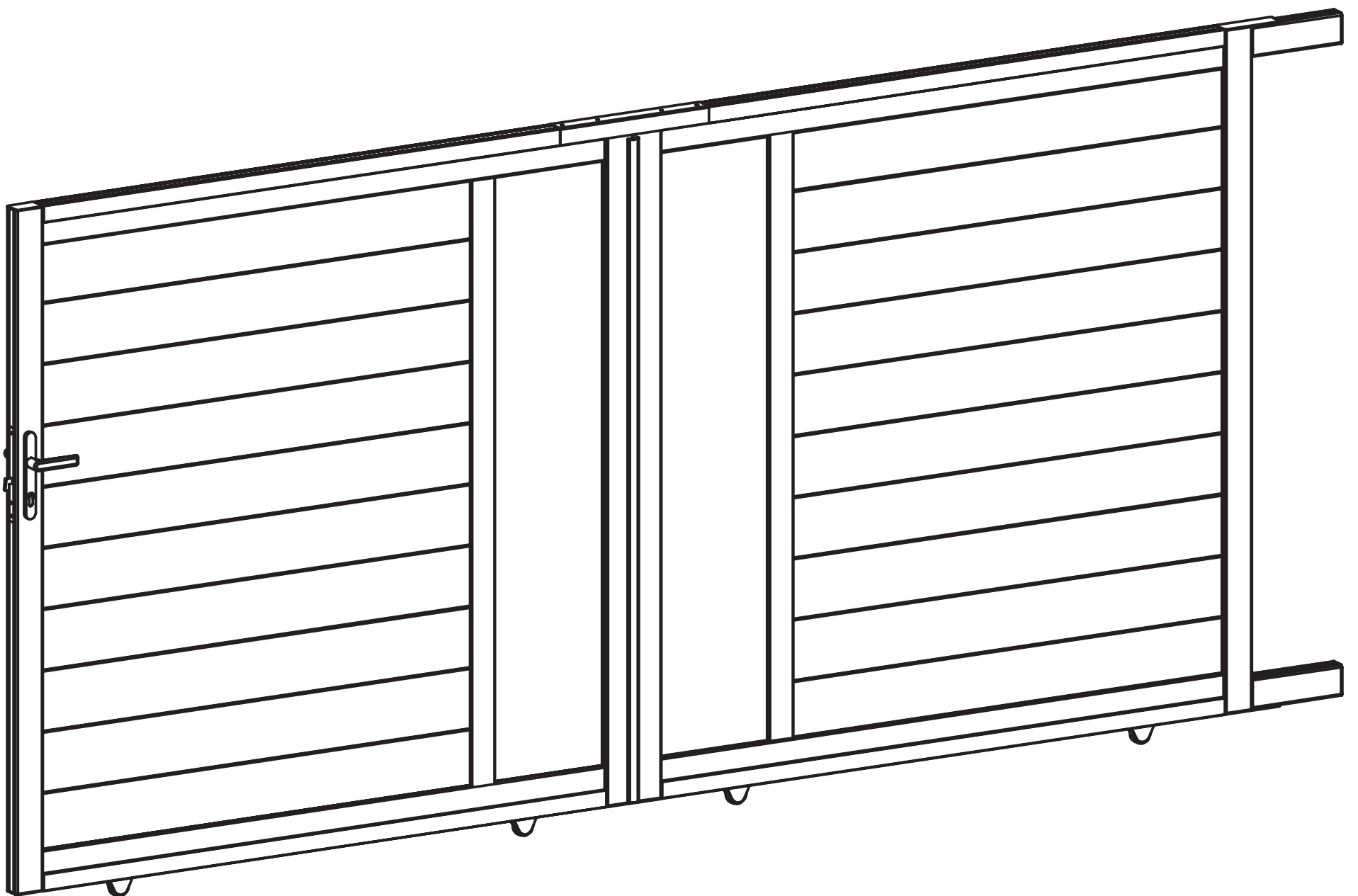

**! AVERTISSEMENT: nécessite un entretien rapide pour s'assurer que la construction est solide.**

**! WARNING: Need timely maintenance to make sure construction is strong.**

**! WARNUNG: Sie müssen rechtzeitig gewartet werden, um sicherzustellen, dass die Konstruktion stark ist.**

**! ADVERTENCIA: Necesita un mantenimiento oportuno para asegurarse de que la construcción sea sólida.**

**! AVVERTENZA: è necessaria una manutenzione tempestiva per assicurarsi che la costruzione sia robusta.**

**! WAARSCHUWING: Heeft tijdig onderhoud nodig om ervoor te zorgen dat de constructie sterk is.**

**! AVISO: Precisa de manutenção oportuna para garantir que a construção seja forte.**

**! OSTRZEŻENIE: Potrzebujesz terminowej konserwacji, aby upewnić się, że konstrukcja jest silna.**

**Ext.**

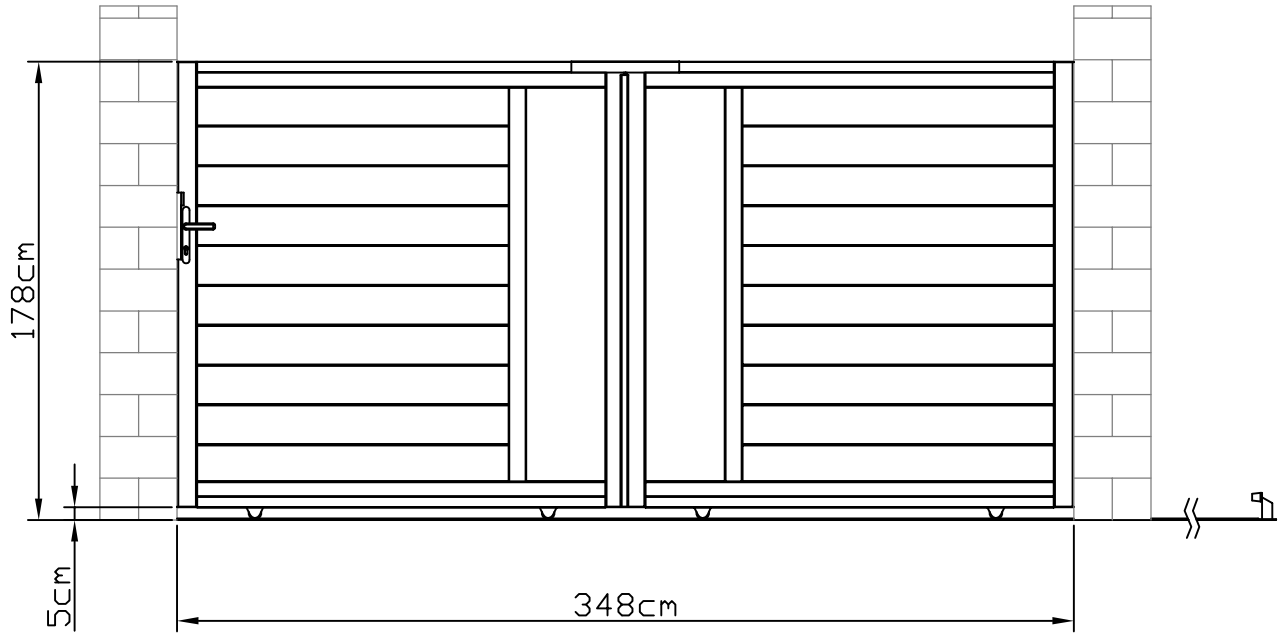

**Int.**

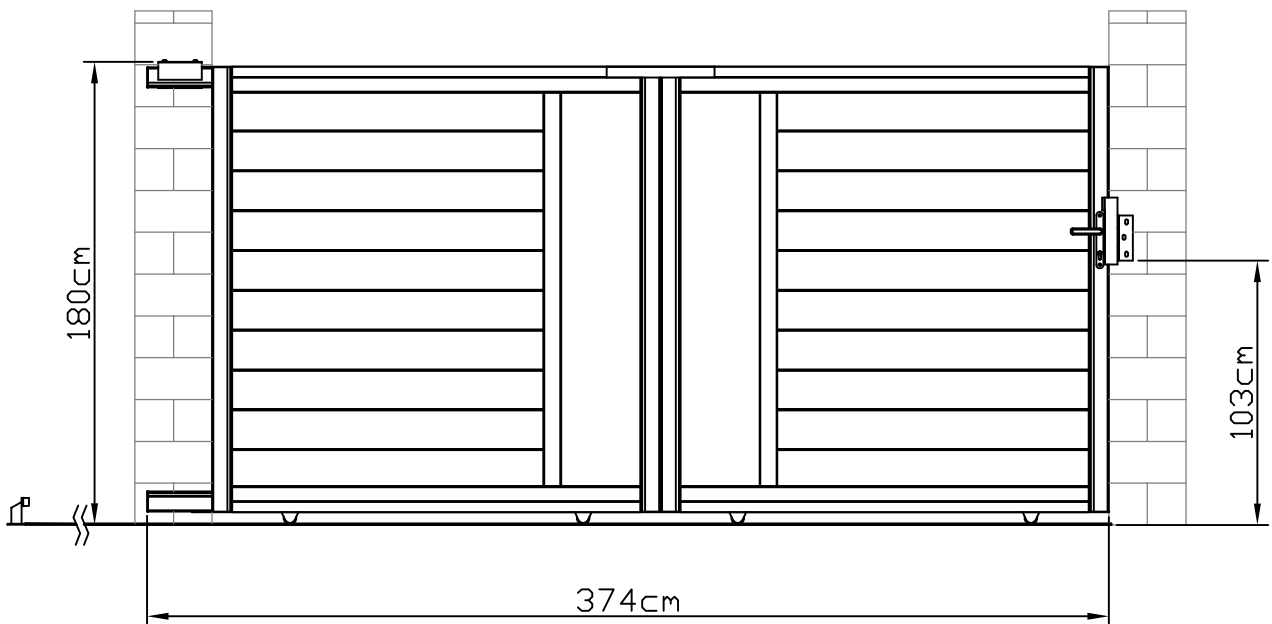

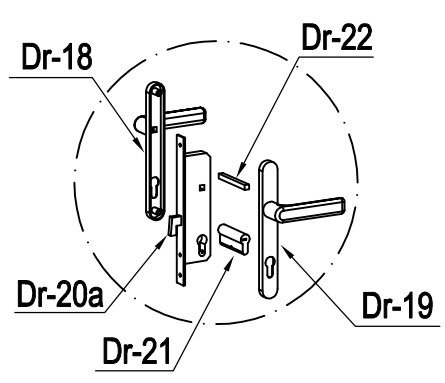
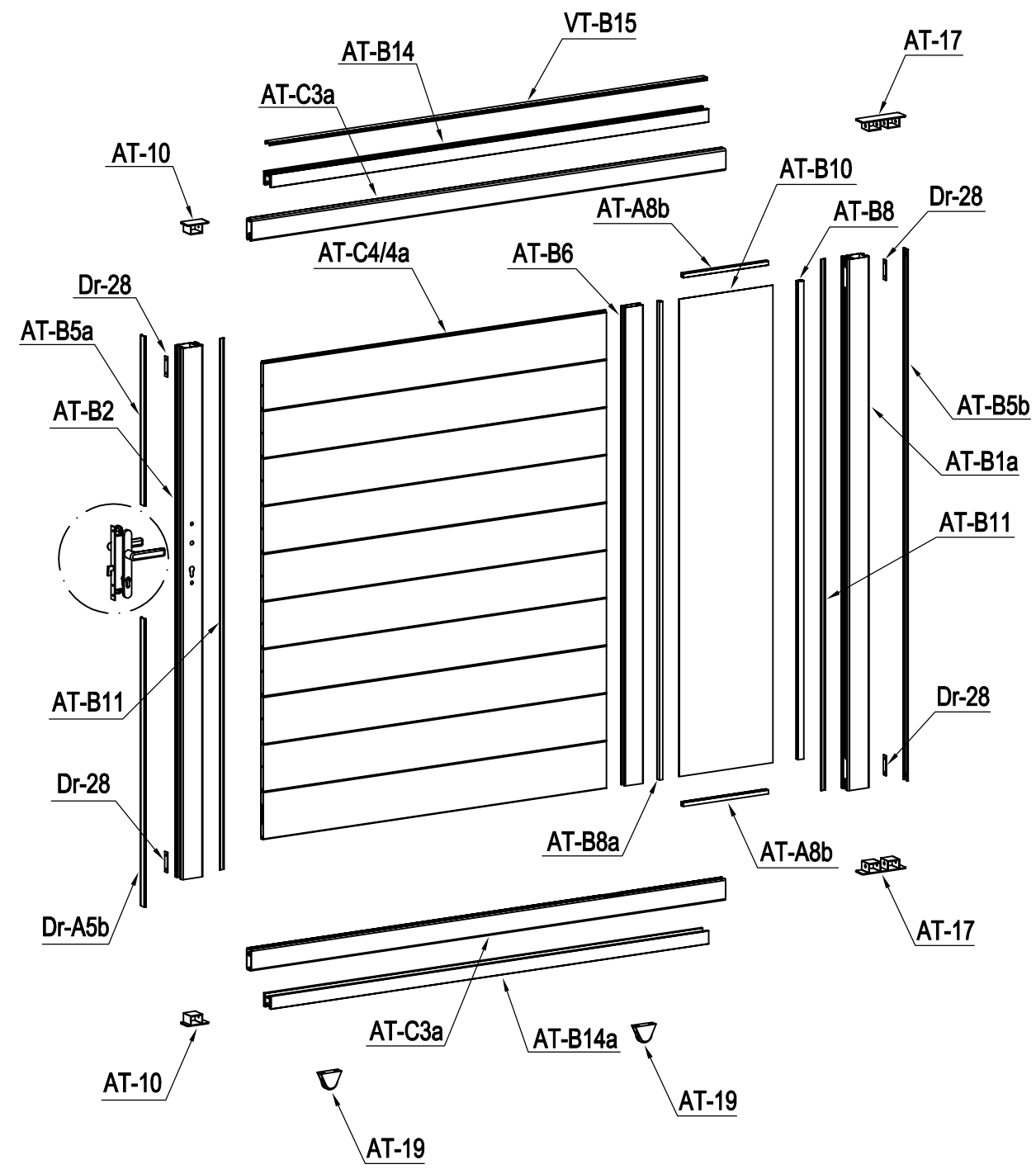

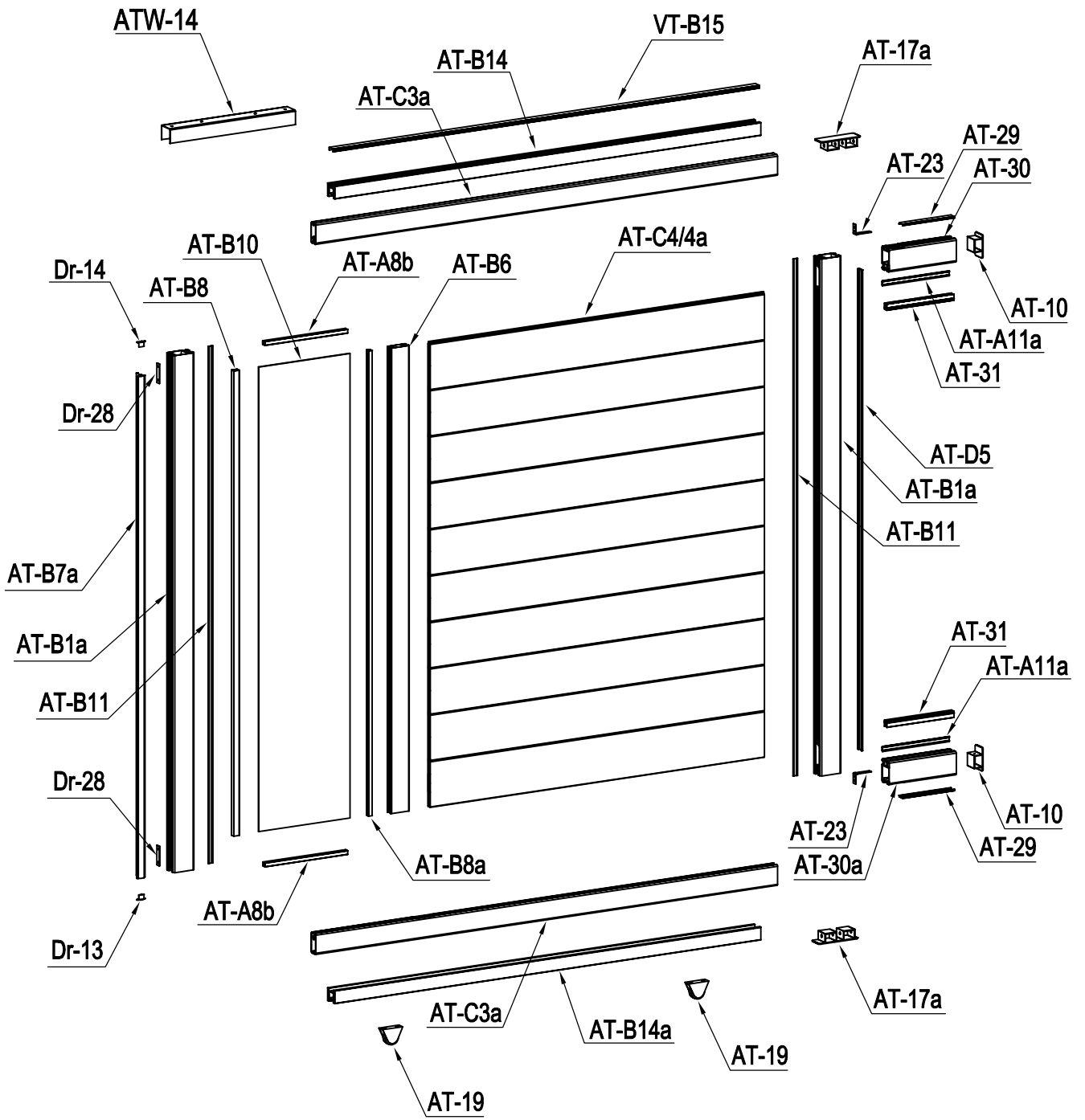

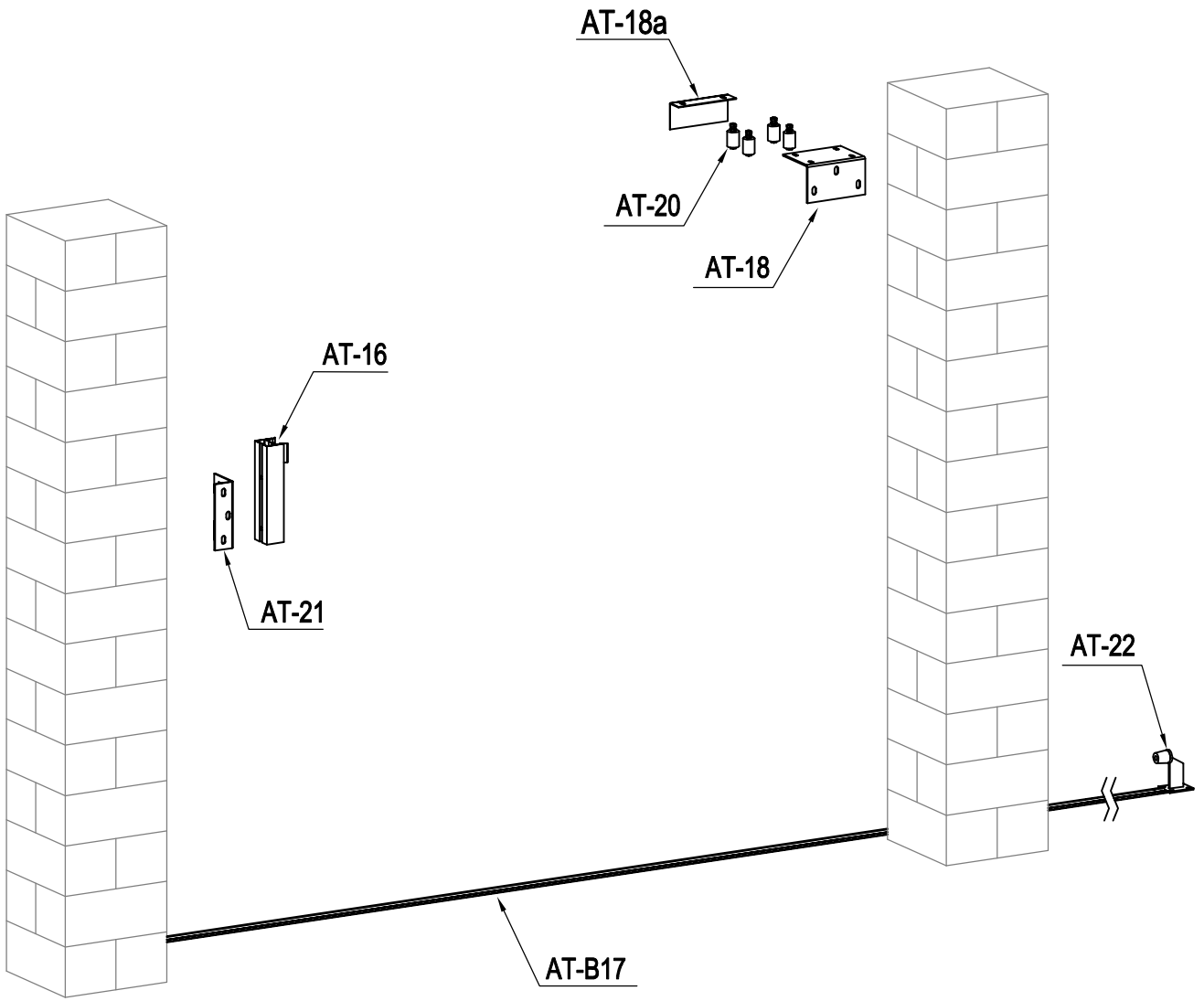









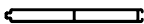

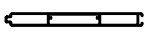







































# PART LIST

IMAGE	NO.	L.(mm)	QTY	Box NO.	IMAGE	NO.	L.(mm)	QTY	Box NO.
	AT-B1a	1728	3	1/4		Dr-14		1	3/4
	AT-B2	1728	1	1/4		AT-18		1	3/4
	AT-30	250	1	3/4		AT-18a		1	3/4
	AT-30a	250	1	3/4		AT-19		4	3/4
	AT-C3a	1721	4	1/4		AT-20		4	3/4
	AT-C4	1245	18	2/4		AT-21		1	3/4
	AT-C4a	1245	2	1/4		AT-22		1	3/4
	AT-D5	1603	1	1/4		AT-23		2	3/4
	AT-B5a	550.5	1	1/4		Dr-18		1	3/4
	Dr-A5b	937	1	1/4		Dr-19		1	3/4
	AT-B5b	1728	1	1/4		Dr-20a		1	3/4
	AT-29	193	2	3/4		Dr-21		1	3/4
	AT-B10	1553	2	4/4		Dr-22		1	3/4
	AT-B6	1556	2	1/4		Dr-25		1	3/4
	AT-B8	1555	2	1/4		Dr-25a		2	3/4
	AT-B8a	1555	2	1/4		Dr-27		2	3/4
	AT-A8b	308.5	4	1/4		AT-N30		4	3/4
	AT-B11	1728	4	1/4		AT-N31		10	3/4
	AT-A11a	250	2	3/4		AT-N32		32	3/4
	AT-31	250	2	3/4		AT-N33		4	3/4
	AT-B7a	1675	1	1/4		AT-N34		72	3/4
	AT-B14	1588	2	3/4		AT-N35		6	3/4
	AT-B14a	1588	2	3/4		AT-N36		2	3/4
	VT-B15	1587	2	3/4		AT-N37		8	3/4
	AT-16	260	1	3/4		AT-N38		50	3/4
	AT-B17	1412	5	3/4		AT-N39		8	3/4
	AT-17		2	3/4		Dr-28		6	3/4
	AT-17a		2	3/4		AT-22J		7	3/4
	AT-10		4	3/4		ATW-14		1	3/4
	Dr-13		1	3/4					

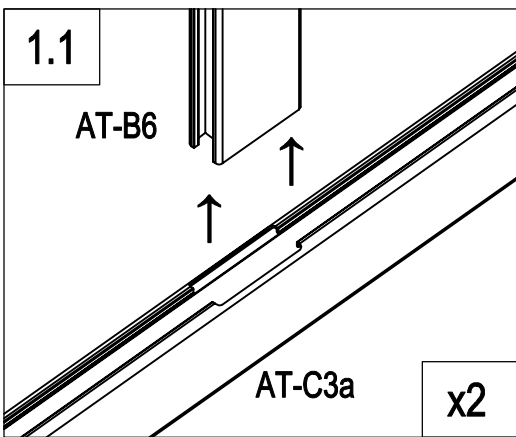
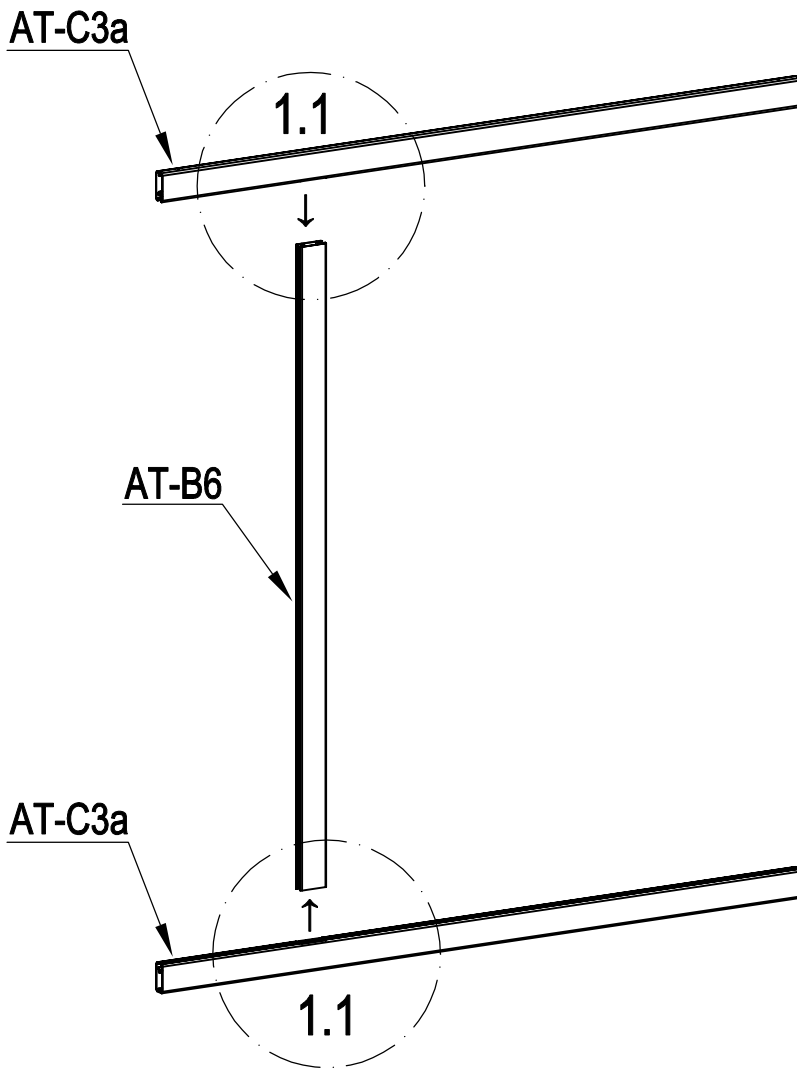



	AT-B6	1
	AT-C3a	2

FR: vous pouvez retourner et changer la direction de cette plaque pour personnaliser votre portail

EN: you can flip and switch the direction of this plate to personalize your gate

DE: Sie können dieses Schild umdrehen und die Richtung wechseln, um Ihr Tor zu personalisieren.

ES: puedes girar y cambiar la dirección de esta placa para personalizar tu puerta

IT: potete capovolgere e cambiare la direzione di questa piastra per personalizzare il vostro cancello

NL: u kunt de richting van deze plaat omdraaien en veranderen om uw poort te verpersoonlijken...

PT: Você pode virar e mudar a direção desta placa para personalizar seu portão.

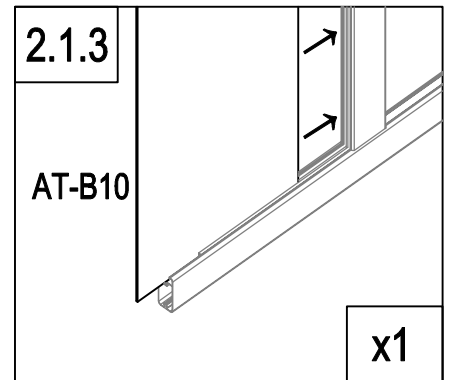
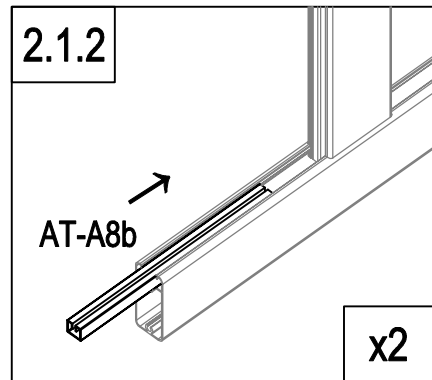
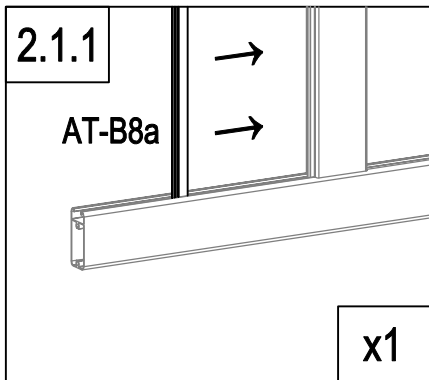
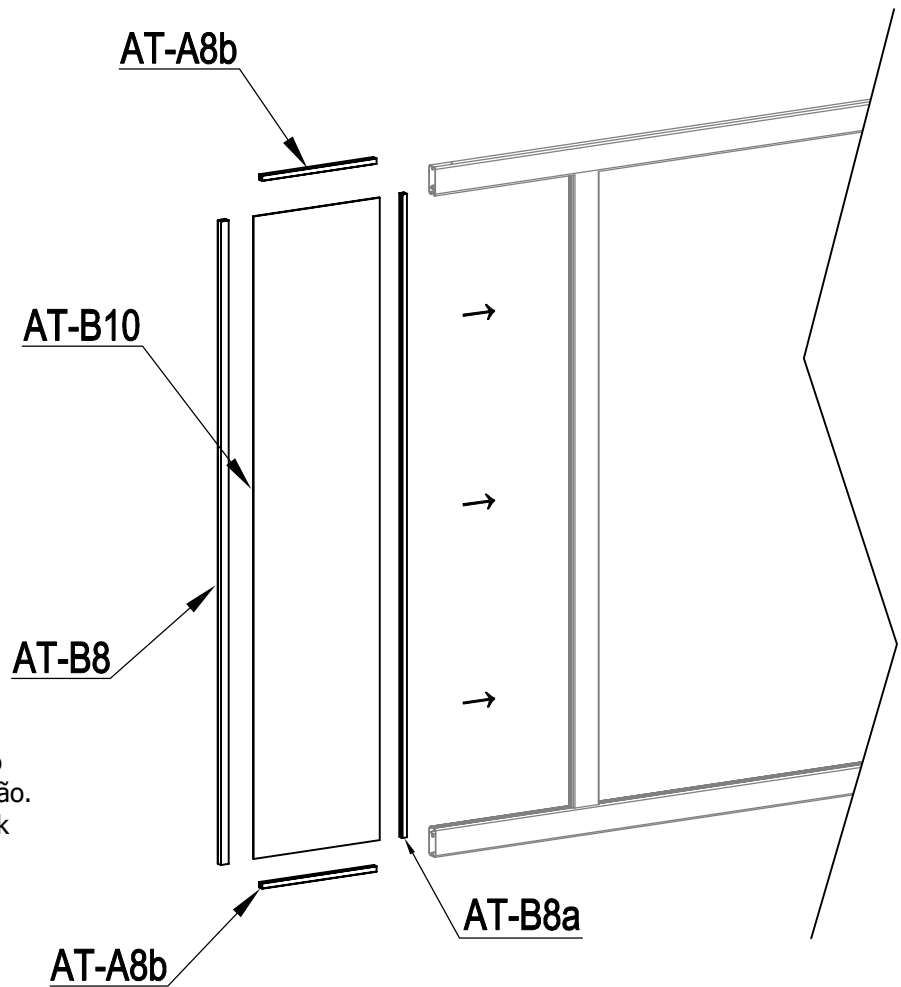

PL: Możesz odwrócić i zmienić kierunek tej płytki, aby spersonalizować swoją bramę.



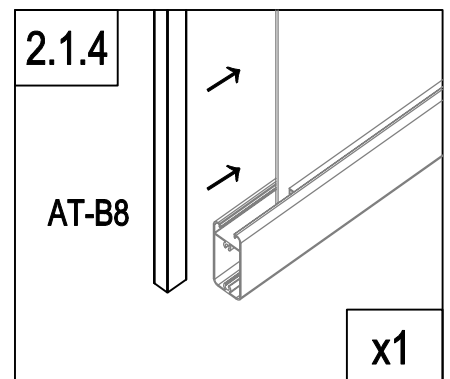

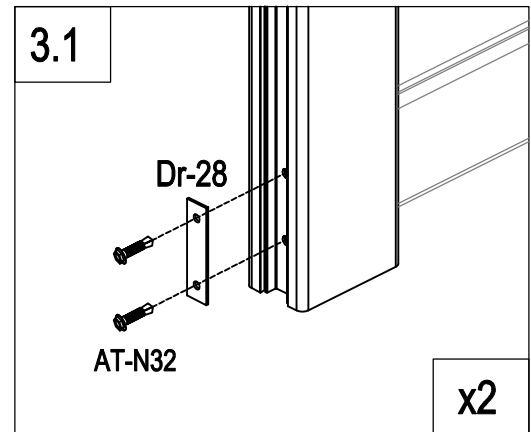
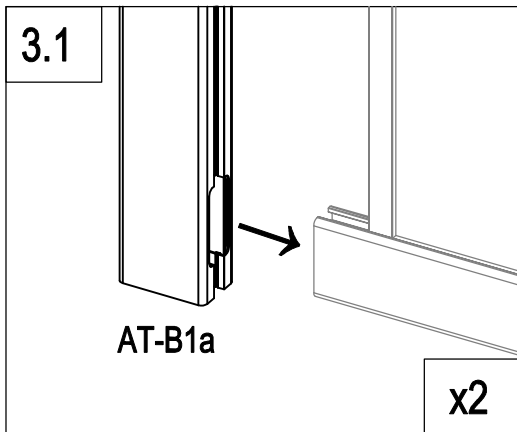
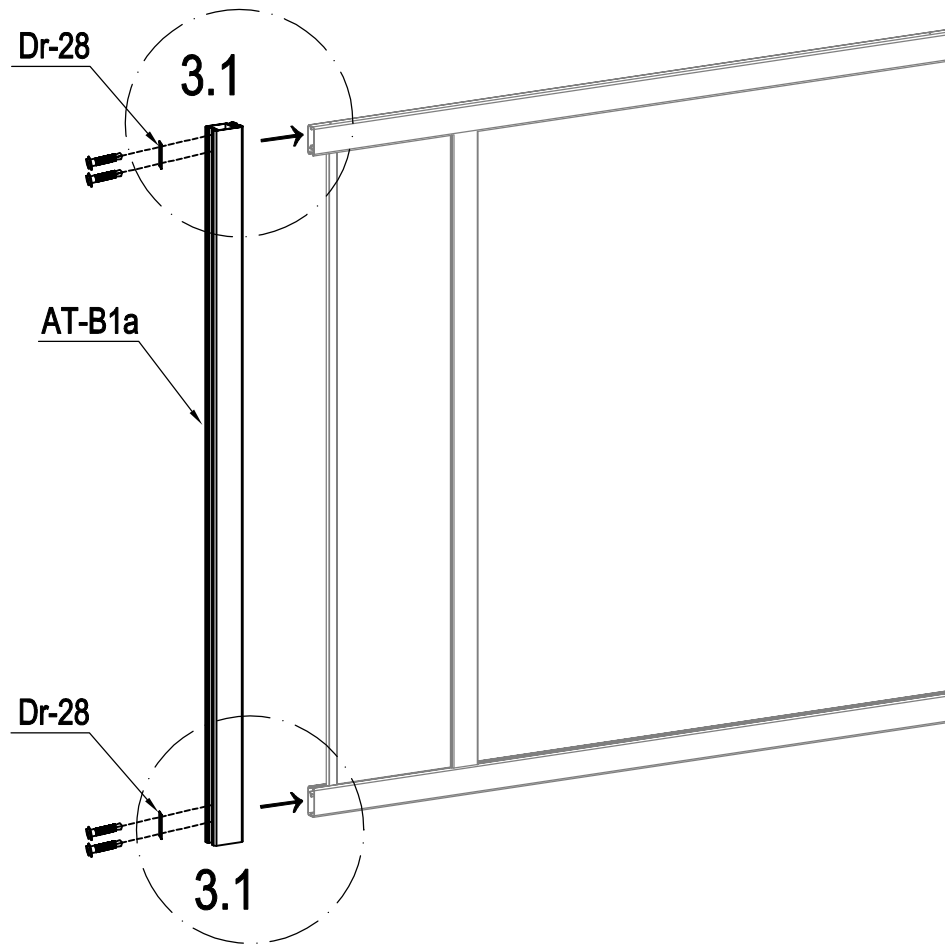
	AT-B8a	1
	AT-A8b	2
	AT-B10	1
	AT-B8	1



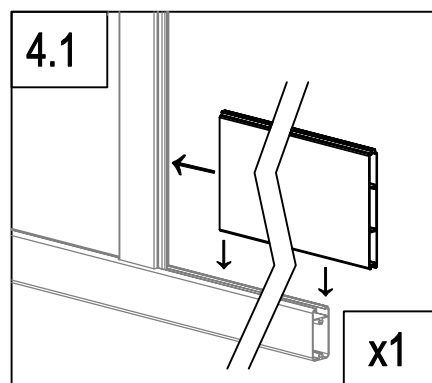
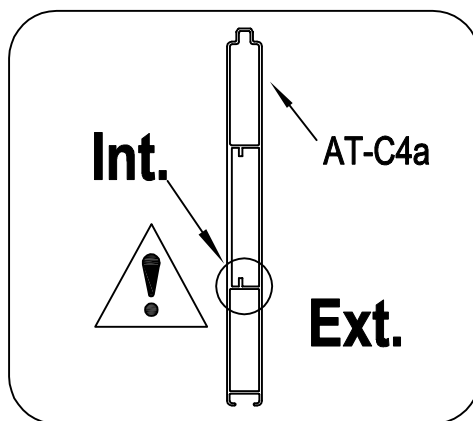
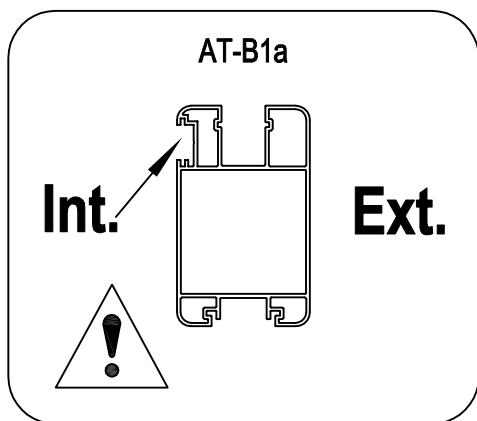
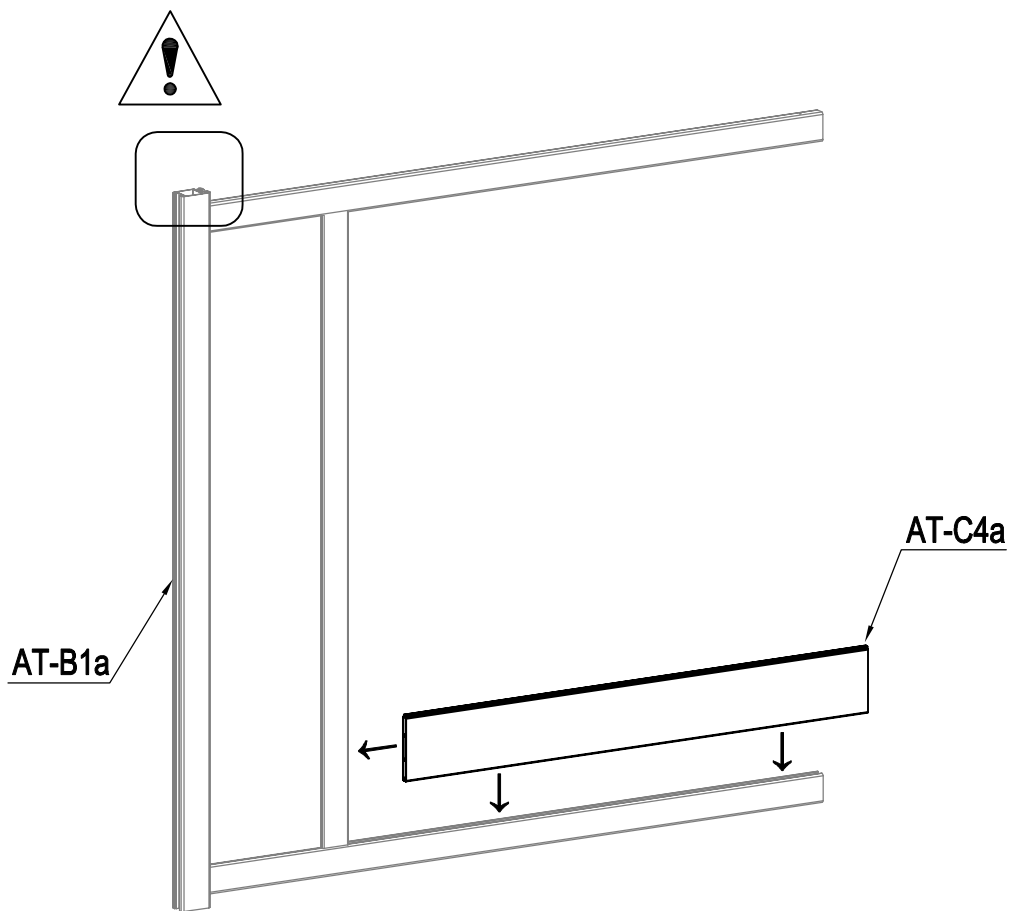

	AT-B1a	1
	Dr-28	2
	AT-N32	4



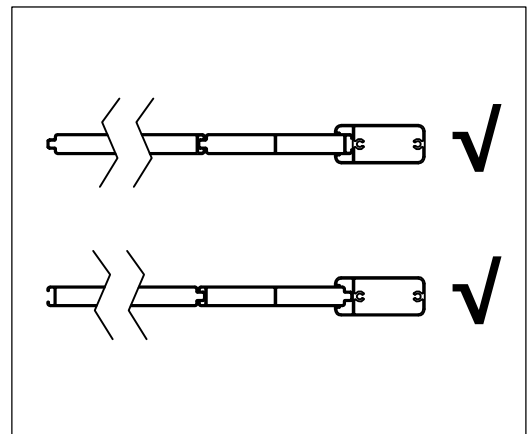
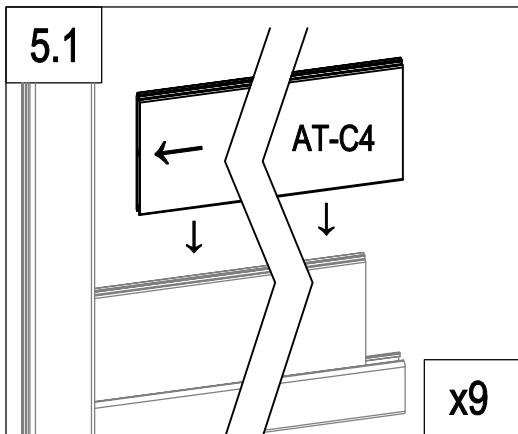
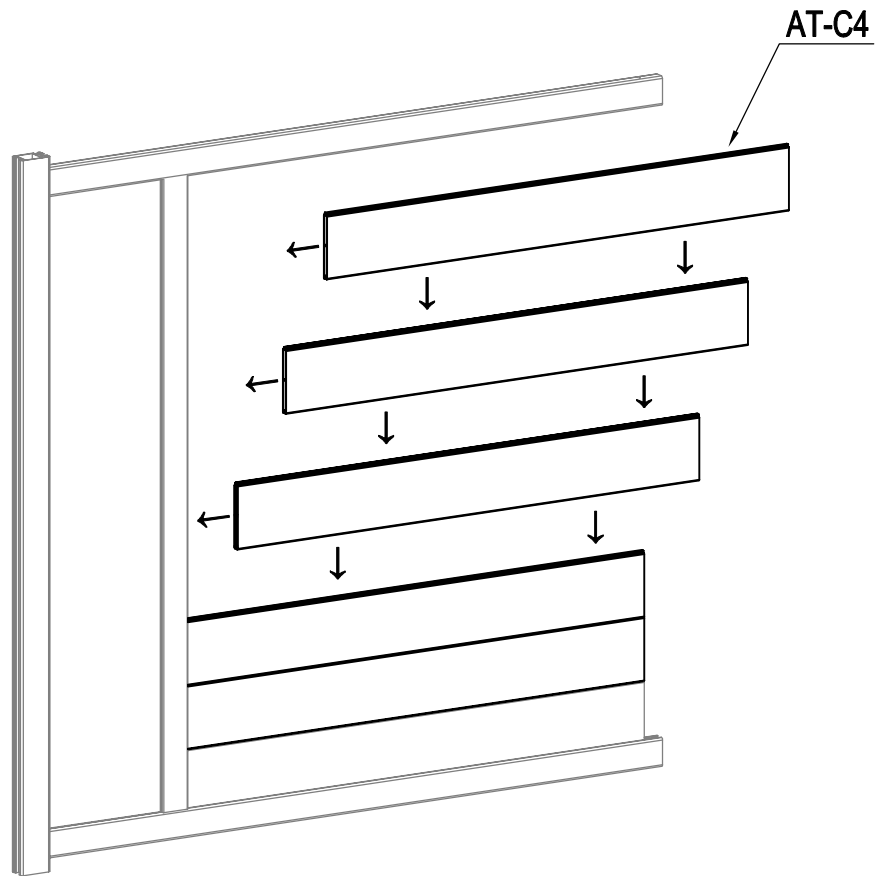

	AT-C4a	1
---	--------	---

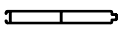

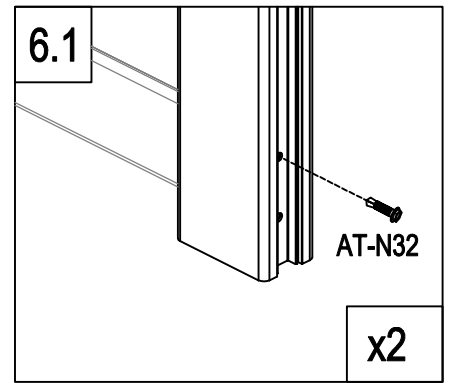
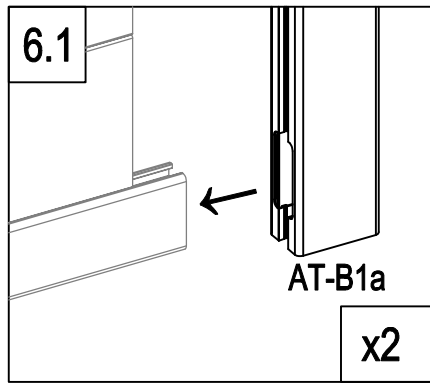
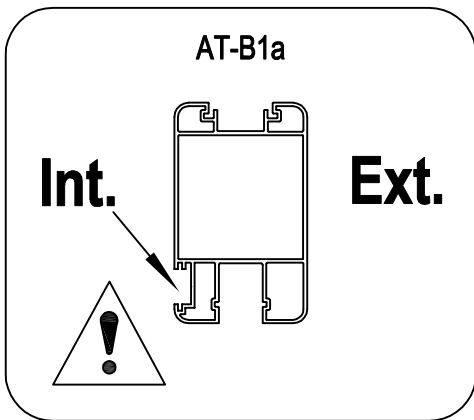
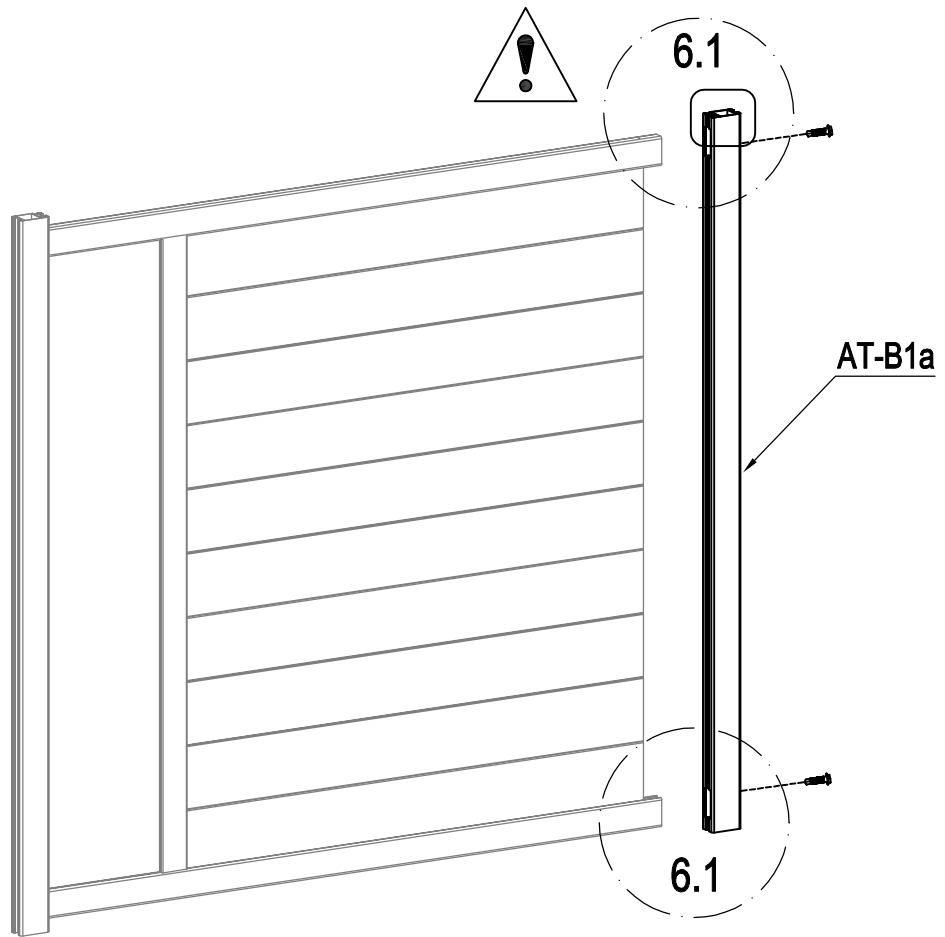

	<b>AT-C4</b>	<b>9</b>
---	--------------	----------

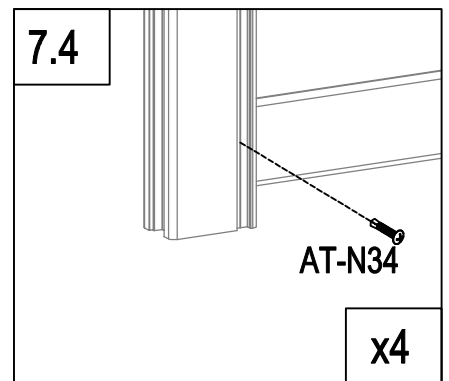
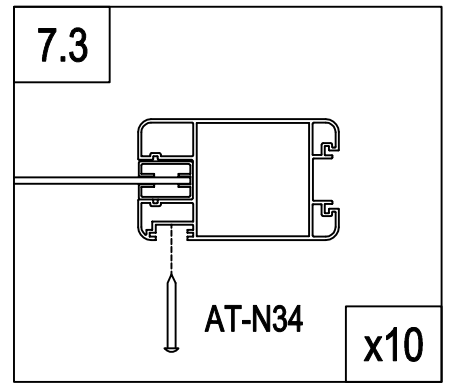
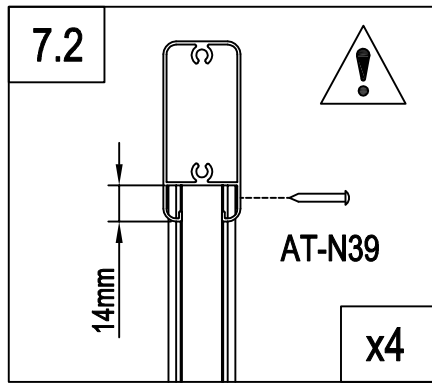
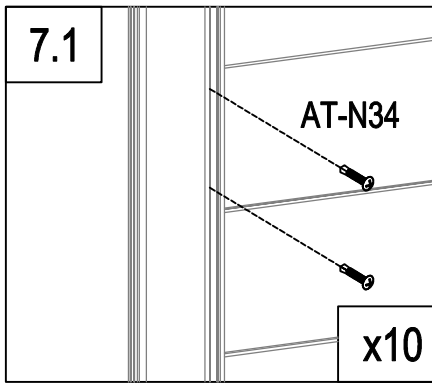
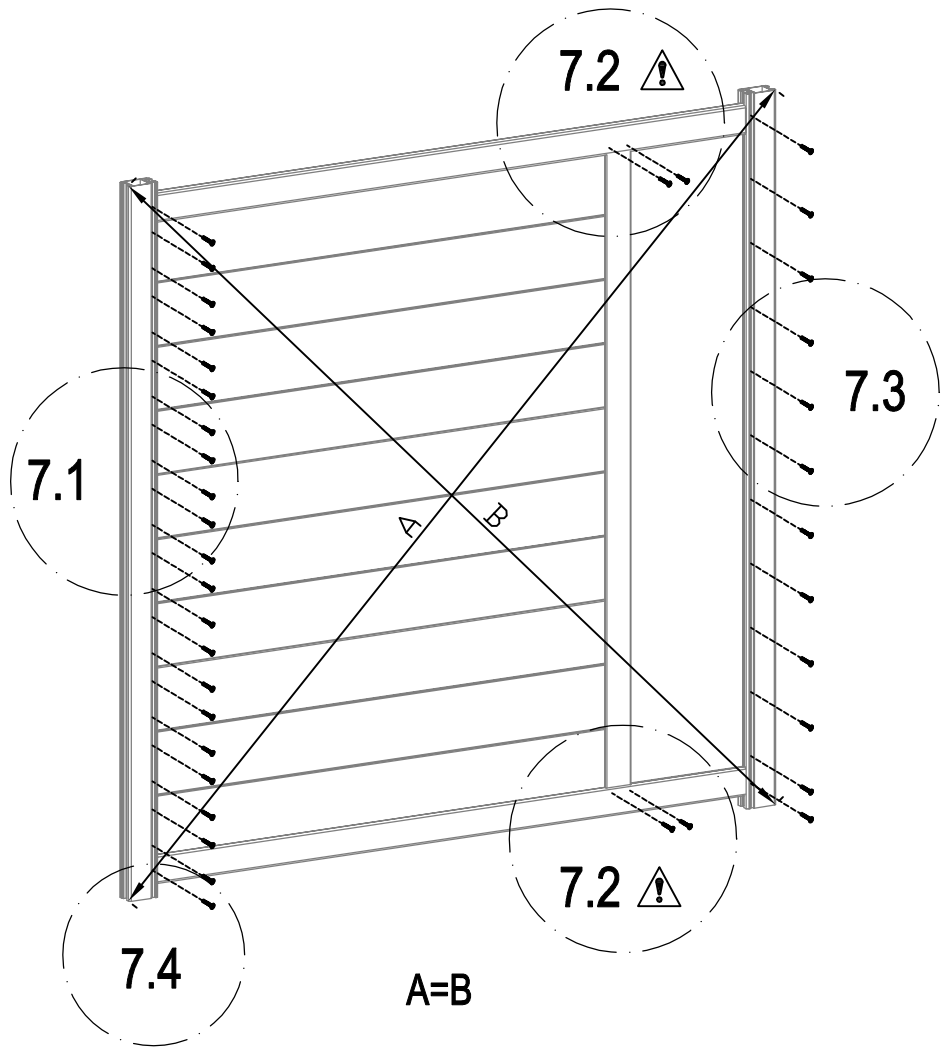

	AT-B1a	1
	AT-N32	2





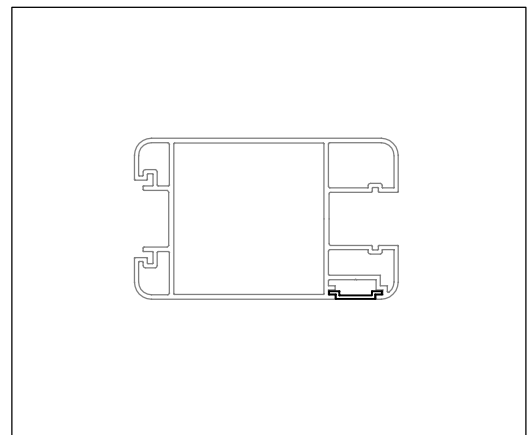
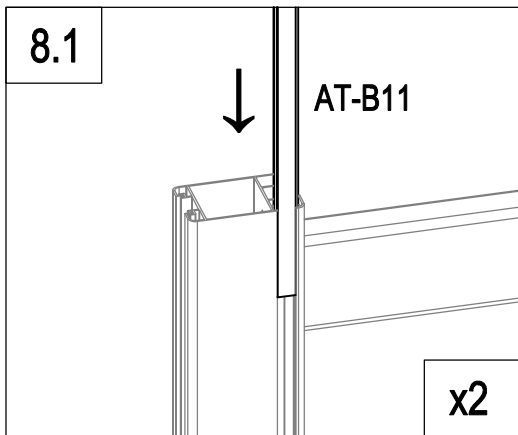
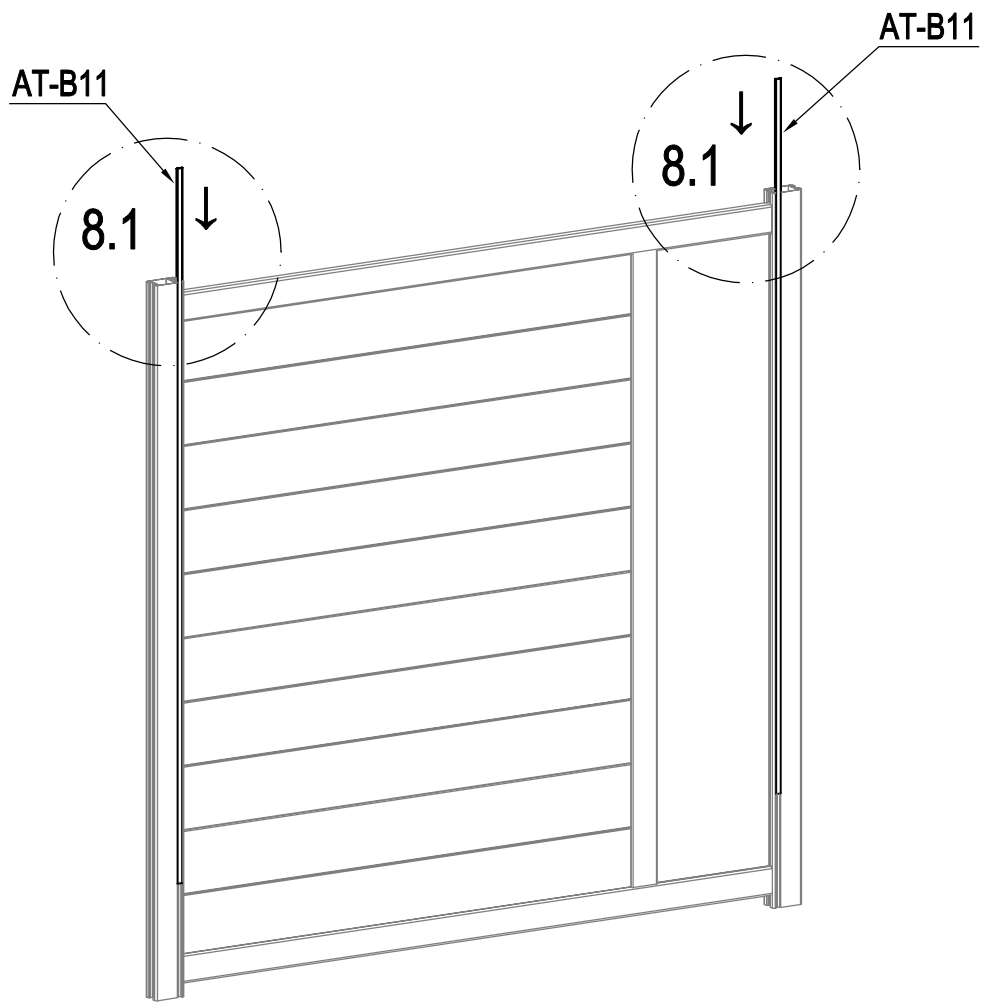

	AT-N34	34
	AT-N39	4

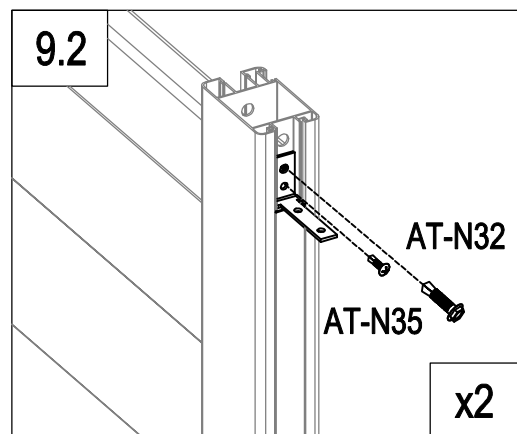
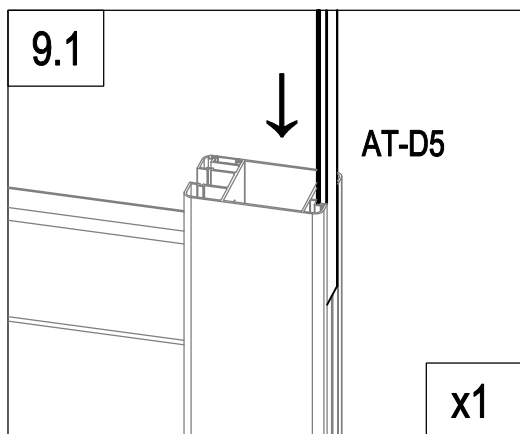
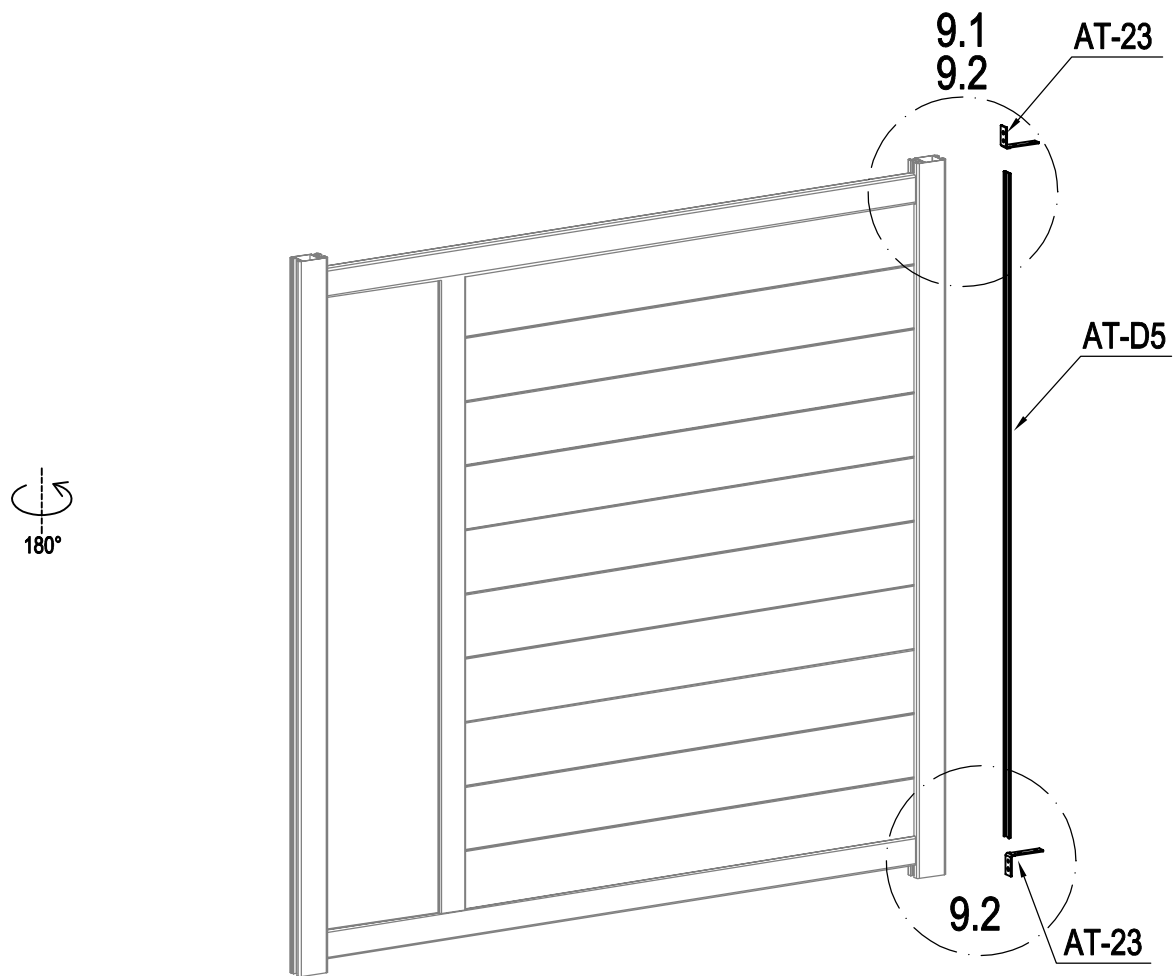

	AT-B11	2
---	--------	---





	AT-D5	1
	AT-23	2
	AT-N32	2
	AT-N35	2

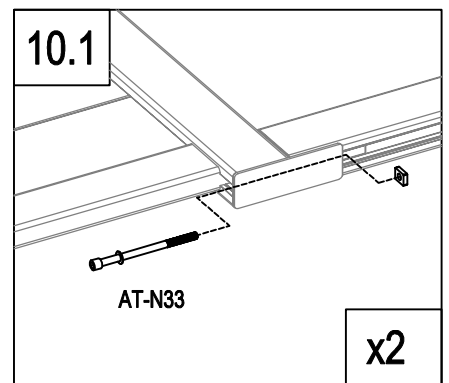
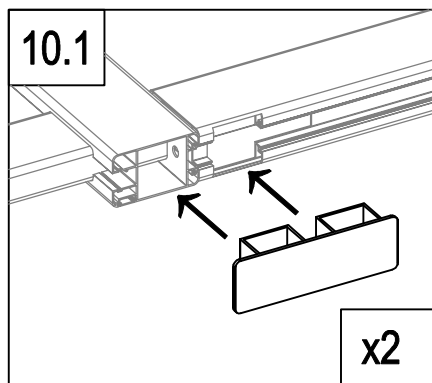
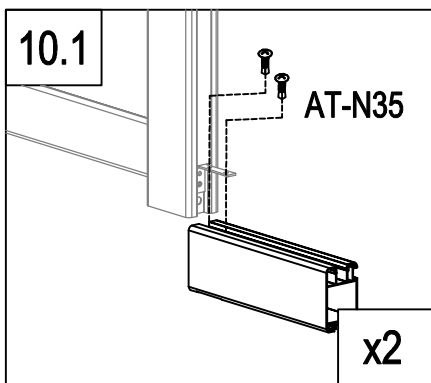
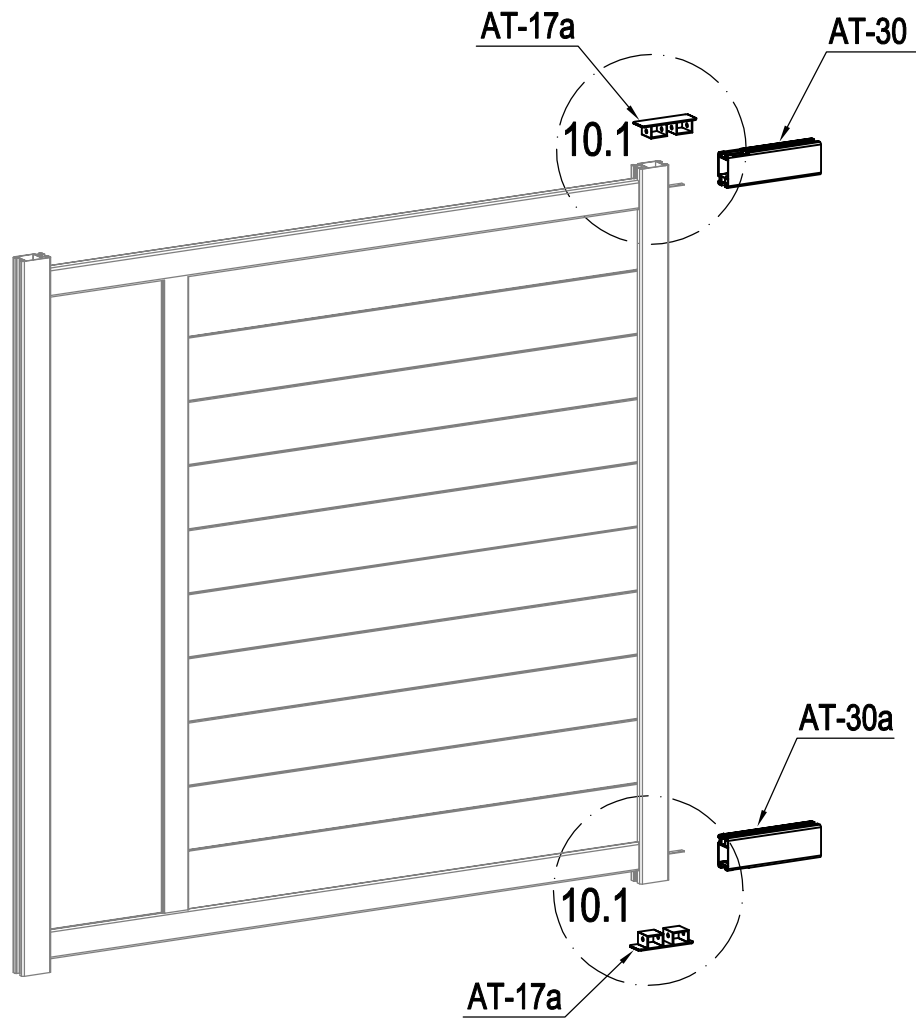

	AT-30	1
	AT-30a	1
	AT-17a	2

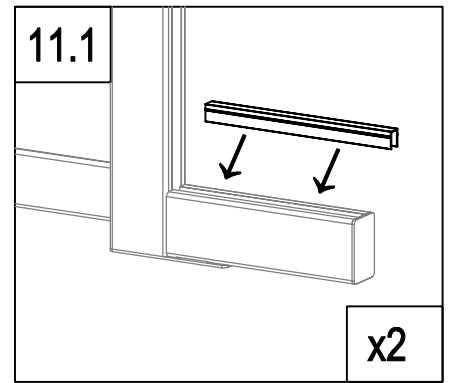
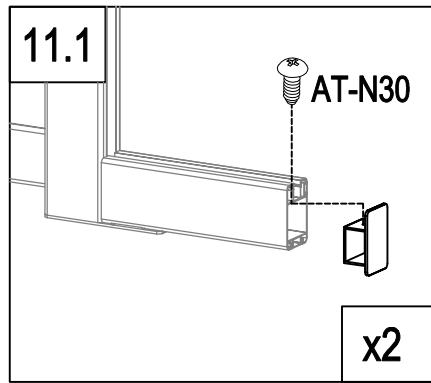
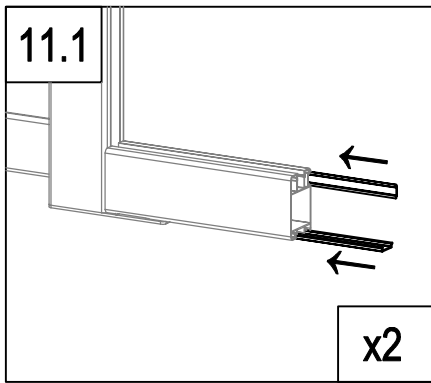
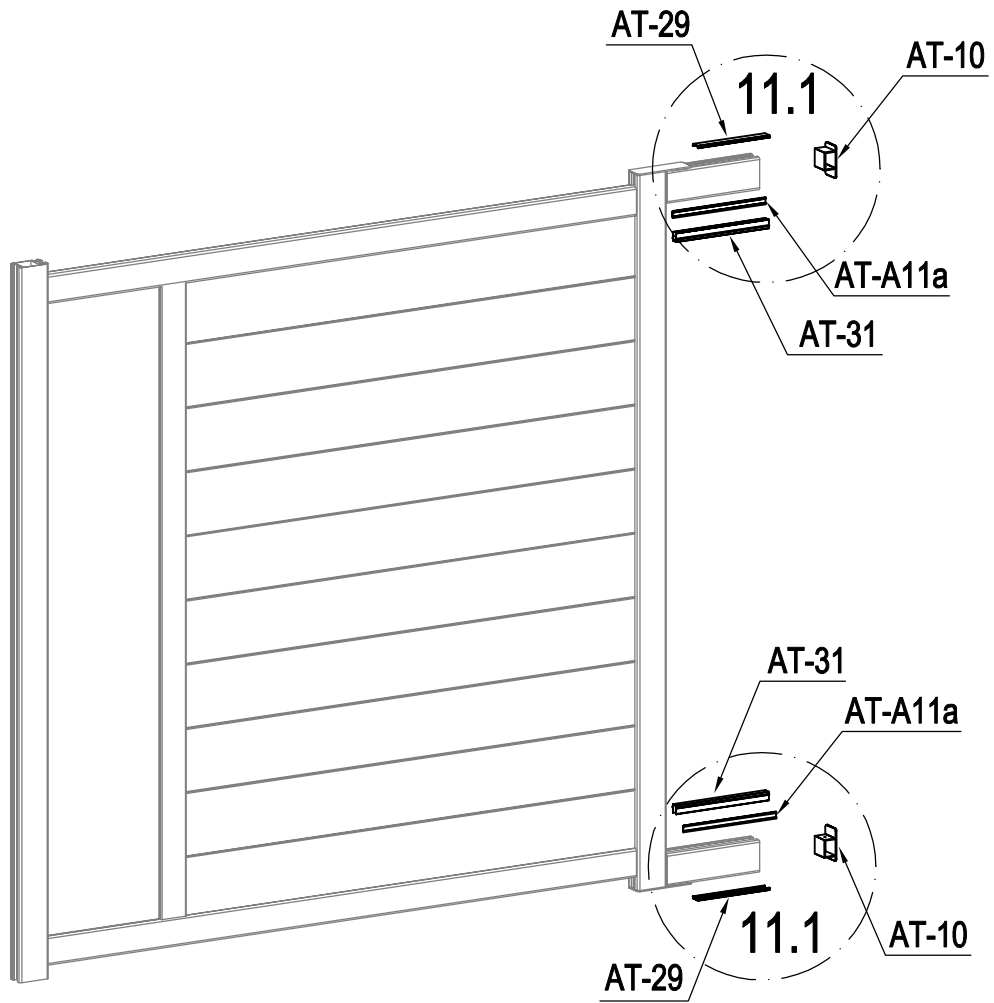

	AT-N33	2
	AT-N35	4

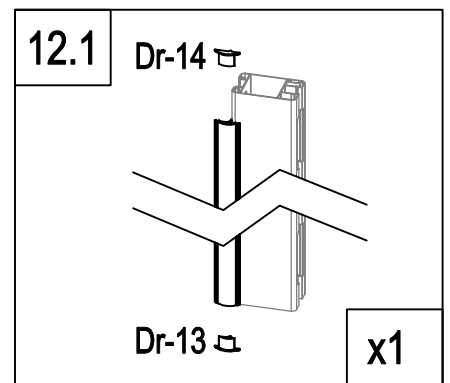
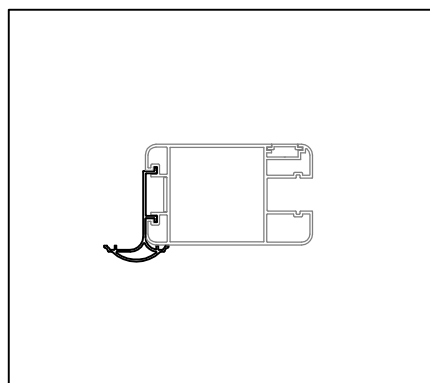
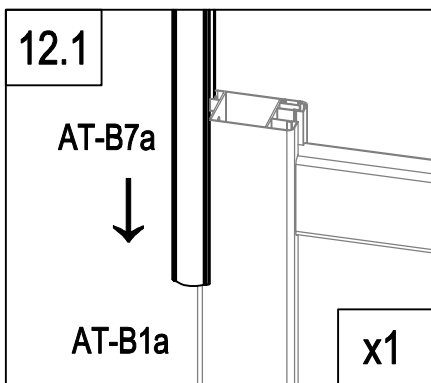
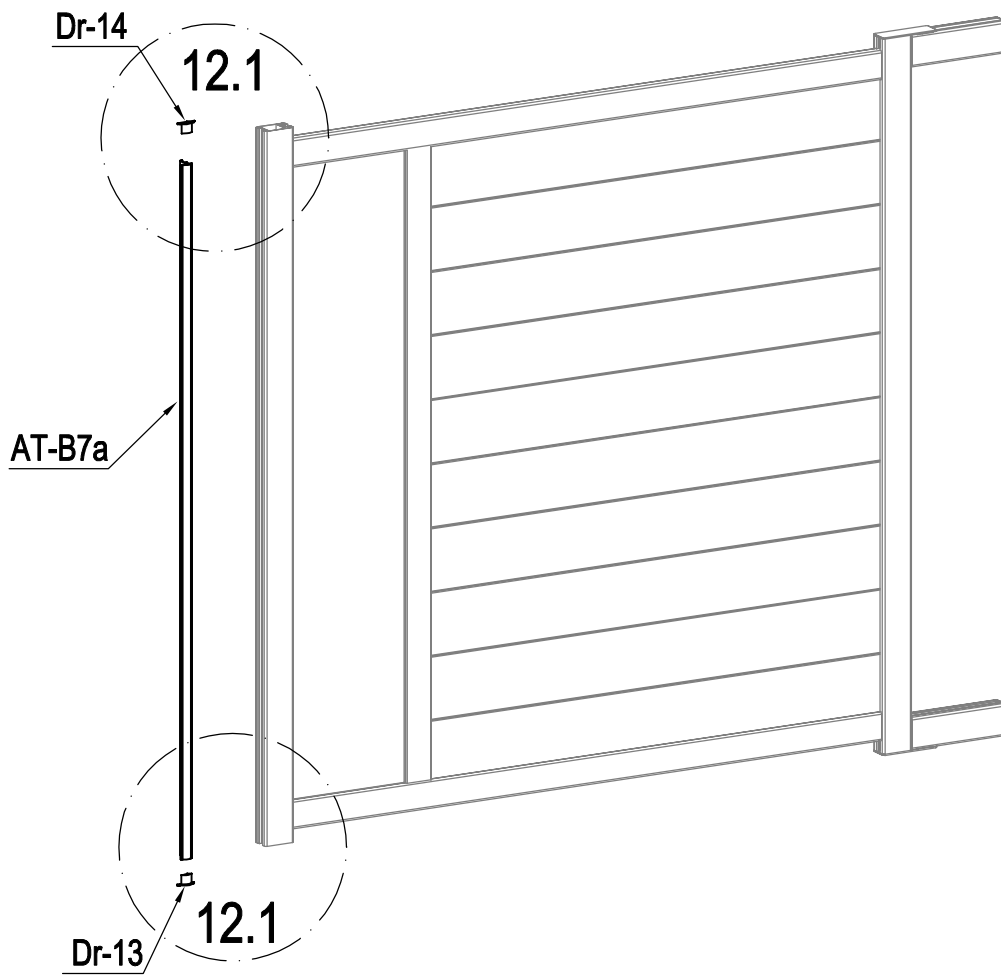

	AT-29	2
	AT-A11a	2
	AT-31	2

	AT-10	2
	AT-N30	2



	AT-B7a	1
	Dr-13	1
	Dr-14	1

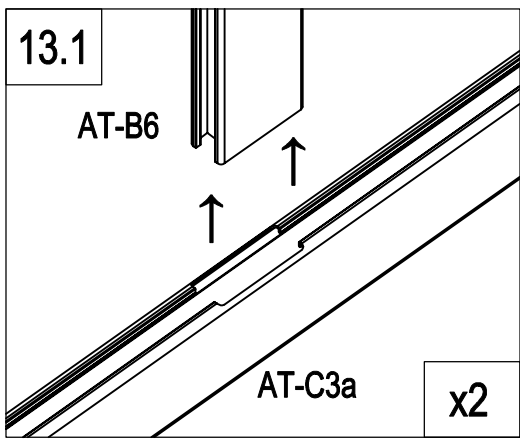
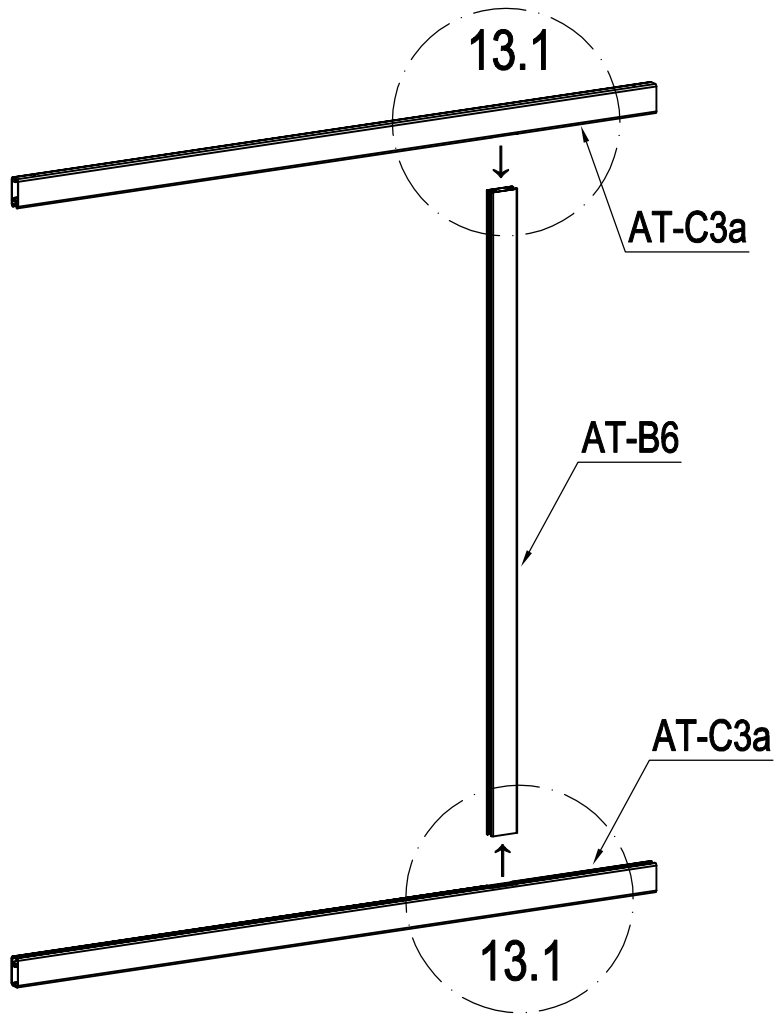

	AT-B6	1
	AT-C3a	2

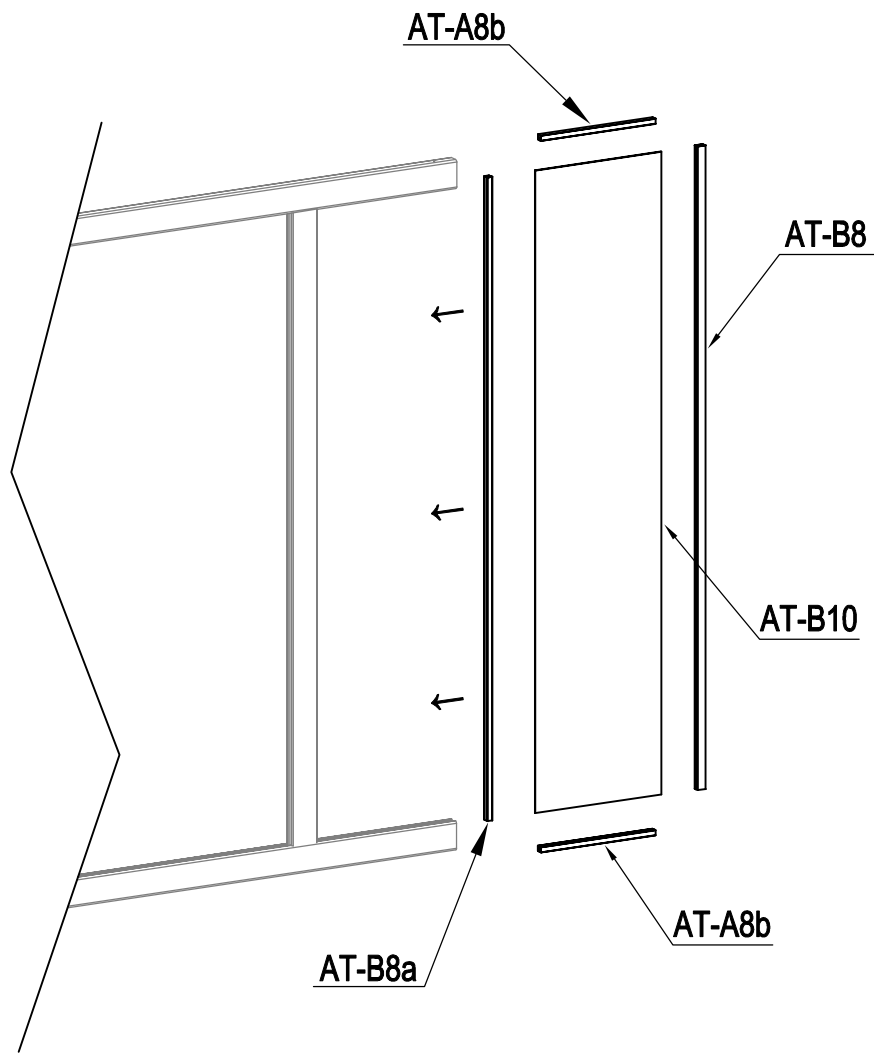



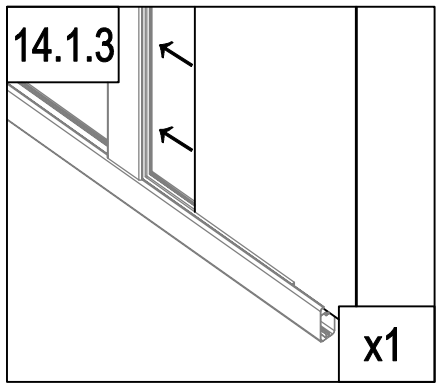
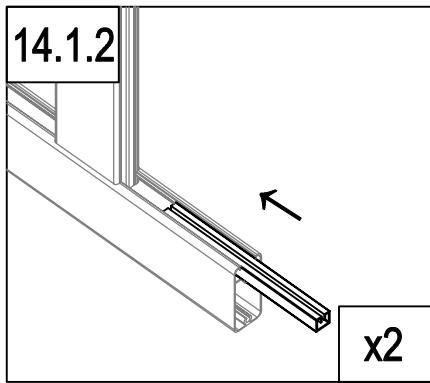
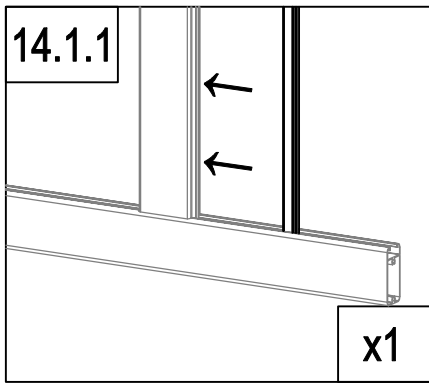

FR: vous pouvez retourner et changer la direction de cette plaque pour personnaliser votre portail  
 EN: you can flip and switch the direction of this plate to personalize your gate  
 DE: Sie können dieses Schild umdrehen und die Richtung wechseln, um Ihr Tor zu personalisieren.  
 ES: puedes girar y cambiar la dirección de esta placa para personalizar tu puerta  
 IT: potete capovolgere e cambiare la direzione di questa piastra per personalizzare il vostro cancello  
 NL: u kunt de richting van deze plaat omdraaien en veranderen om uw poort te verpersoonlijken...  
 PT: Você pode virar e mudar a direção desta placa para personalizar seu portão.  
 PL: Możesz odwrócić i zmienić kierunek tej płytki, aby spersonalizować swoją bramę.

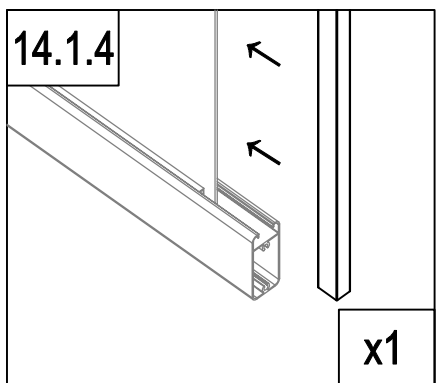

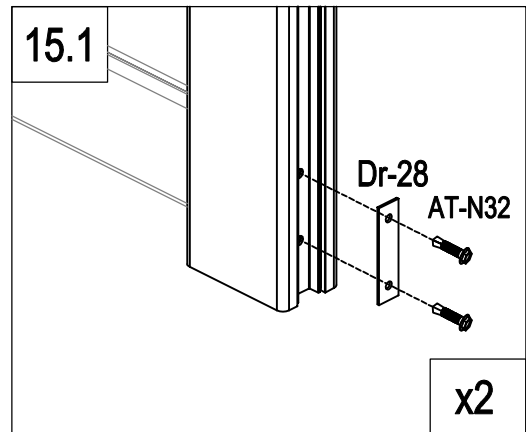
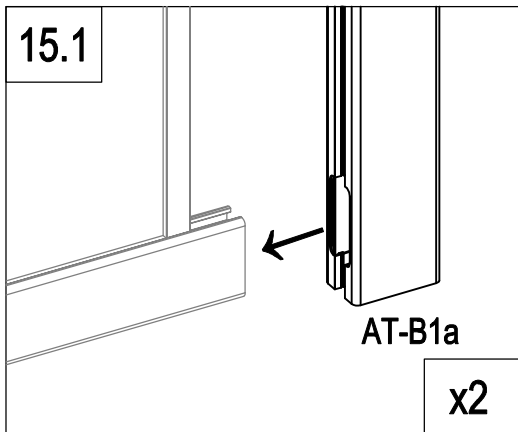
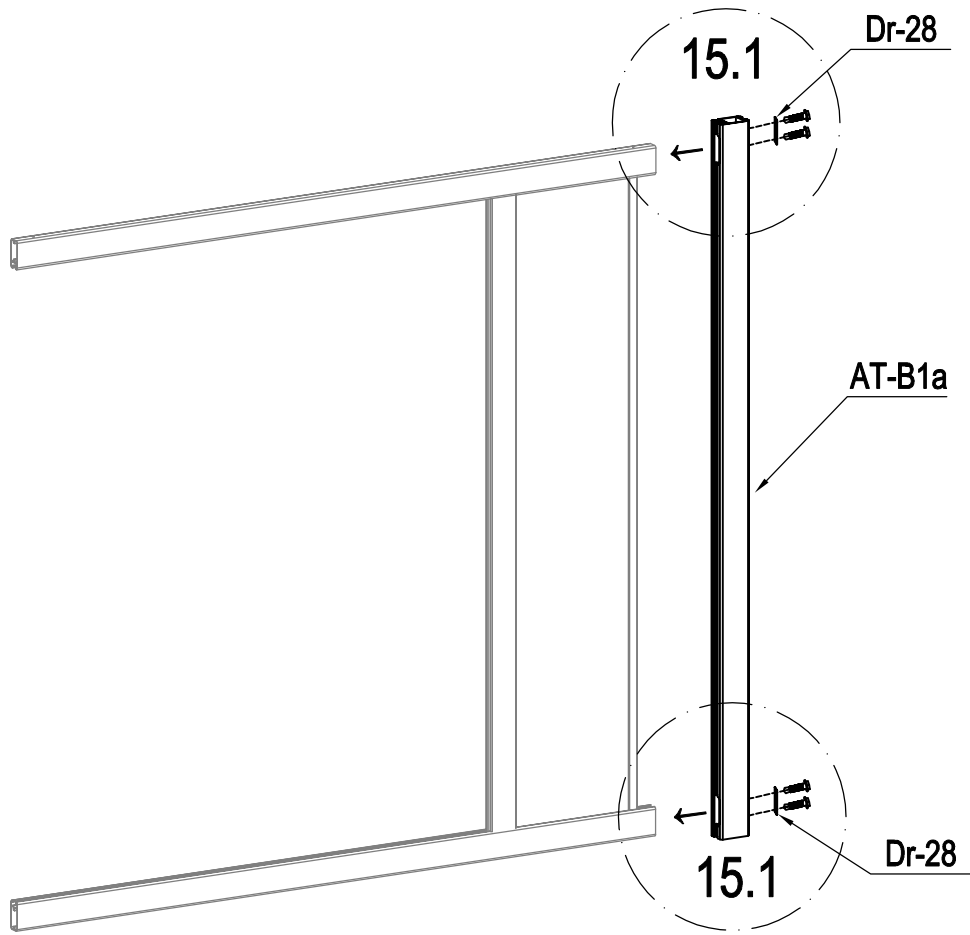
	AT-B8a	1
	AT-A8b	2
	AT-B10	1
	AT-B8	1





	AT-B1a	1
	Dr-28	2
	AT-N32	4

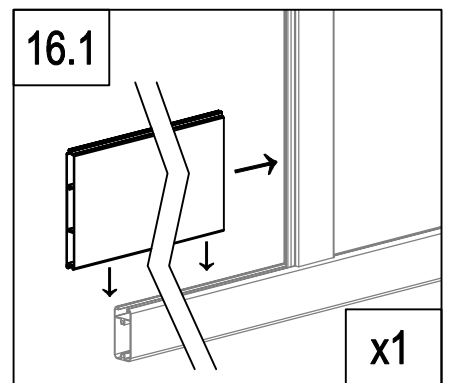
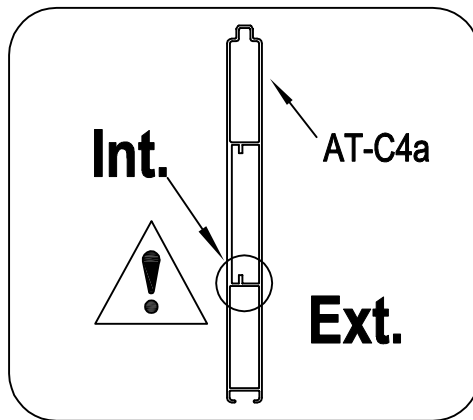
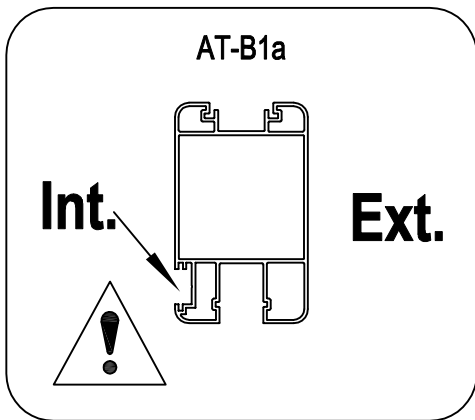
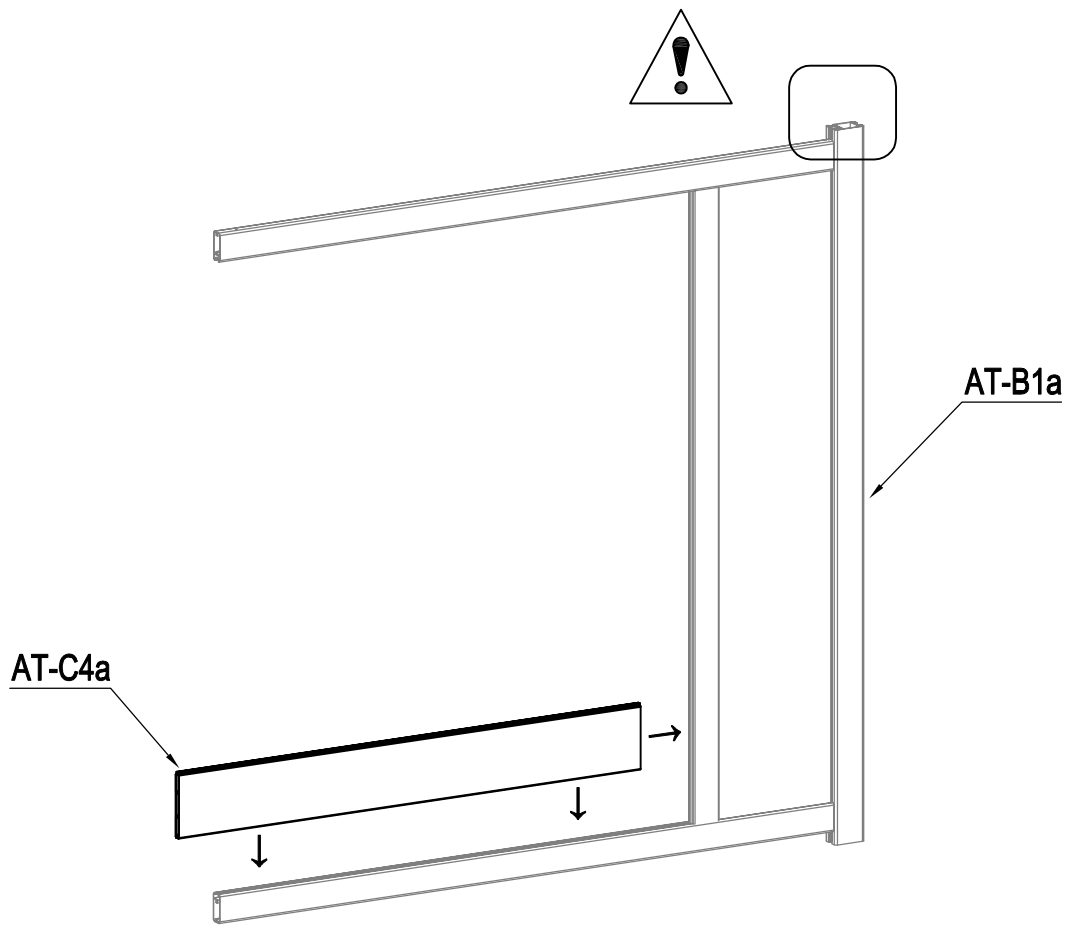



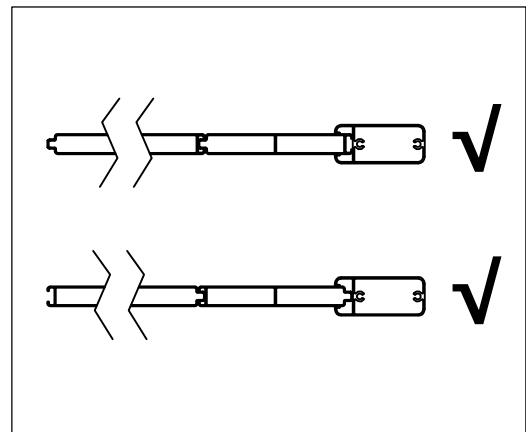
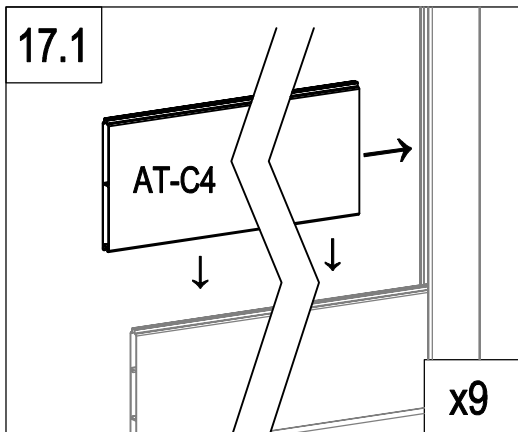
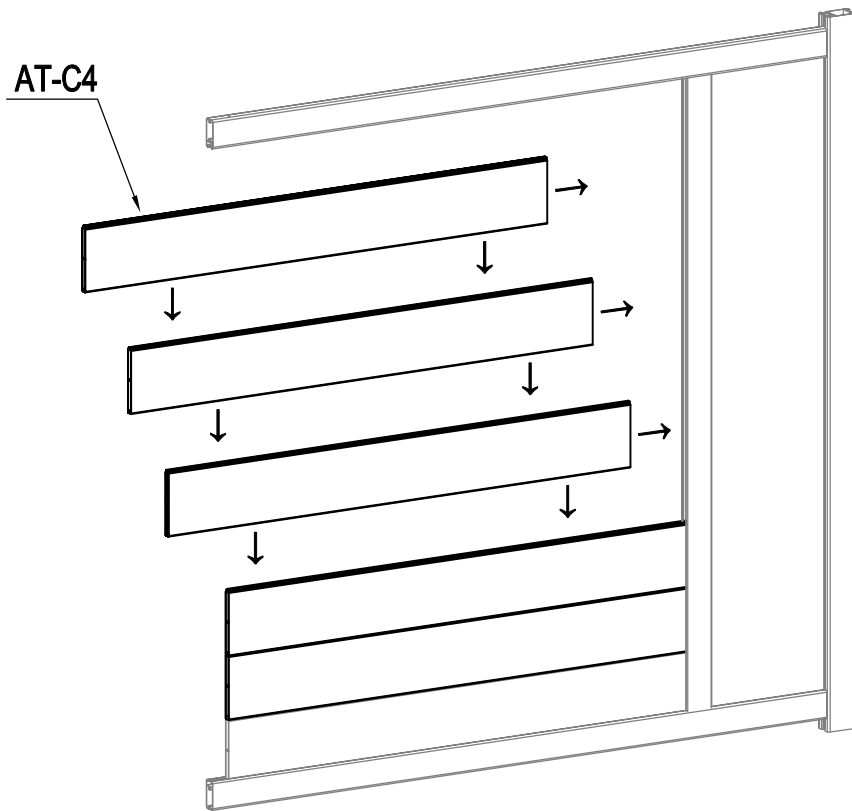

	AT-C4a	1
--	--------	---

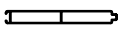

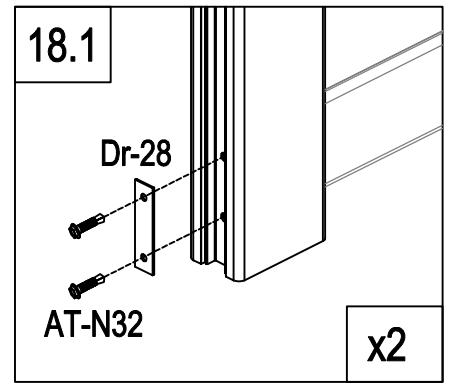
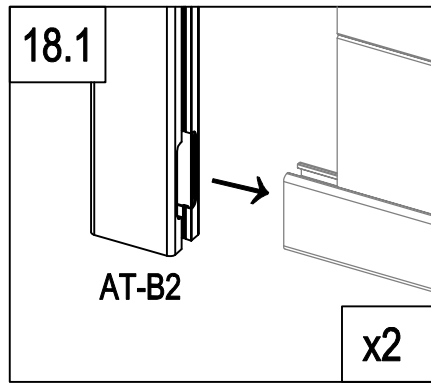
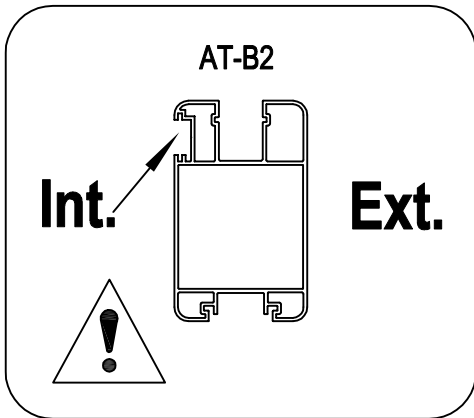
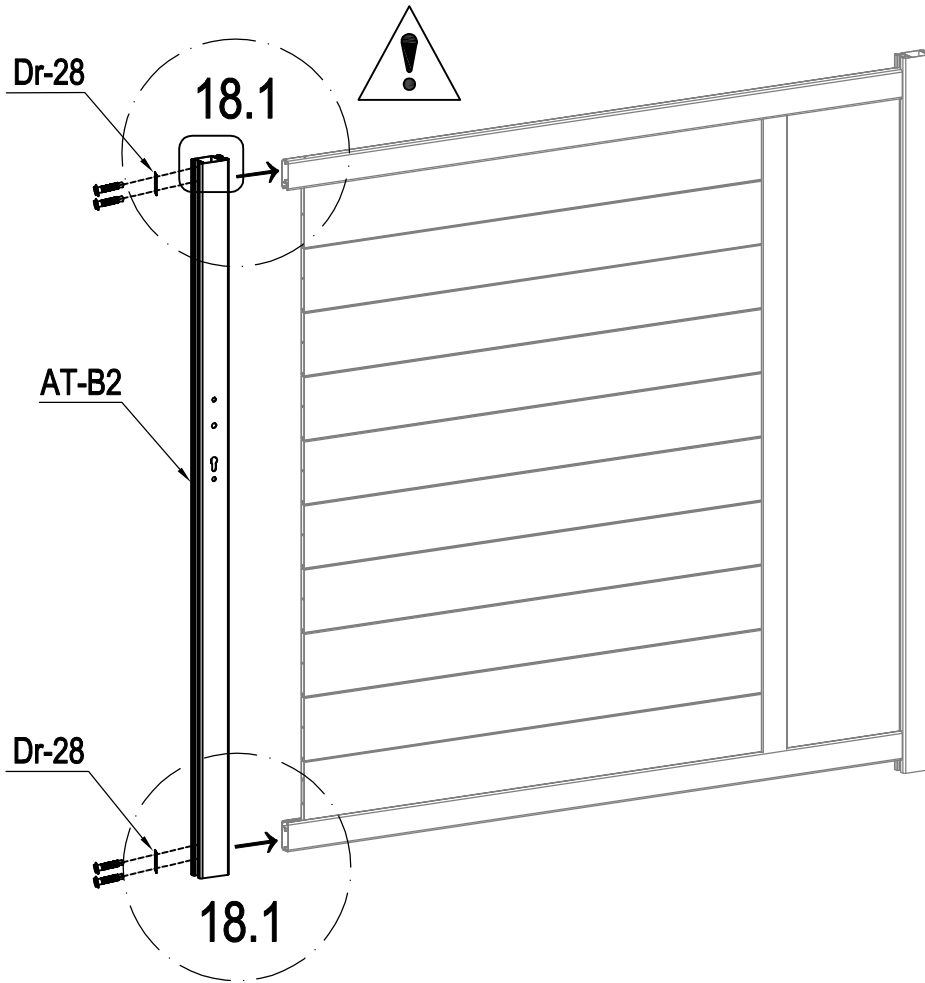



	AT-C4	9
---	-------	---

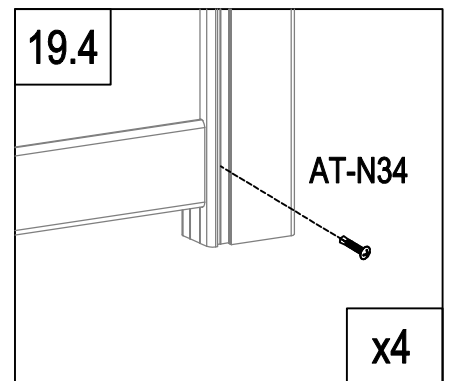
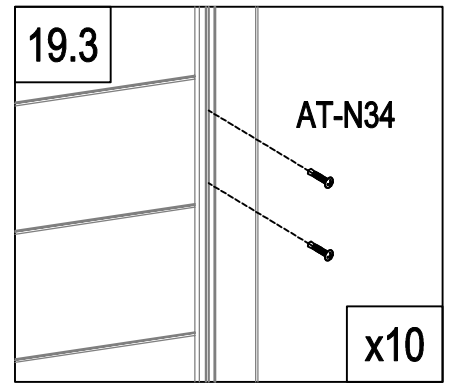
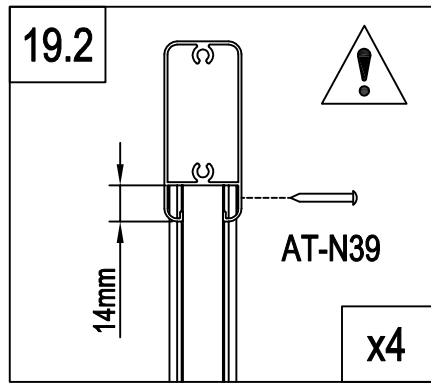
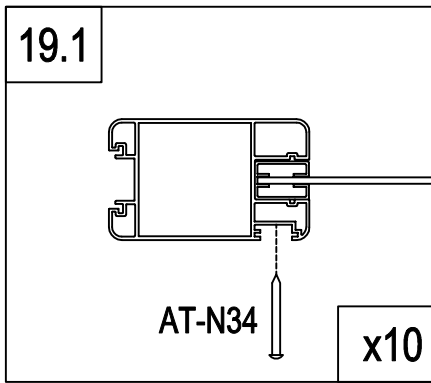
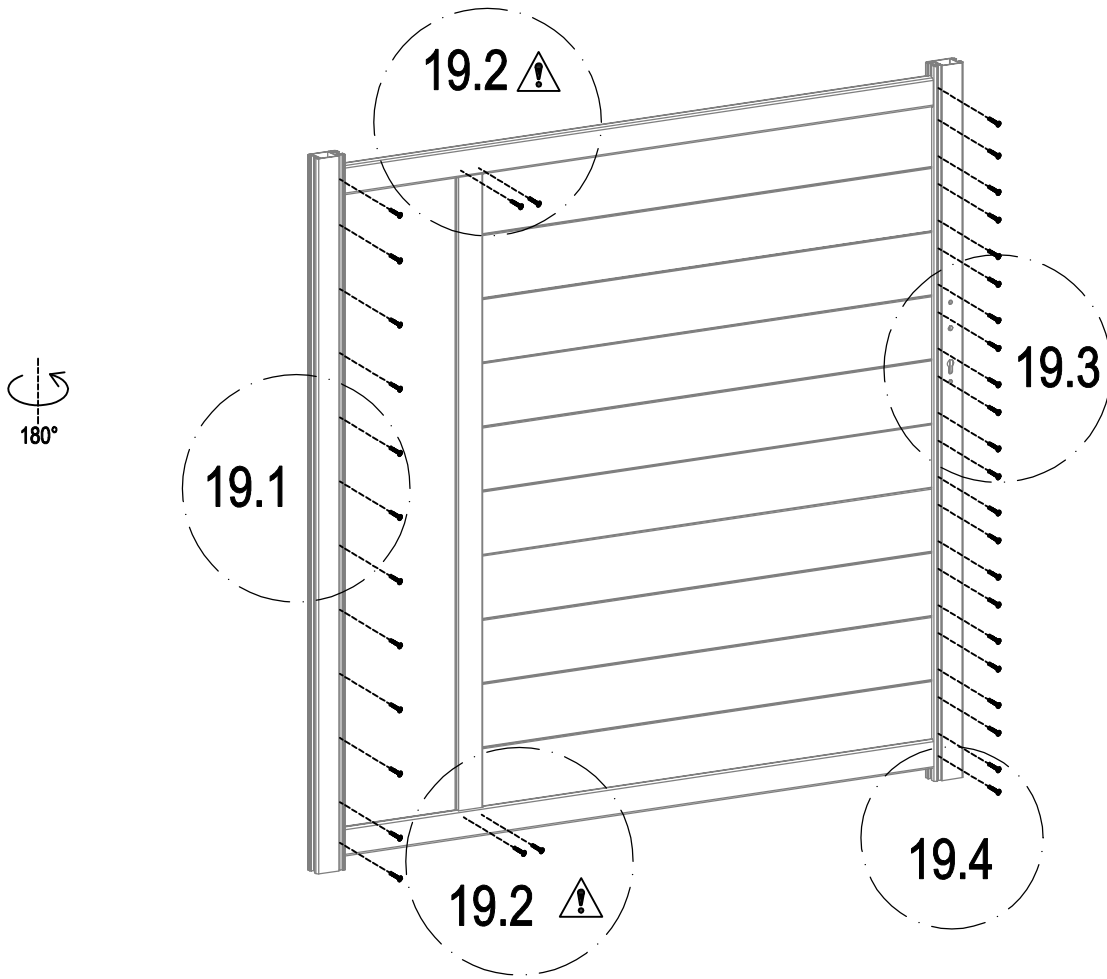

	AT-B2	1
	Dr-28	2
	AT-N32	4



	AT-N34	34
	AT-N39	4

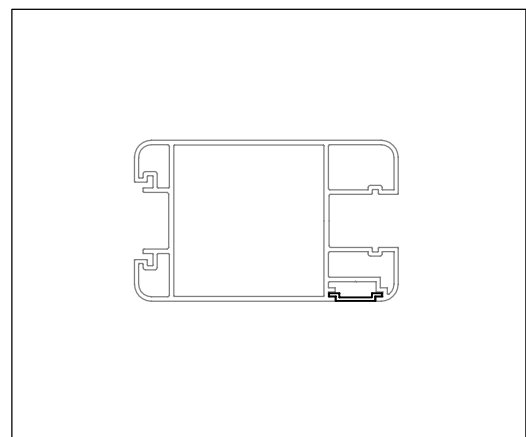
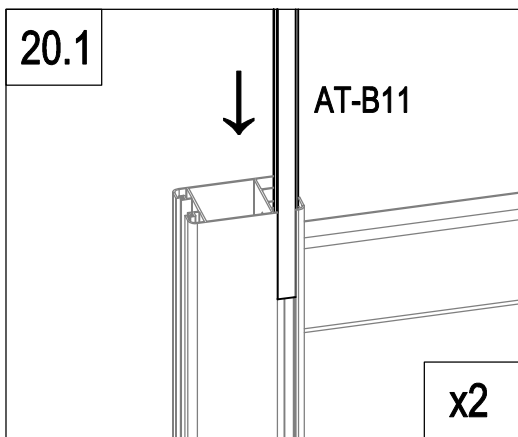
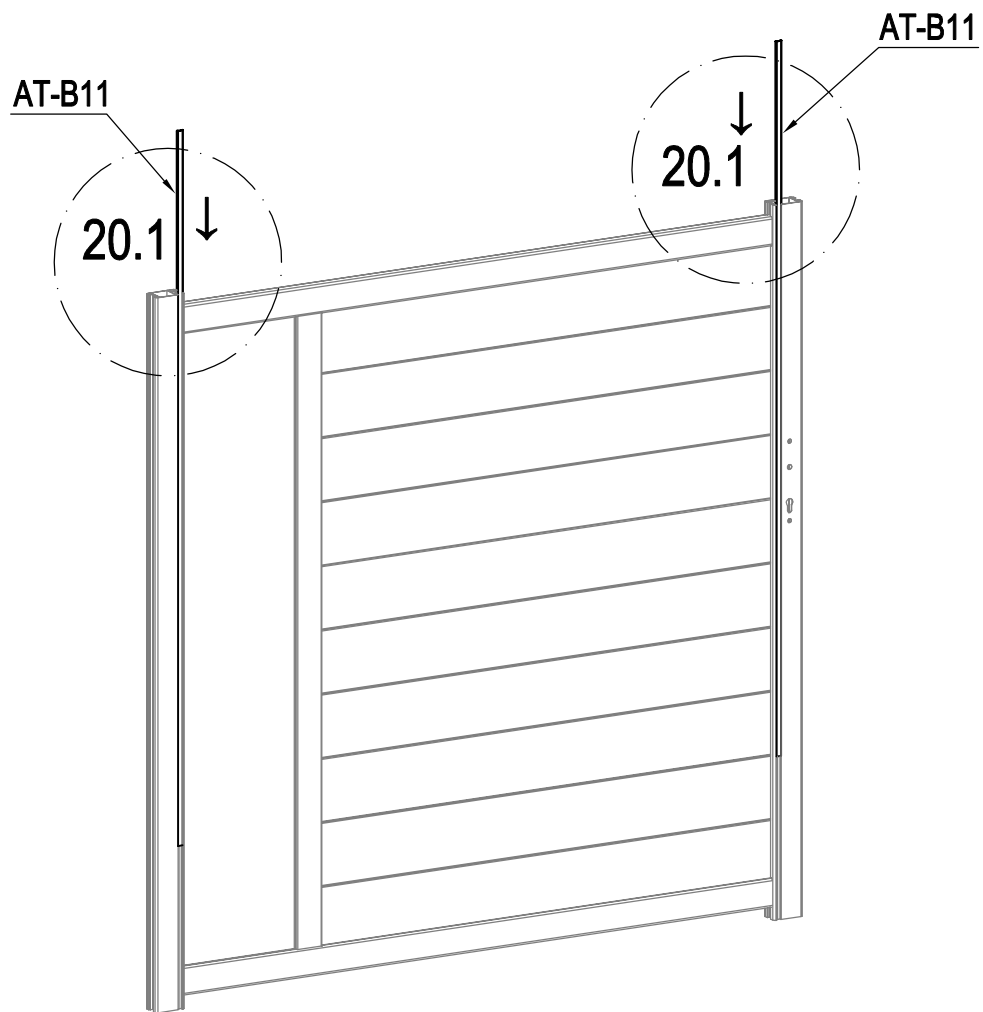

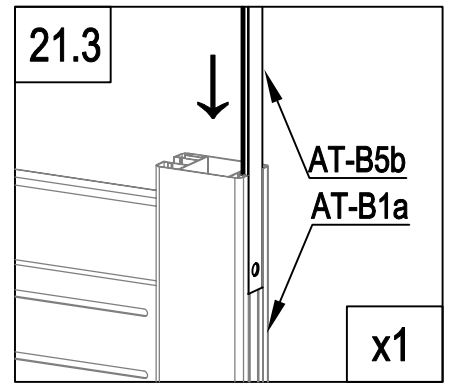
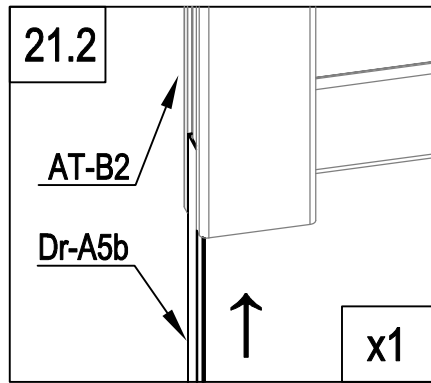
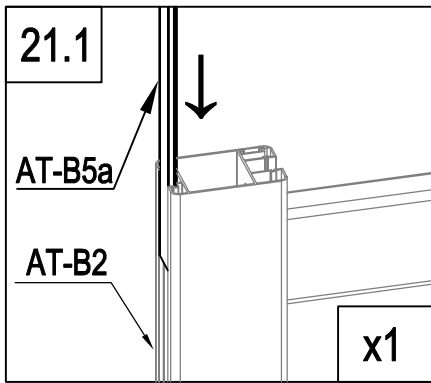
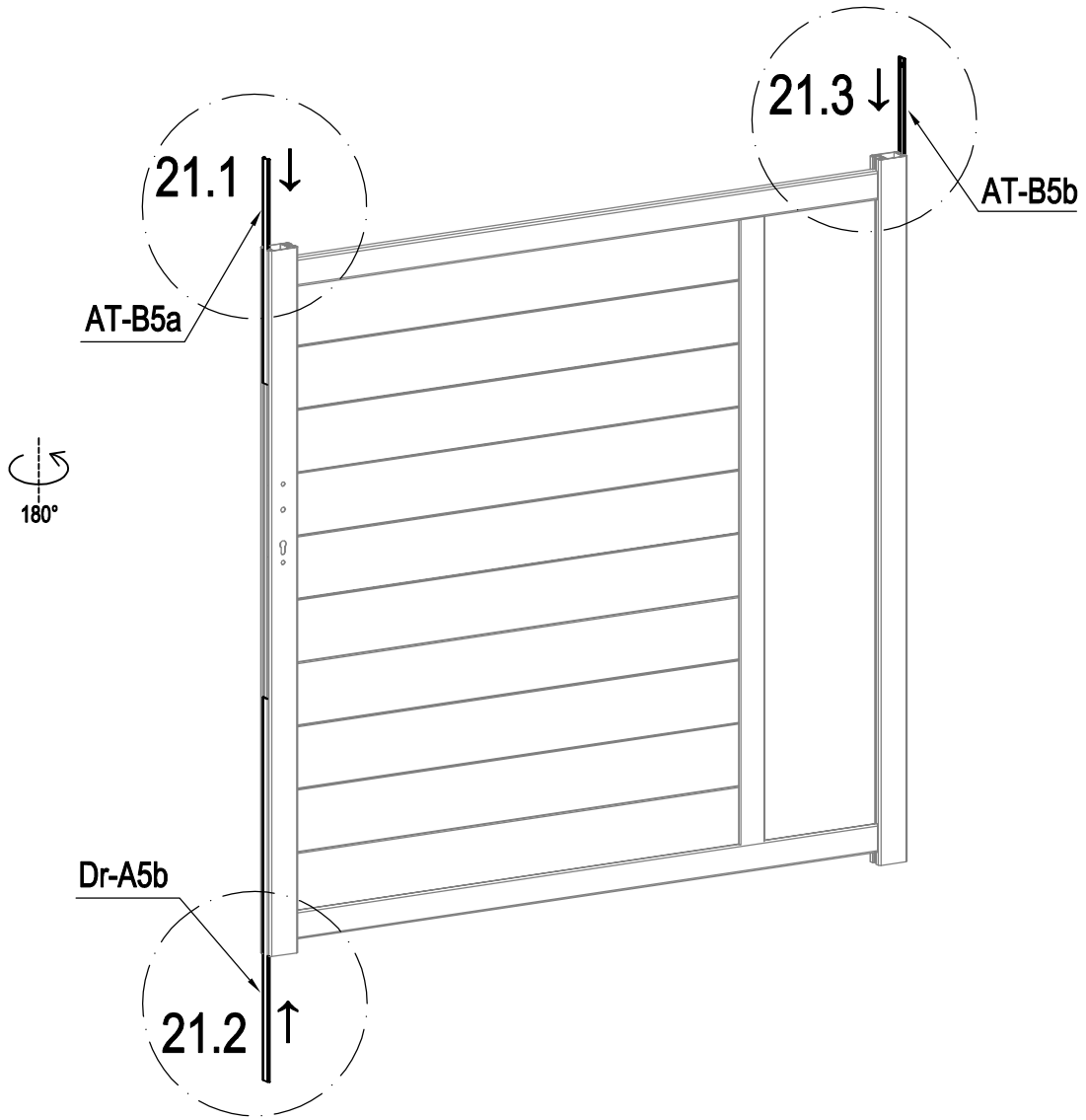

	AT-B11	2
---	--------	---



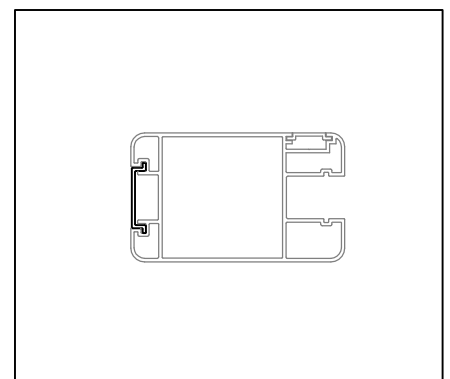

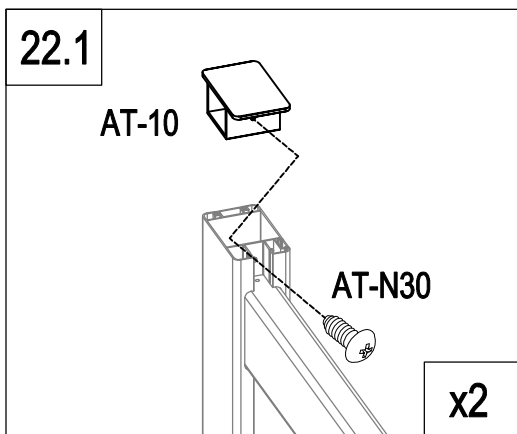
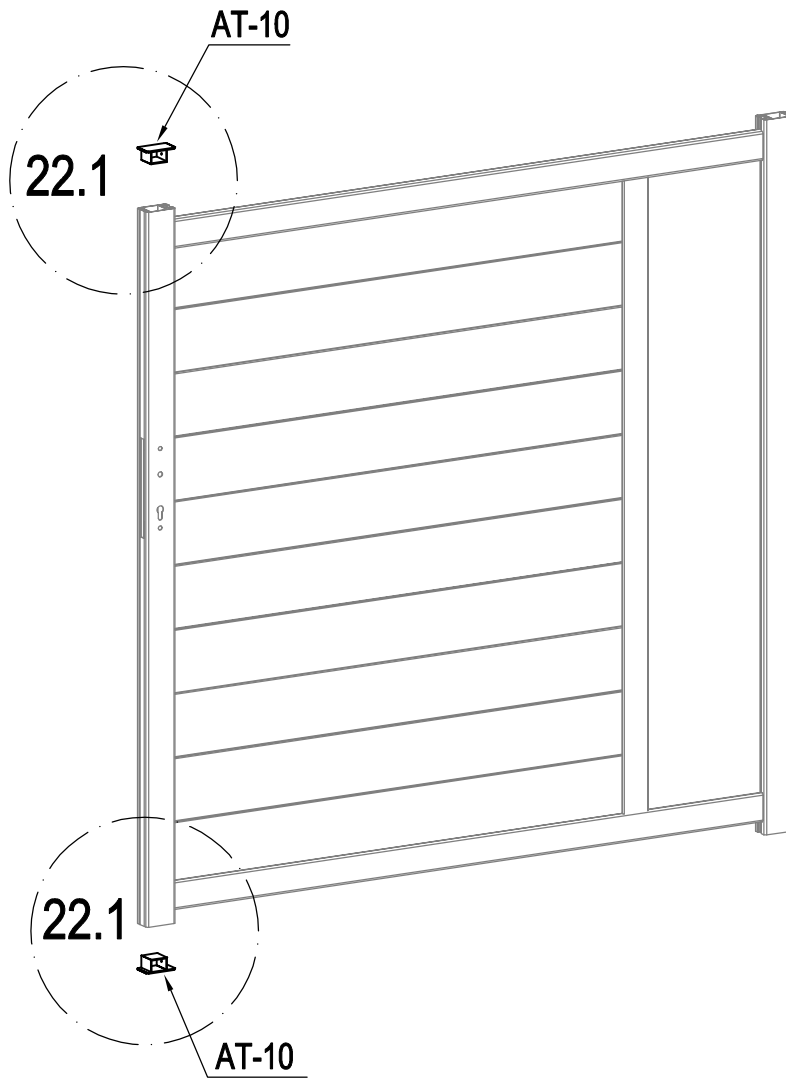
	AT-B5b	1
	AT-B5a	1
	Dr-A5b	1



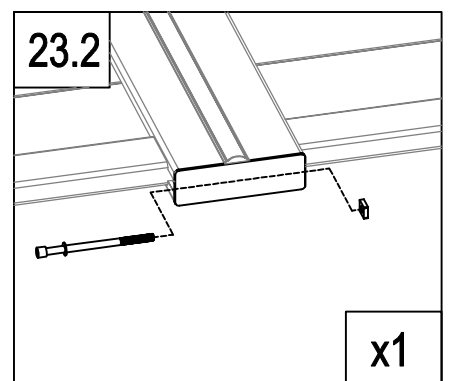
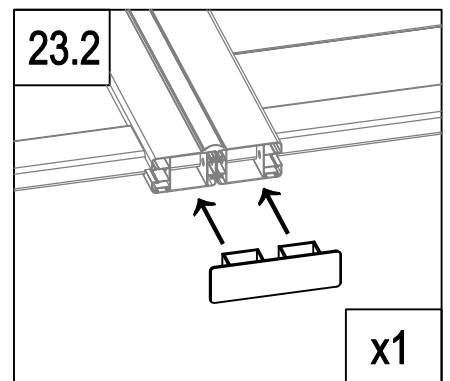
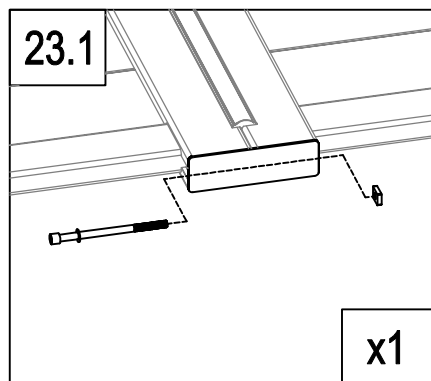
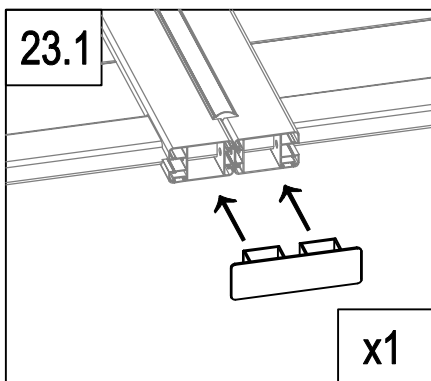
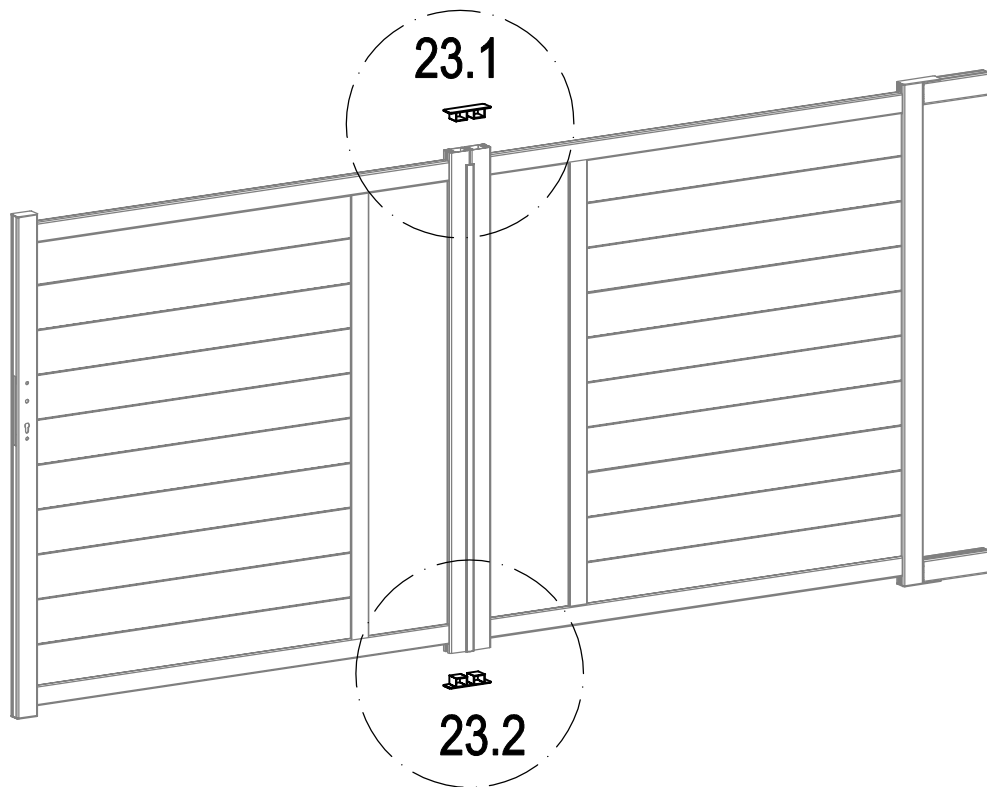

	AT-10	2
	AT-N30	2



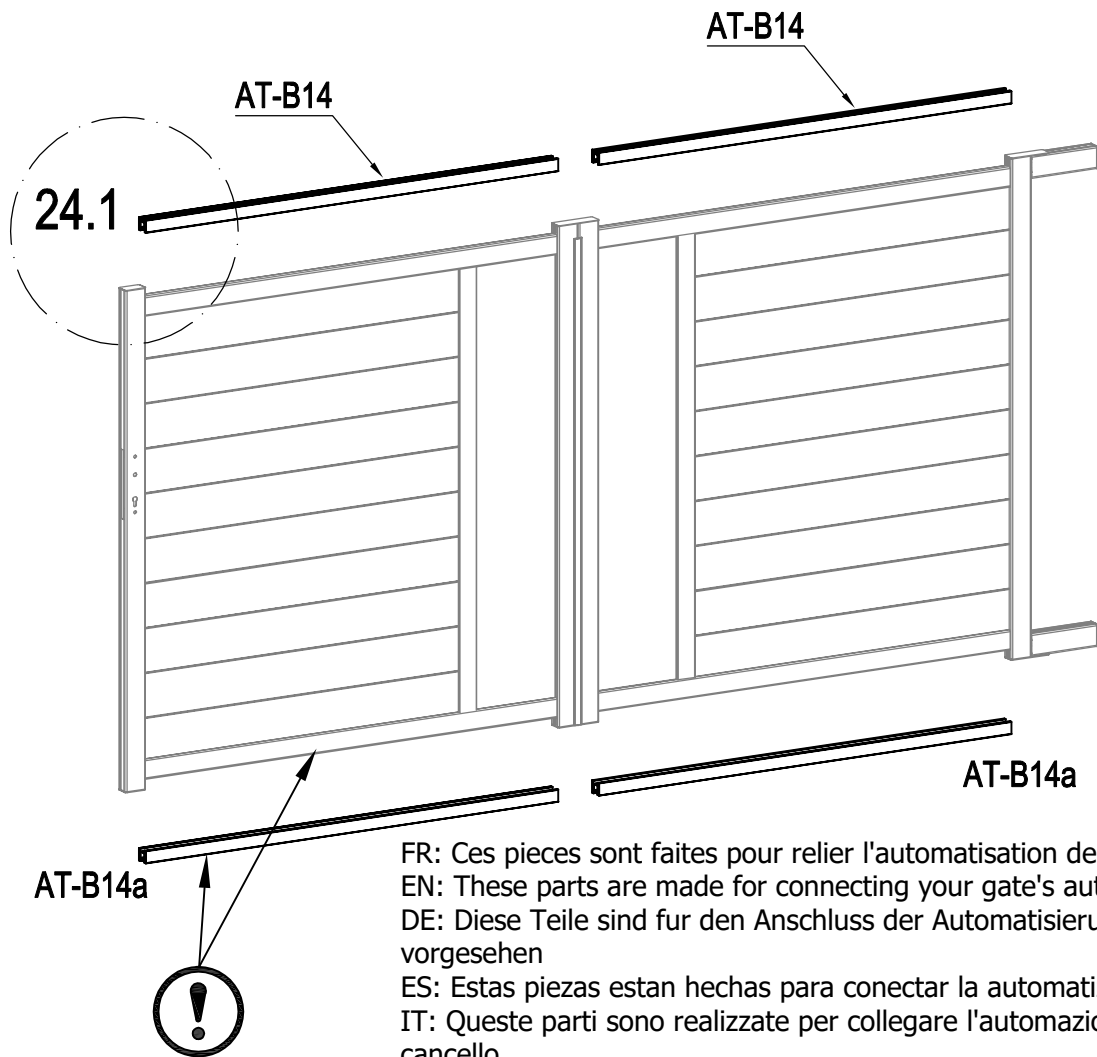

	AT-17	2
	AT-N33	2



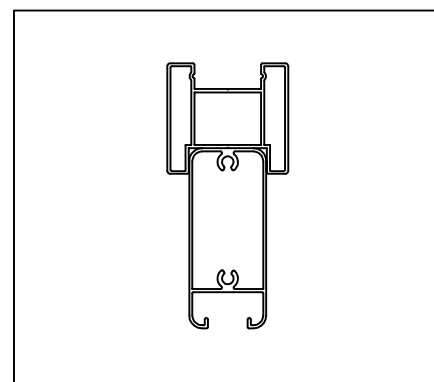
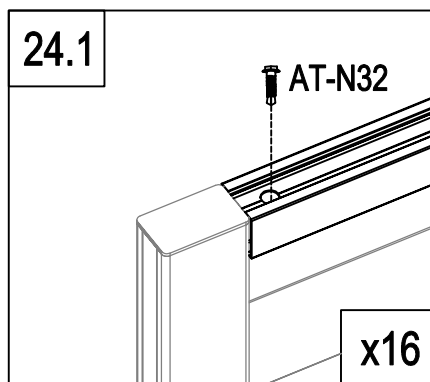
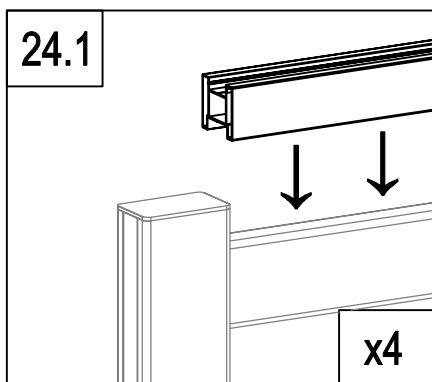



FR: Ces pieces sont faites pour relier l'automatisation de votre portail  
 EN: These parts are made for connecting your gate's automation  
 DE: Diese Teile sind für den Anschluss der Automatisierung Ihres Tores vorgesehen  
 ES: Estas piezas están hechas para conectar la automatización de su puerta  
 IT: Queste parti sono realizzate per collegare l'automazione del vostro cancello  
 NL: Deze onderdelen zijn gemaakt voor het aansluiten van de automatisering van uw poort  
 PT: Estas peças são feitas para conectar a automação do seu portão  
 PL: Te części są przeznaczone do podłączenia automatyki Twojej bramy



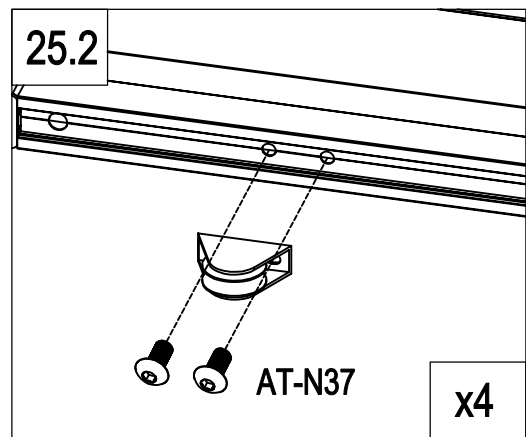
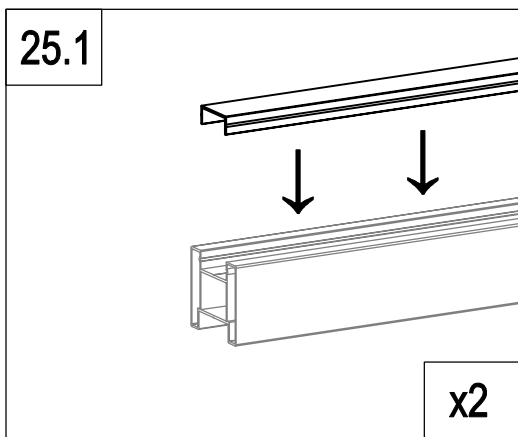
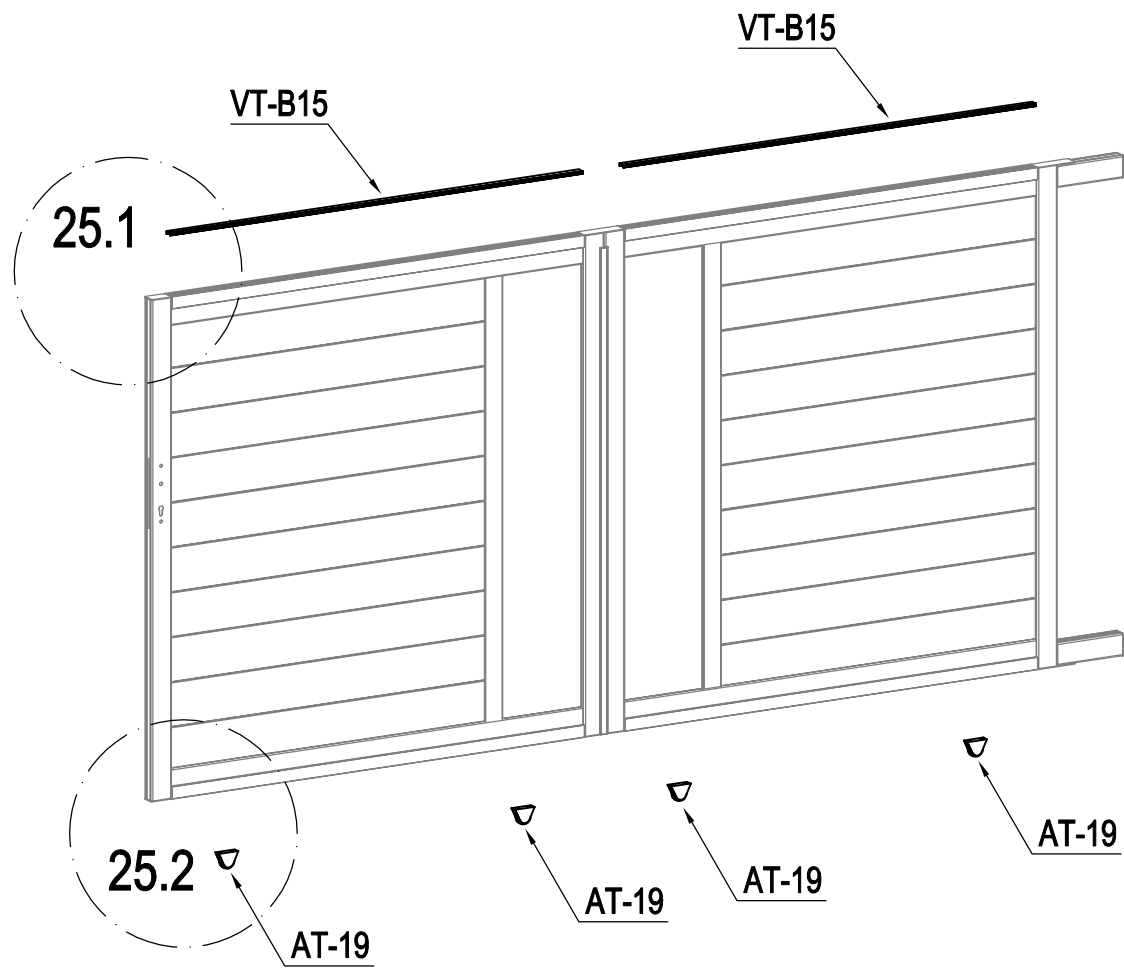

	AT-B14	2
	AT-B14a	2
	AT-N32	16



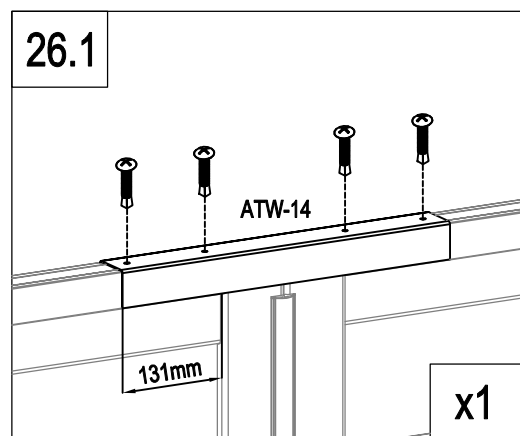
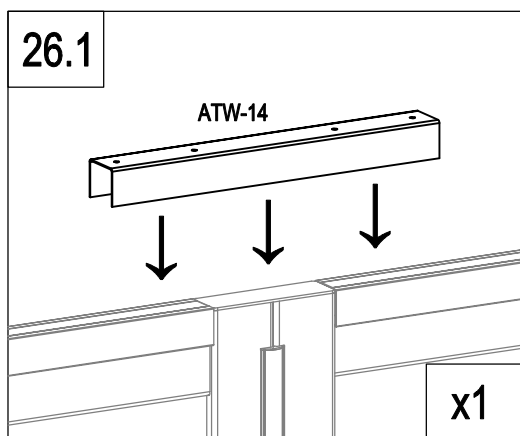
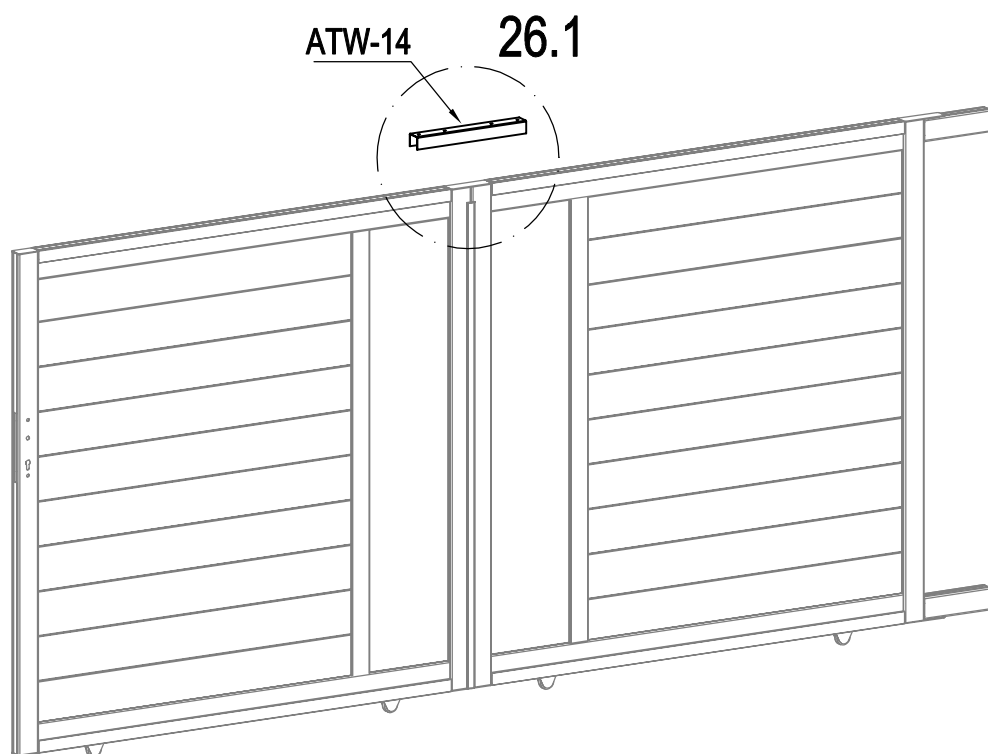

	VT-B15	2
	AT-19	4
	AT-N37	8



	ATW-14	1
	AT-N34	4

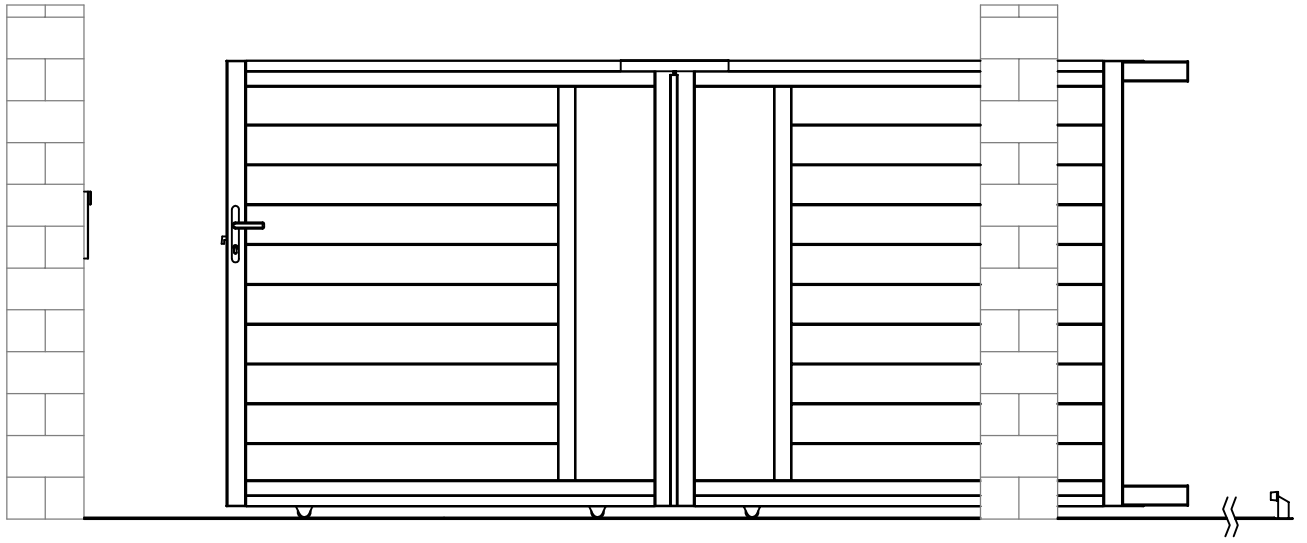

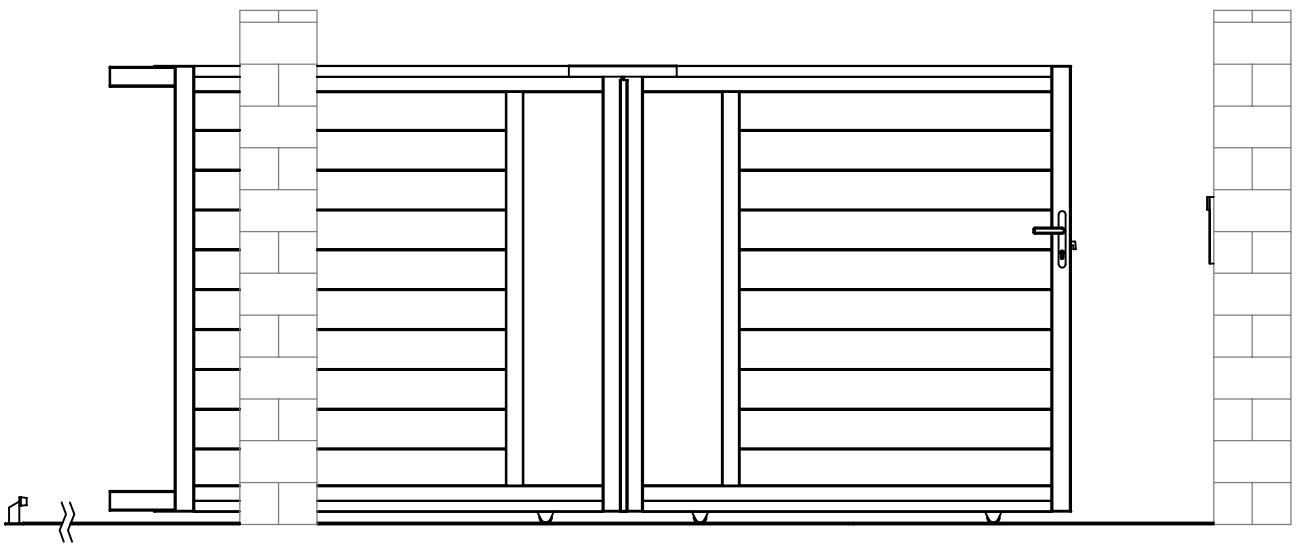

**L** : P27~32

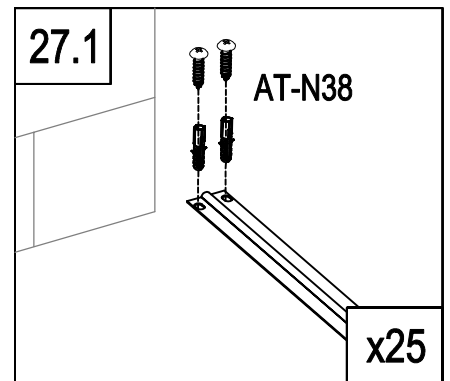
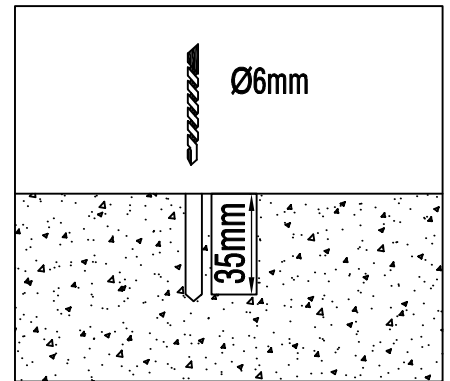
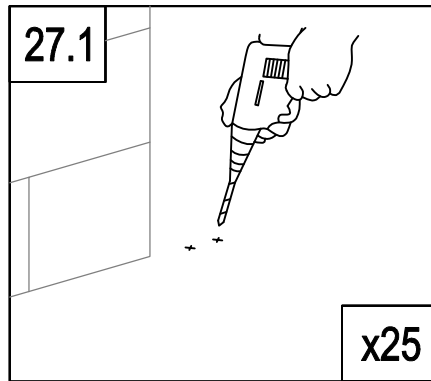
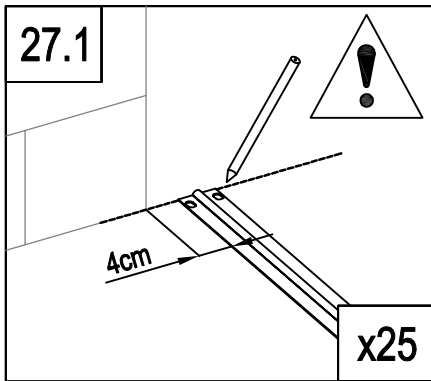
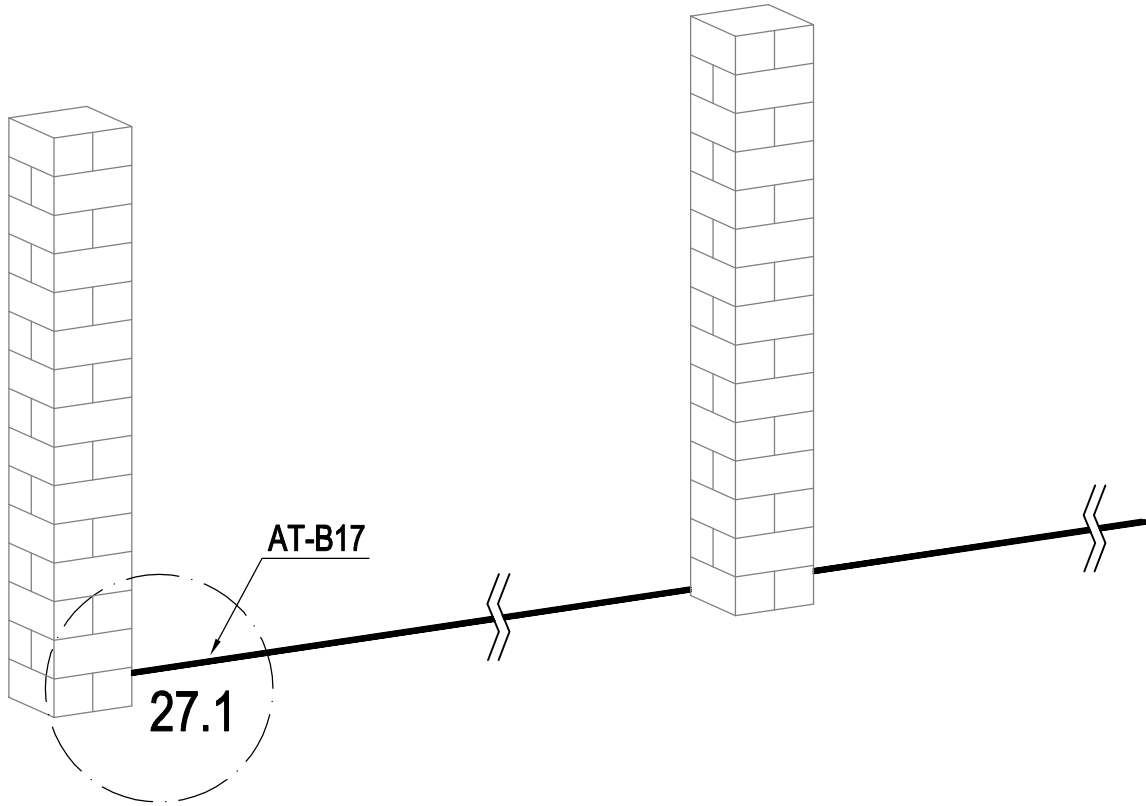

**R** : P33~38



	AT-B17	5
	AT-N38	50

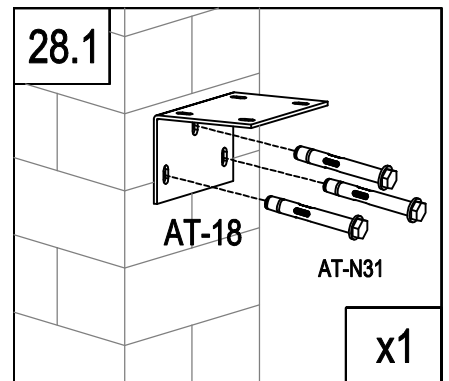
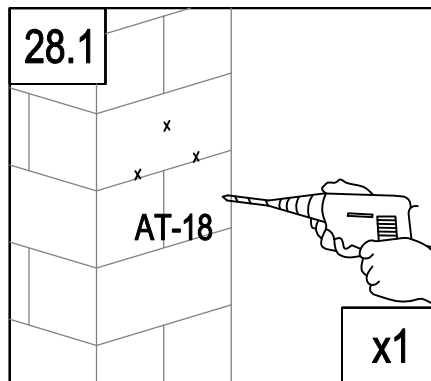
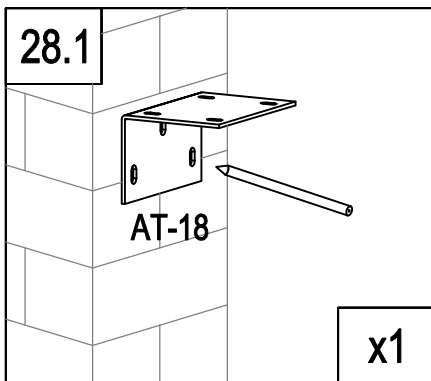
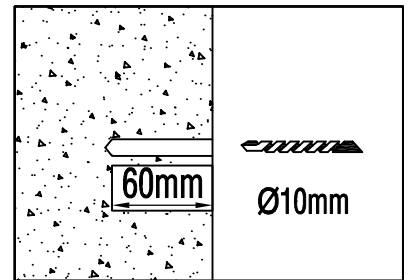
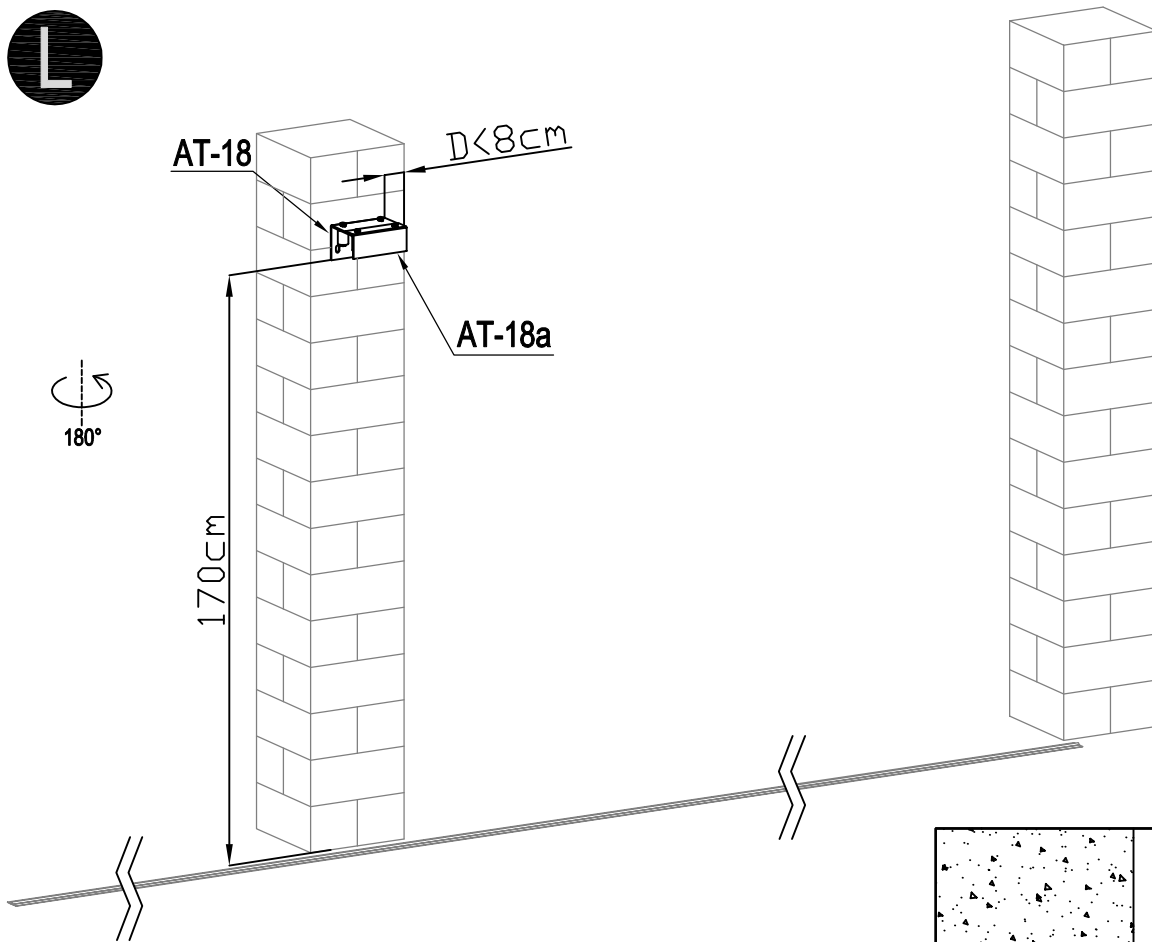

	AT-18	1
	AT-18a	1
	AT-20	4
	AT-N31	3

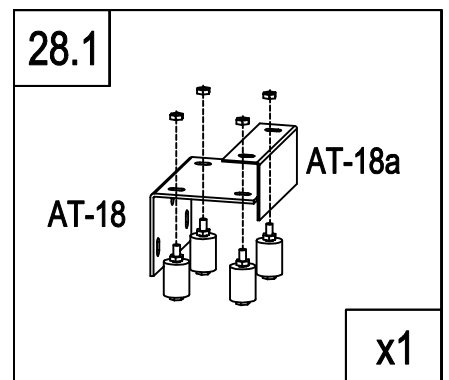
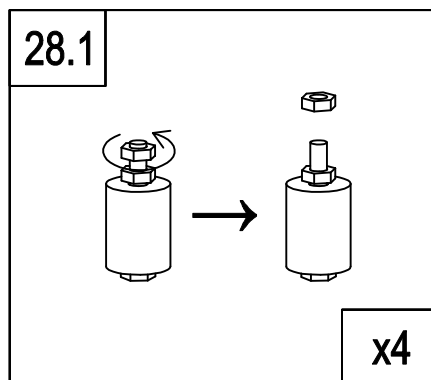

L

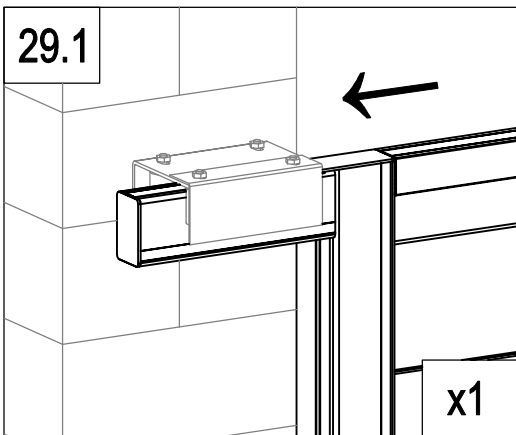
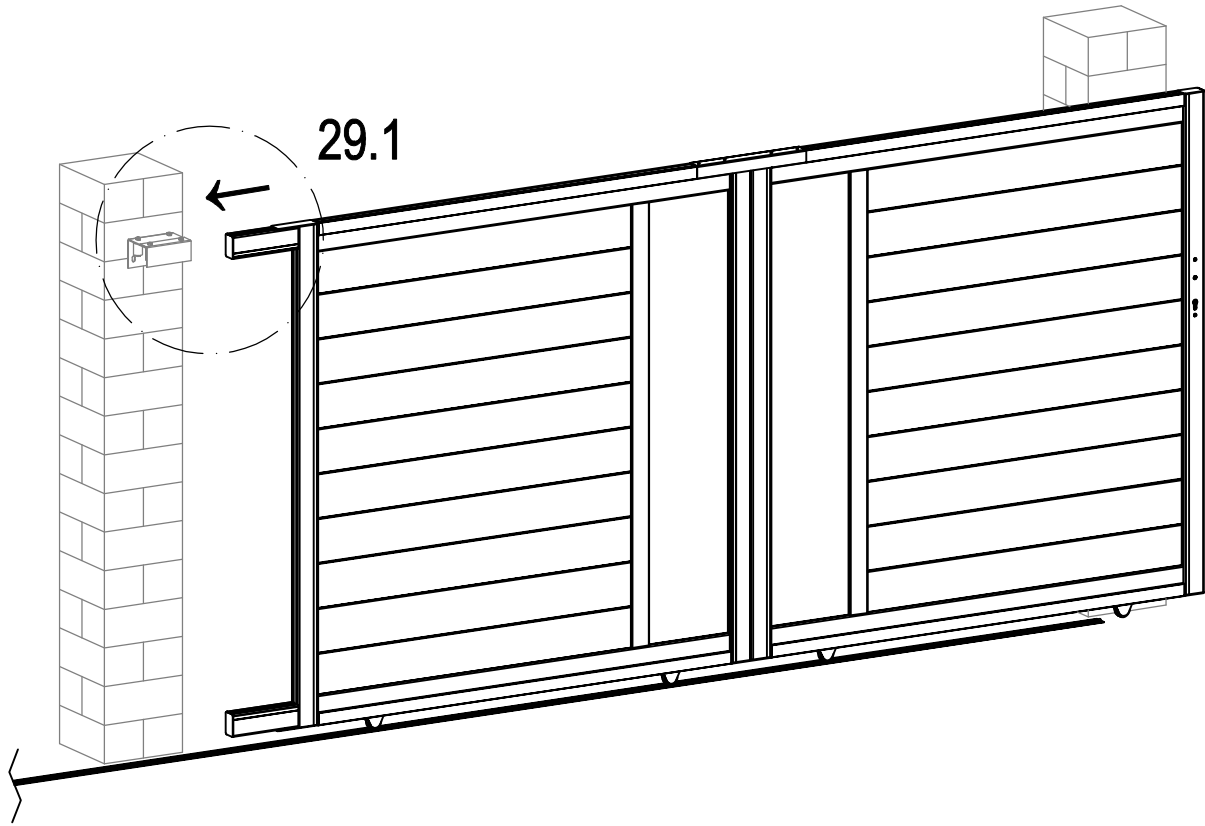

L

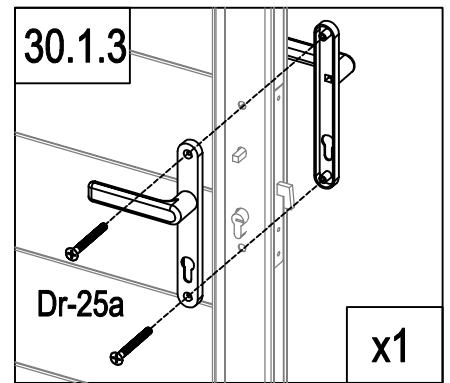
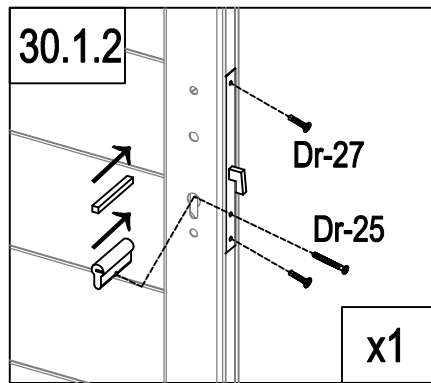
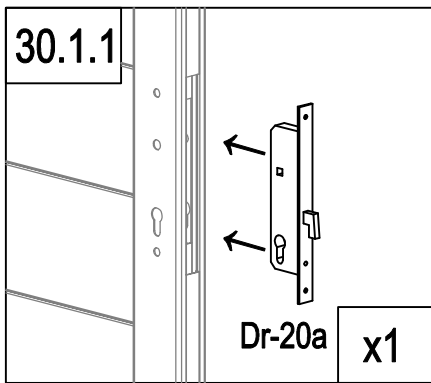
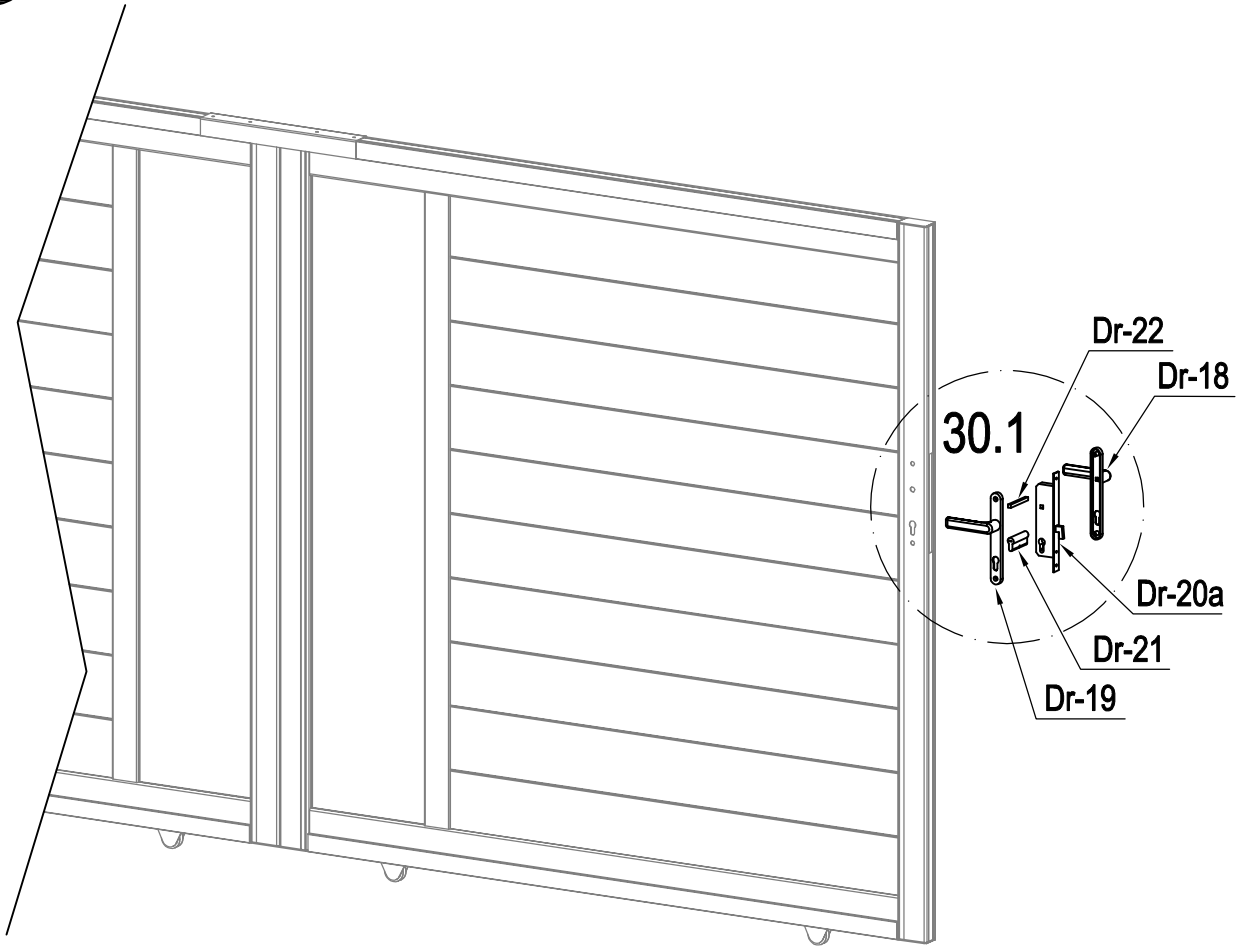

	Dr-20a	1
	Dr-21	1
	Dr-22	1
	Dr-25	1

	Dr-18	1
	Dr-19	1
	Dr-25a	2
	Dr-27	2

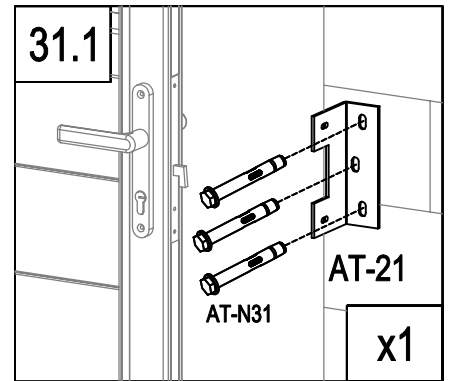
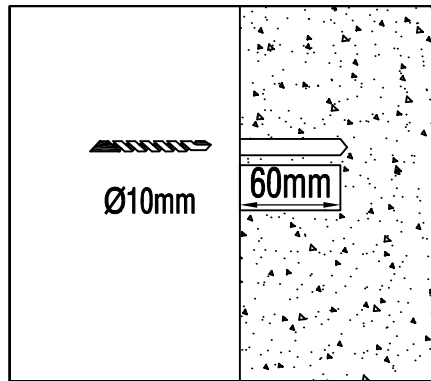
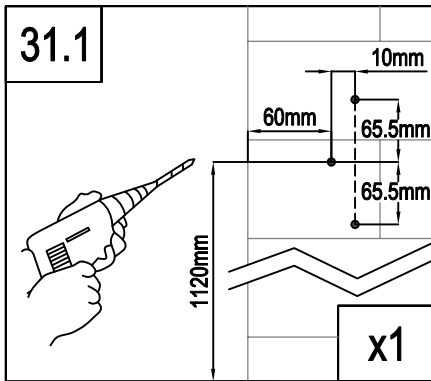
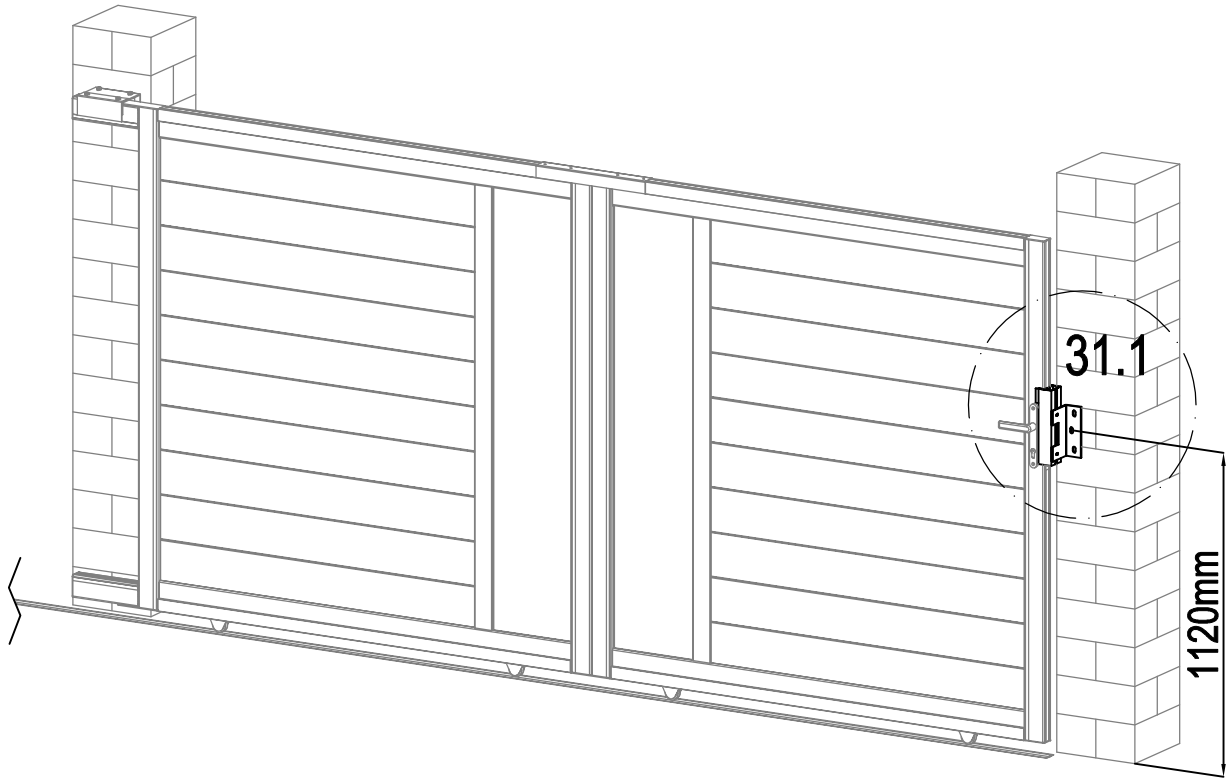

	AT-16	1
	AT-21	1
	AT-N36	2
	AT-N31	3
	AT-22J	3

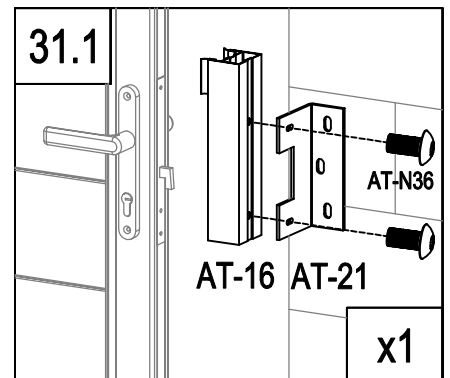
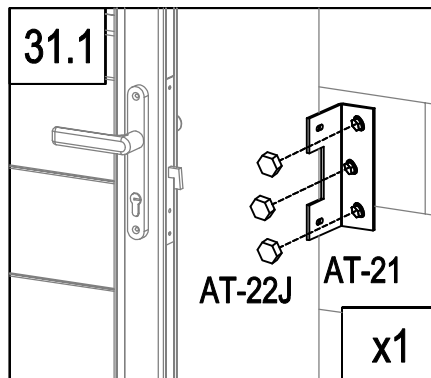



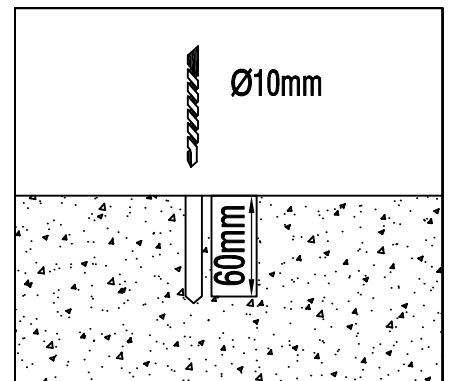
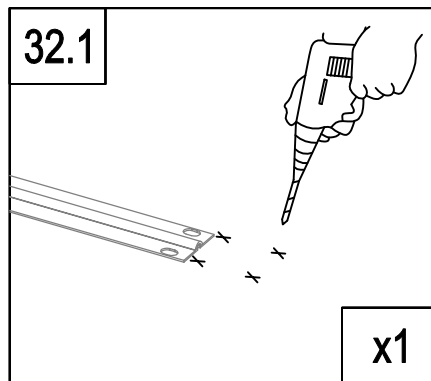
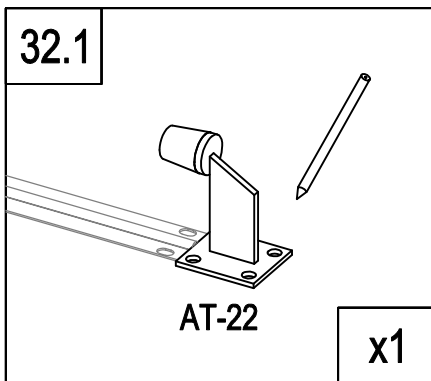
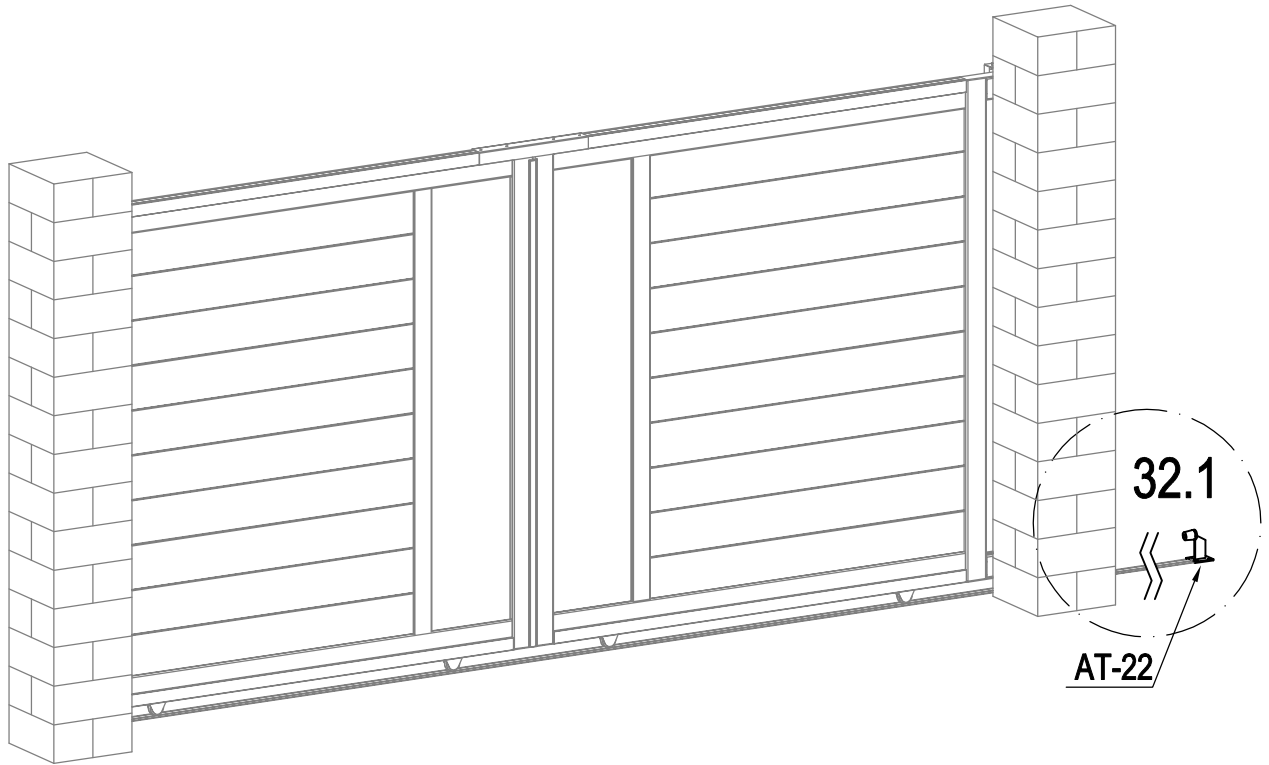

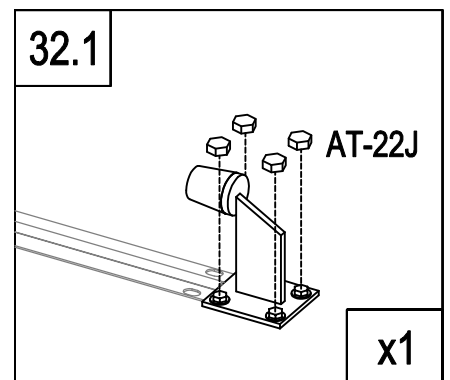
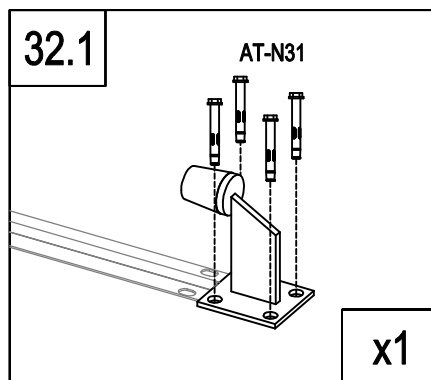

	AT-22	1
	AT-N31	4
	AT-22J	4

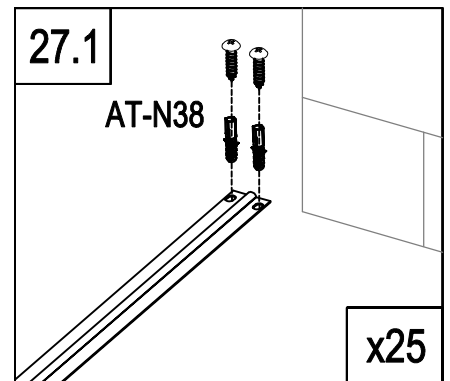
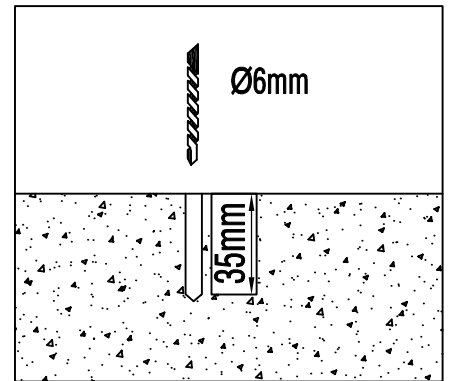
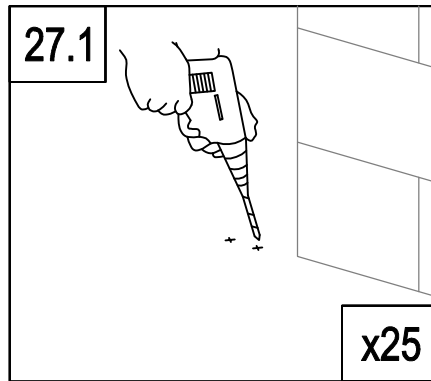
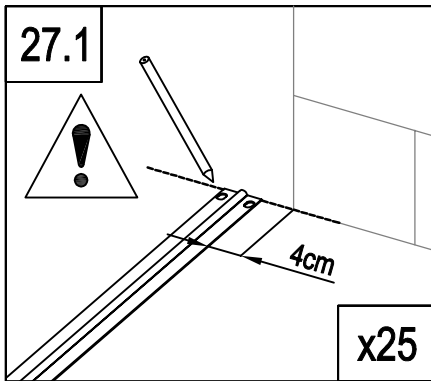
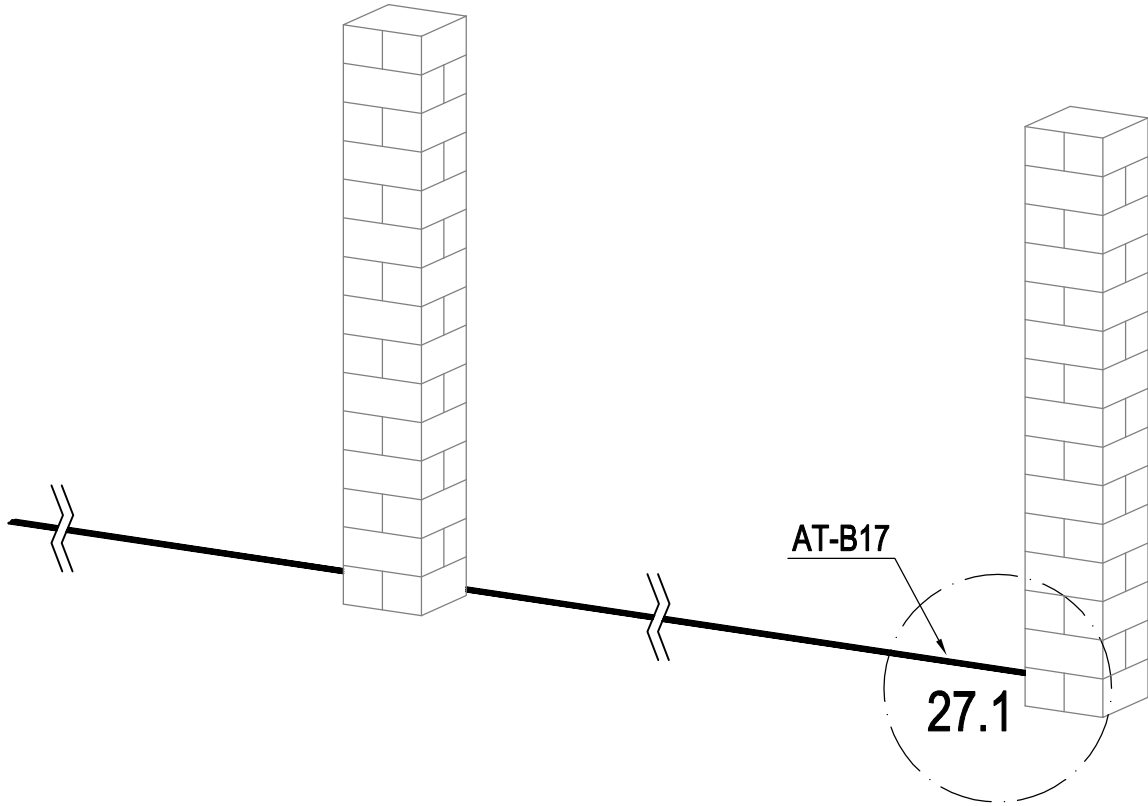



	AT-B17	5
	AT-N38	50

**R**

180°

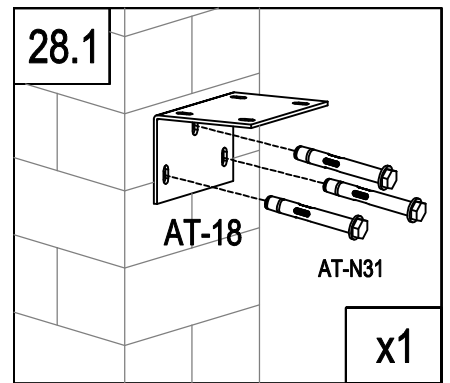
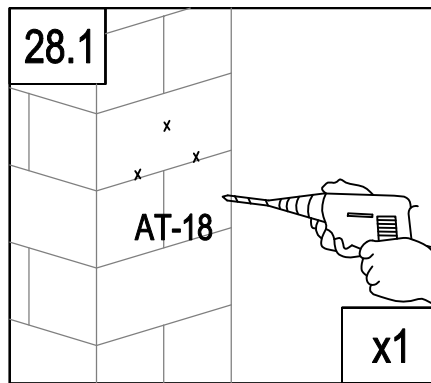
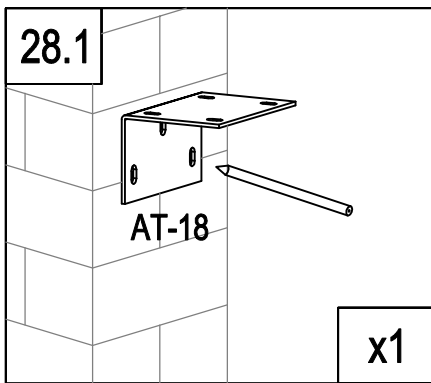
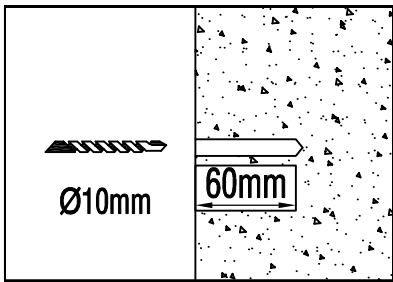
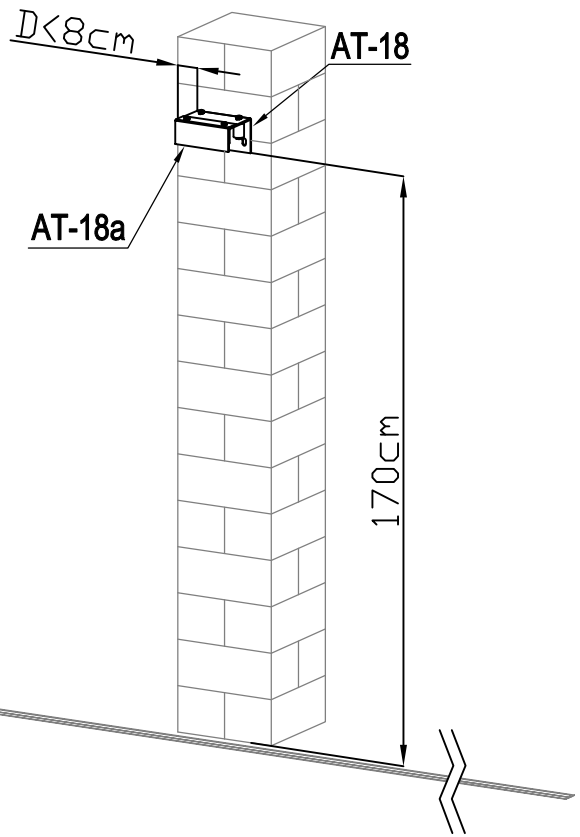
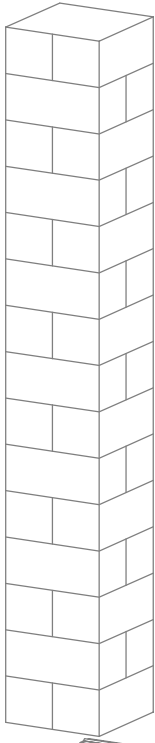

	AT-18	1
	AT-18a	1
	AT-20	4
	AT-N31	3

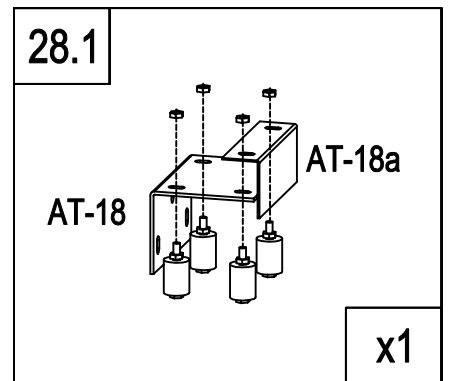
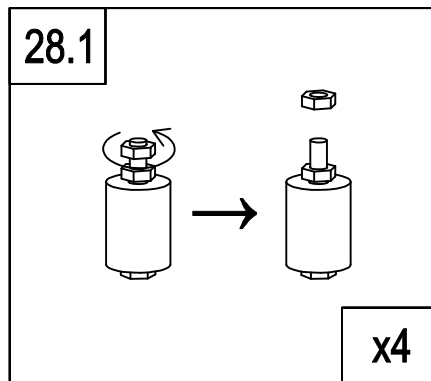

R

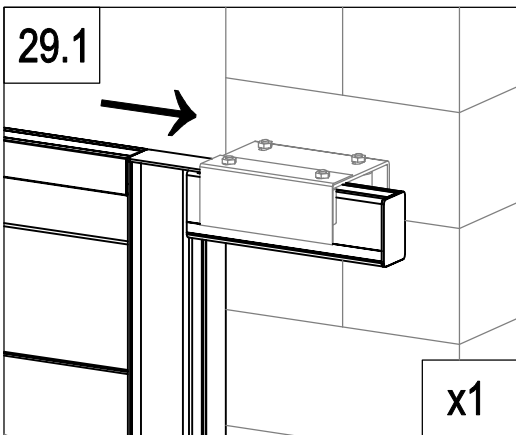
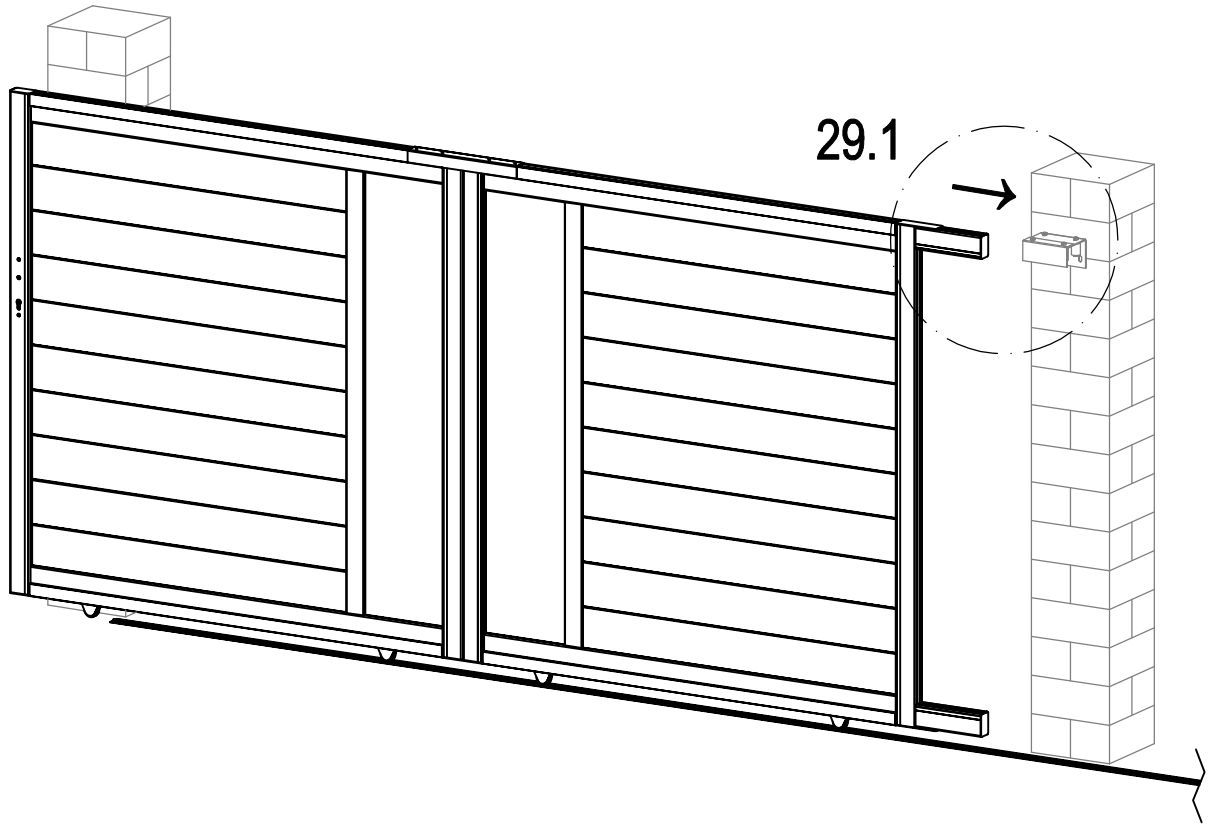

**R**

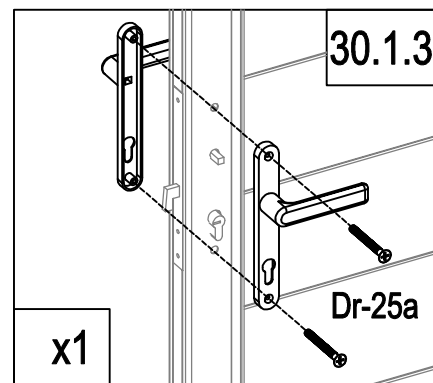
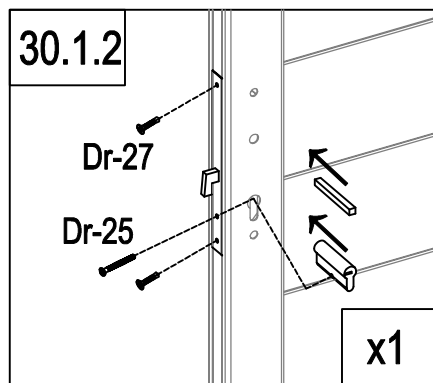
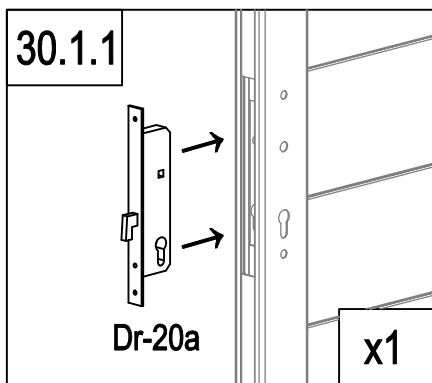
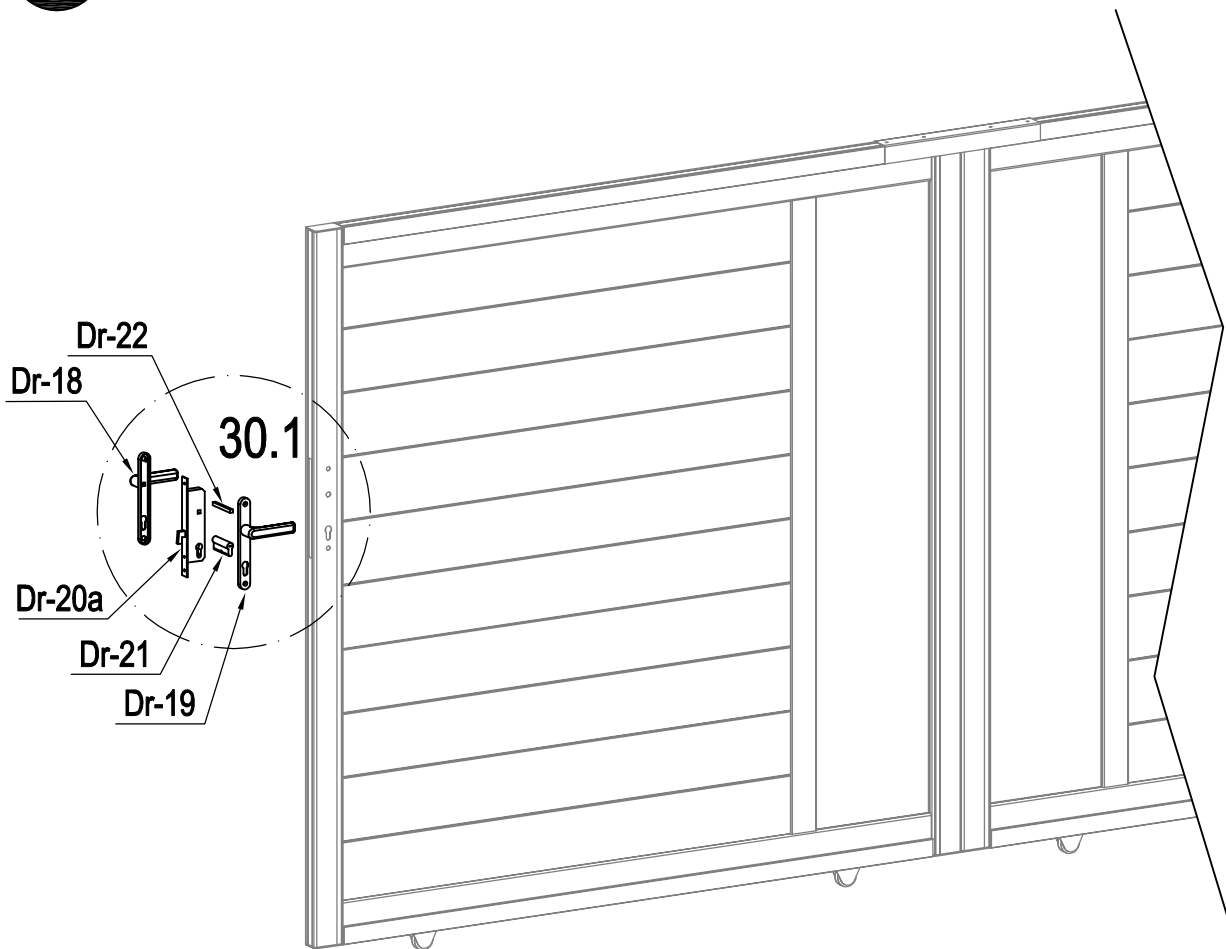

	<b>Dr-20a</b>	<b>1</b>
	<b>Dr-21</b>	<b>1</b>
	<b>Dr-22</b>	<b>1</b>
	<b>Dr-25</b>	<b>1</b>

	<b>Dr-18</b>	<b>1</b>
	<b>Dr-19</b>	<b>1</b>
	<b>Dr-25a</b>	<b>2</b>
	<b>Dr-27</b>	<b>2</b>

R

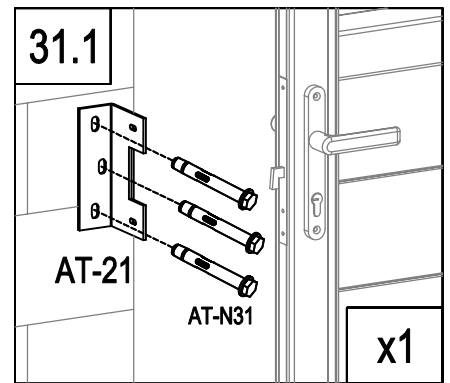
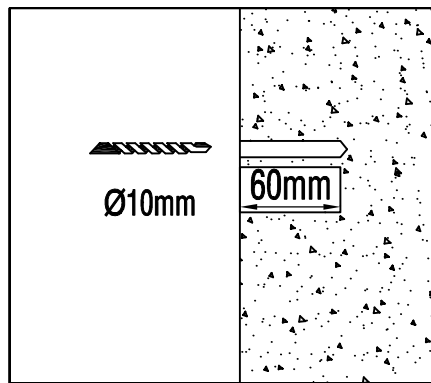
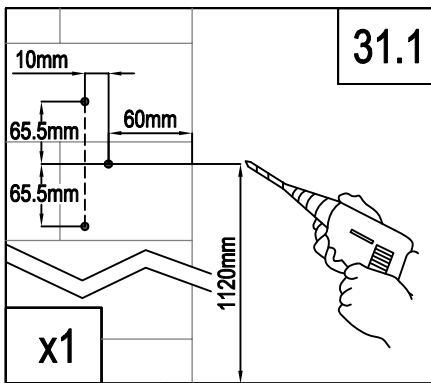
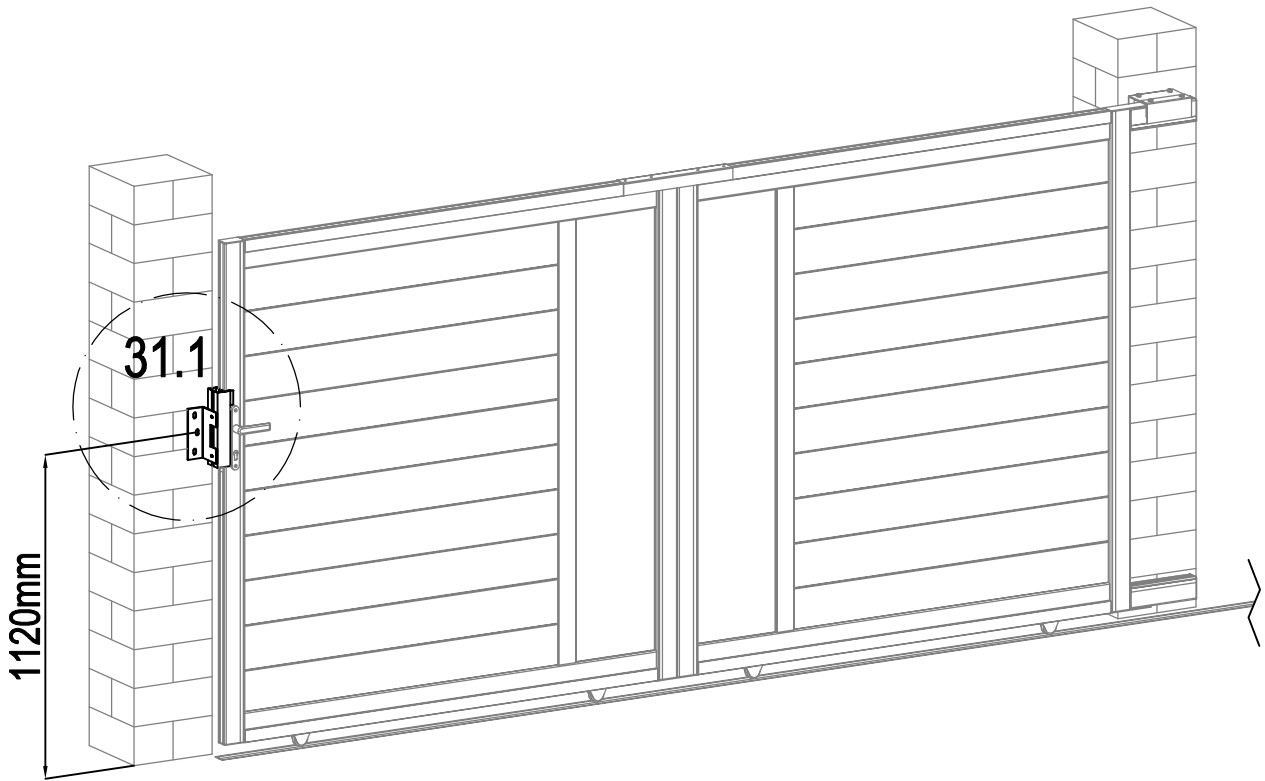

	AT-16	1
	AT-21	1
	AT-N36	2
	AT-N31	3
	AT-22J	3

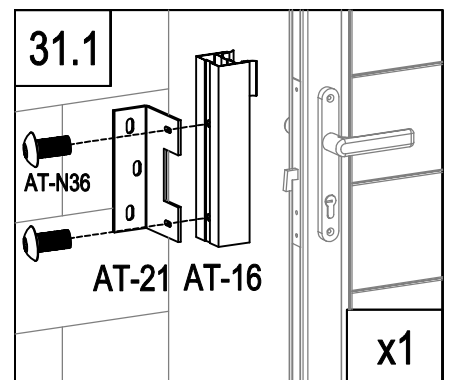
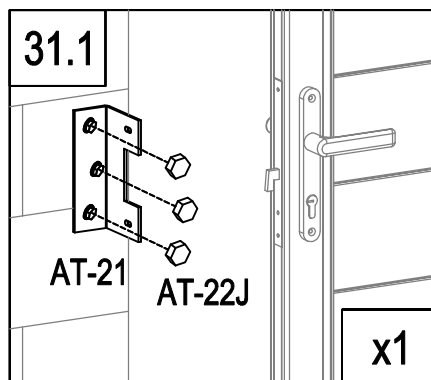

**R**

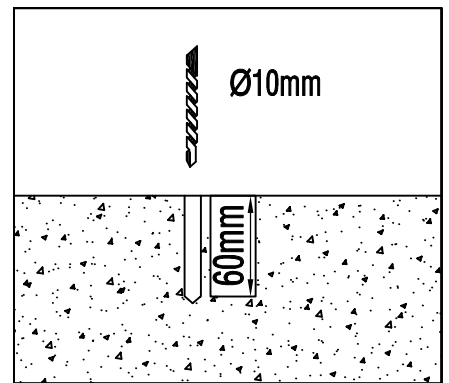
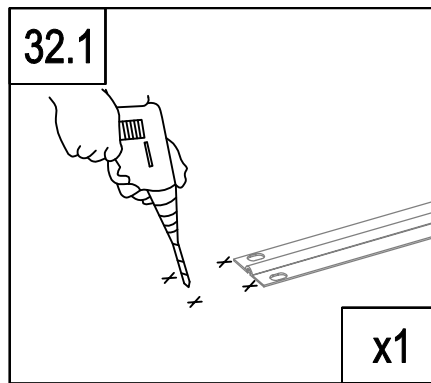
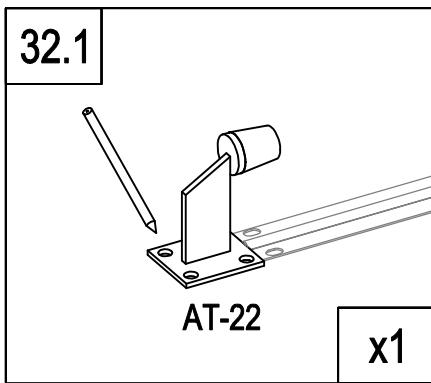
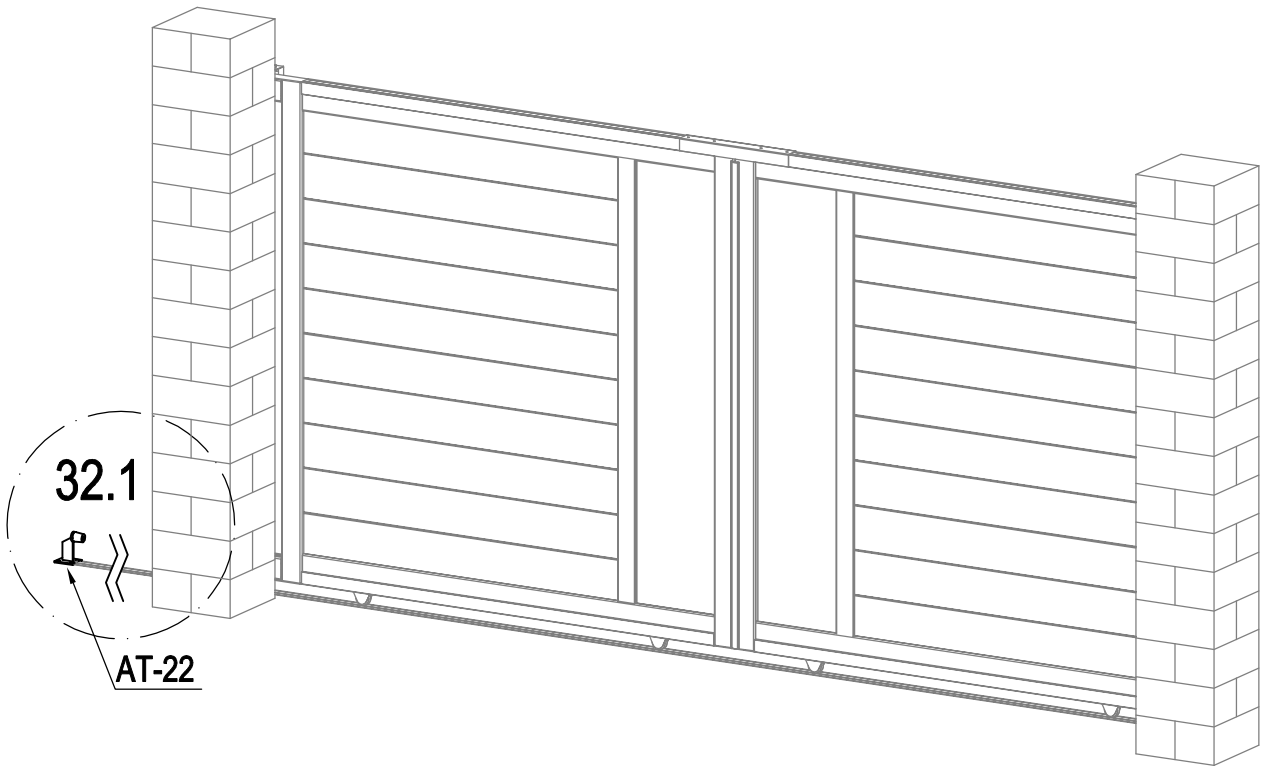

	AT-22	1
	AT-N31	4
	AT-22J	4

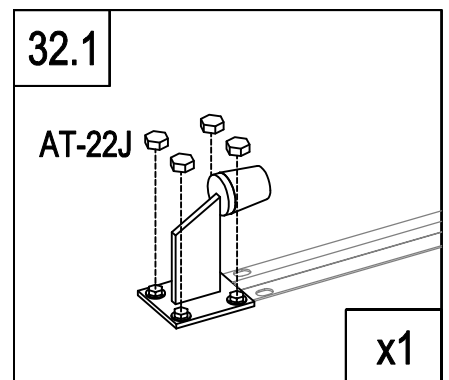
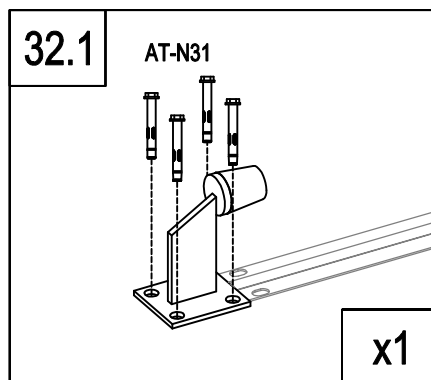



Vente-unique<sup>.com</sup>

VS-December-2022

Imported by - Importé par  
VENTE-UNIQUE.COM  
9 Rue Jacquart 93310 Le Pré-Saint-Gervais  
Made in China/ Fabriqué en Chine