

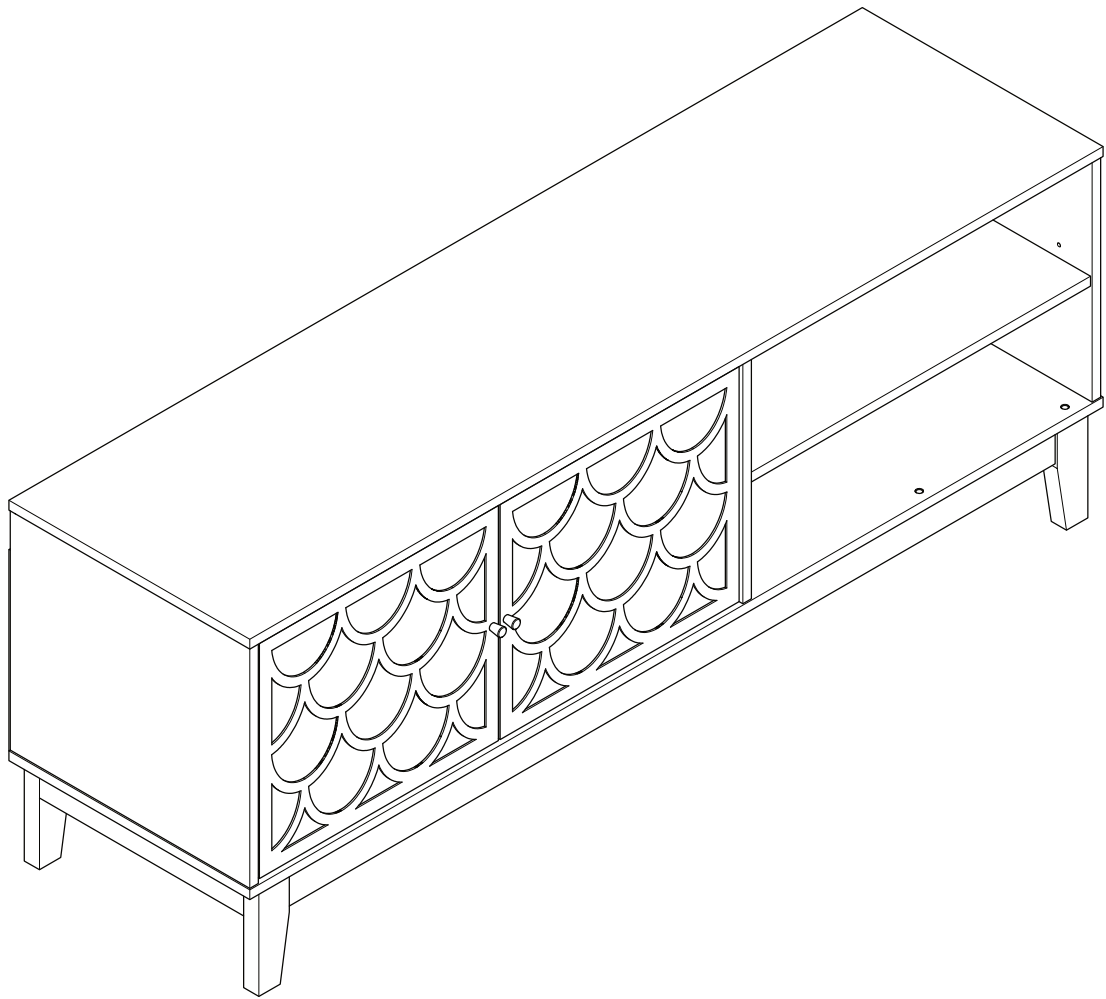



**ASSEMBLY INSTRUCTIONS / INSTRUCTIONS
D'ASSEMBLAGE / INSTRUCTIVO DE ARMADO**





FG-WH-PU-7-504-RN-UK

NOTES ON ASSEMBLY / NOTES POUR L'ASSEMBLAGE / NOTAS SOBRE EL ENSAMBLE

- To ensure ease of assembly read all instructions before assembly and follow step by step illustrations.
- Keep instructions for future use.
- Adult assembly required.  2 person required. 
- Due to the presence of small parts during assembly, keep out of reach of children until assembly is complete.

- Pour assurer l'assemblage facile veuillez lire toutes les instructions avant l'assemblage et veuillez suivre les illustrations pour chaque etapes.
- Veuillez garder ces instructions pour l'usage ulterieur.
- Assemblage requis pas un adulte.  2 personnes requises. 
- Due a la presence de petite pieces durant l'assemblage, veuillez garder hors de porter des enfants jusqu'a ce que l'assemblage soit completer.

- Para garantizar la facilidad de ensamble lea las instrucciones antes de iniciar y siga paso a paso las ilustraciones.
- Guarde las instrucciones para futuras referencias.
- El ensamble requiere de un adulto.  2 personas requeridas. 
- Debido a que hay piezas pequeñas, mantenga fuera del alcance a los niños durante el ensamble, hasta que haya terminado.

MAINTENANCE TIPS / CONSEILS D'ENTRETIEN / CONSEJOS DE MANUTENIMIENTO

- Never let liquids or damp cloths sit on this furniture.
- Never use chemical cleaning products. They can damage the finish. For cleaning, use only a slightly damp cloth and wipe dry.
- To avoid dulling of the finish, do not place furniture in direct sunlight.
- Do not put plastic or rubber rings under appliances. Use cloth of felt protectors.
- To clean, use a soft or slightly damp cloth, then wipe with a clean, dry cloth.

- Ne jamais laisser de liquide ou linge humide sur le meuble.
- Ne jamais utiliser de nettoyeurs à base de produits chimiques, cela va endommager le fini. Utiliser seulement un linge légèrement humide.
- Ne pas placer le meuble directement au soleil pour prévenir le ternissement.
- Évitez de déposer des appareils avec des rondelles de plastique ou de caoutchouc. Utilisez un protecteur en tissu ou en feutre.
- Pour nettoyer, utilisez un linge doux ou légèrement humecté. Essayez par la suite avec un linge propre et sec.

- Nunca deje un líquido o un trapo húmedo sobre el mueble.
- Nunca utilice limpiadores a base de químicos, estos dañaran le acabado. Use sólo un paño húmedo.
- No esponga el mueble directamente al sol para prevenir empañamiento.
- Evite apoyar aparatos con redondeles de plástico o de goma. Utilizar un protector de tela o de fieltro.
- Para limpiar, utilice un trapo suave o ligeramente humedecido. Seque luego con un trapo limpio y seco.

WARNING AVERTISSEMENT / ADVERTENCIA

Please use your furniture correctly and safely. Improper use can cause safety hazards, or damage to your furniture or household items.

Serious or fatal crushing injuries can occur from furniture tip-over.

To help prevent tip-over:

- It is important to place the safety bracket included.
- Place heaviest items in the lowest storage space.
- Never allow children to climb or hang on drawers, doors, or shelves.
- Never open more than one drawer at a time.
- If a heavy object is placed on top or inside the furniture, consider this risk.

Use of tip-over restraints reduce, but does not eliminate, the risk of tip-over.

Prière d'utiliser le mobilier à bon escient et avec prudence. Une mauvaise utilisation peut être à l'origine de risques d'accident ou peut endommager le mobilier et les articles ménagers.

Des blessures graves ou fatales peuvent résulter de basculement du meuble.

Afin de prévenir le basculement :

- Il est important d'installer le crochet de sécurité inclus.
- Placer les items les plus lourds dans les espaces de rangement du bas.
- Ne jamais laisser un enfant grimper sur les tiroirs, les portes et les tablettes ou s'accrocher à ceux-ci.
- Ne jamais ouvrir plus d'un tiroir à la fois.
- Si un objet lourd est placé sur l'unité ou à l'intérieur, considérez le risque de basculement.

L'utilisation de dispositif antibasculement ne peut que réduire les risques de basculement, sans les éliminer

Por favor use el mobiliario correcta y seguramente. El mal uso puede causar riesgos de seguridad o daño a las unidades o artículos domésticos.

El vuelco del mueble puede ser causa de lesiones graves o de un aplastamiento fatal.

Para evitar la volcadura:

- Es importante instalar el gancho de seguridad.
- Ponga las cosas pesadas en los compartimentos más bajos.
- Nunca permita que un niño se suba o se cuelgue en cajones, puertas o estantes.
- Nunca abra más de un cajón a la vez.
- Si un objeto pesado esta colocado dentro o sobre el mueble, considere el riesgo de que se puede voltear.

El uso de sujetadores para evitar el vuelco sólo puede disminuir el riesgo de un vuelco, pero no lo elimina.

MINIFIX CAM & MINIFIX BOLT & WOOD DOWEL
CAMÉRA MINIFIX & BOULON MINIFIX & CHEVILLE BOIS
CÁMARA MINIFIX & PERNO MINIFIX & PASADOR DE MADERA

MINIFIX BOLT
BOULON MINIFIX
PERNO MINIFIX

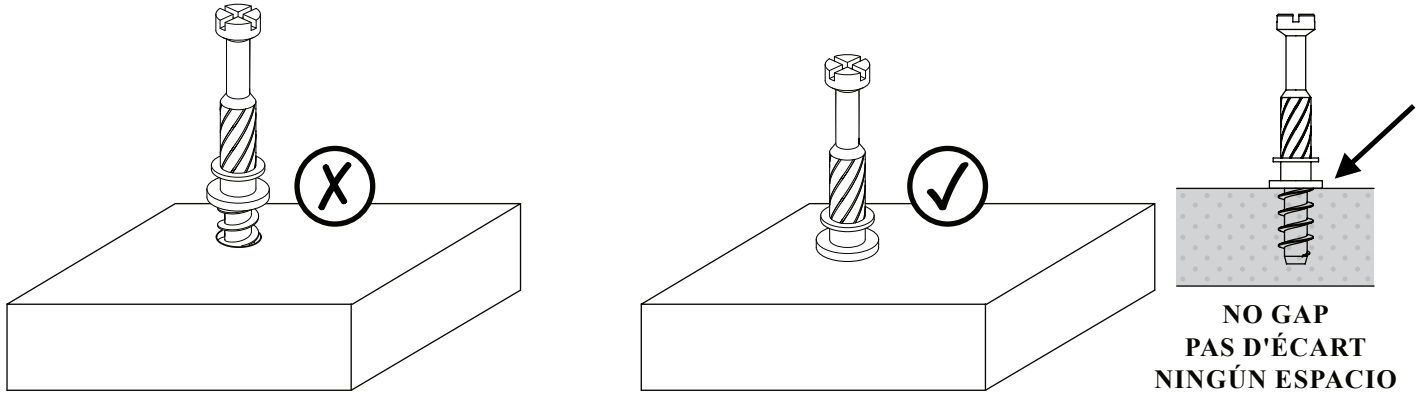

MINIFIX CAM
CAMÉRA MINIFIX
CÁMARA MINIFIX

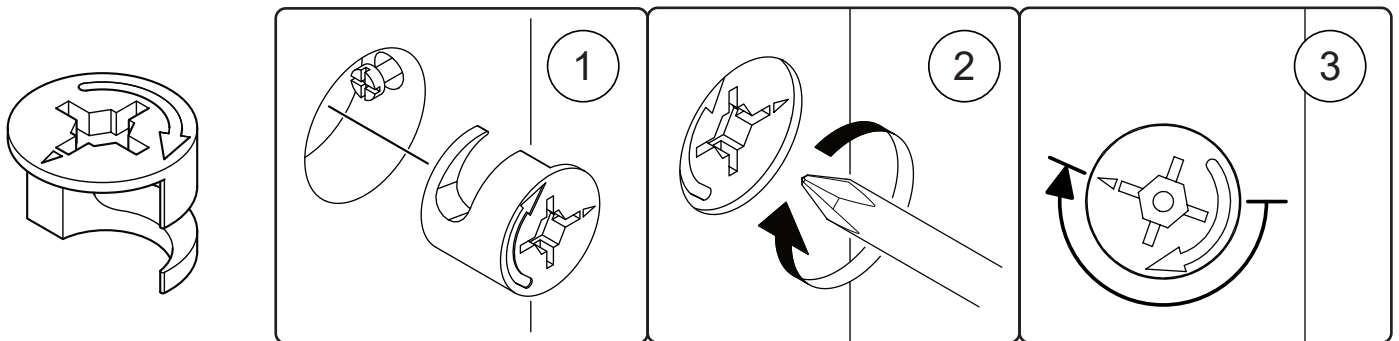

WOOD DOWEL
CHEVILLE BOIS
PASADOR DE MADERA

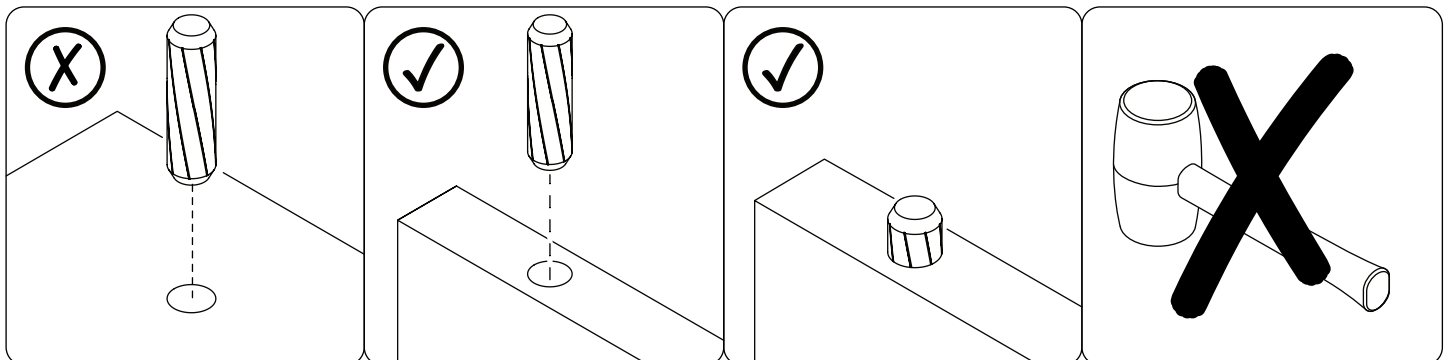

SPECIAL TIPS FOR DOOR ALIGNMENT

CONSEJOS ESPECIALES PARA LA ALINEACIÓN DE PUERTAS

CONSEILS SPÉCIAUX POUR L'ALIGNEMENT DES PORTES

- A. Lateral adjustment (Moving door left-right) by screw adjusting
 Ajuste lateral (Puerta móvil de izquierda a derecha) mediante tornillo de ajuste
 Réglage latéral (porte mobile gauche-droite) par réglage à vis

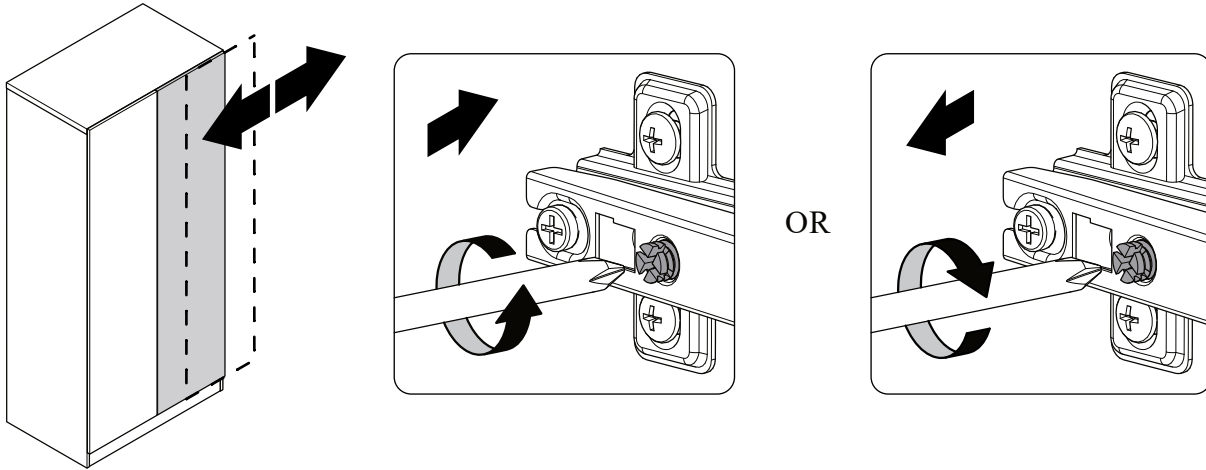

- B. Vertical adjustment (Moving door up-down) via the slot on the mounting plate
 Ajuste vertical (Puerta móvil arriba-abajo) a través de la ranura en la placa de montaje
 Réglage vertical (porte mobile de haut en bas) via la fente sur la plaque de montage

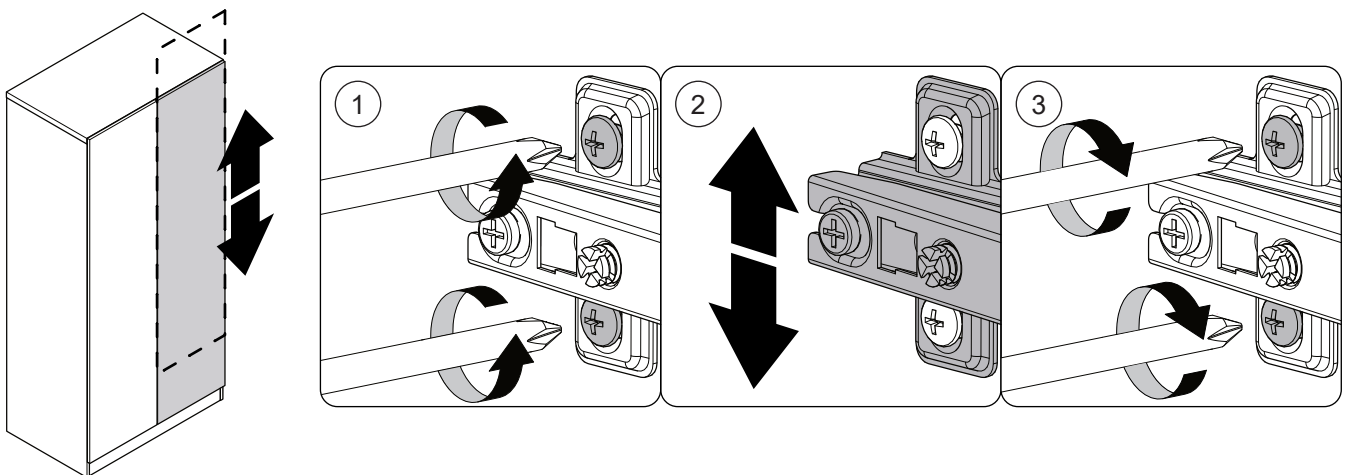



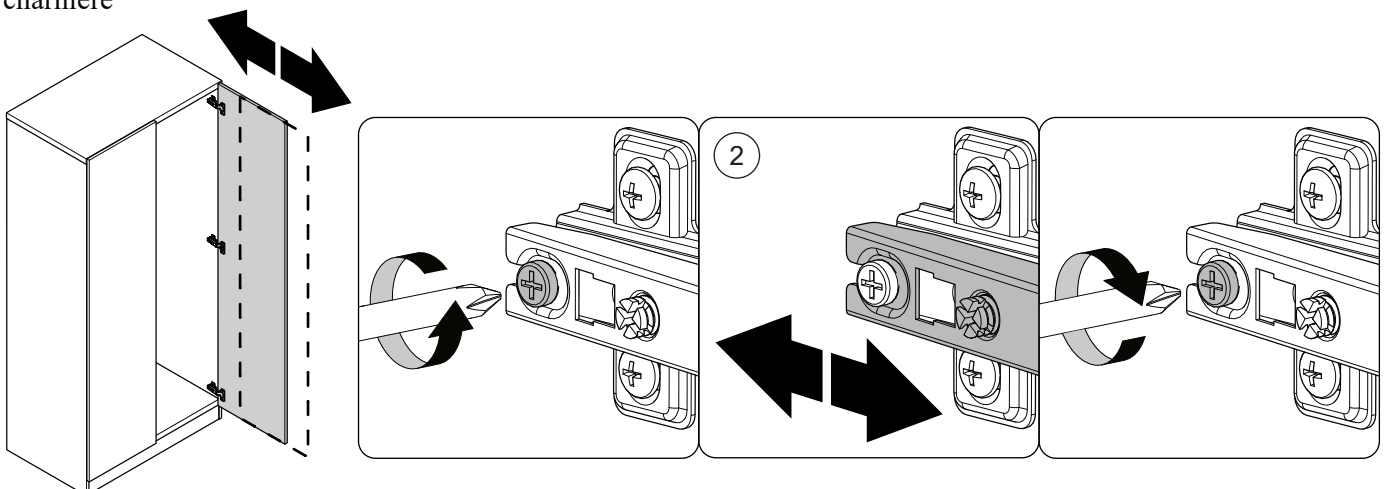

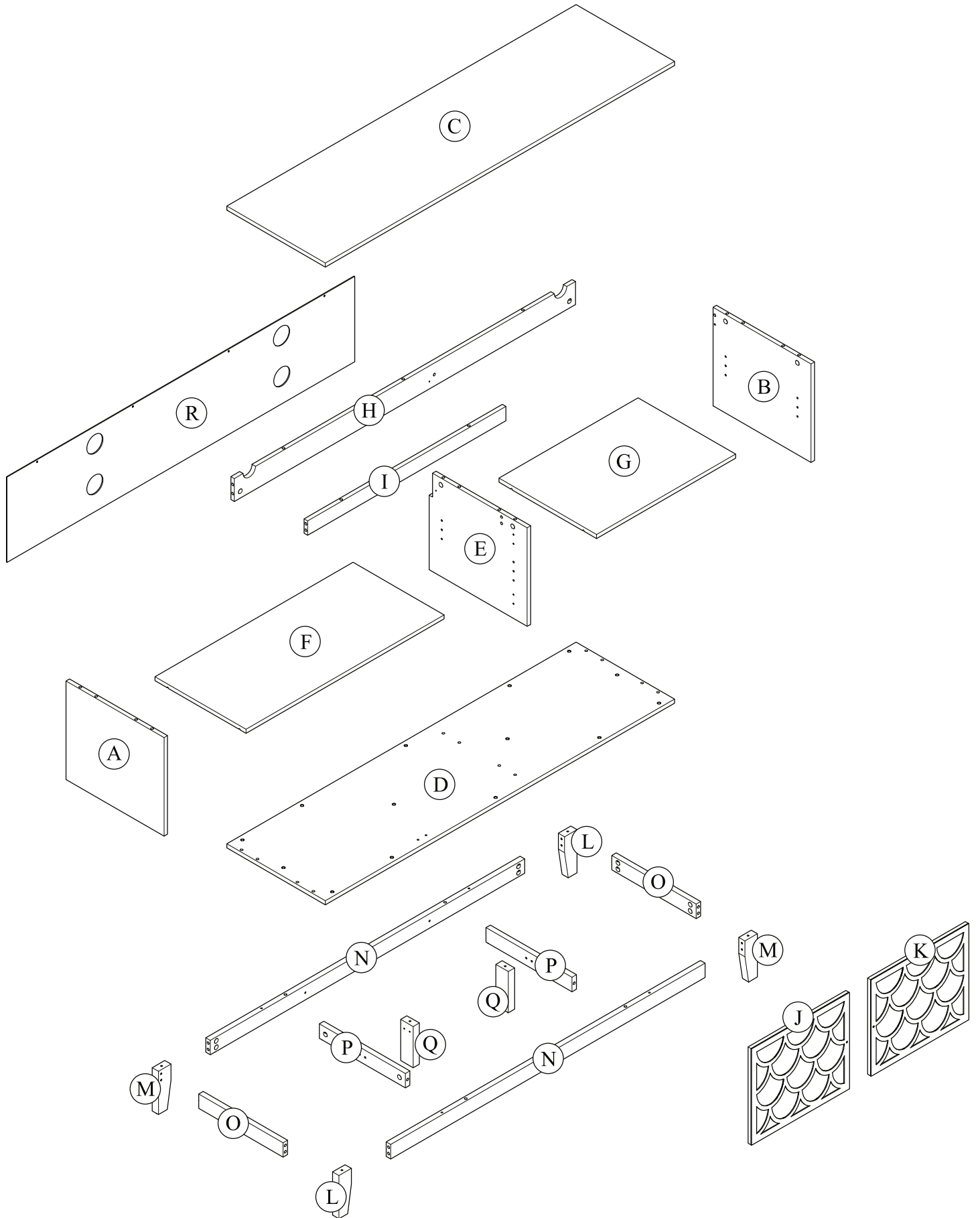











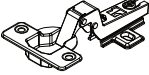

- C. Front-to-back adjustment (Spacing Door Off Cabinet) by slacking the hinge arm mounting screw
 Ajuste de adelante hacia atrás (espaciado entre la puerta y el gabinete) aflojando el tornillo de montaje del brazo de la bisagra
 Ajustement d'avant en arrière (espacement de la porte hors de l'armoire) en desserrant la vis de montage du bras de charnière



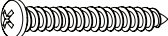

HARDWARE QUINCAILLERIE / HERRAJE



(A)	Minifix Bolt EU24  28 units	(B)	Minifix Cam 15/9.5  28 units	(C)	Dowel M8x30mm  28 + 2 units
(D)	Unita M6.3 x 40mm  20 units	(E)	Screw M3.5 x 15mm  8 units	(F)	Screw #10 x 1/2"  18 + 2 units
(G)	Nail Pin 3/4"  17 units	(H)	Shelf Support  8 units	(I)	Door Stopper  2 units
(J)	PVC L Bracket  2 units	(K)	Hinges Inside - 7/8"  4 units	(L)	F5211 Handle  2 units
(M)	Screw M4 x 19mm  2 units	(N)	Allen Key M4  1 unit	(O)	Nail Leg  2 units
(P)	Screw #8 x 38mm  4 units	(Q)	Mounting L Bracket  2 units	(R)	Washer M6 x 16mm  2 units
(S)	Seal Sticker  6 units				

- Hardware quantity may supplied more than it required. Please keep spares and tools for future use.
- La cantidad de hardware puede suministrarse más de lo requerido. Guarde los repuestos y las herramientas para uso futuro.
- La quantité de matériel peut fournir plus que nécessaire. Veuillez conserver les pièces de rechange et les outils pour une utilisation future.

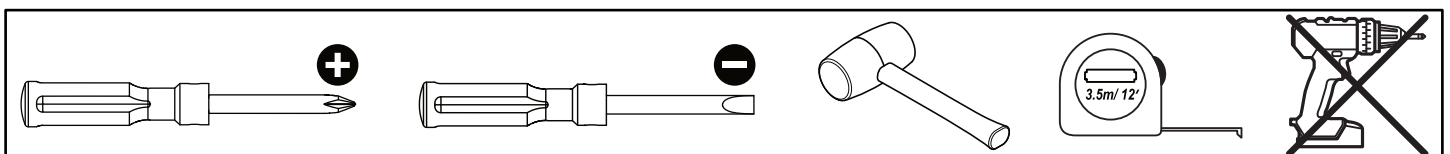
TOOLS NOT INCLUDED OUTILS PAS INCLUS / HERRAMIENTAS NO INCLUIDAS



STEP 1

		
E x 1	J x 1	C x 6

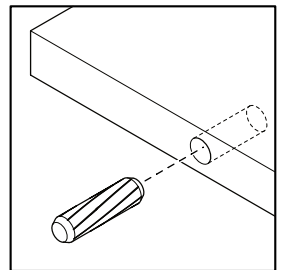
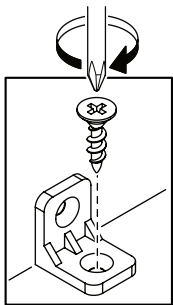
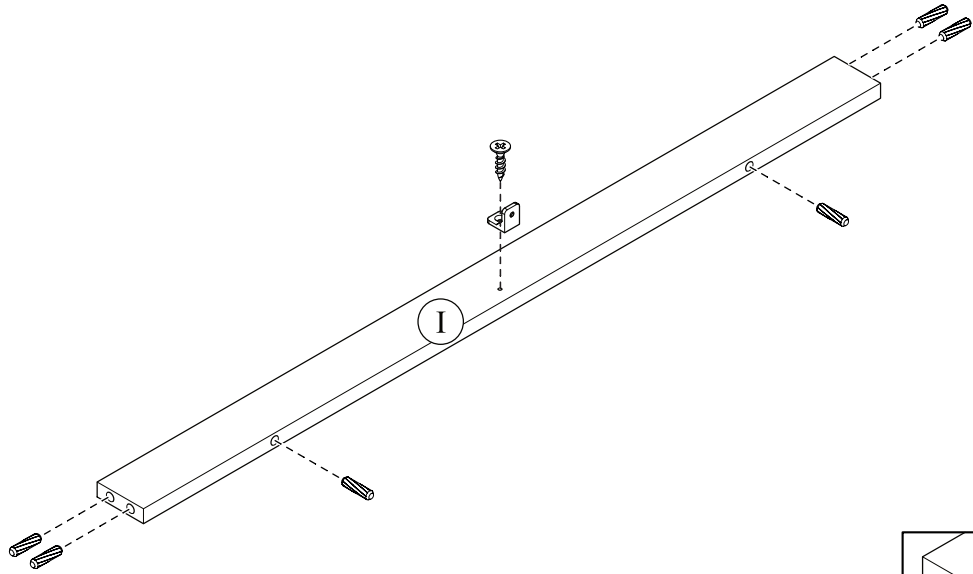

STEP 2

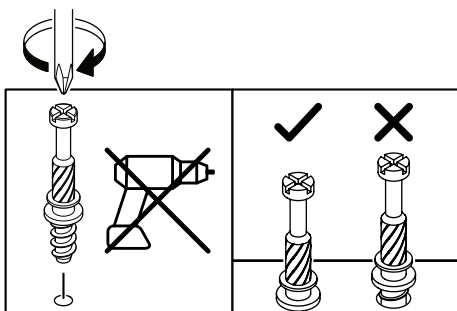
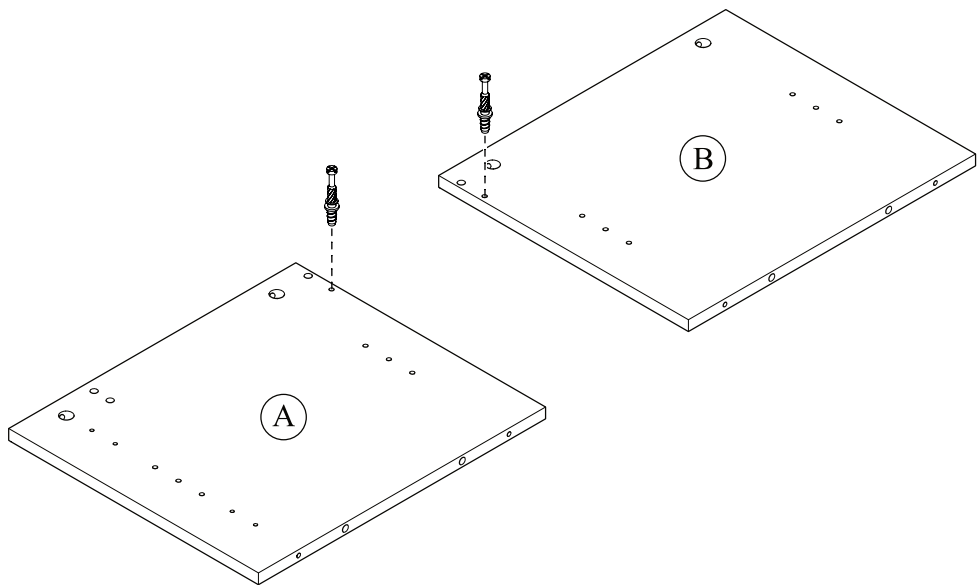

A x 2

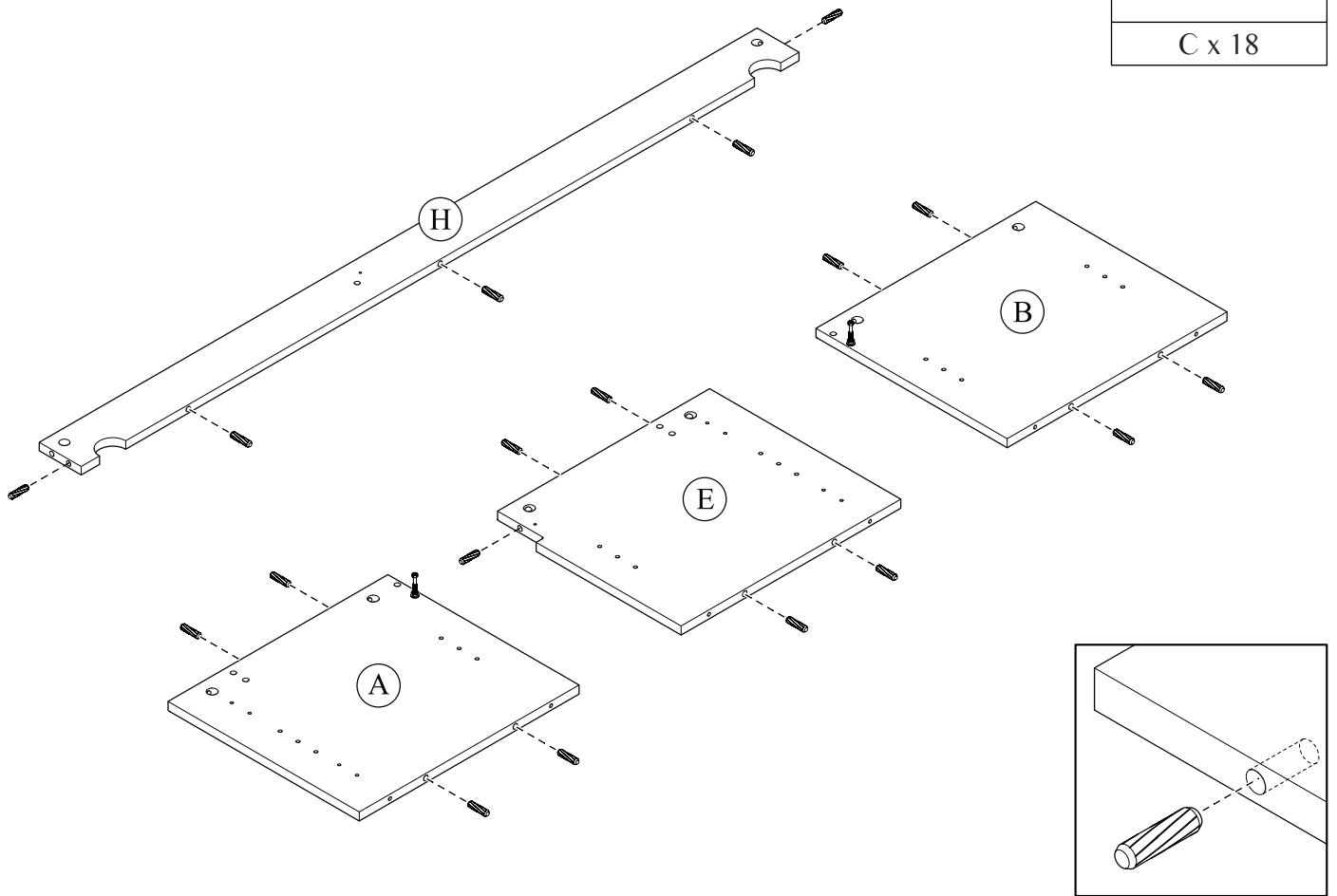

STEP 3

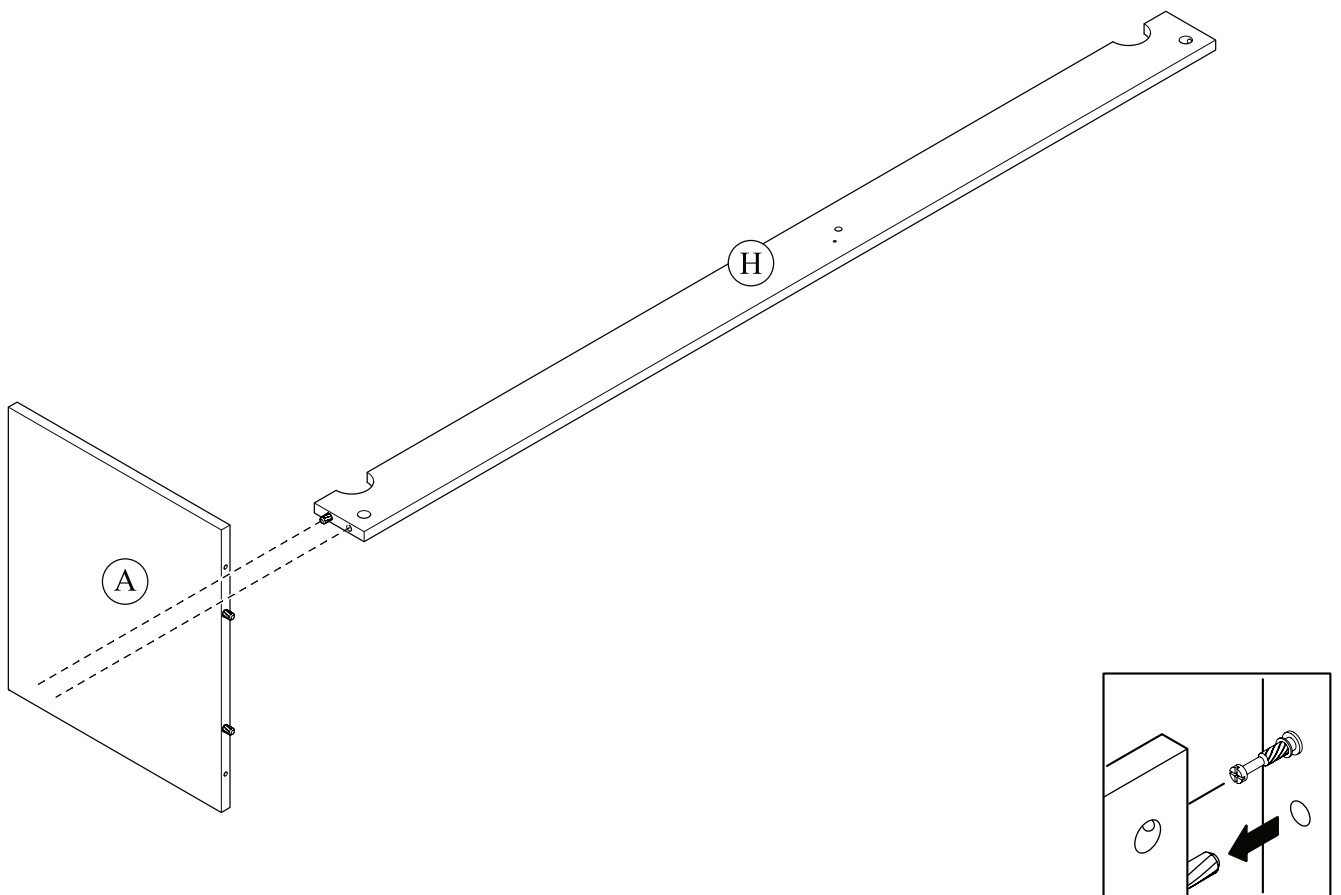

STEP 4



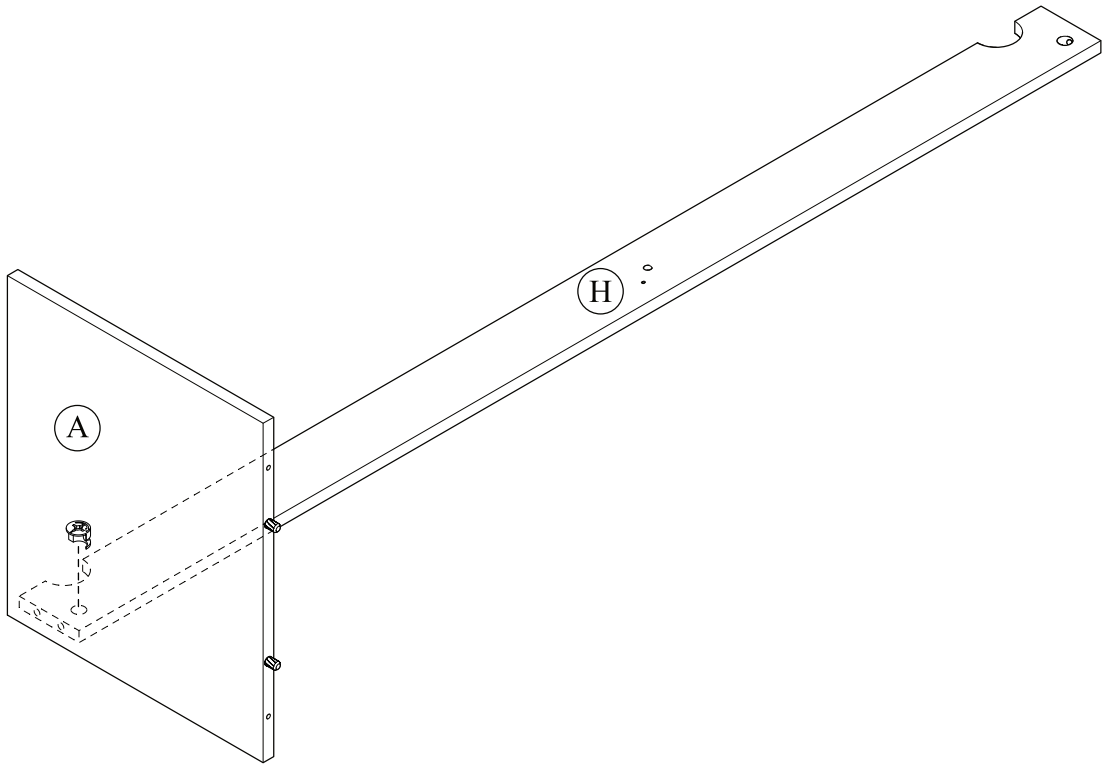
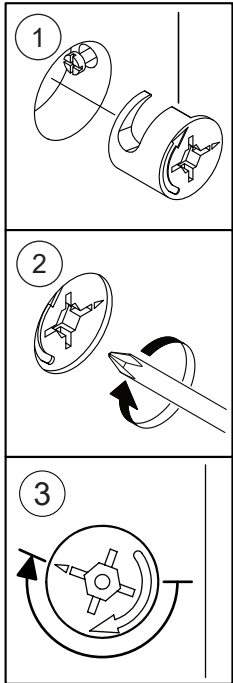

STEP 5

B x 1



STEP 6

	
E x 1	J x 1

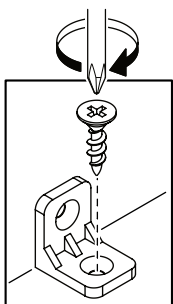
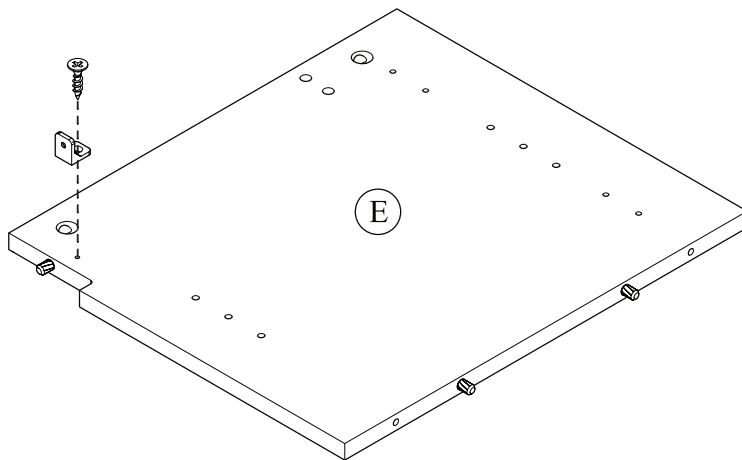

STEP 7

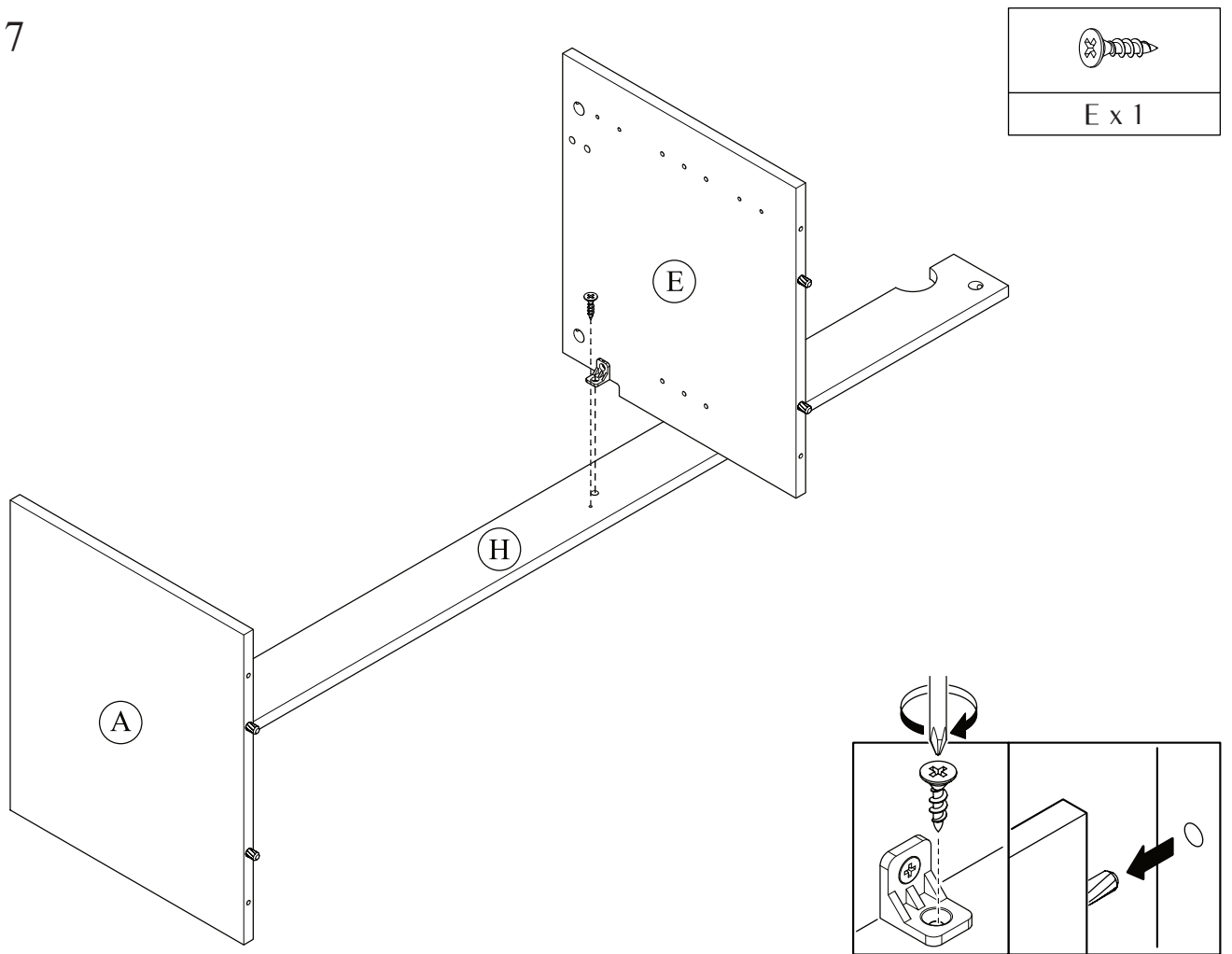

STEP 8

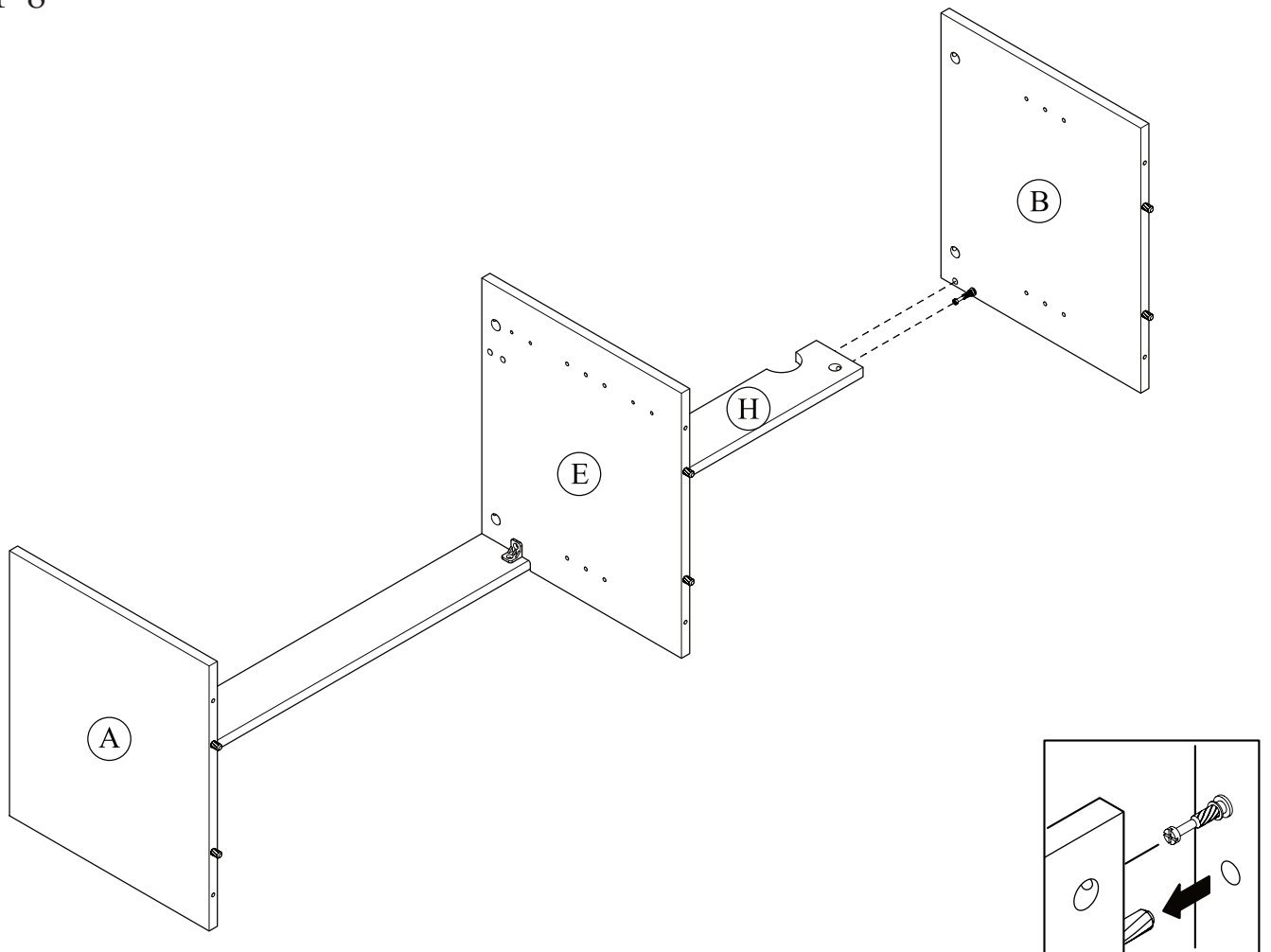

STEP 9

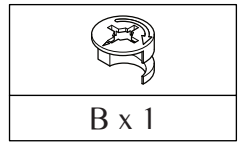
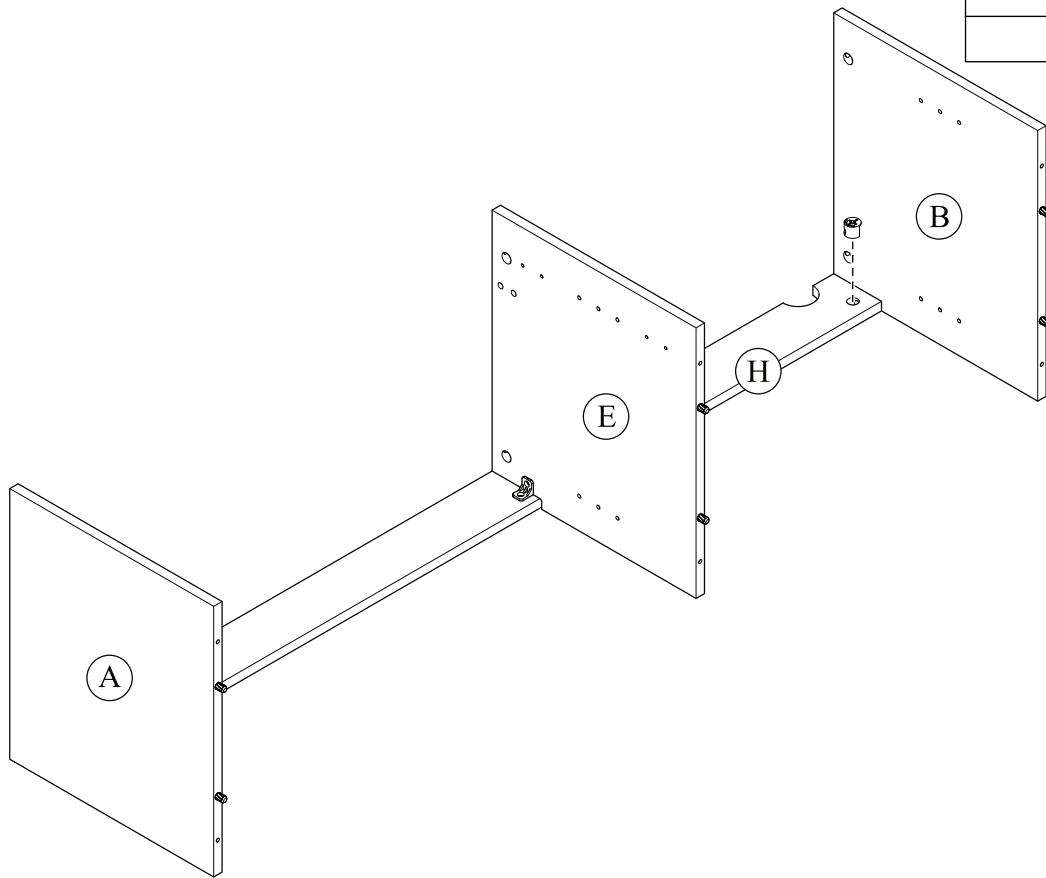
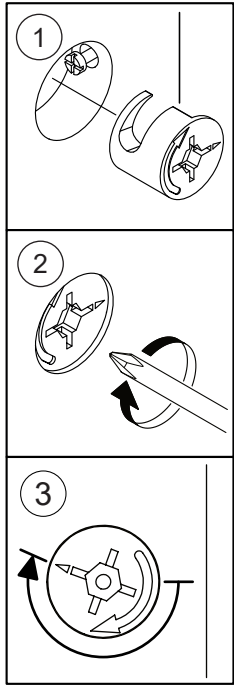

STEP 10

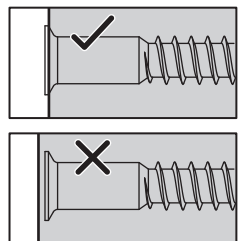
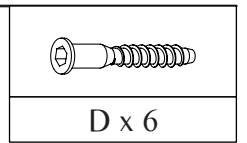
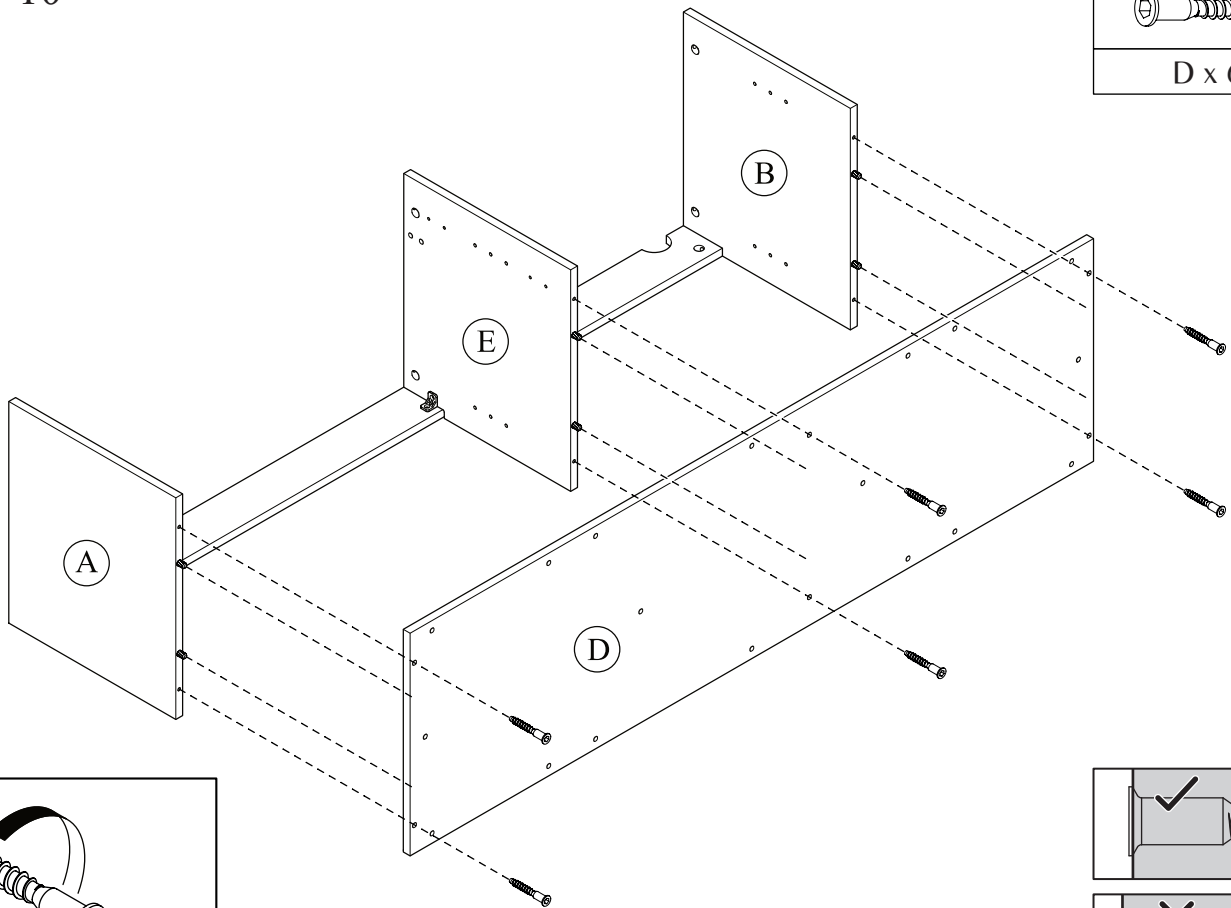
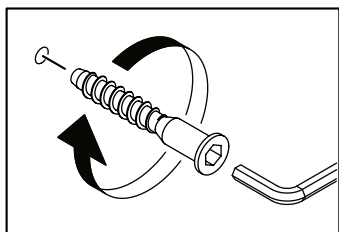

STEP 11

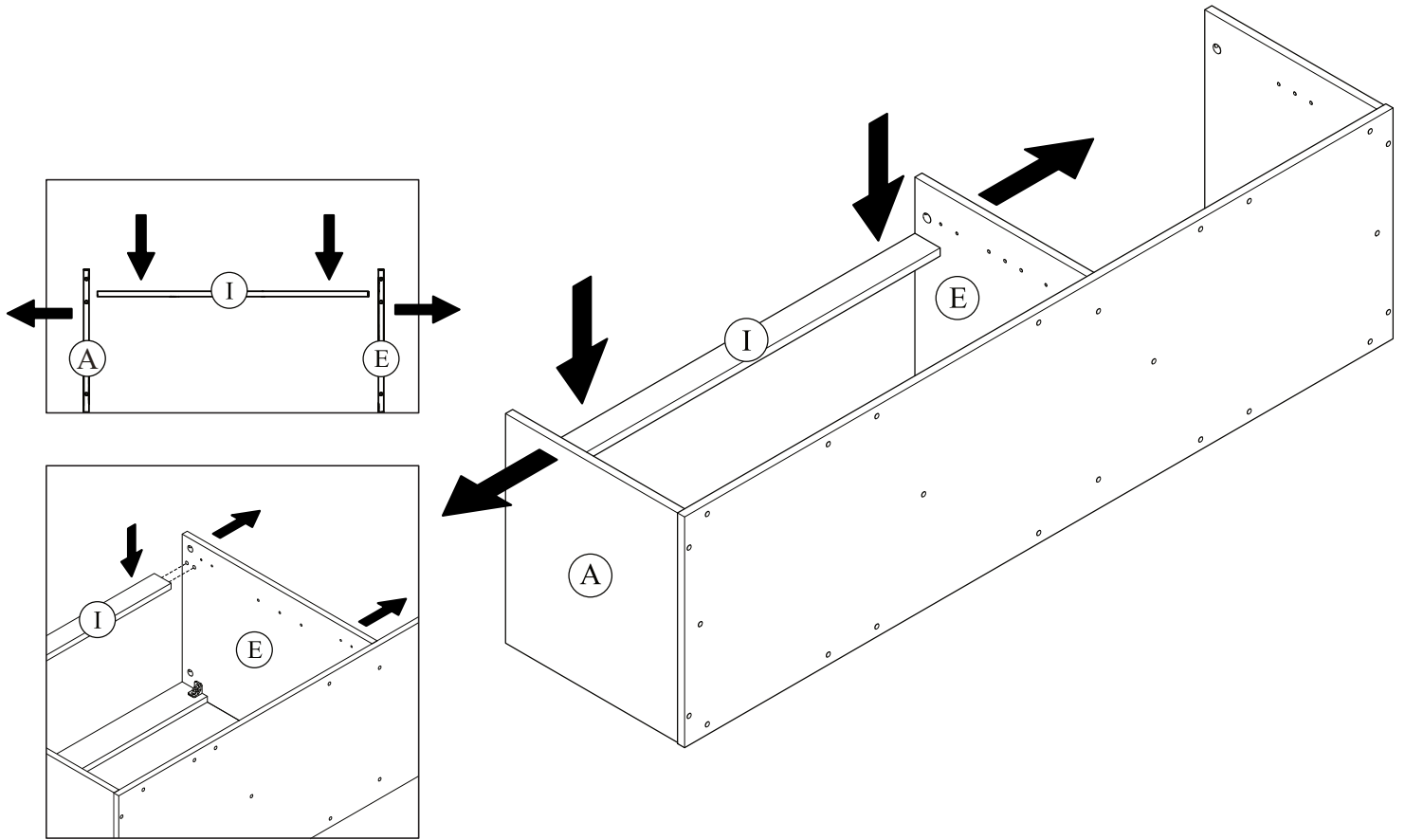

STEP 12

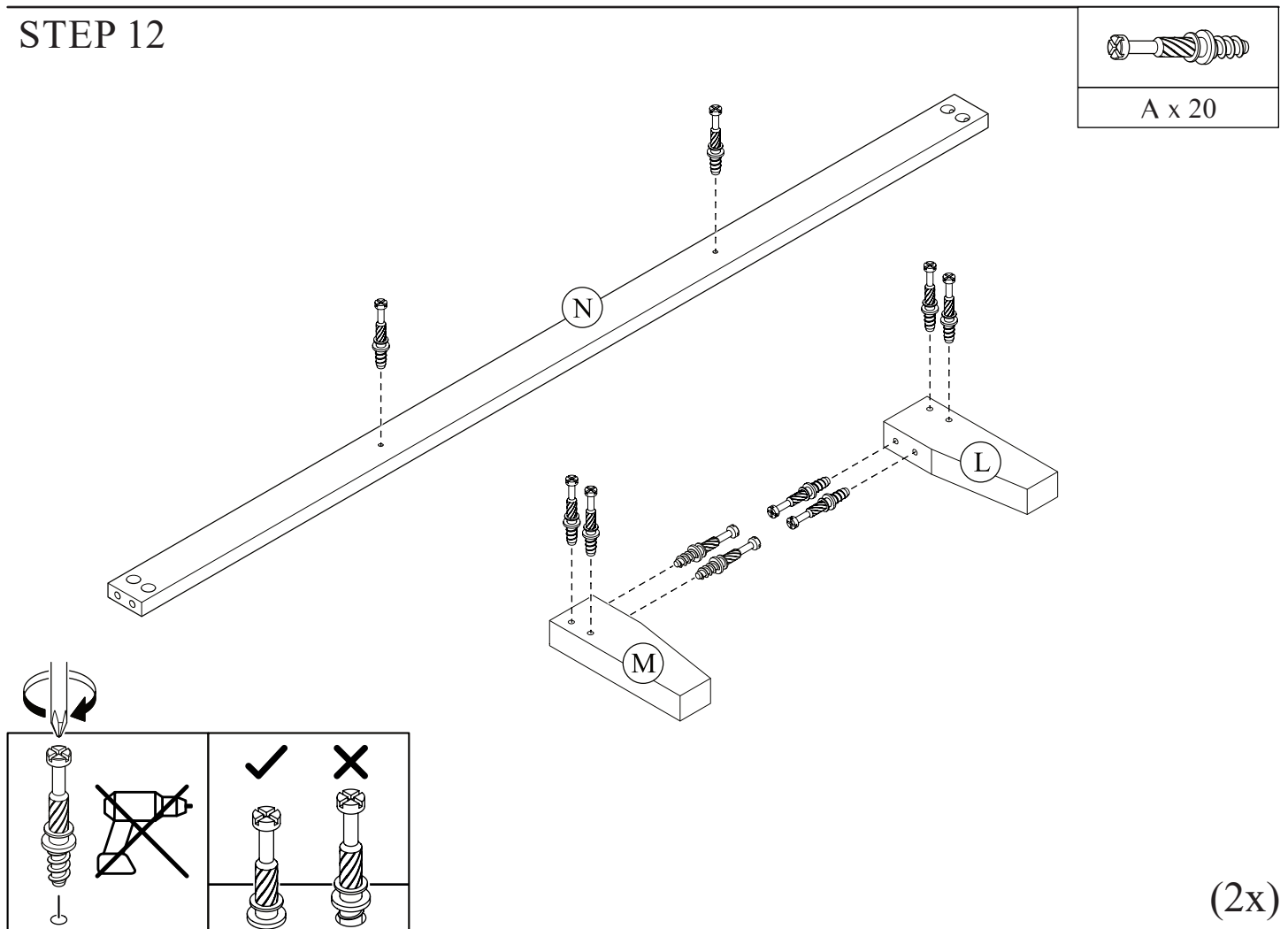

STEP 13

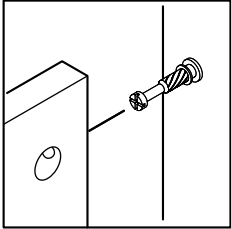
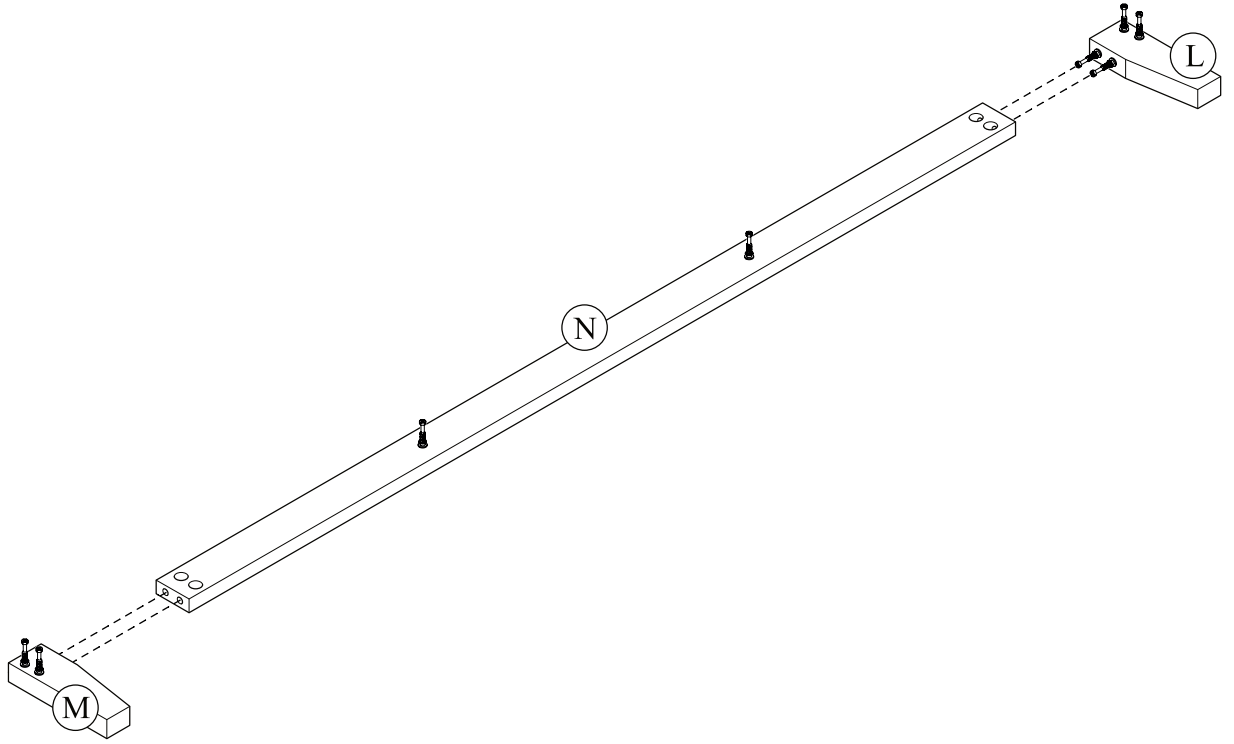

(2x)

STEP 14

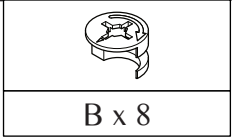

B x 8

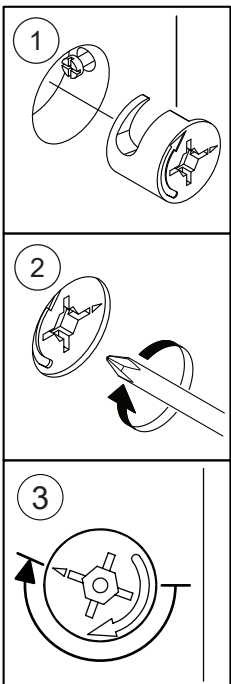
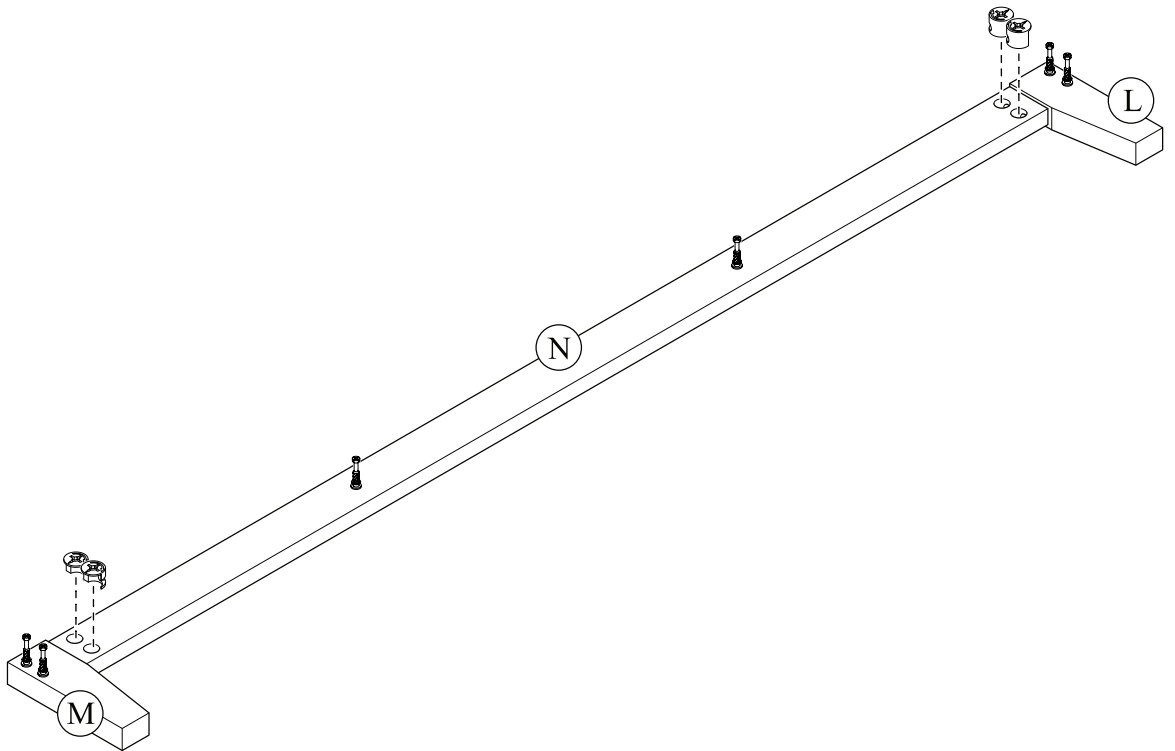

(2x)

STEP 15

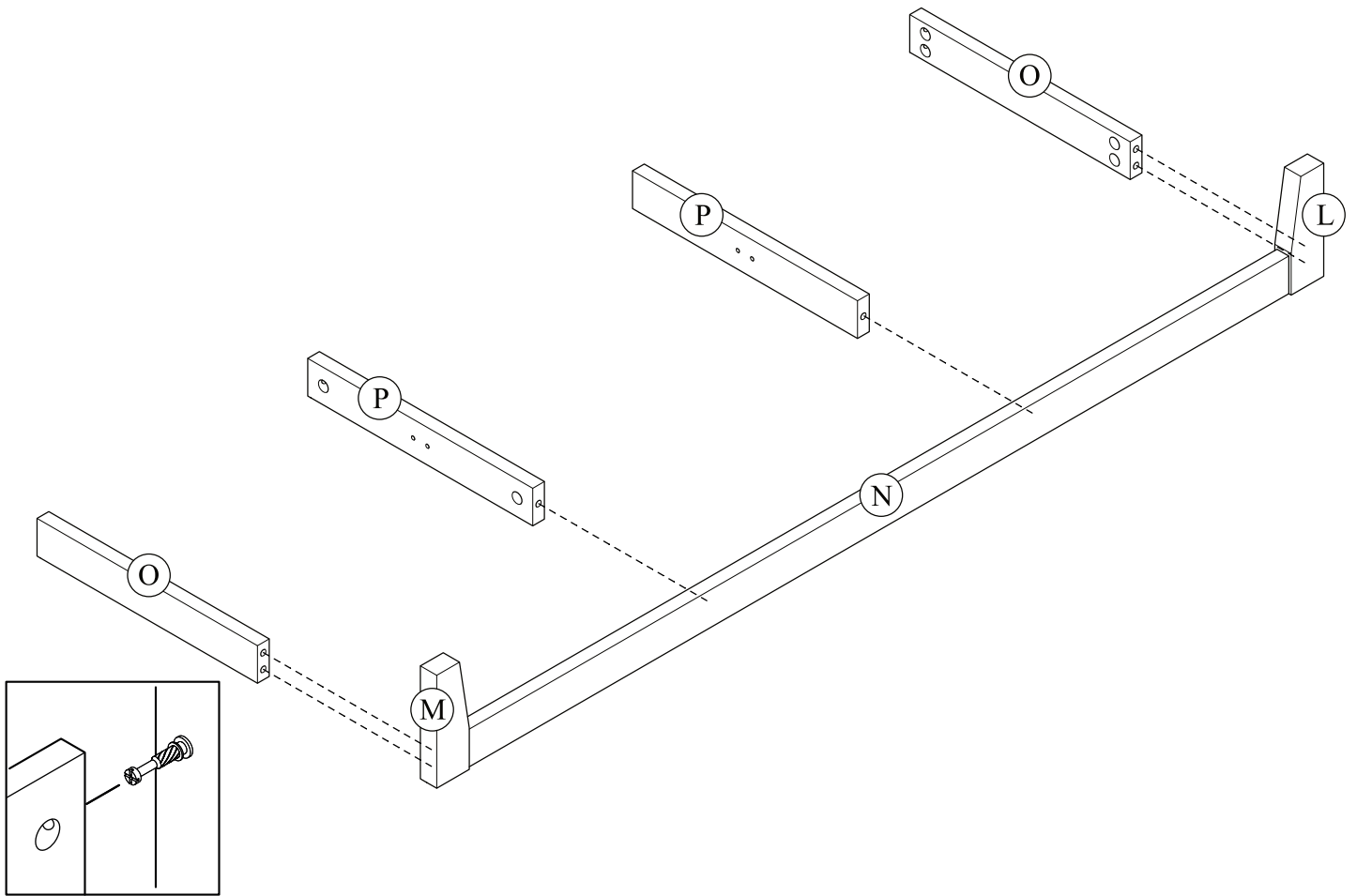

STEP 16

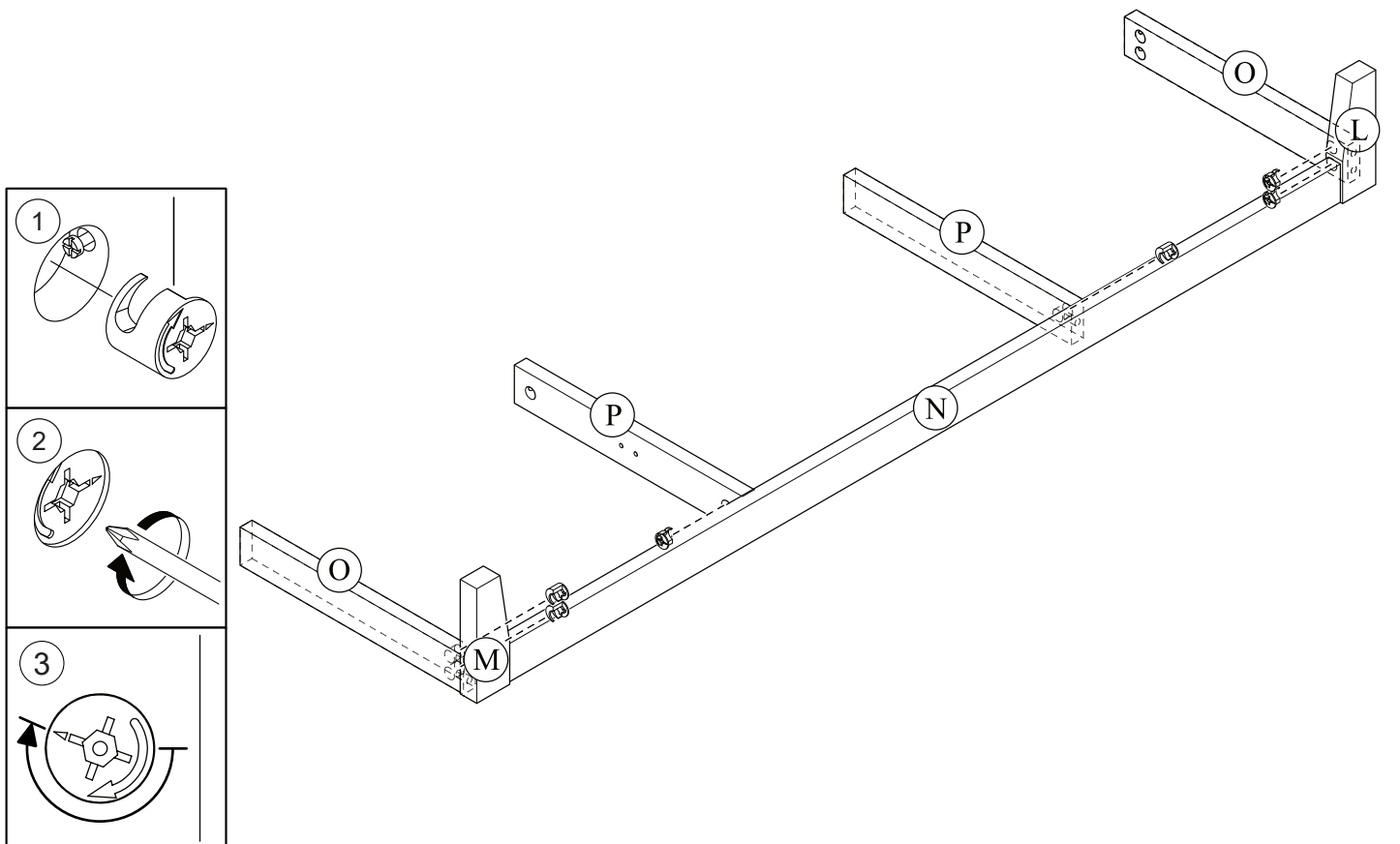
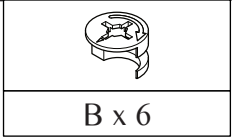

STEP 17

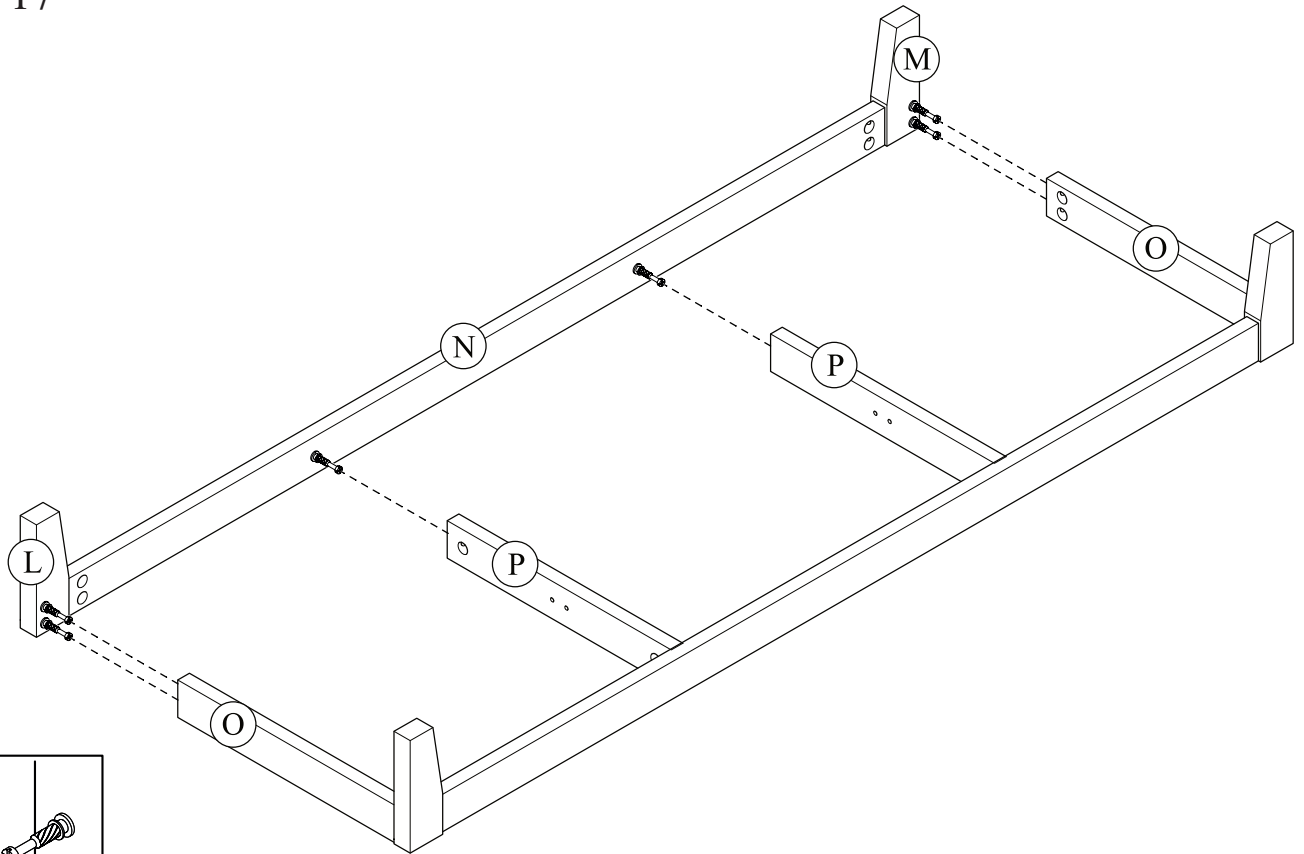

STEP 18



B x 6

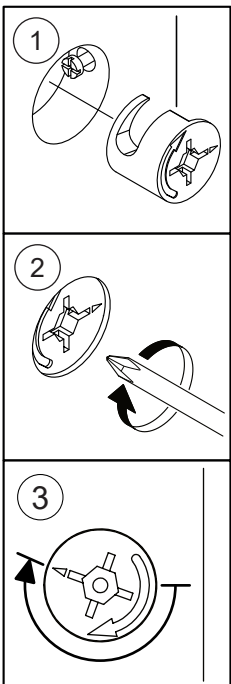
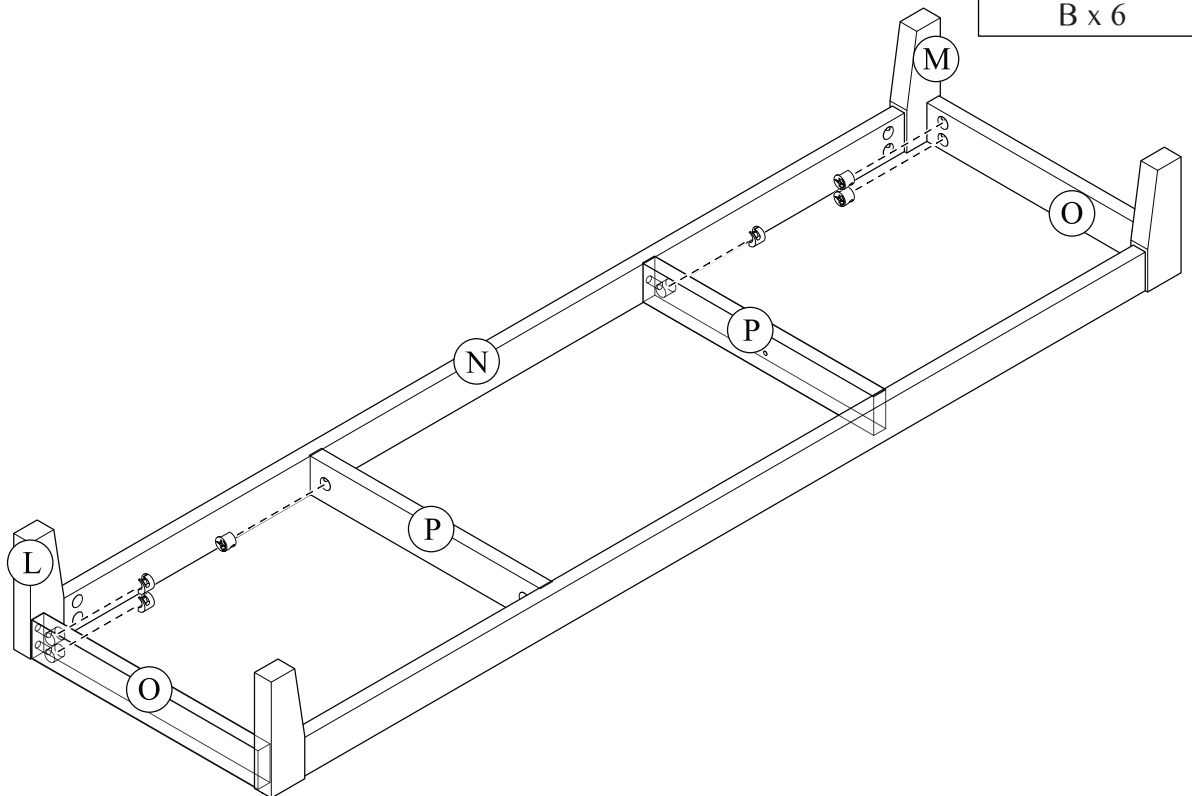

STEP 19

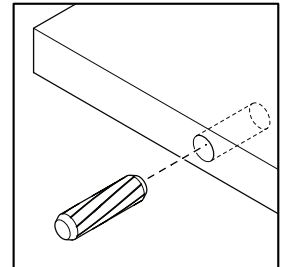
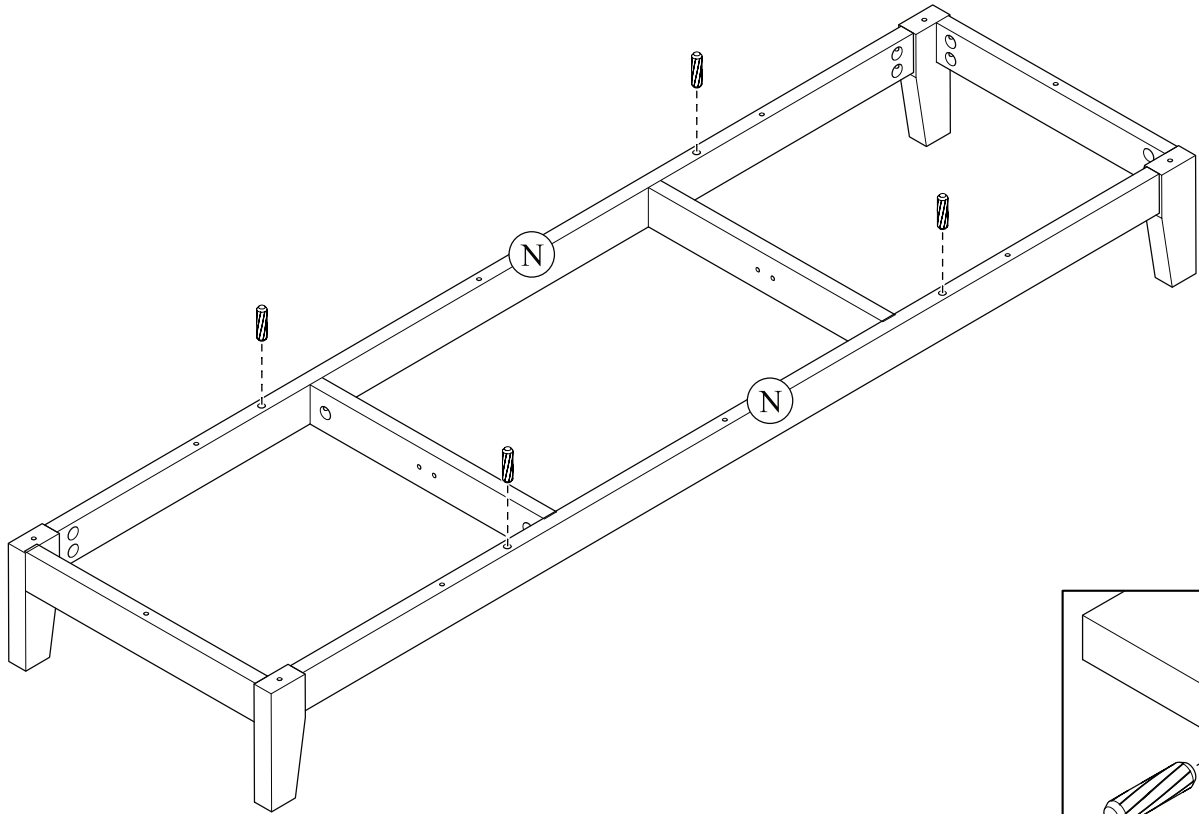
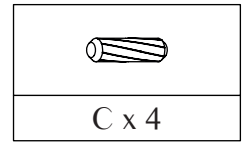

STEP 20

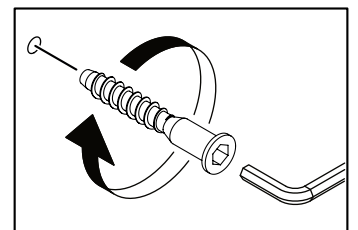
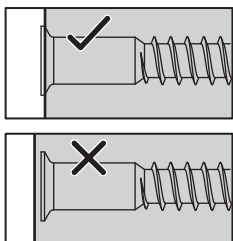
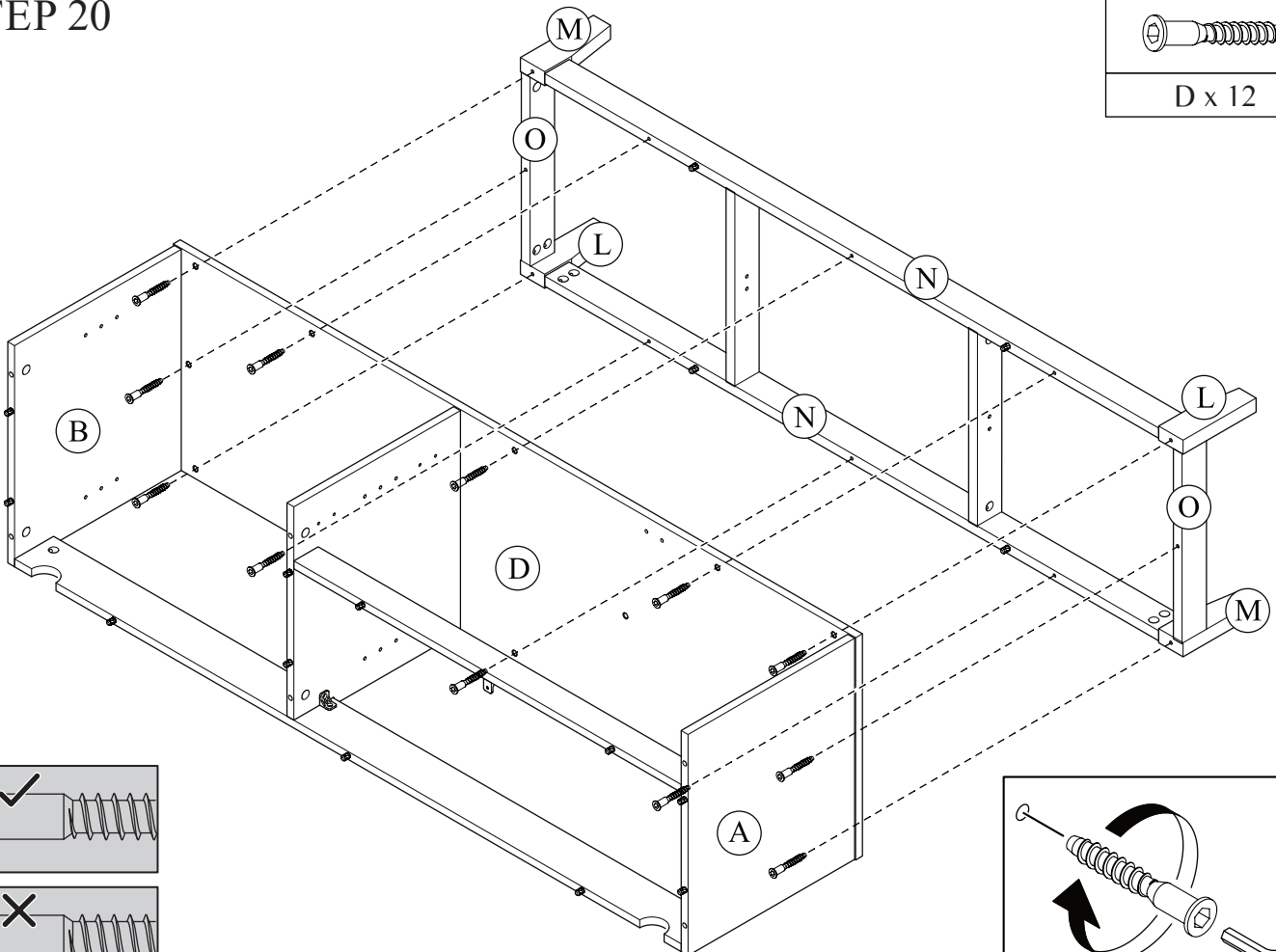
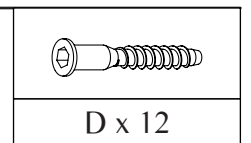

STEP 21

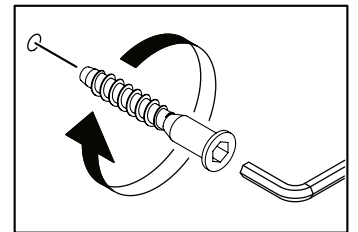
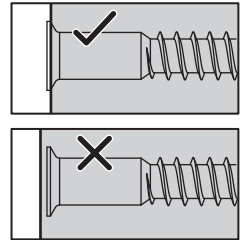
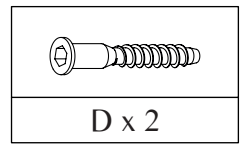
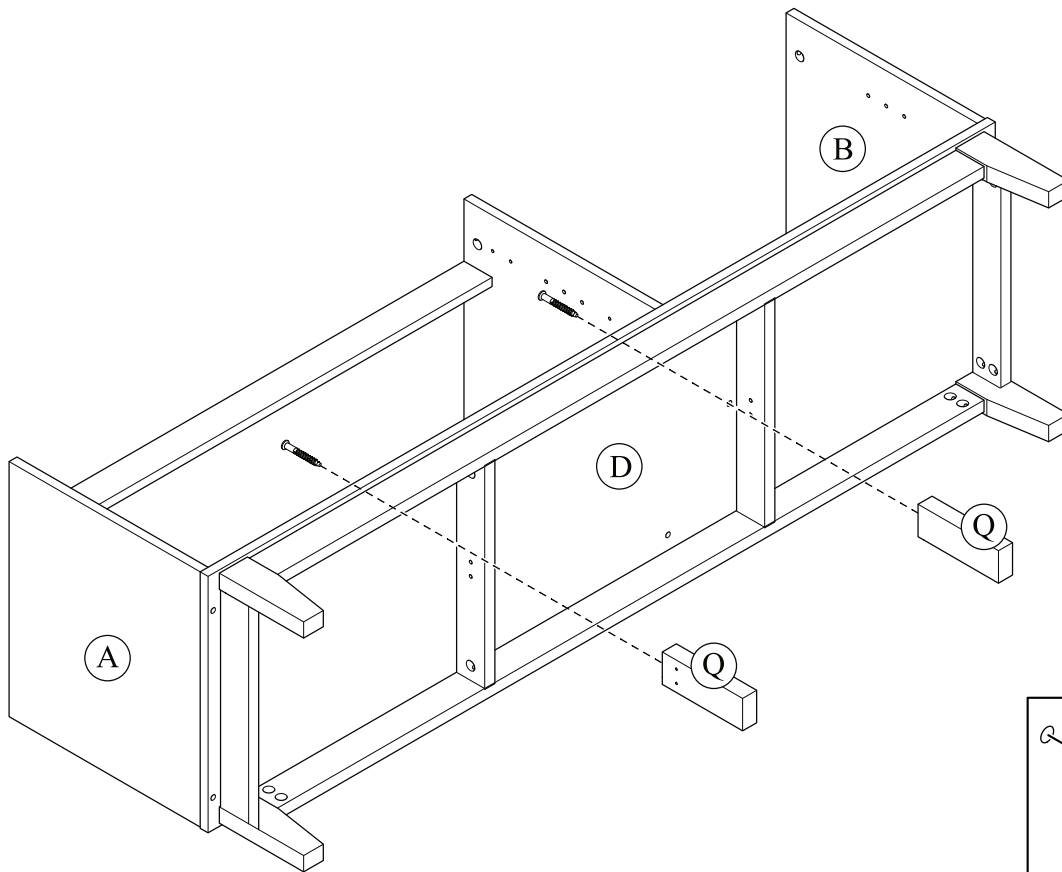

STEP 22

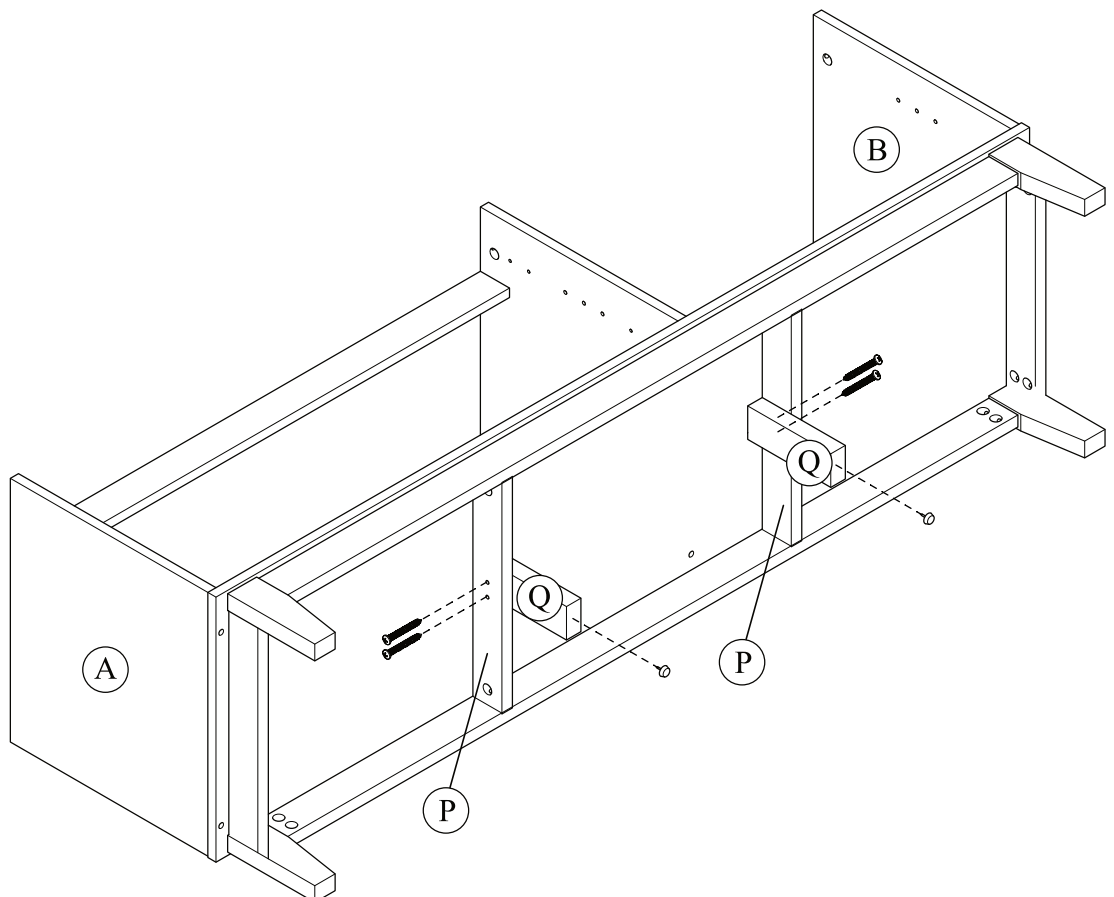
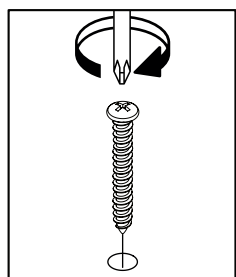
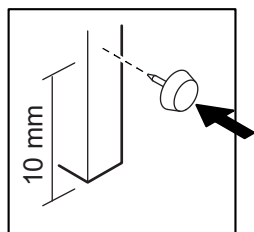
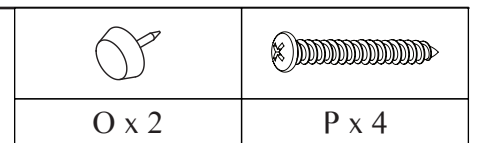

STEP 23

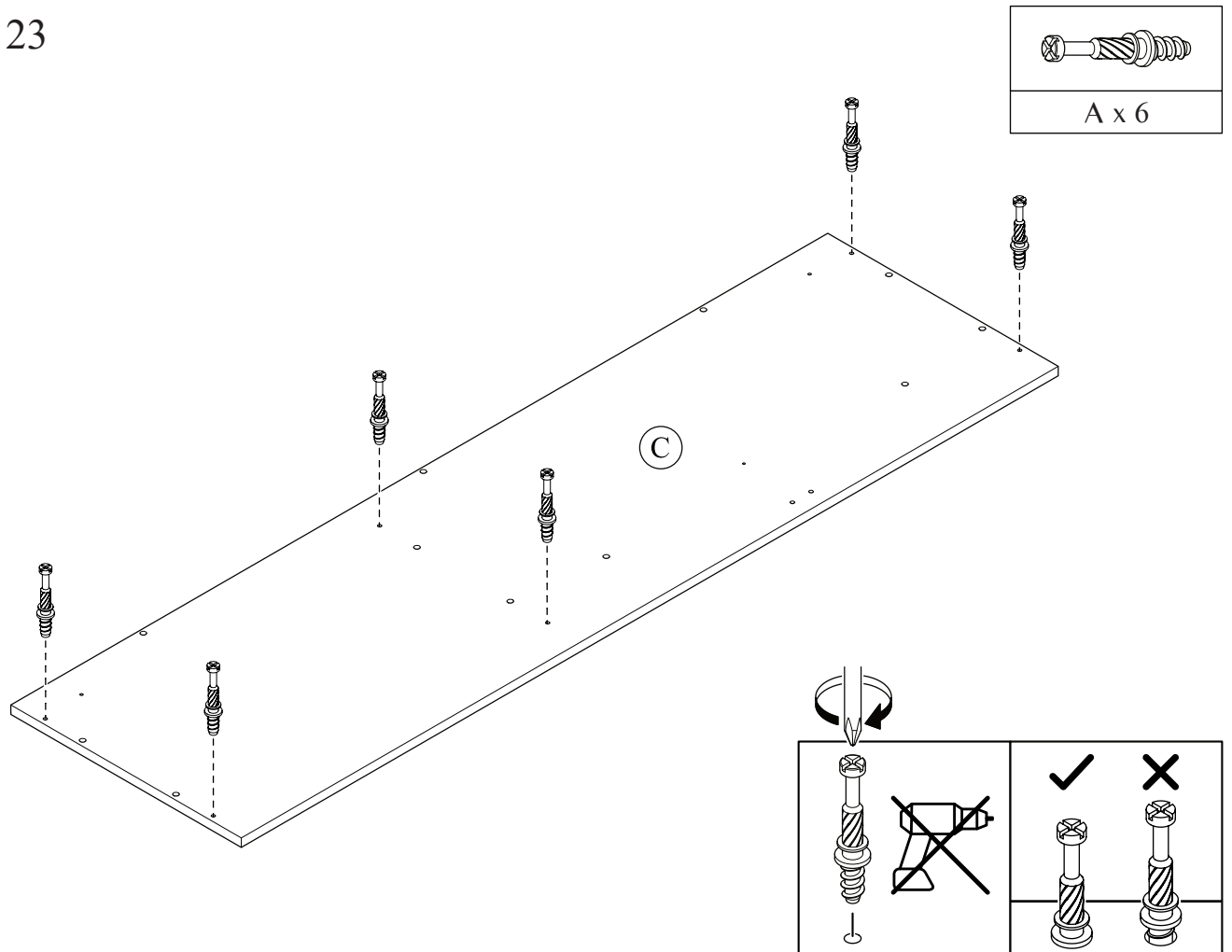

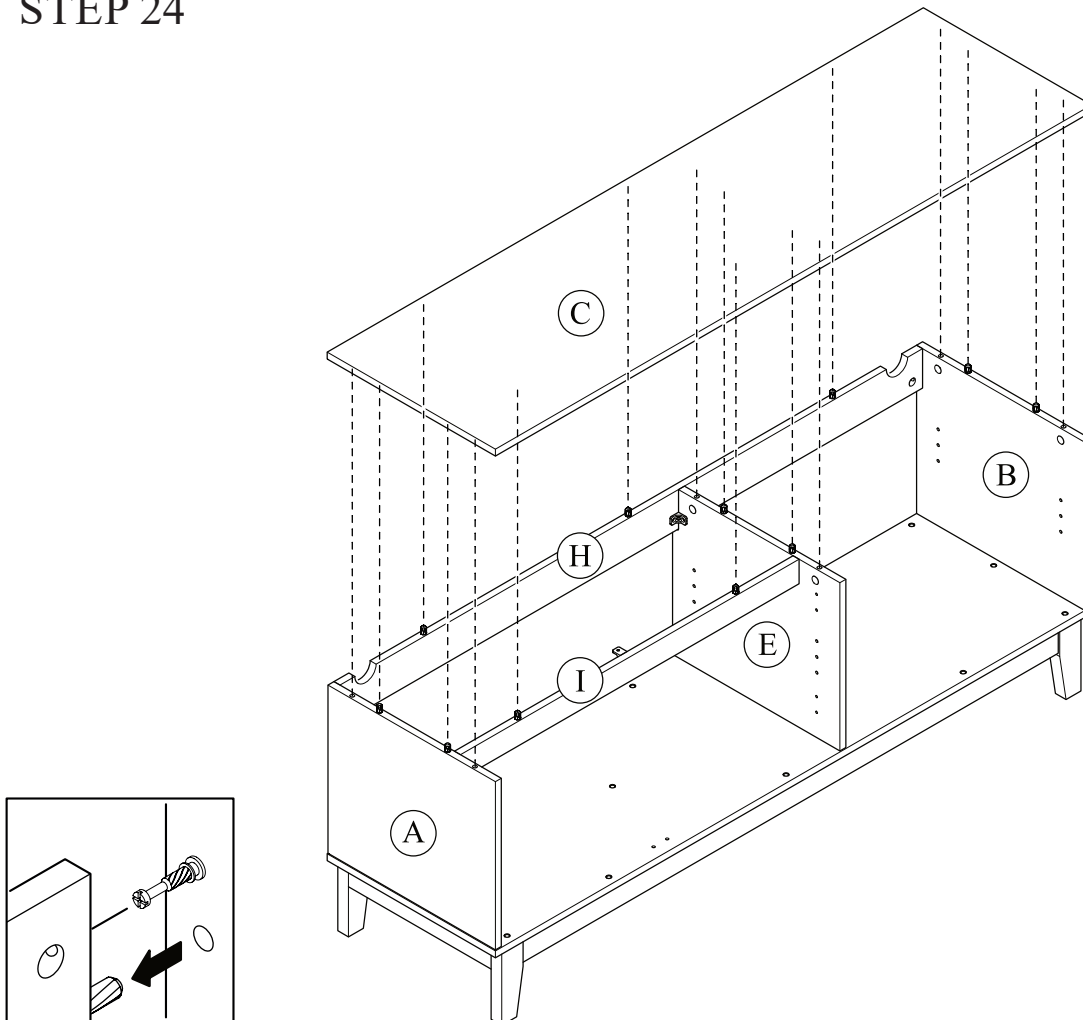

STEP 24

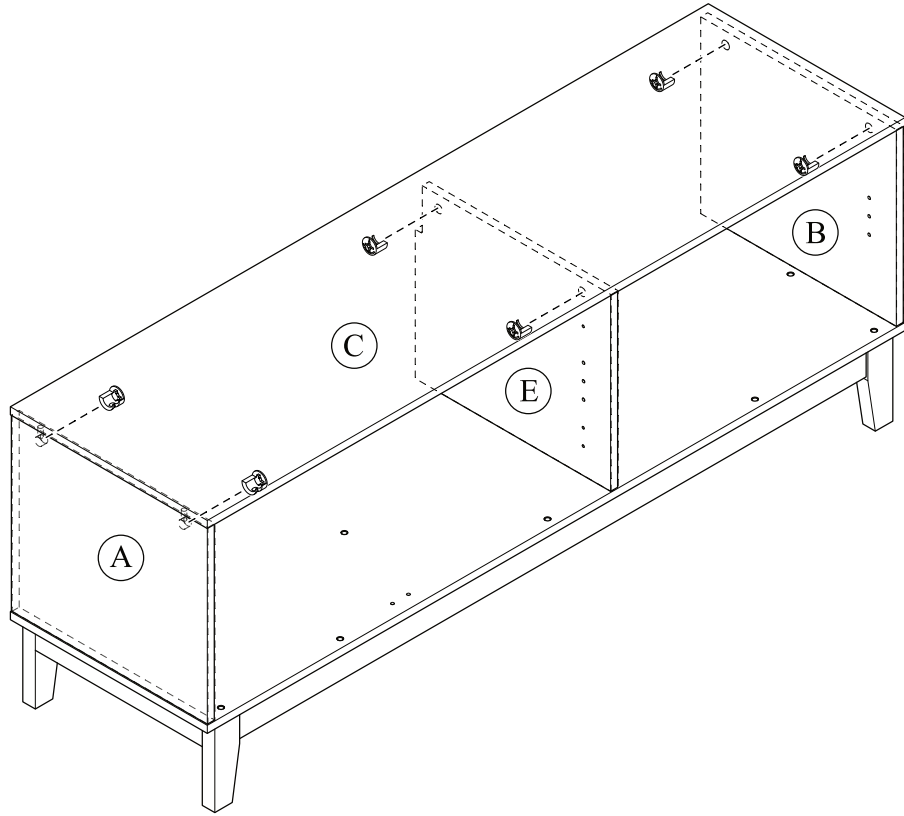
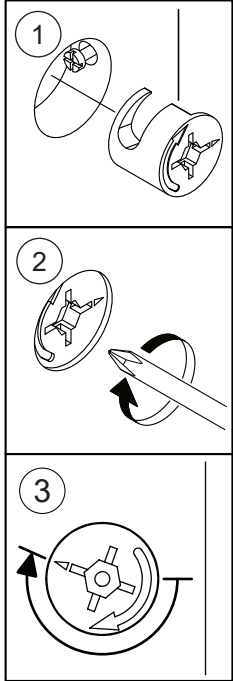
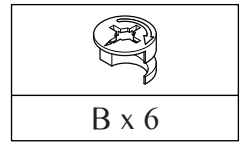

STEP 25

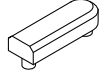

STEP 26

		
S x 6	I x 2	E x 1

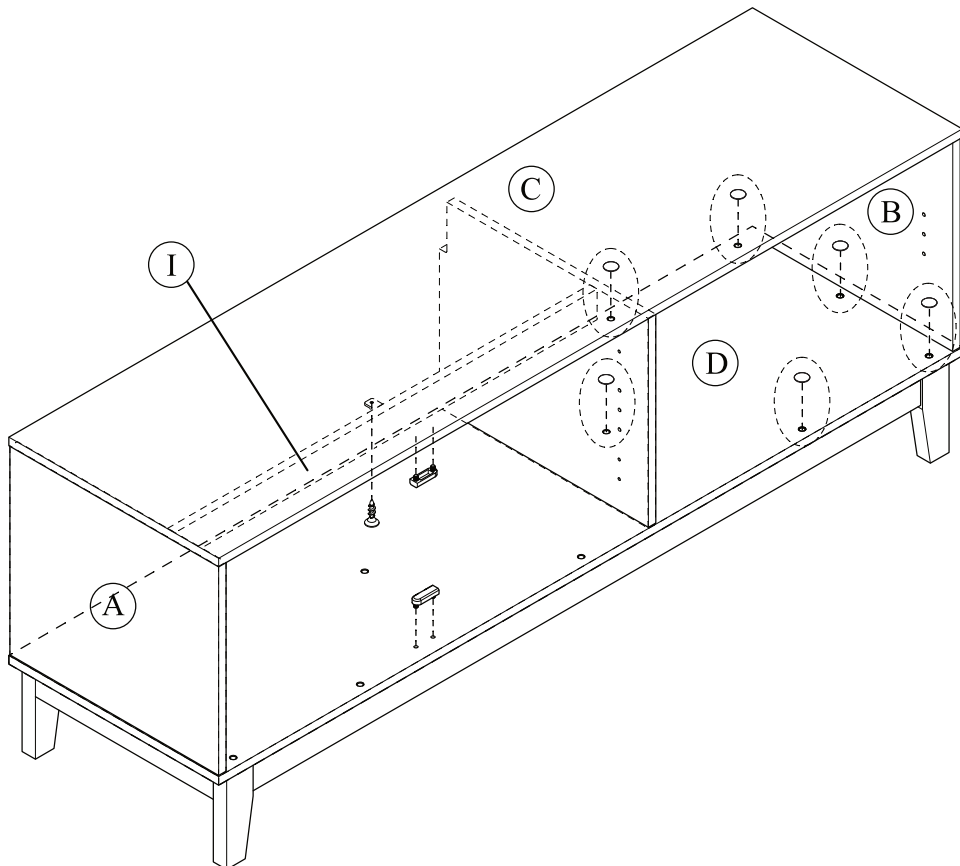
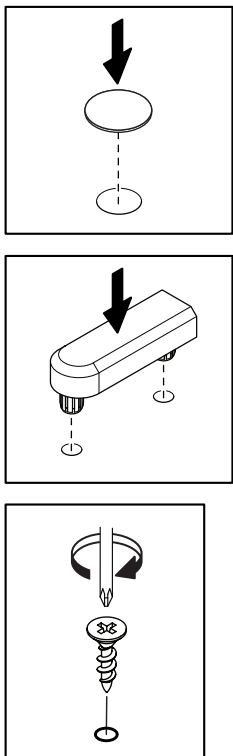

STEP 27

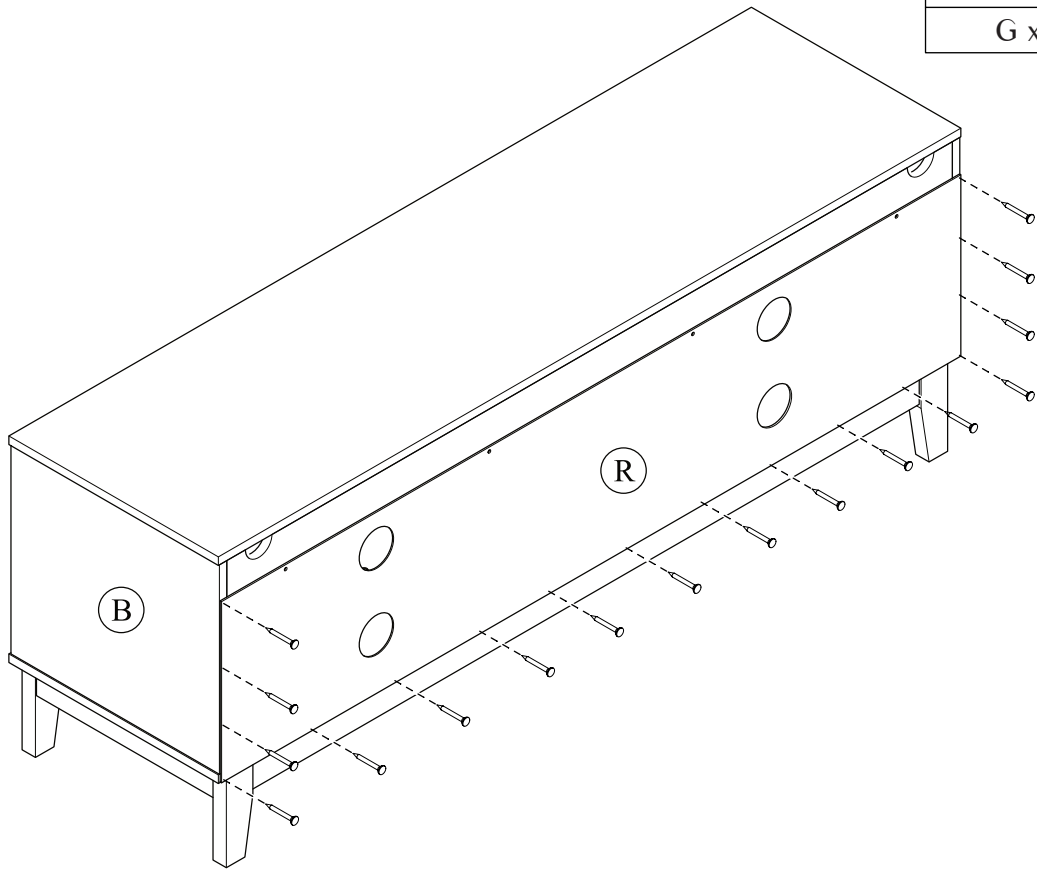
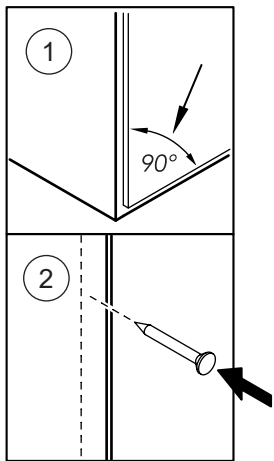
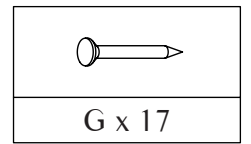

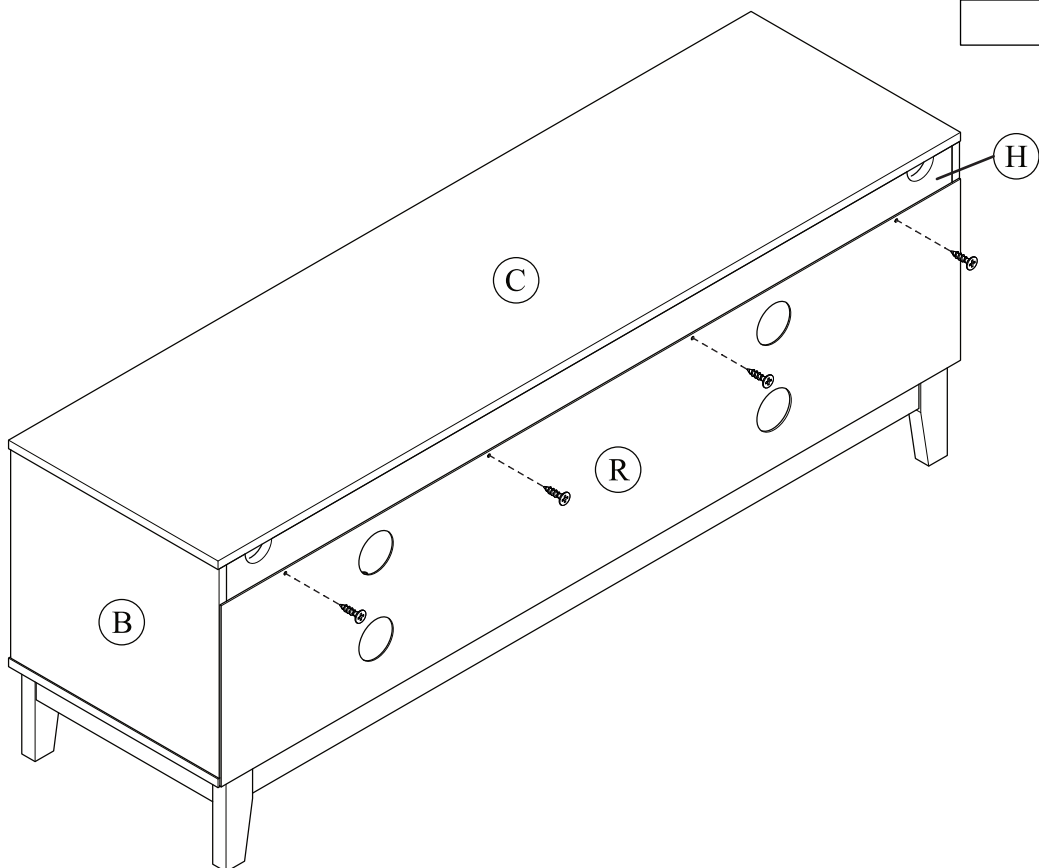
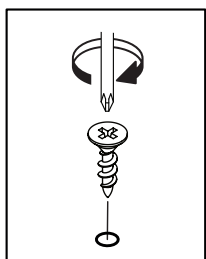
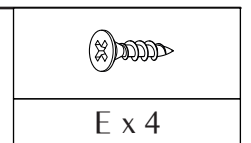

STEP 28

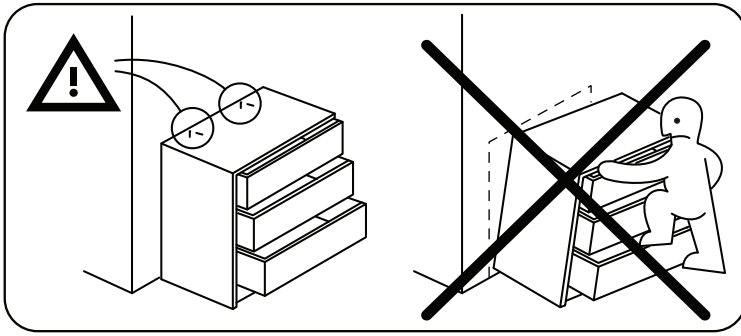

STEP 29



		
Q x 2	R x 2	F x 2

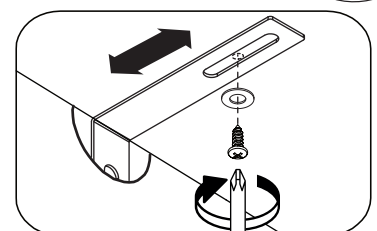
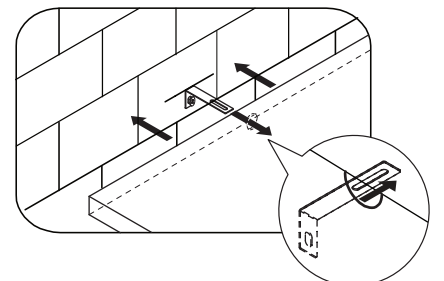
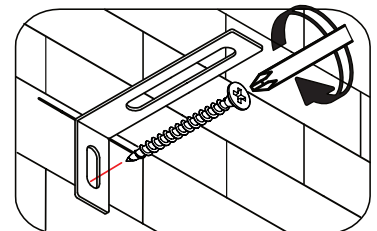
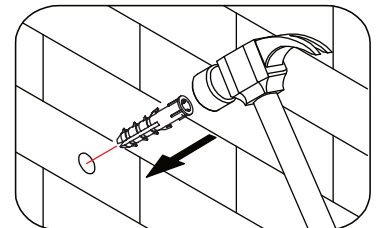
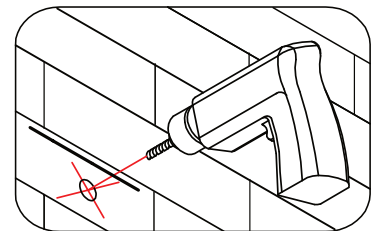
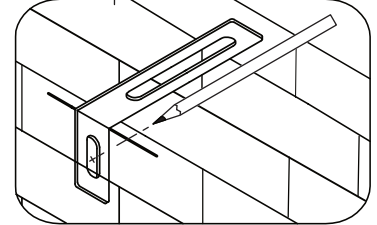
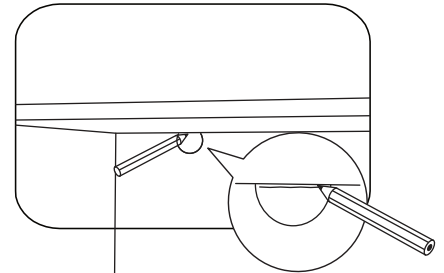
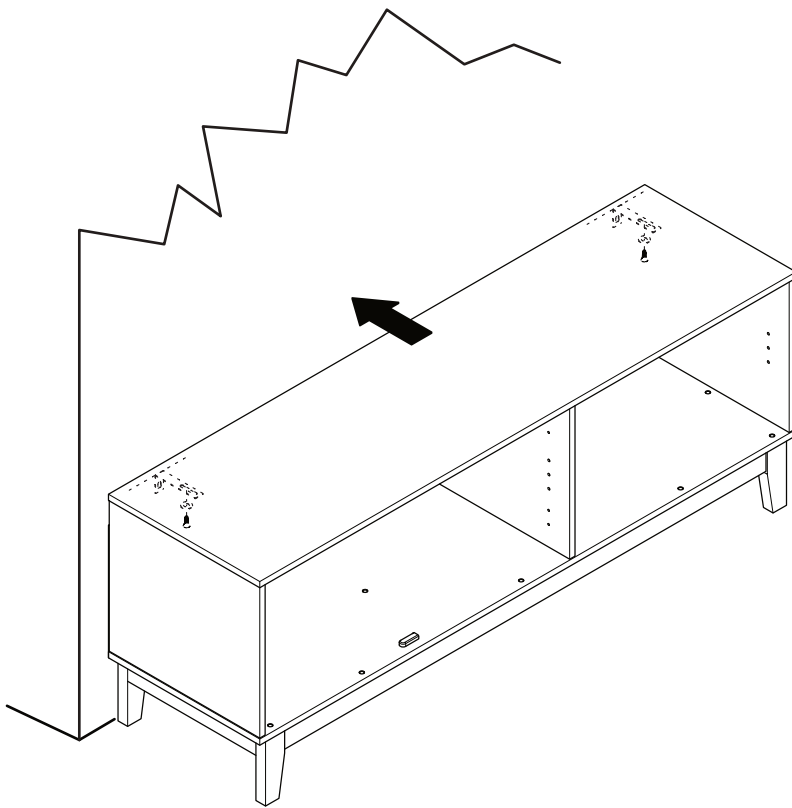

NOTE : Wall fixing are not supplied with this product as different wall materials require different types of fixing devices (such as Rawl plugs on brick work). You must use fixing devices suitable for the type of wall you intend to mount this product to. Please ensure that the head of any screw used has a diameter greater than the diameter of the mounting hole on the product and that the fixing is safe and secure before use.

The screws and washers which fix the brackets to furniture panels are included in your pack.

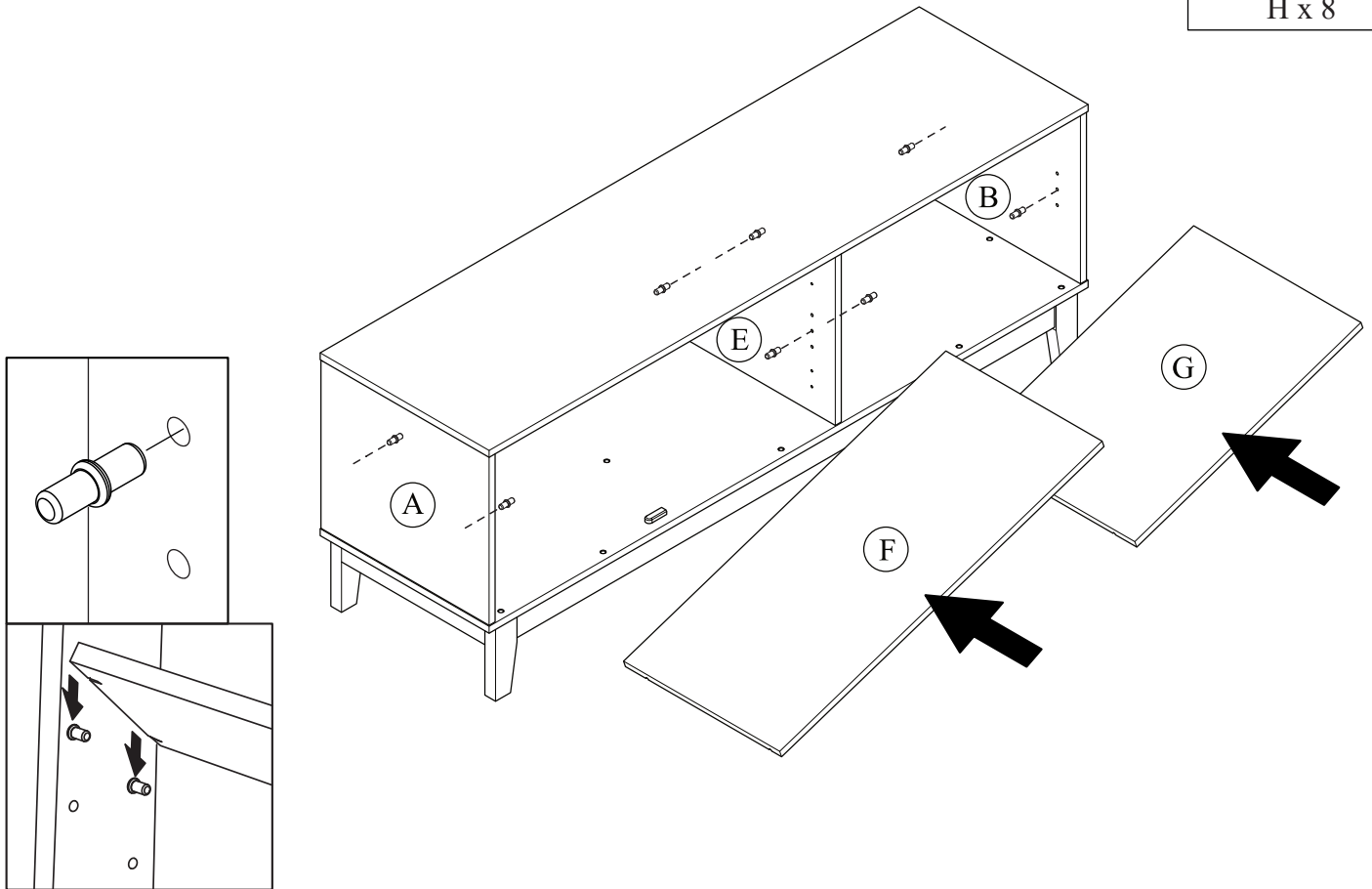
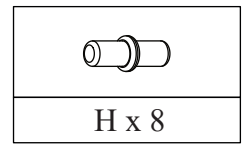

STEP 30

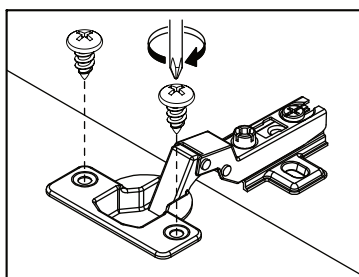
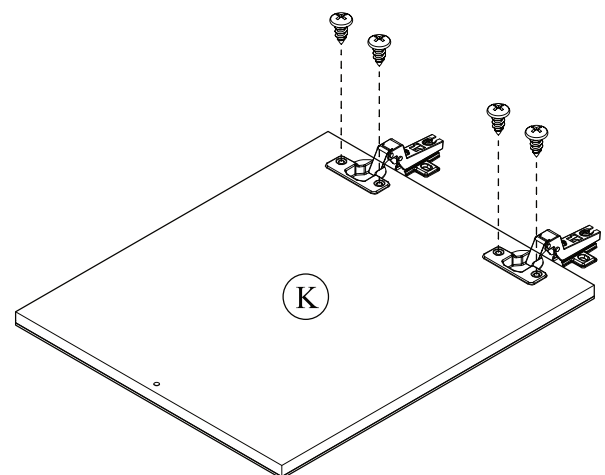
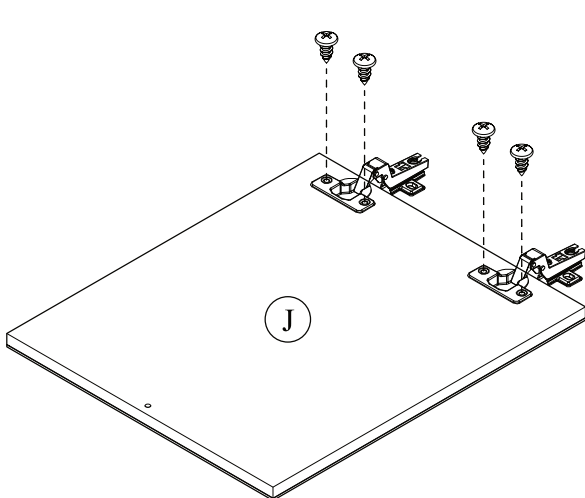
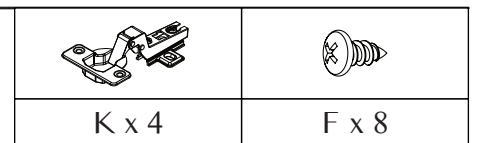

STEP 31

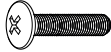

STEP 32

	
M x 2	F x 8
	
	L x 2

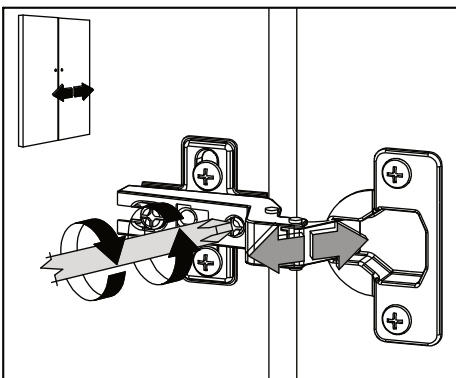
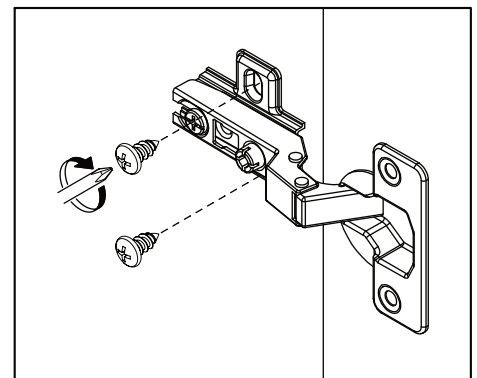
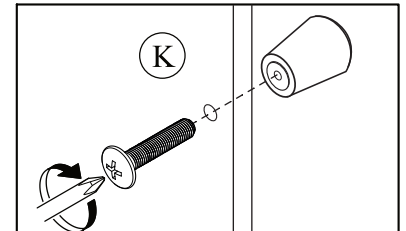
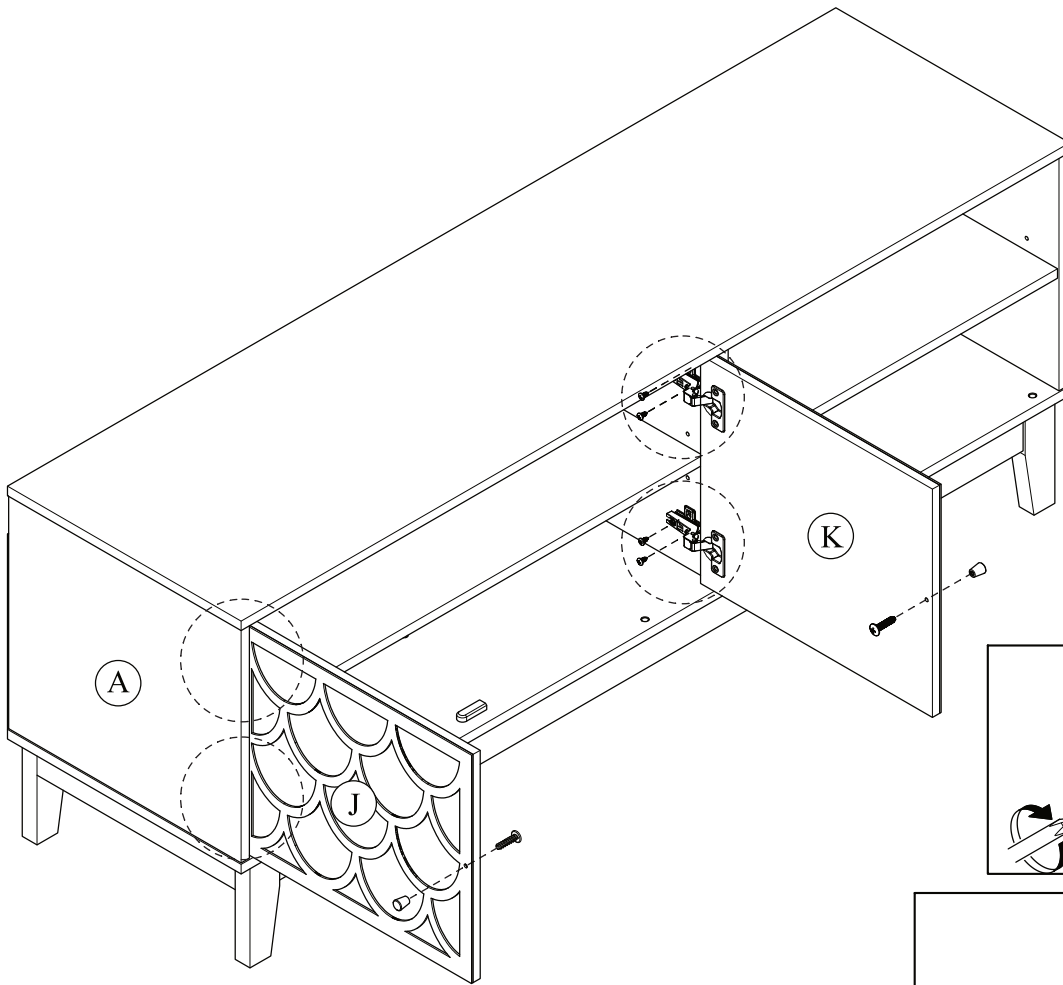

A. Lateral adjustment (Moving Door Left-Right) by screw adjusting

A. Ajuste lateral (puerta móvil izquierda-derecha) ajustando el tornillo

A. Réglage latéral (porte mobile gauche-droite) par réglage de la vis

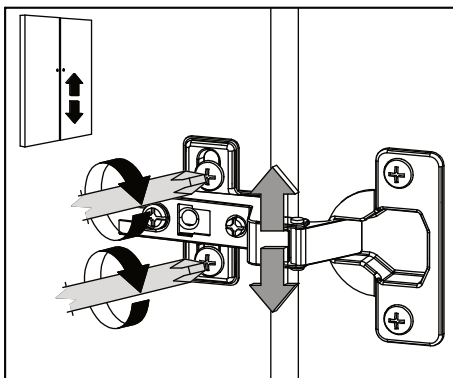

B. Vertical adjustment (Moving Door Up-Down) via slot in the mounting plate

B. Ajuste vertical (Moving Door Up-Down) a través de ranura en la placa de montaje

B. Réglage vertical (Moving Door Up-Down) via fente dans la plaque de montage

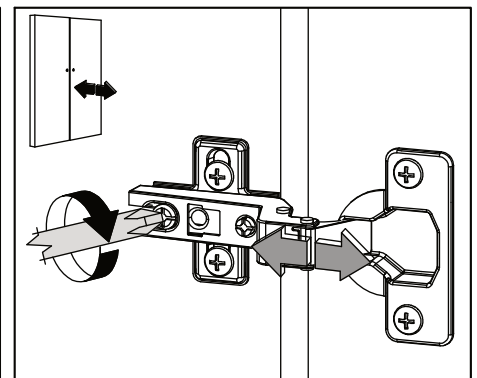

C. Front-to-back adjustment (Spacing Door Off Carcas) by slacking the hinge arm mounting screw

C. Ajuste de frente a espalda (puerta de espaciado de las canales) aflojando el tornillo de montaje del brazo de la bisagra

C. Réglage avant-arrière (Espacement de la porte hors carcasse) en relâchement de la vis de montage du bras de charnière

MAXIMUM LOADS CHARGES MAXIMALES / CARGA MAXIMA

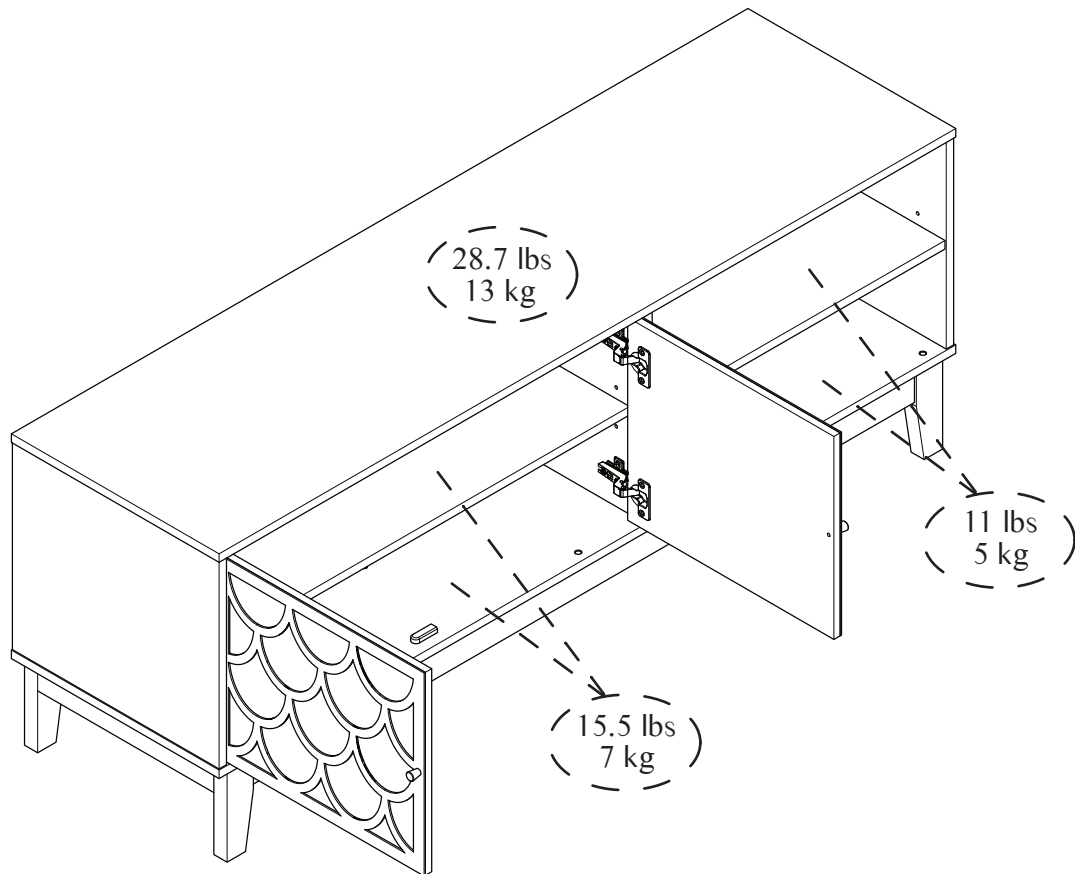

This unit has been designed to support the maximum loads shown. Exceeding these load limits could cause sagging, instability, product collapse, and/or serious injury.

Ce meuble a été conçu pour supporter les charges maximales indiquées. En excédant ces limites de charge, le meuble pourrait devenir instable, s'effondrer, et/ou causer des blessures graves.

Esta unidad ha sido diseñada para soportar la carga máxima anotada. El exceder estos límites puede causar inestabilidad, colapsarse y/o causar serias lesiones.
