

# Donna 3 DOOR WARDROBE WITH MIRROR

---

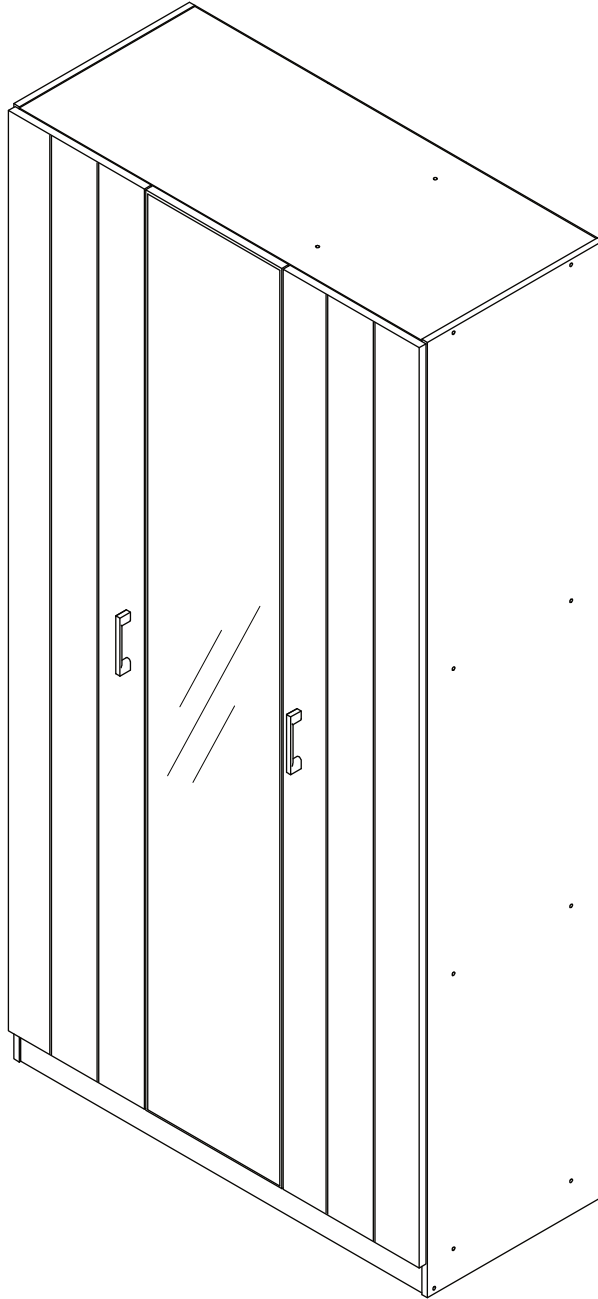

Tools Required  
*Alat yang diperlukan*

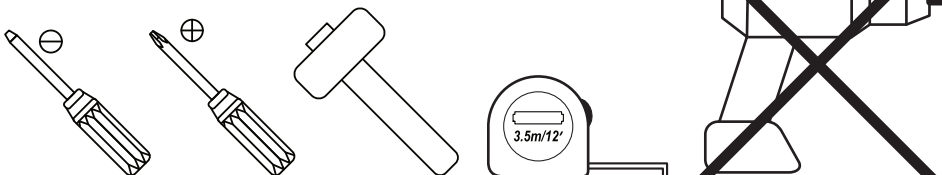



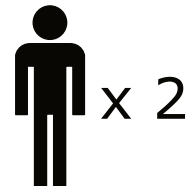



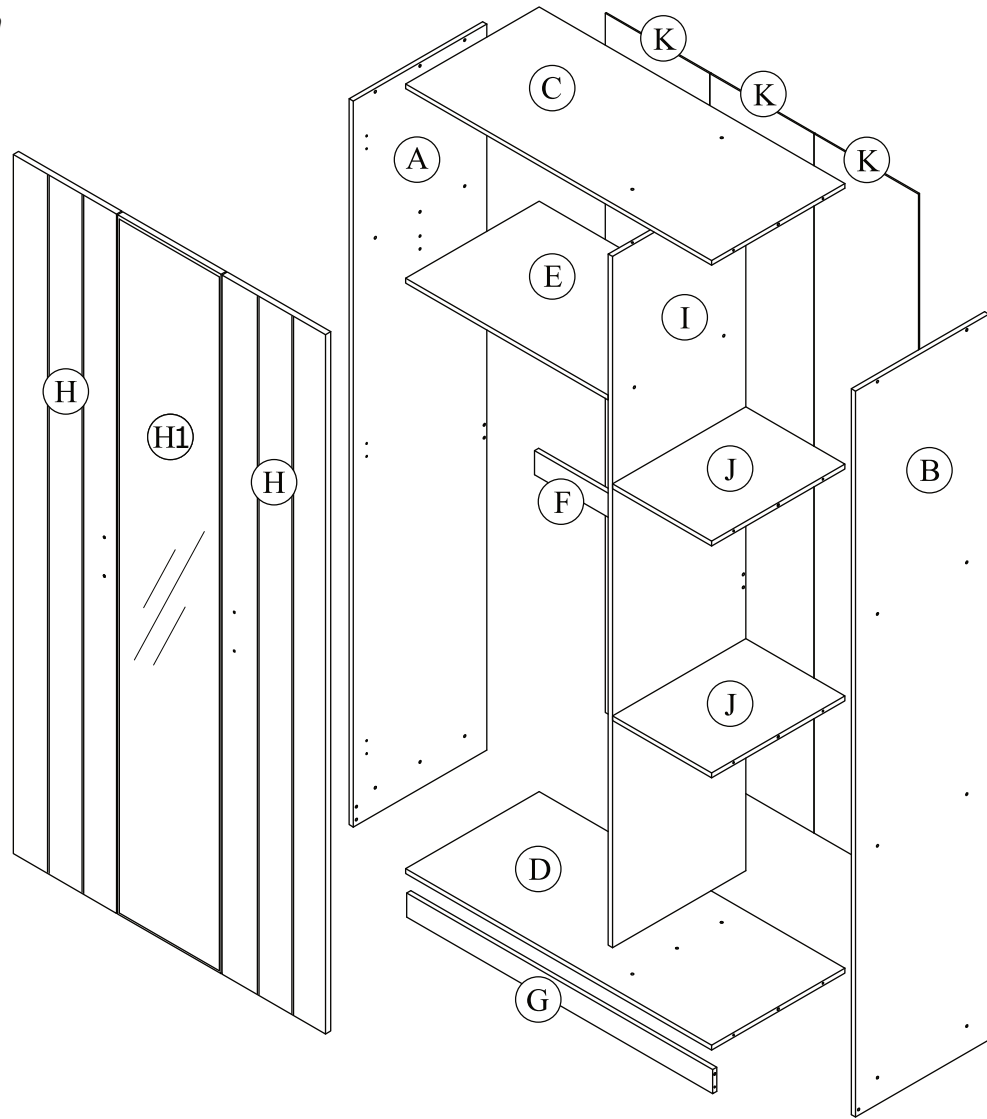



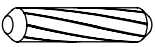
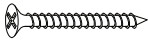

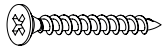

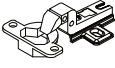
Person Required  
*Orang yang diperlukan*

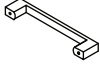

*Part List*  
*Senarai Bahagian*

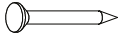

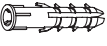
*Hardware List*  
*Senarai Perkakasan*

1	Dowel (D6x30mm)	2	Screw (M4.7X38mm)	3	Screw (M3.5x12mm)	4	Screw (M4X30mm)
							
	14 units		32 units		4 units		4 units
5	Screw (M10x12mm))	6	Hinges - 2/8"	7	Hinges - 5/8"	8	U Shape Handle (96mm)
							
	38 units		3 units		6 units		2 units
9	U Bracket	10	Hanger (572mm)	11	Metal L Bracket	12	Nail Leg
							
	2 units		1 unit		2 units		5 units
13	Nail Pin	14	Mounting L-Bracket	15	Wall Plug	16	Flat Washer
							
	20 units		2 units		2 units		2 units

## Special Tips for Door Alignment Tips Khas Untuk Pelarasan Pintu

A. Lateral adjustment (Moving door left-right) by screw adjusting

A. Pelarasan melintang (Gerakan pintu kiri-kanan) dengan melaraskan skru

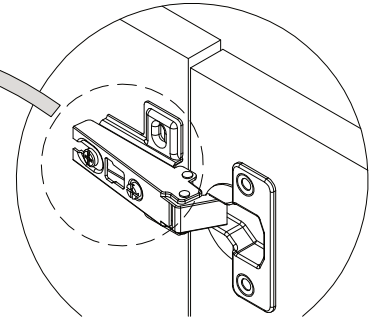
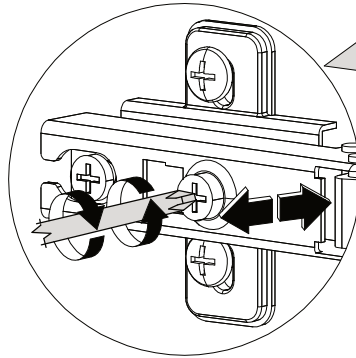
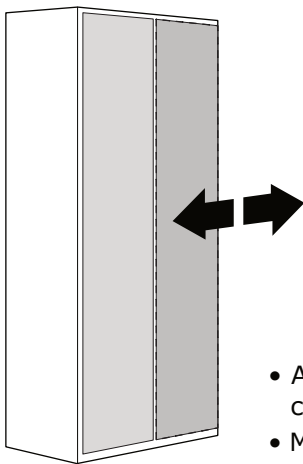

- Adjusting the screw by turning the screw clockwise or anti-clockwise
- Melaraskan skru dengan memutar skru mengikut arah jam atau lawan arah jam

- Please follow the hinges supplied
- Sila ikut engsel yang dibekalkan

B. Vertical adjustment (Moving door up-down) via the slot on the mounting plate

B. Pelarasan menegak (Gerakan pintu atas-bawah) melalui slot pada plat pemasangan

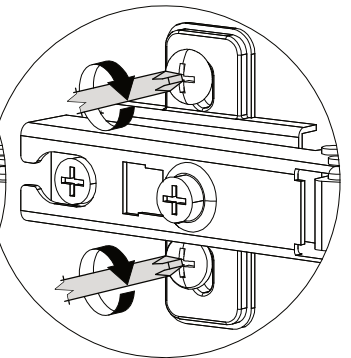
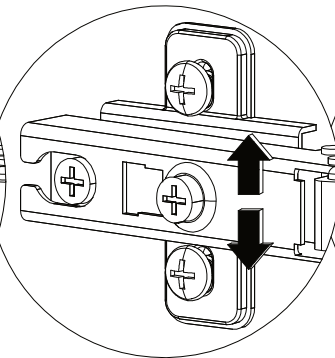
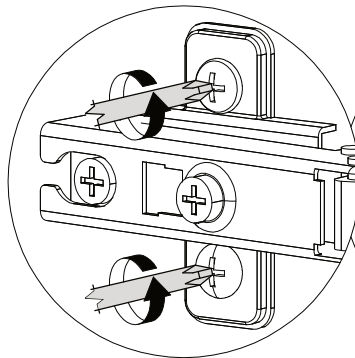
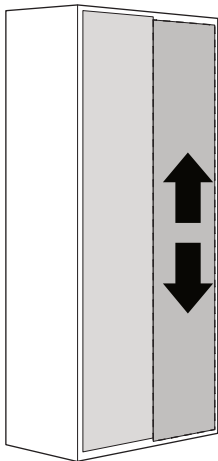

- Untighten both screw
- Longgarkan kedua-dua skru
- Move door up or down
- Laraskan pintu ke atas atau bawah
- Tighten back both screw
- Ketatkan semula kedua-dua skru

C. Front-to-back adjustment (Spacing Door Off Cabinet) by slacking the hinge arm mounting screw

C. Pelarasan depan-ke-belakang (Penjarakan pintu dari kabinet) dengan melonggarkan skru pemasangan pada lengan engsel

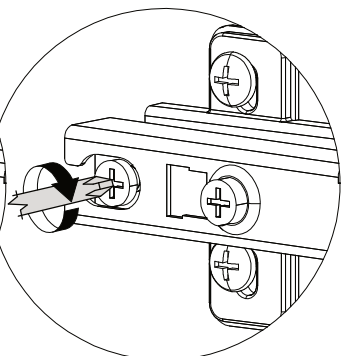
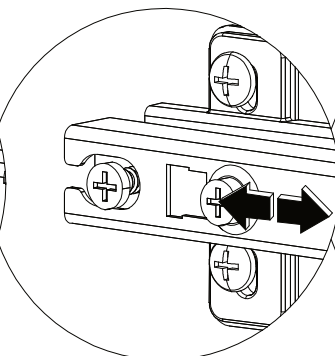
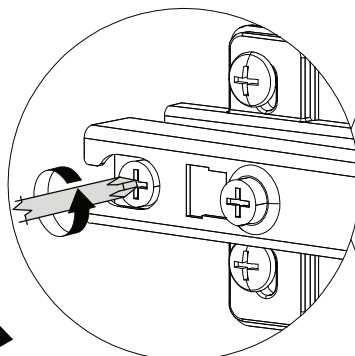
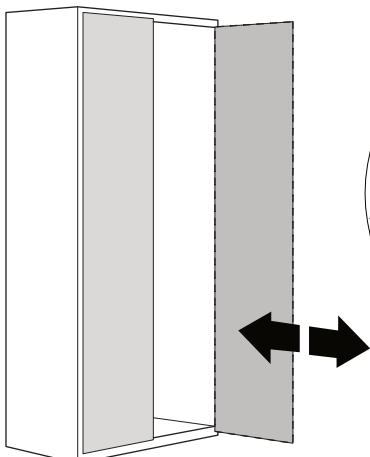

- Untighten screw
- Longgarkan skru
- Move door front or back
- Laraskan pintu ke depan atau belakang
- Tighten back screw
- Ketatkan semula skru

# STEP 1

1		6 units
---	--	---------

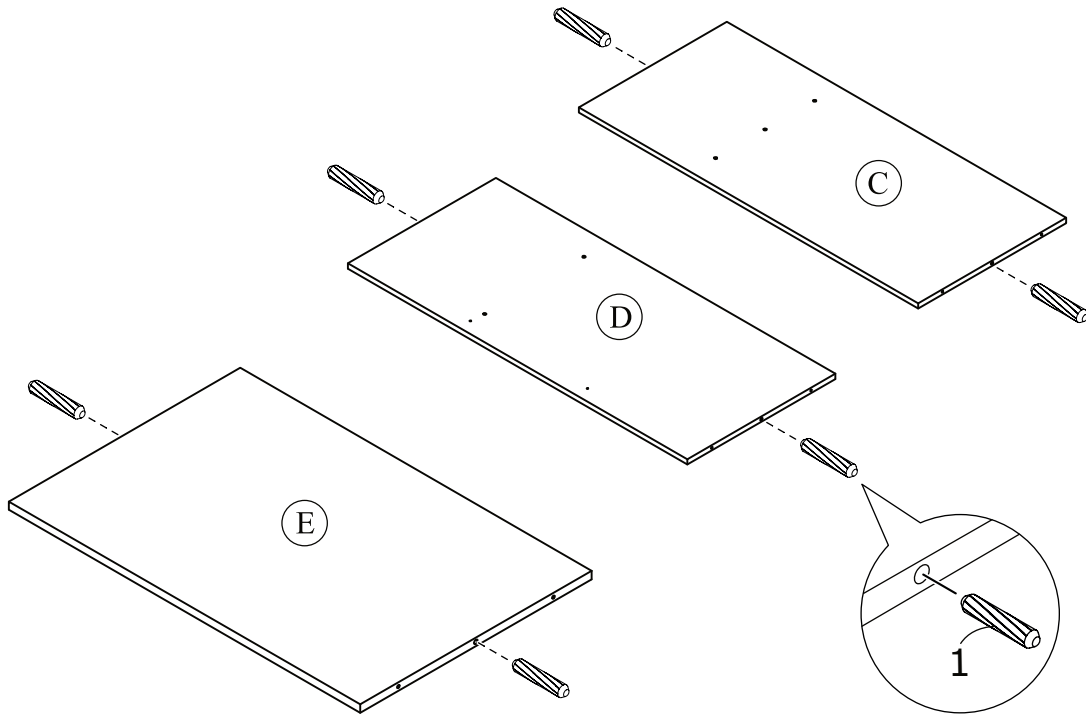

# STEP 2

1		8 units
---	---	---------

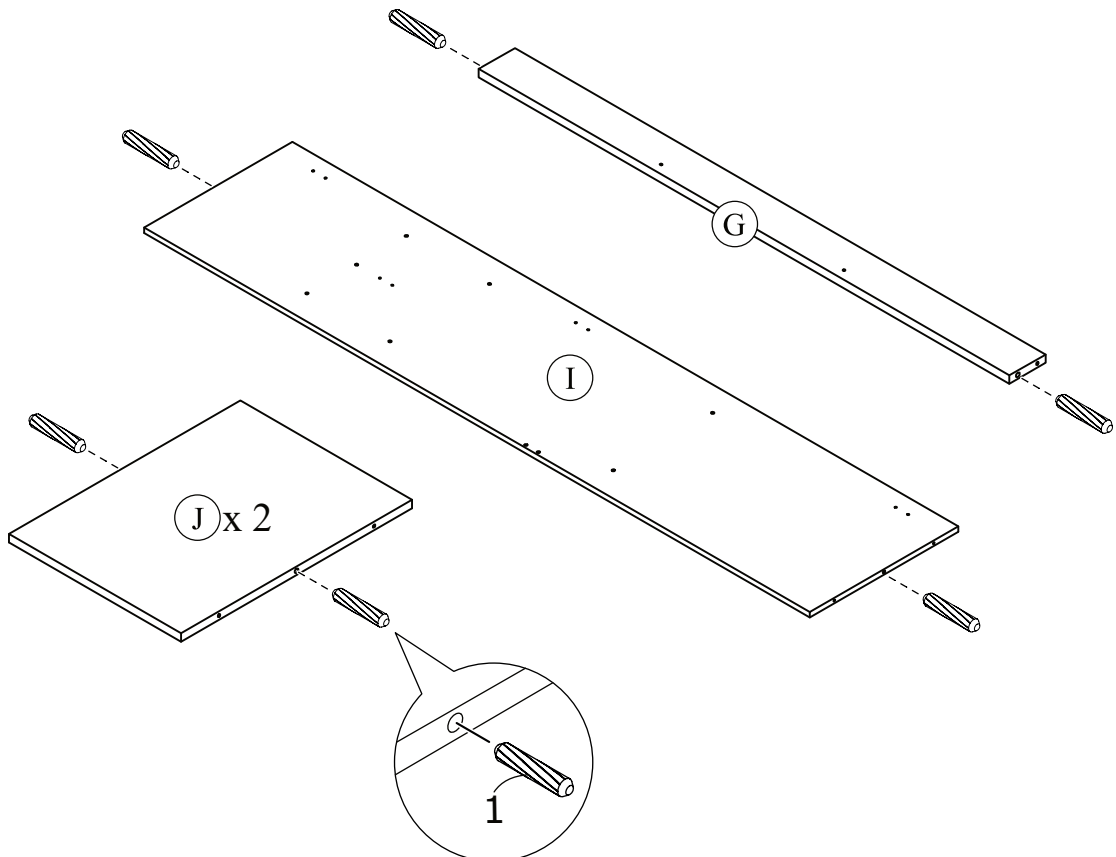

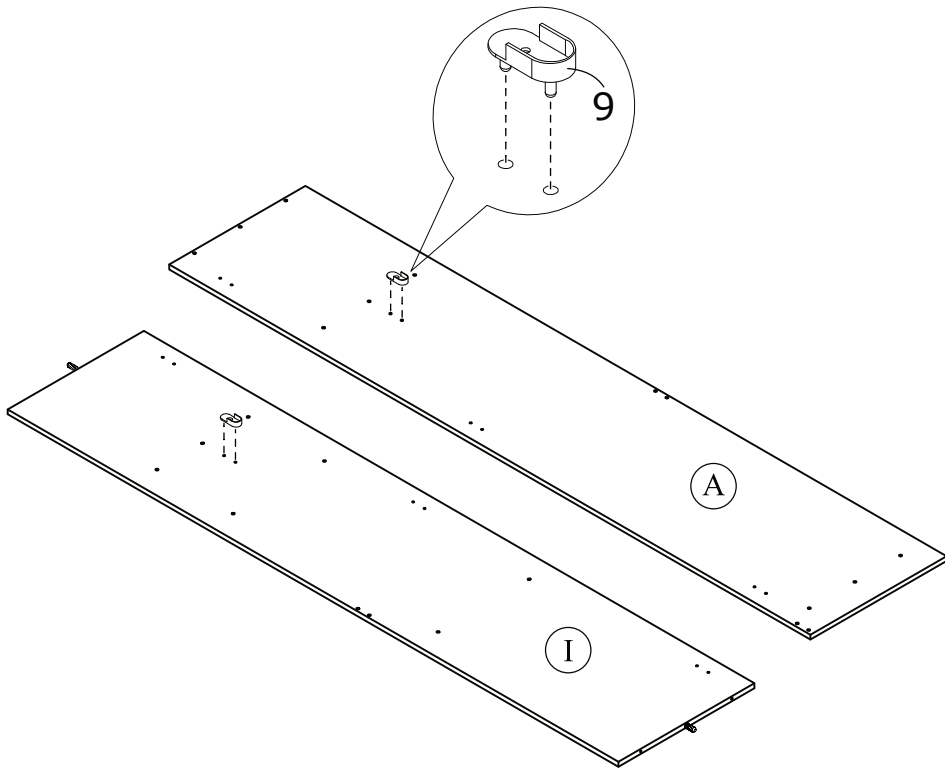

# STEP 3

9		2 units
---	--	---------



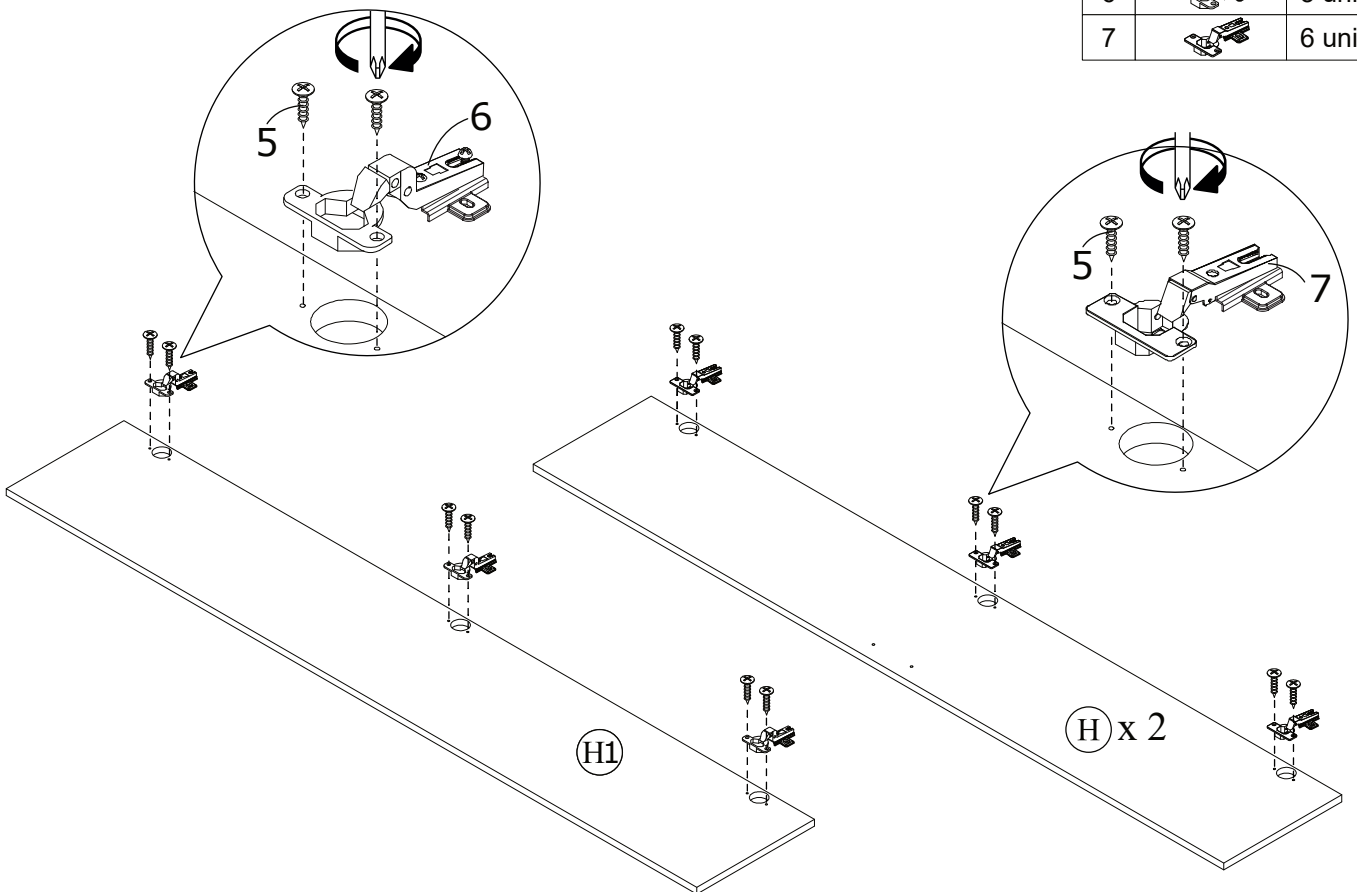

# STEP 4

5		18 units
6		3 units
7		6 units



# STEP 5

3		2 units
11		2 units

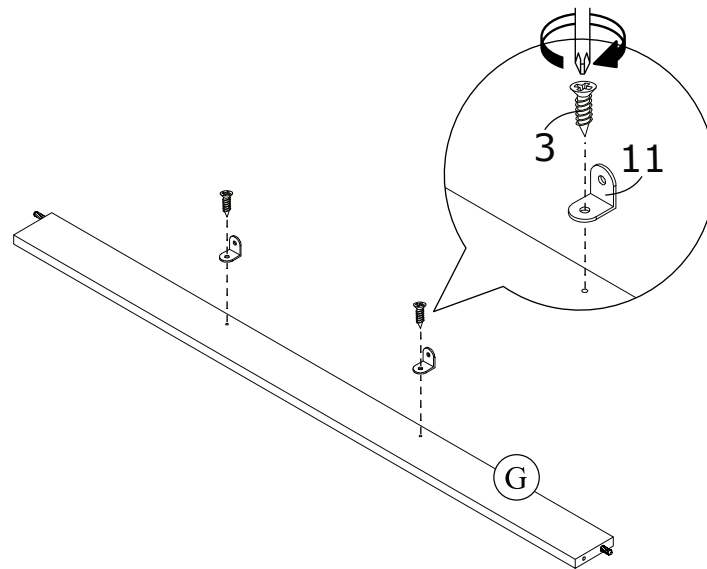

# STEP 6

3		2 units
---	---	---------

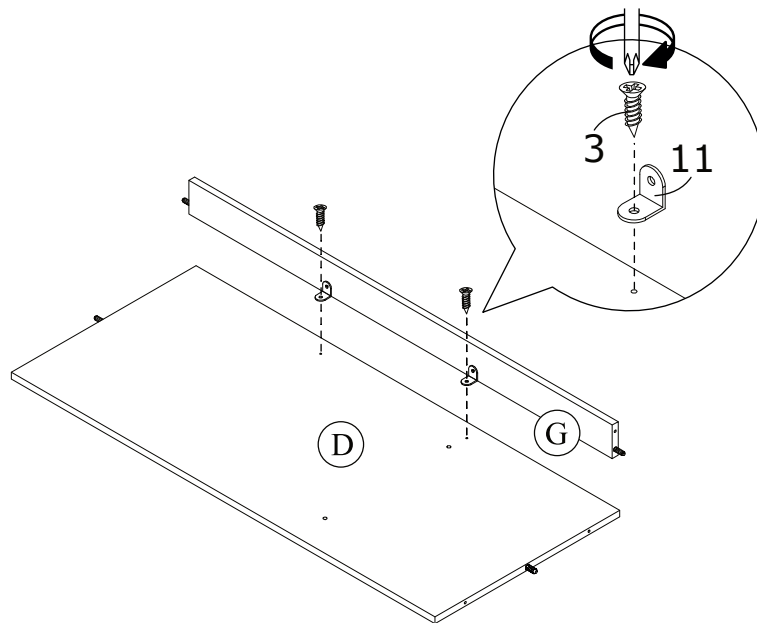

# STEP 7

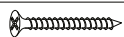
2		2 units
---	---	---------

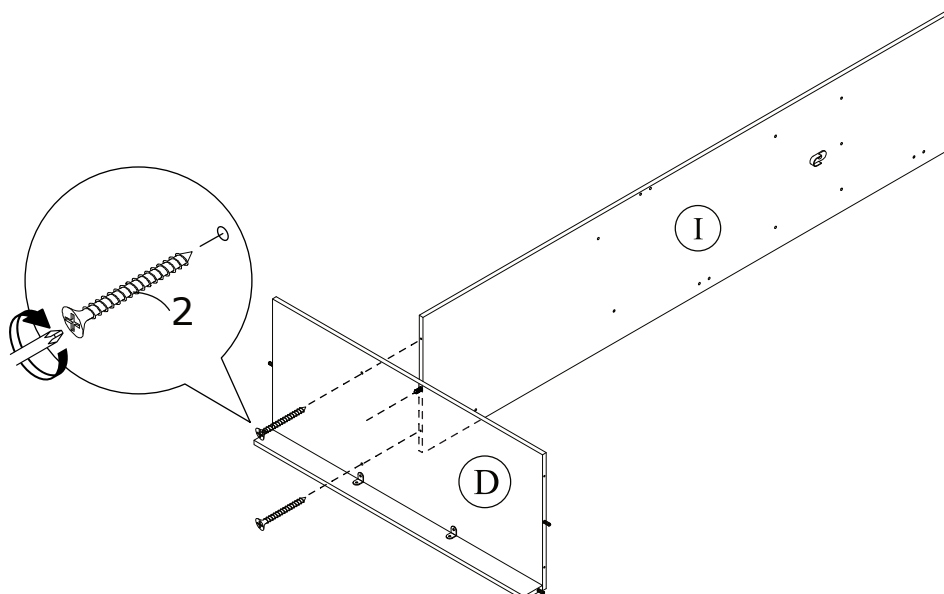

# STEP 8

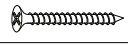
2		6 units
---	--	---------

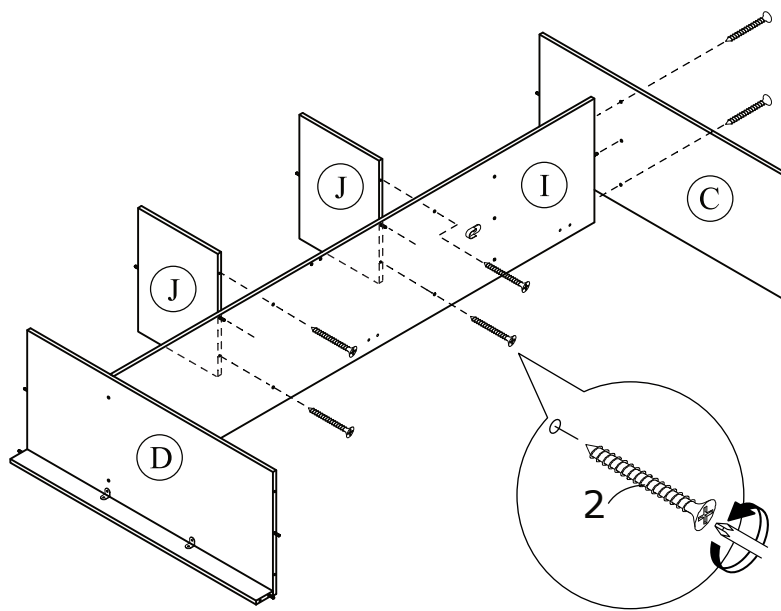

# STEP 9

2		11 units
---	---	----------

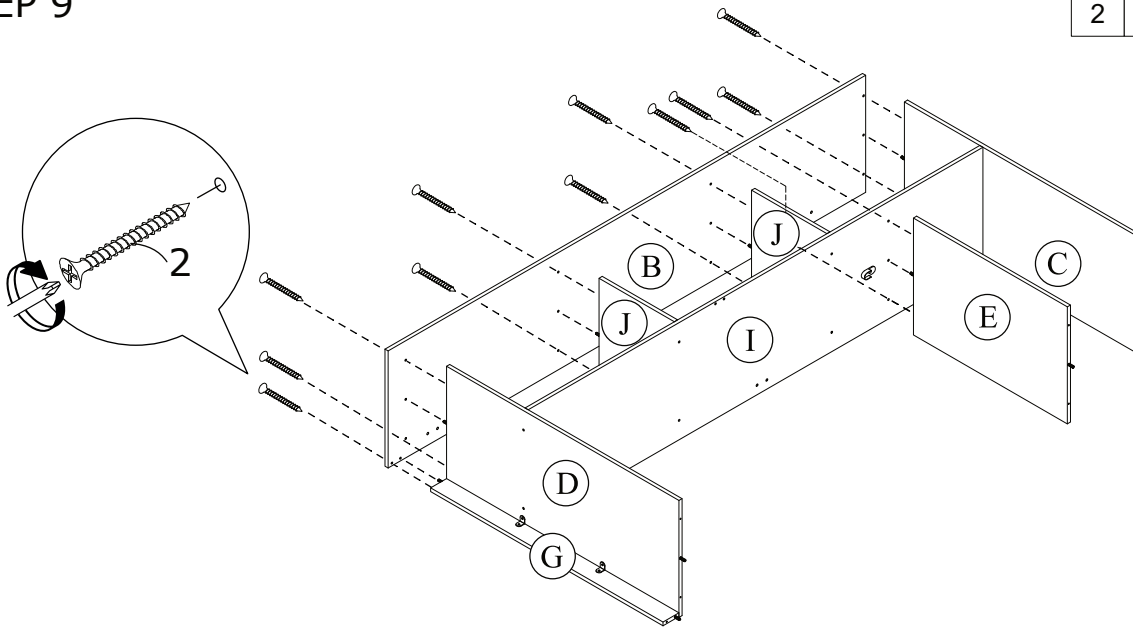

# STEP 10

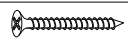
2		11 units
---	---	----------

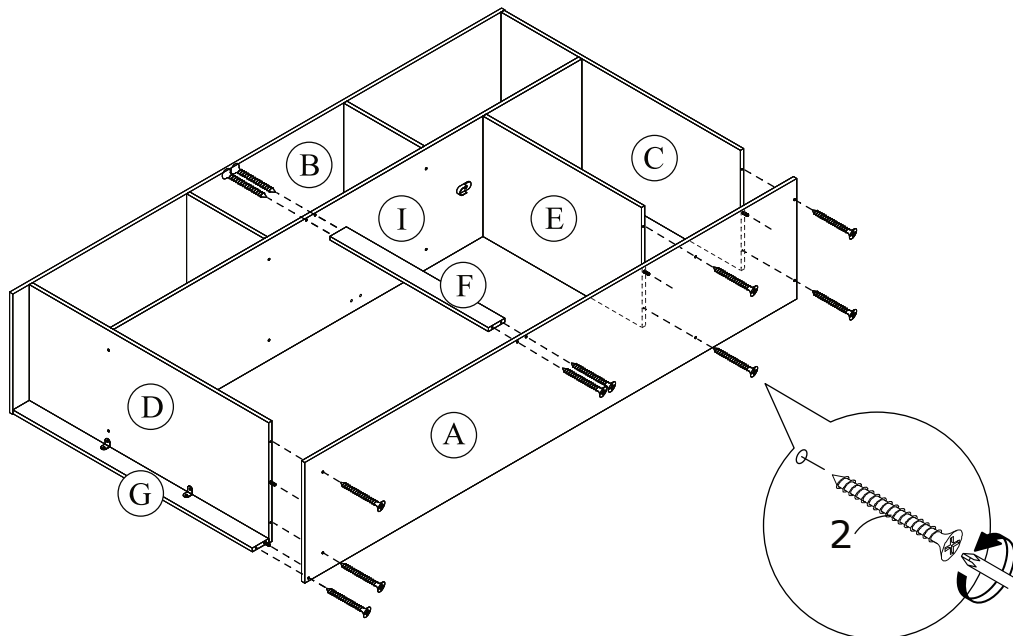

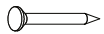

# STEP 11

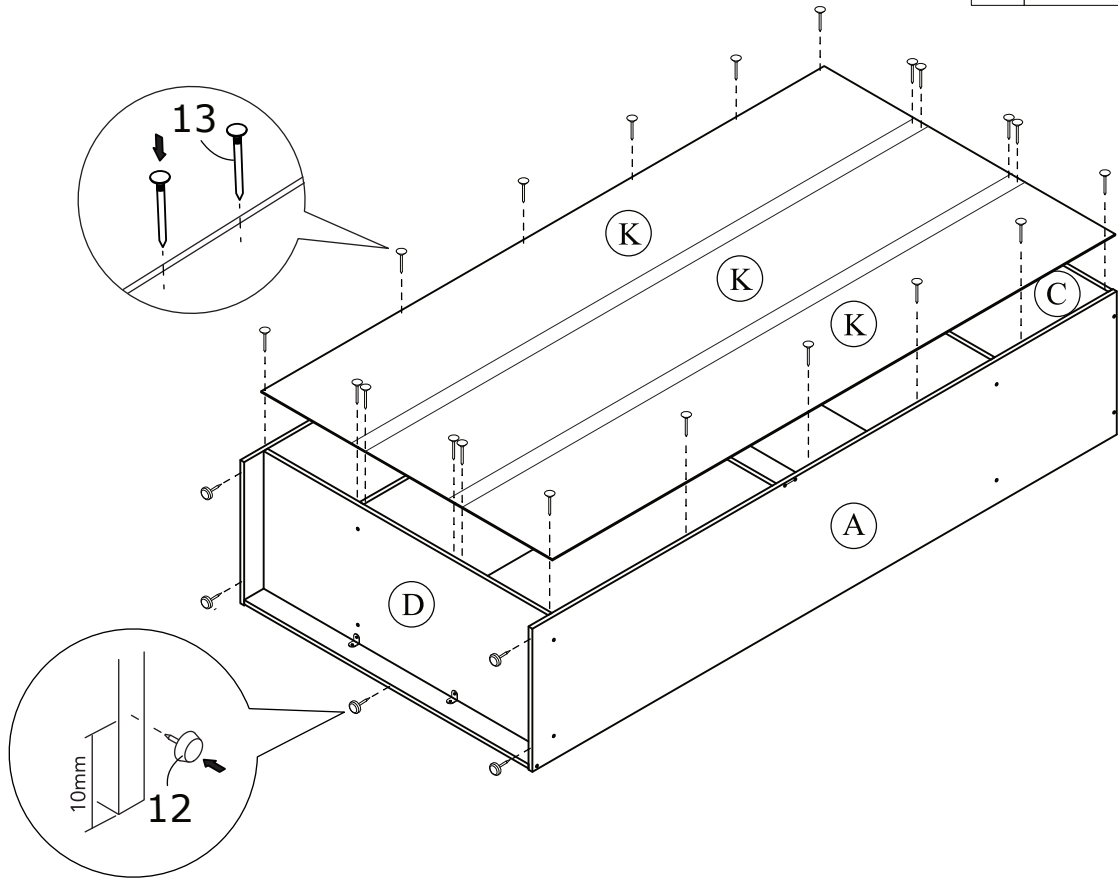
12		5 units
13		20 units





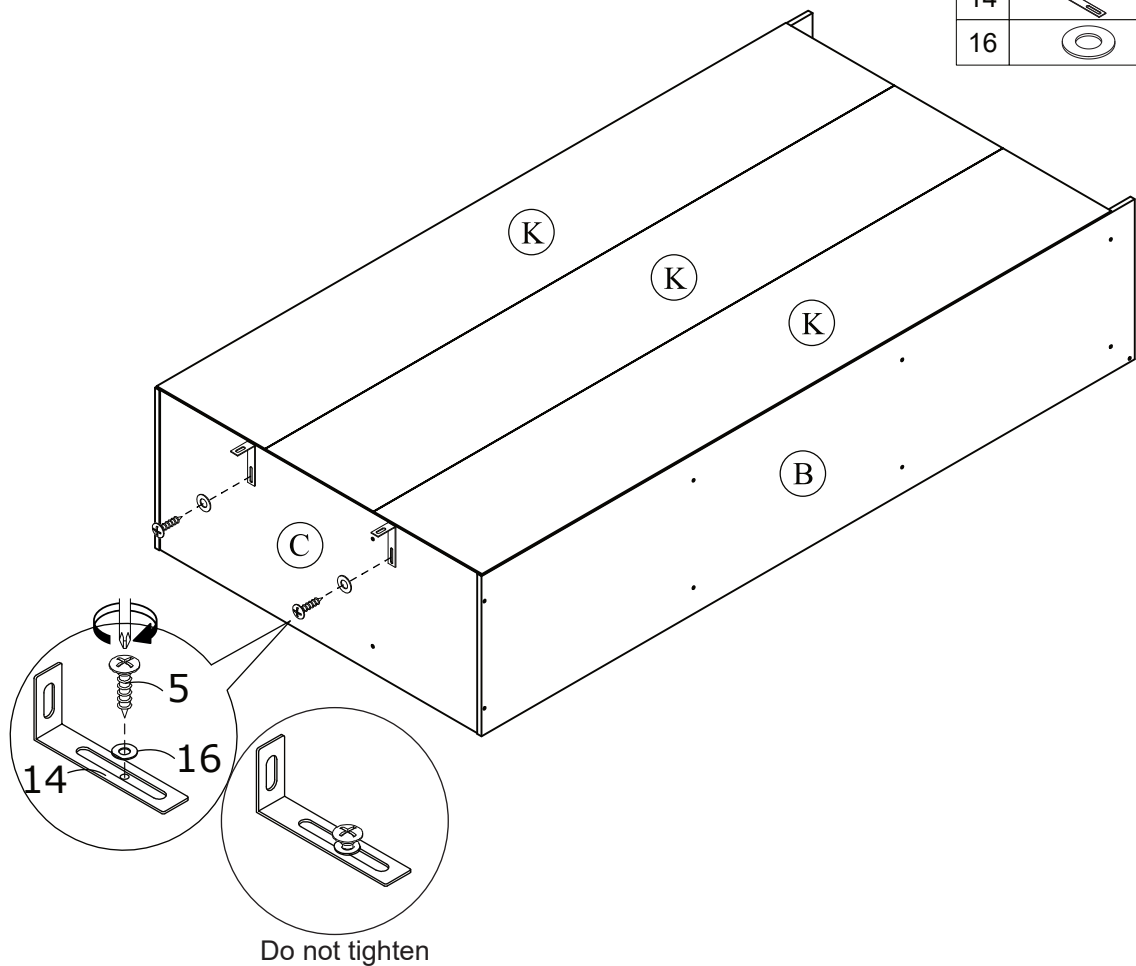

# STEP 12

5		2 units
14		2 units
16		2 units





# STEP 13

5		12 units
4		4 units
8		2 units
10		1 unit

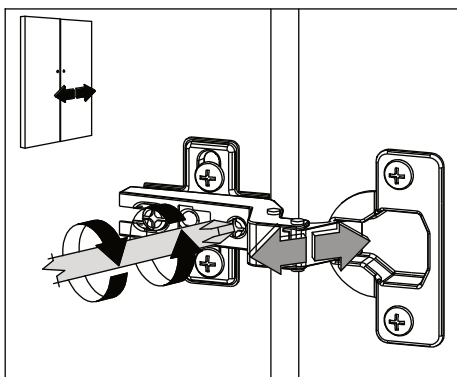
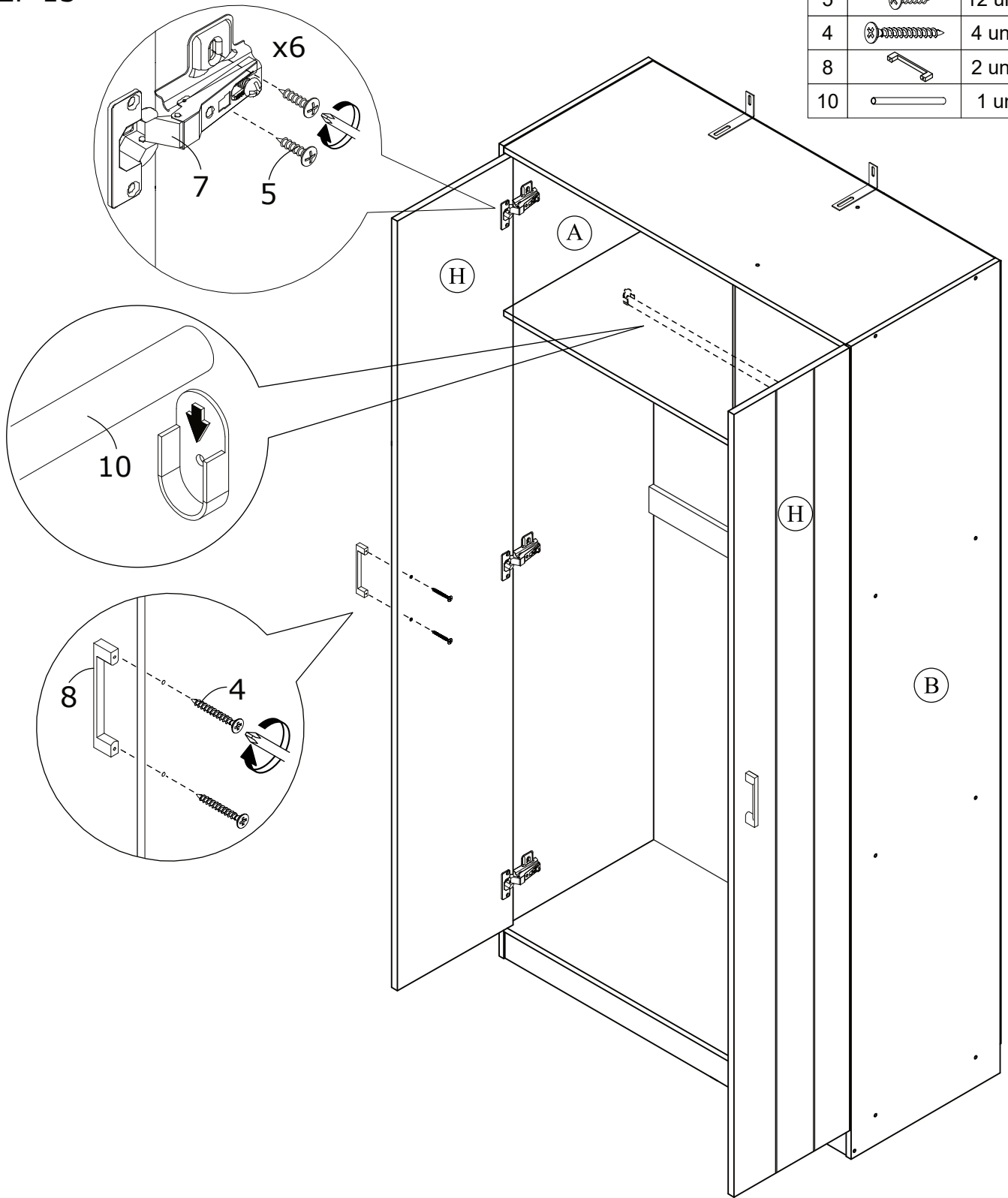

A. Lateral adjustment (Moving Door Left-Right) by screw adjusting

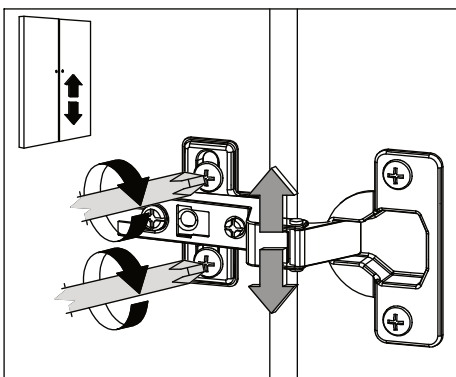

B. Vertical adjustment (Moving Door Up-Down) via slot in the mounting plate

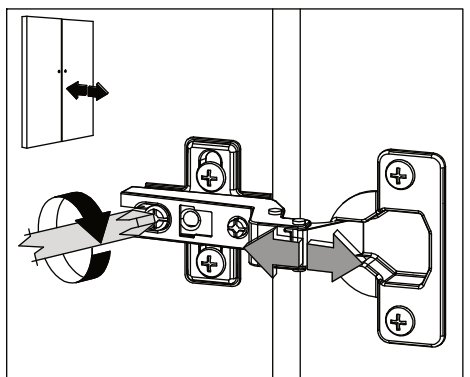

C. Front-to-back adjustment (Spacing Door Off Carcas) by slacking the hinge arm mounting screw

# STEP 14

5		6 units
---	--	---------

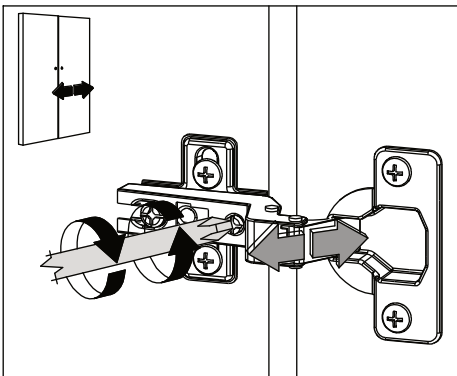
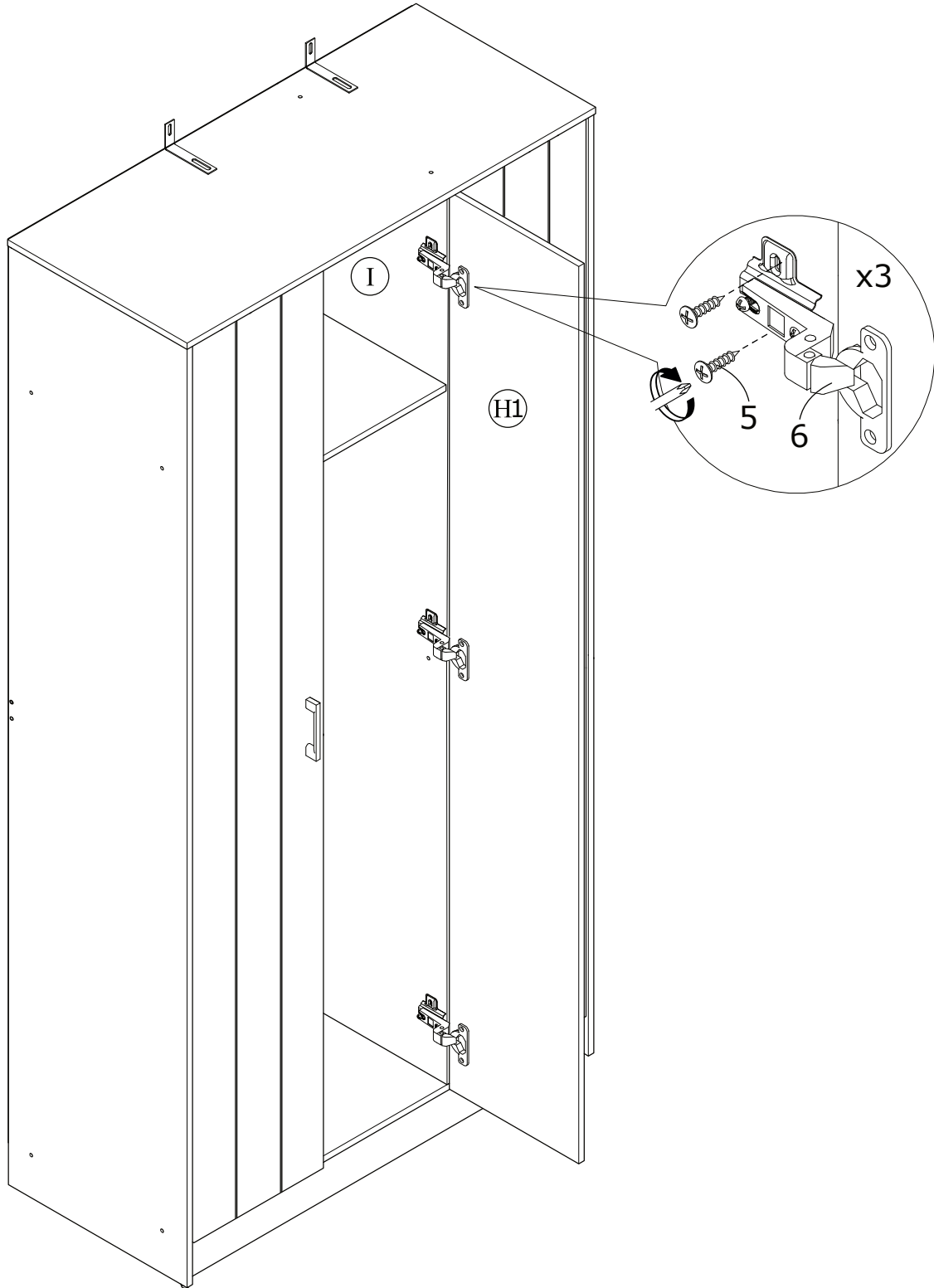

A. Lateral adjustment (Moving Door Left-Right) by screw adjusting

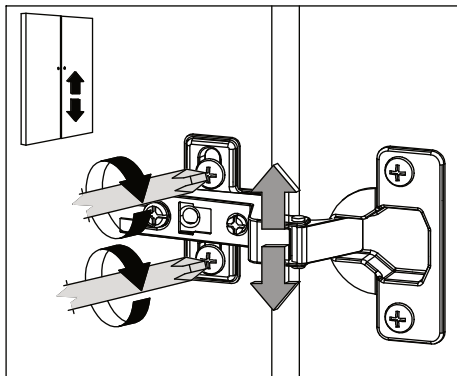

B. Vertical adjustment (Moving Door Up-Down) via slot in the mounting plate

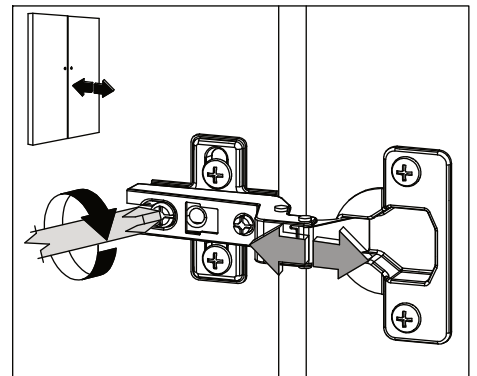

C. Front-to-back adjustment (Spacing Door Off Carcas) by slacking the hinge arm mounting screw

## STEP 15

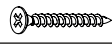
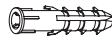
2		2 units
15		2 units

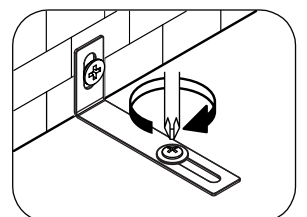
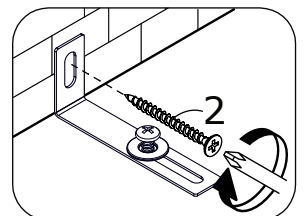
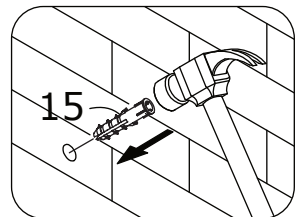
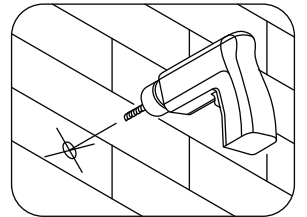
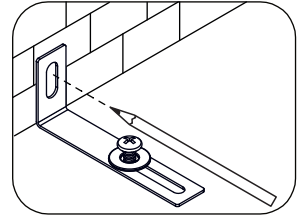
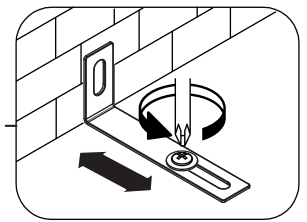
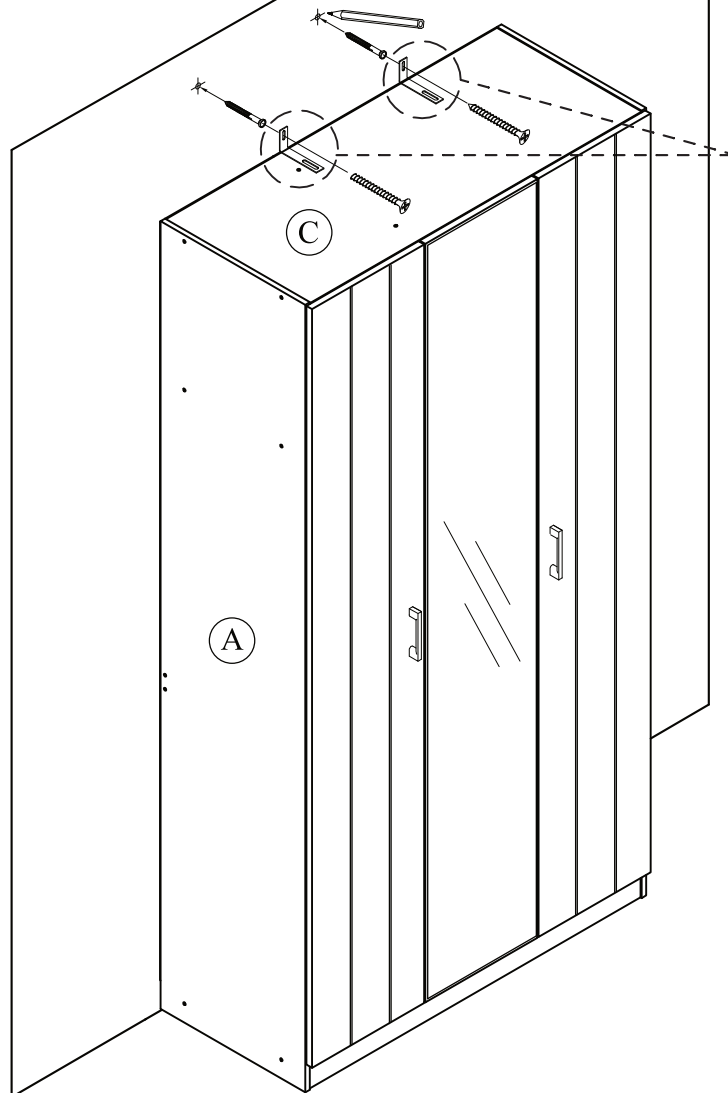
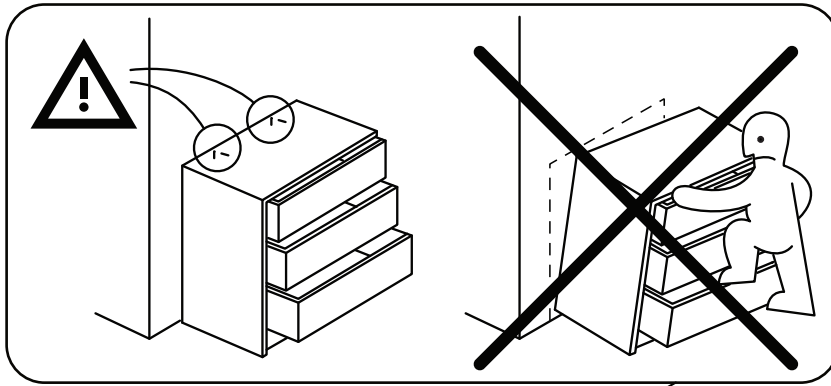

**NOTE :** Wall fixing that supplied with this product is general purpose wall plug only. As different wall materials require different types of fixing hardware. You must use fixing hardware suitable for the type of wall you intend to mount this product to.

Please ensure that the head of any screw used has a greater diameter than the diameter of the mounting hole on the product and that the fixing is safe and secure before use.

**PERINGATAN :** *Palam dinding yang disertakan dengan produk ini adalah untuk tujuan am sahaja. Oleh kerana bahan dinding yang berbeza memerlukan palam dinding yang berbeza. Anda perlu memastikan palam dinding yang sesuai digunakan untuk memasang produk di dinding yang diingini.*

*Pastikan diameter kepala skru yang digunakan adalah lebih besar daripada diameter lubang pendakap pada produk dan juga palam dinding adalah kukuh dan selamat sebelum digunakan.*

# Maximum Load Beban Maksimum

This unit has been designed to support the maximum loads shown. Exceeding these load limits could cause sagging, instability, product collapse, and/or serious injury

*Unit ini telah direka bentuk untuk menyokong beban maksimum yang ditunjukkan. Melebihi had beban ini boleh menyebabkan kendur, ketidakstabilan, keruntuhan produk dan/atau kecederaan serius.*

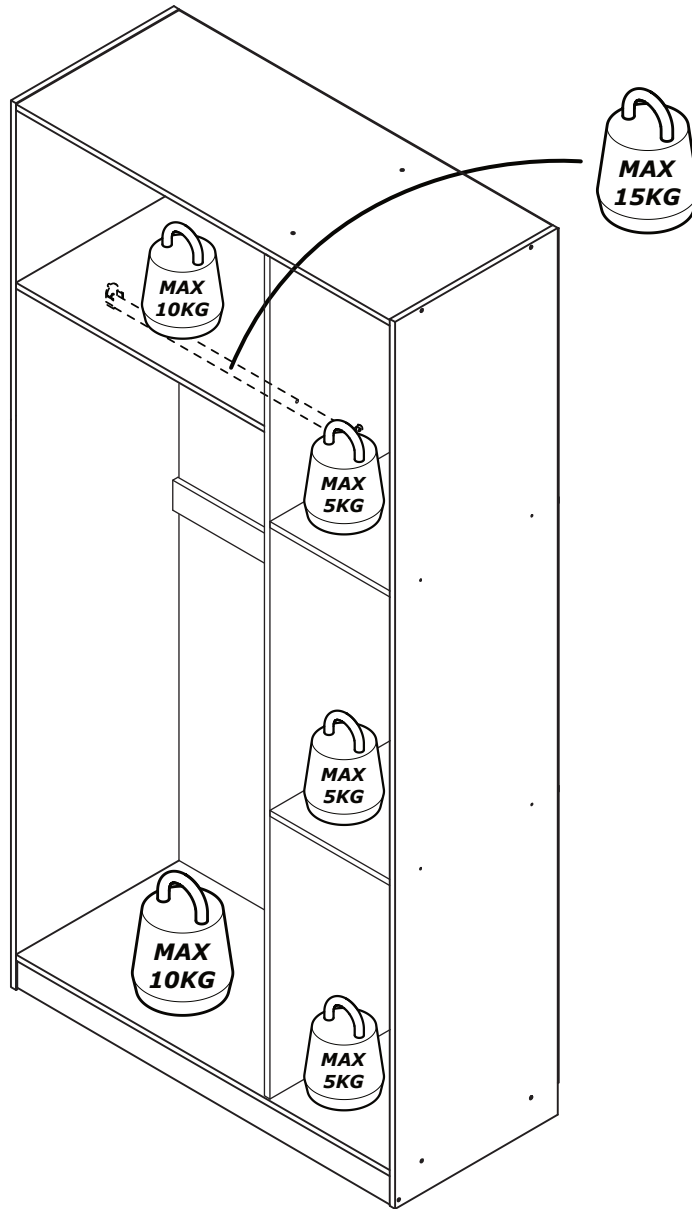

## WARNING

Serious or fatal injuries can occur from falling furniture.  
To prevent furniture from falling, please do:

- Install the tipover restraint provided.
- Place heaviest items in the lowest drawers.
- Unless specifically designed, do not place TVs or other heavy object on top of the furniture.
- Do not let children climb or hang on drawers, doors, or shelves.
- Do not open more than one drawer at a time.
- Do not remove the drawer interlock systems.

**The use of tip over restraints may only reduce and not eliminate the risk of falling furniture.**

## AMARAN

Kecederaan serius atau maut boleh berlaku akibat perabot yang jatuh. Untuk mengelakkan perabot daripada jatuh, sila lakukan:

- Pasang peranti penahan jatuh yang disediakan.
- Letakkan barang yang paling berat di dalam laci paling rendah.
- Melainkan direka bentuk khusus, jangan letakkan TV atau objek berat lain di atas perabot.
- Jangan biarkan kanak-kanak memanjat atau bergantung pada laci, pintu atau rak.
- Jangan buka lebih daripada satu laci pada satu masa
- Jangan tanggalkan sistem saling kunci laci.

**Penggunaan peranti penahan jatuh hanya boleh mengurangkan dan tidak menghapuskan risiko perabot jatuh.**