

CASANOVO

ANTELAO 100P160

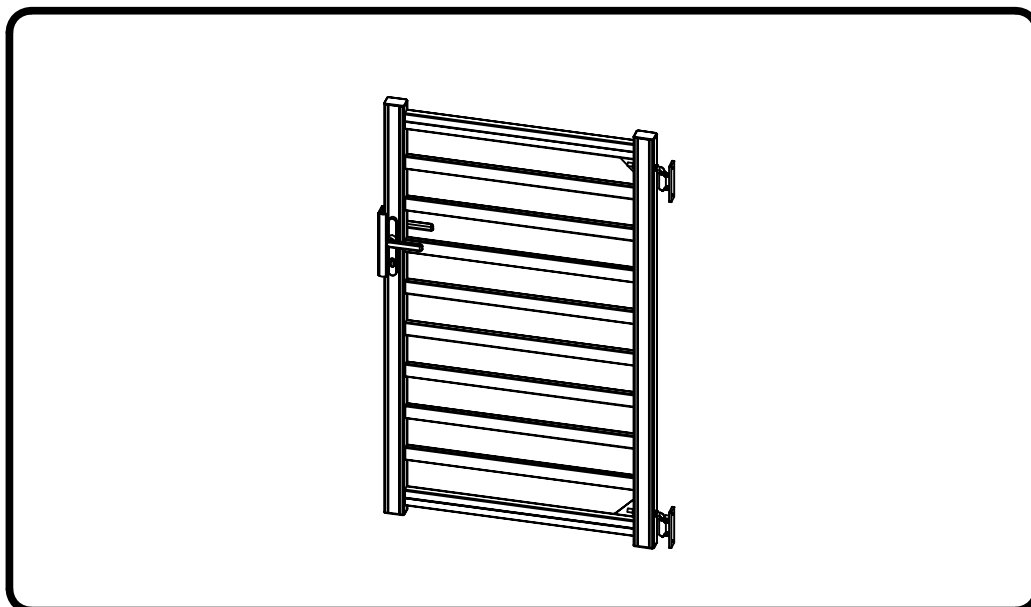

2-5H



x2

STI-000085

[x1]

FR

EN

ES

DE

IT

NL

PL

PT

FI

SE





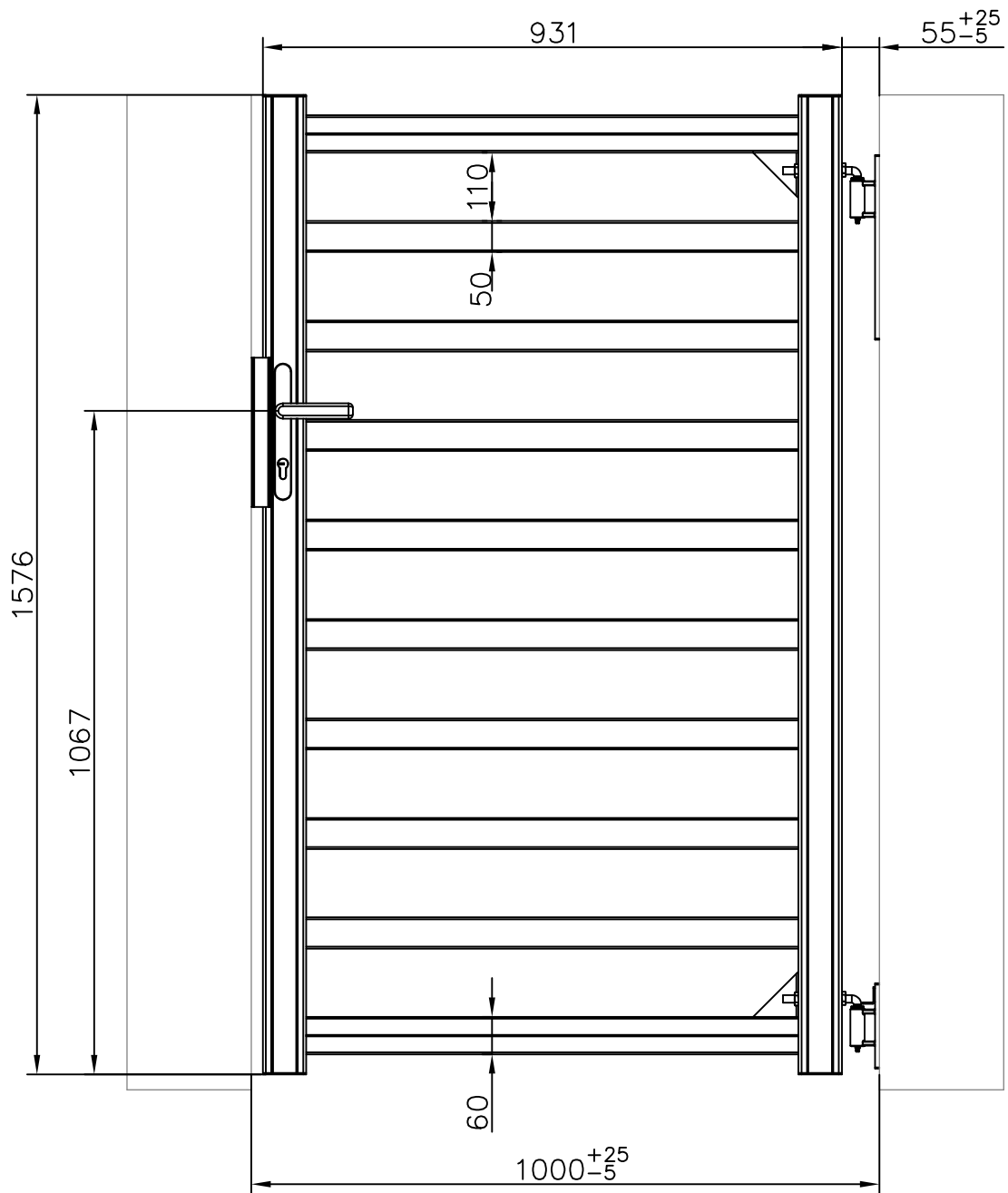

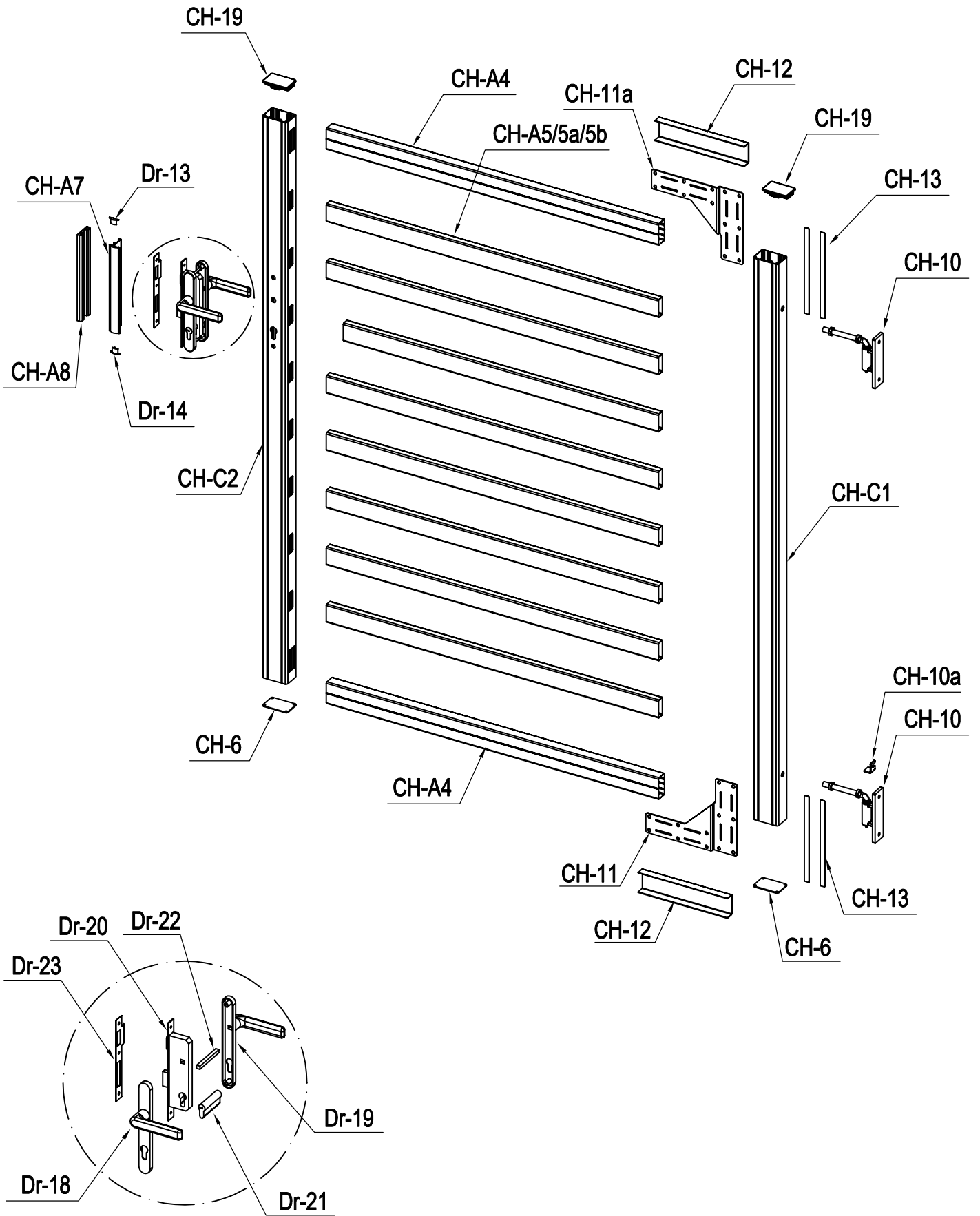























DK











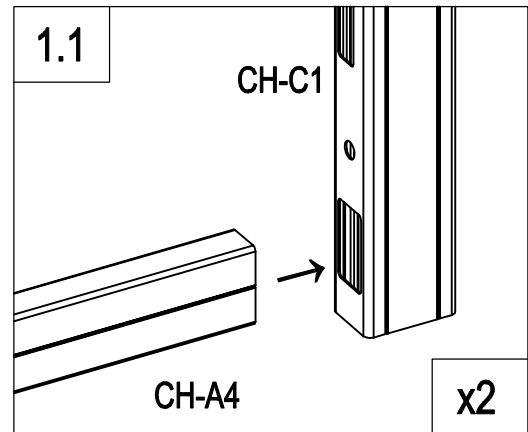
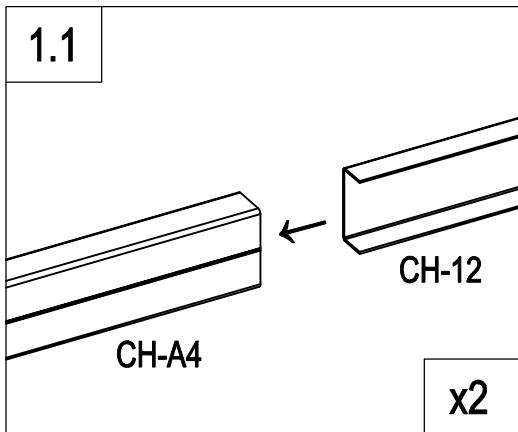
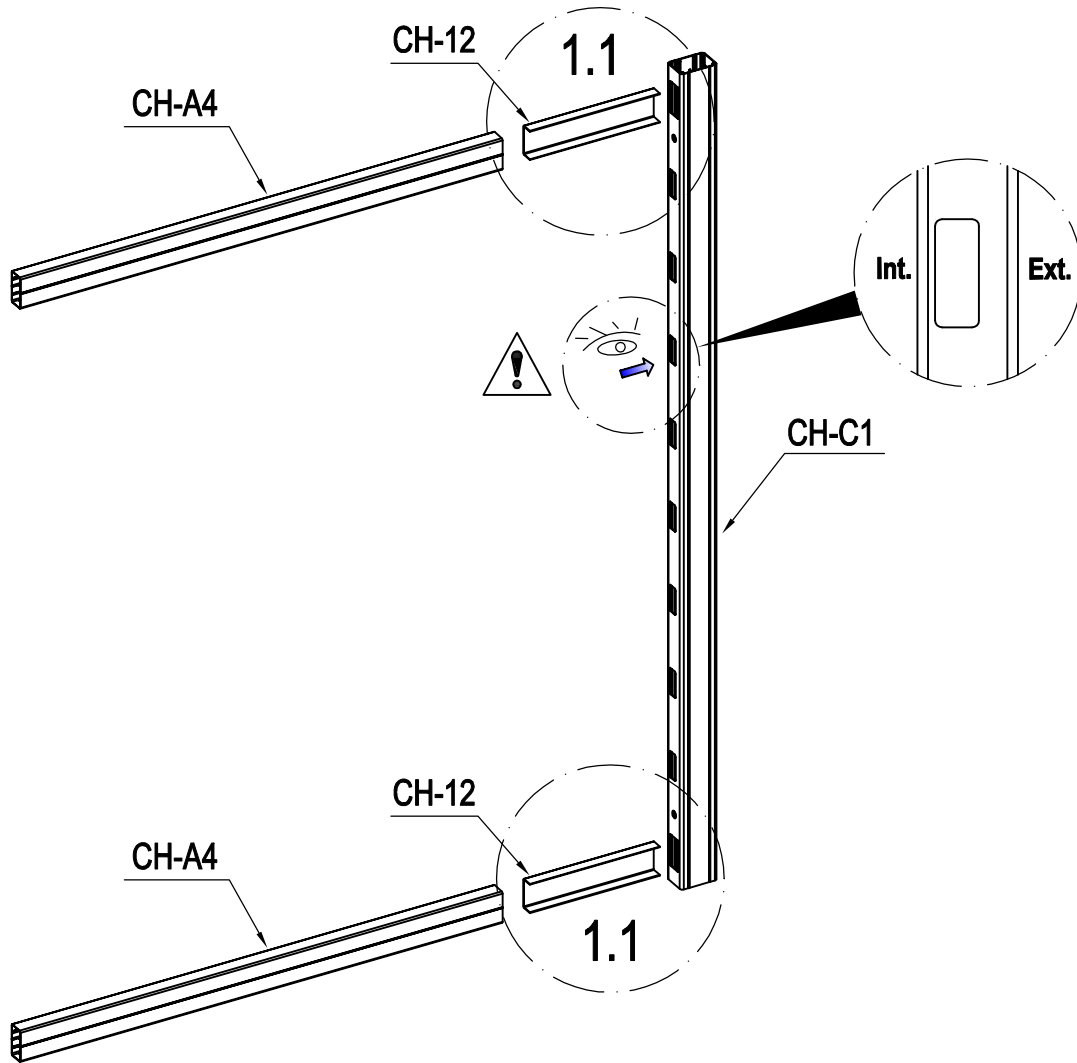

PART LIST

IMAGE	NO.	L.(mm)	QTY	IMAGE	NO.	L.(mm)	QTY
	CH-C1	1570	1		Dr-25	M5x45	1
	CH-C2	1570	1		Dr-25a	M5x60	2
	CH-A4	928	2		Dr-26	ST4x12	3
	CH-A5	927	6		Dr-27	ST4x24	2
	CH-A5b	881	1		CH-A30	ST6x25	28
	CH-A5a (+CH-A12)	927	1		CH-A31	ST4x10	8
	CH-A7	240	1		CH-A32	ST6x40	4
	CH-A8	240	1		CH-A33	M6x50	2
	CH-6		2				
	CH-10		2				
	CH-10a		1				
	CH-11		1				
	CH-11a		1				
	CH-12		2				
	CH-13		4				
	Dr-13		1				
	Dr-14		1				
	Dr-30		2				
	CH-19		2				
	Dr-18		1				
	Dr-19		1				
	Dr-20		1				
	Dr-21		1				
	Dr-22		1				
	Dr-23		1				



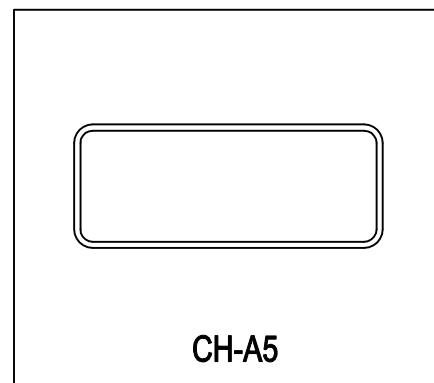
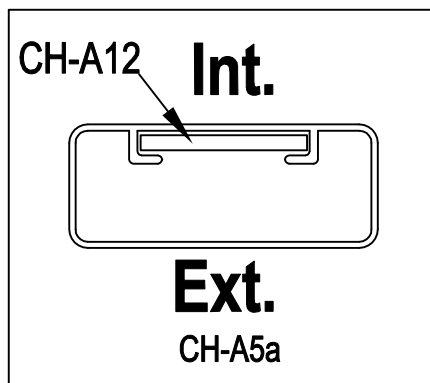
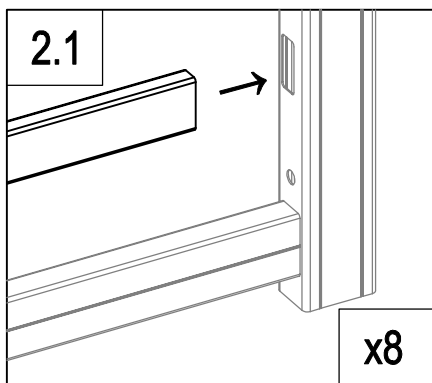
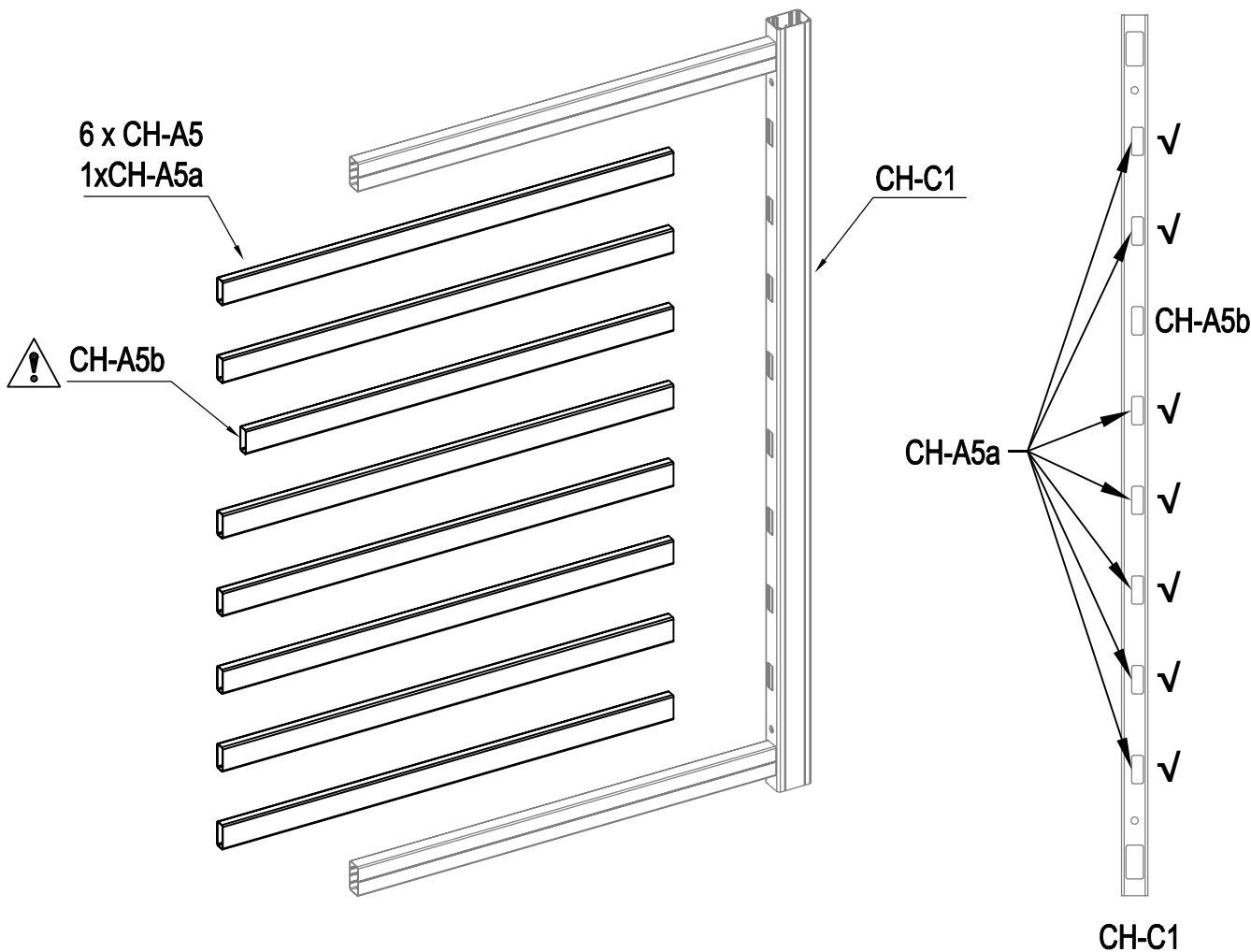

	CH-C1	1
	CH-A4	2
	CH-12	2

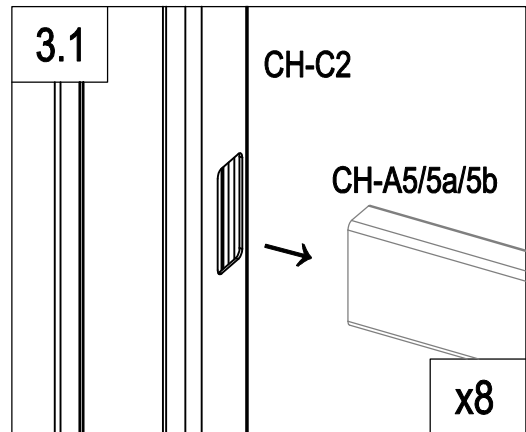
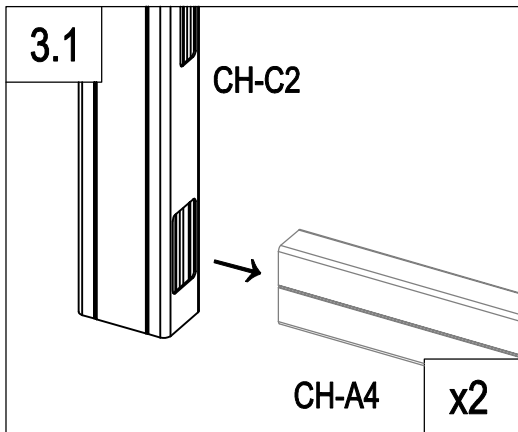
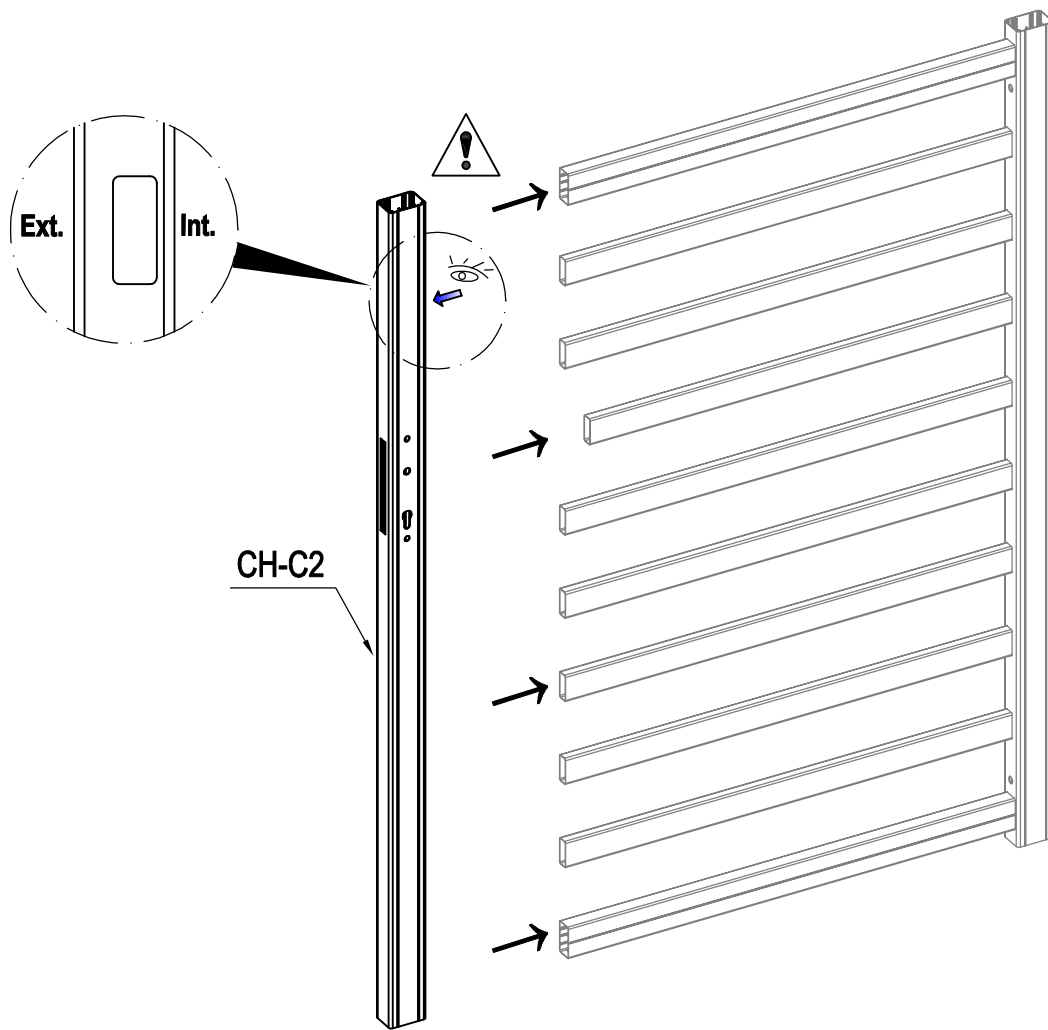

	CH-A5	6
	CH-A5b	1
	CH-A5a (+CH-A12)	1

EN: reinforced slat for automation
 FR: lame renforcée pour l'automatisation
 DE: verstärkte Lamelle für die Automatisierung
 ES: Lámina reforzada para la automatización
 PT: ripa reforçada para automatização
 IT: lamella rinforzata per l'automazione
 NL: versterkte lat voor automatisering
 PL: wzmocniona listwa do automatyzacji
 FI: vahvistettu säeikköautomaatiota varten
 SE: förstärkt lamell för automatisering
 DK: forstærket lamel til automatisering





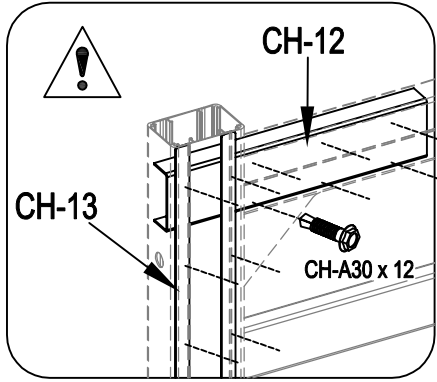
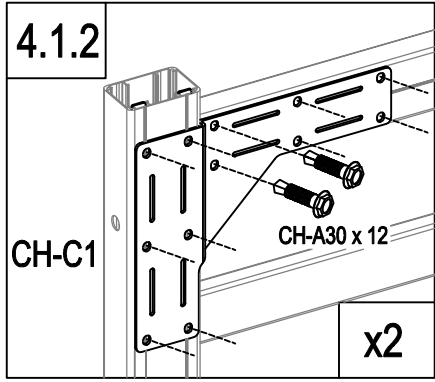
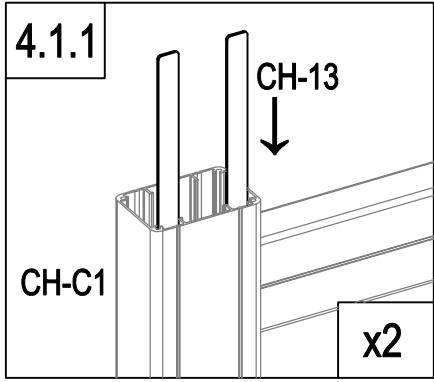
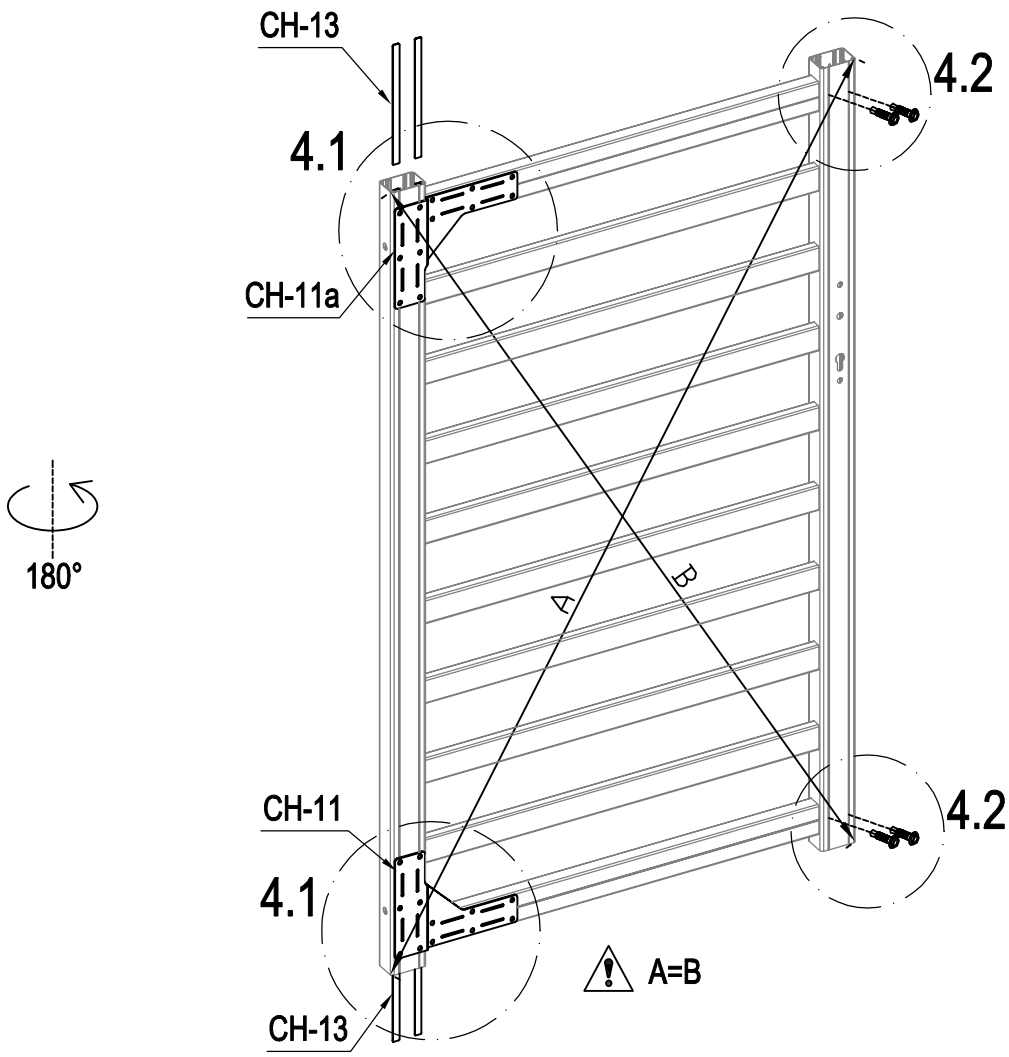

	CH-C2	1
---	-------	---

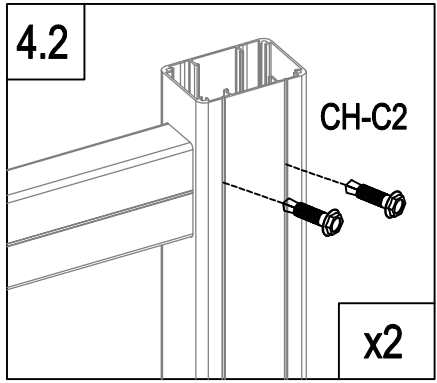
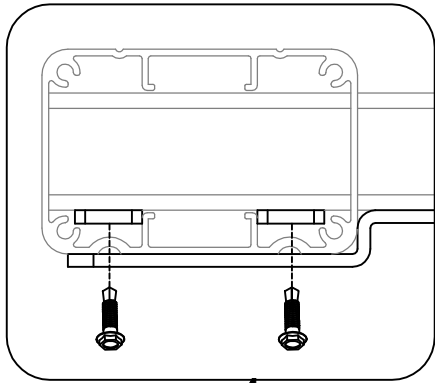

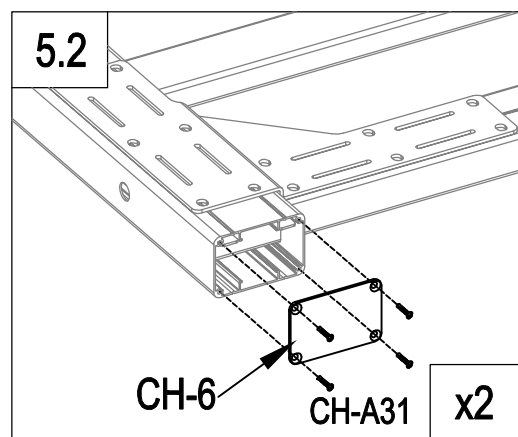
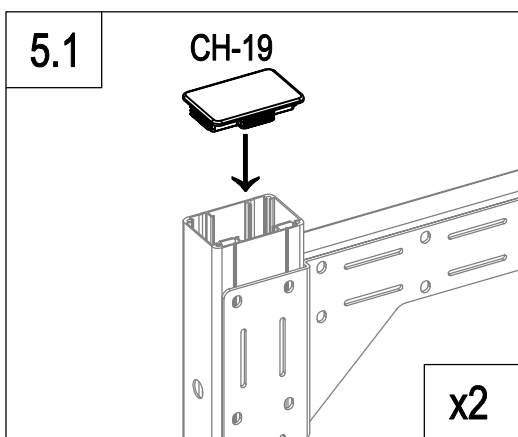
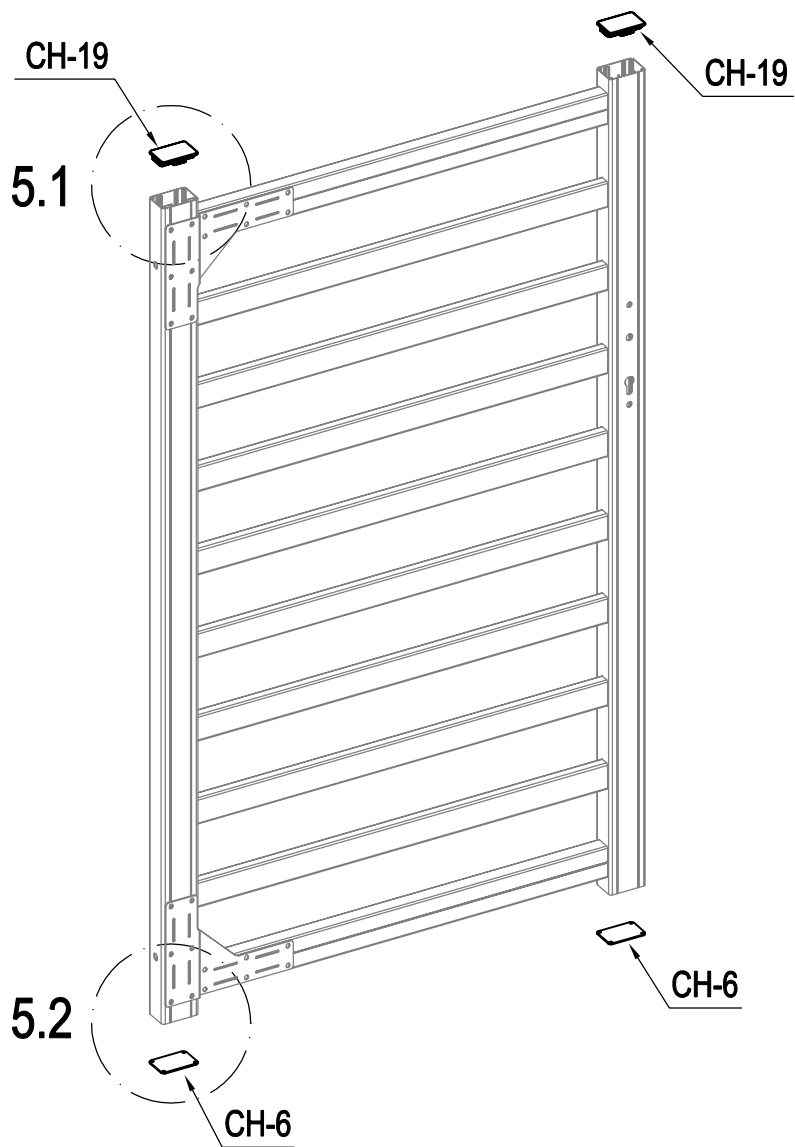



	CH-13	4
	CH-11	1
	CH-11a	1
	CH-A30	28



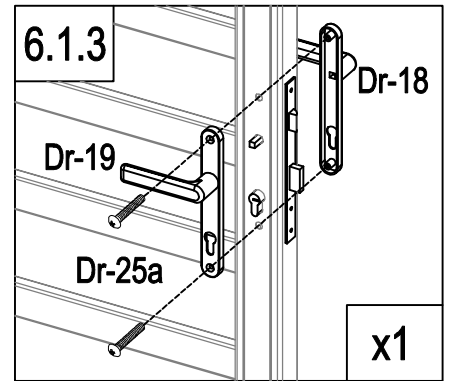
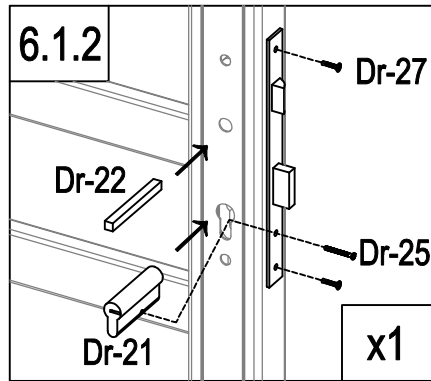
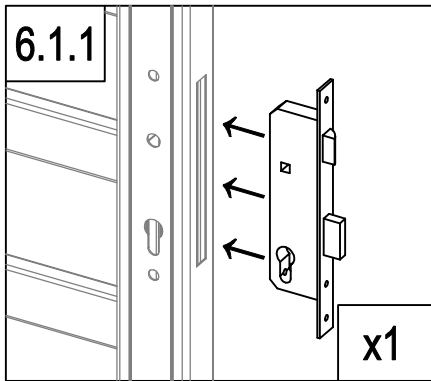
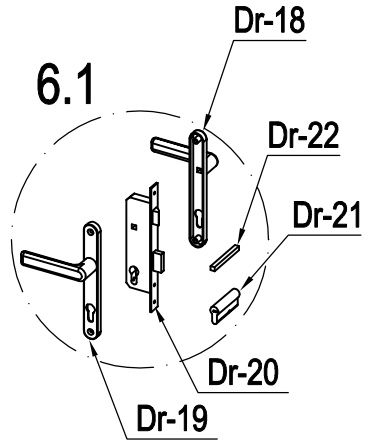
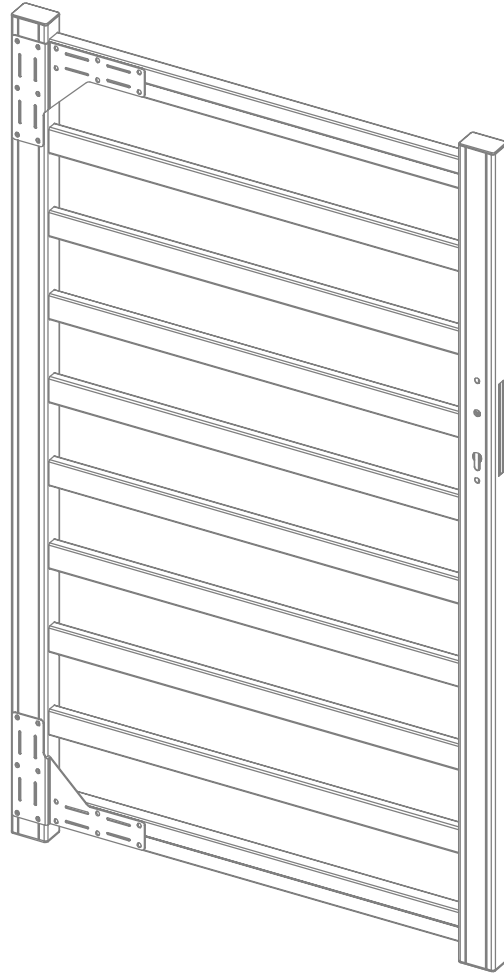







	CH-6	2
	CH-19	2
	CH-A31	8





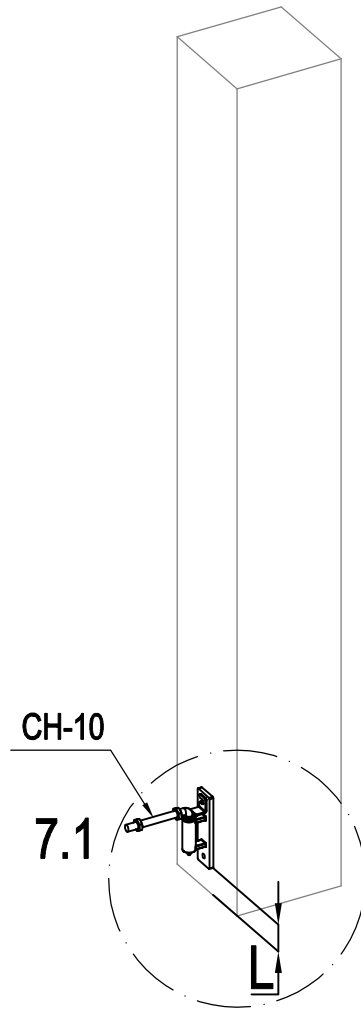

	Dr-20	1
	Dr-21	1
	Dr-22	1
	Dr-25	1

	Dr-18	1
	Dr-19	1
	Dr-25a	2
	Dr-27	2

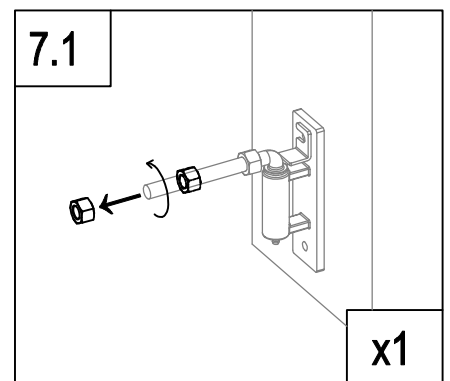
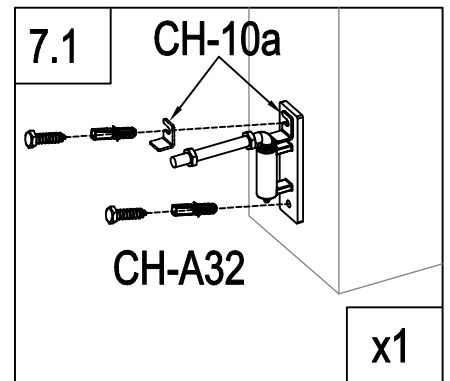
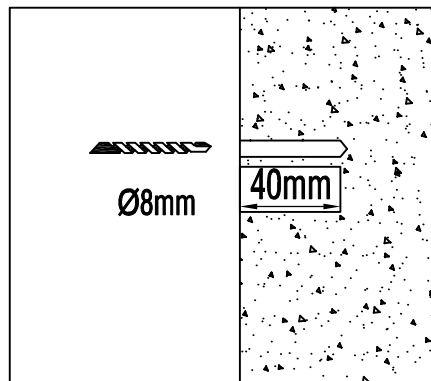
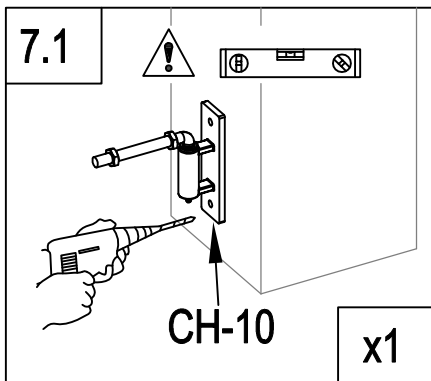



 **L > 35mm**

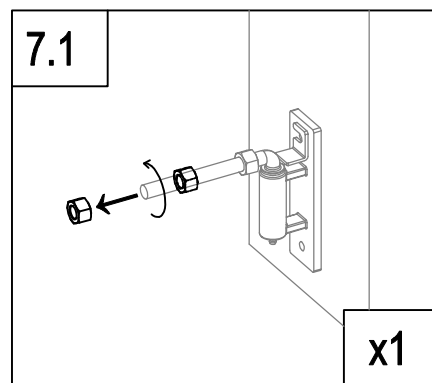
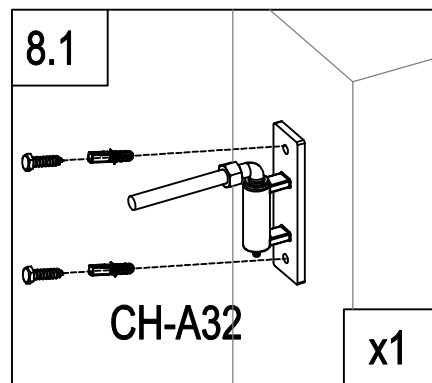
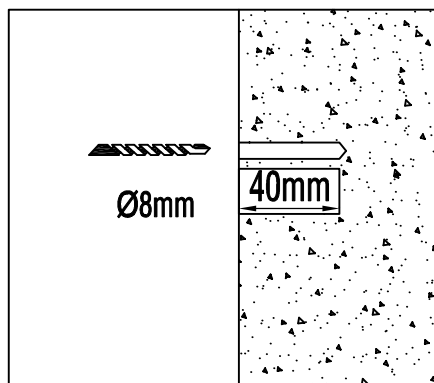
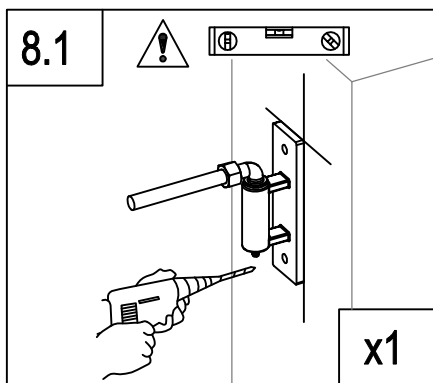
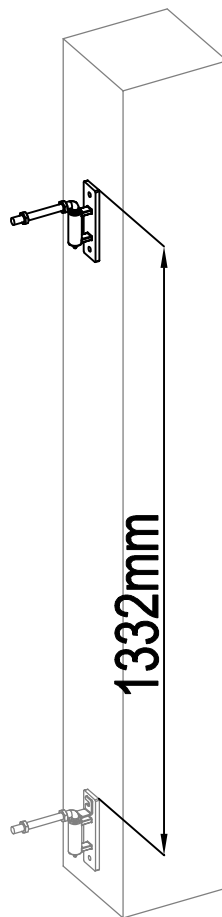

	CH-10	1
	CH-10a	1
	CH-A32	2



	CH-10	1
	CH-A32	2

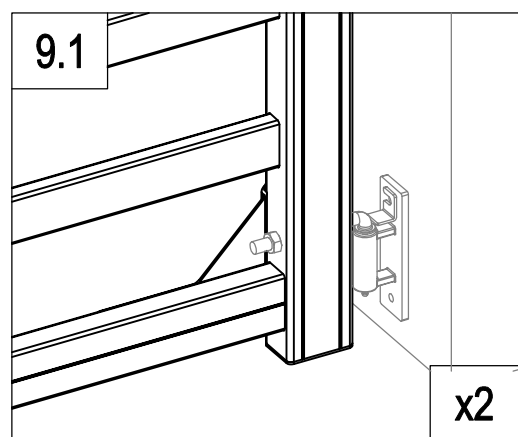
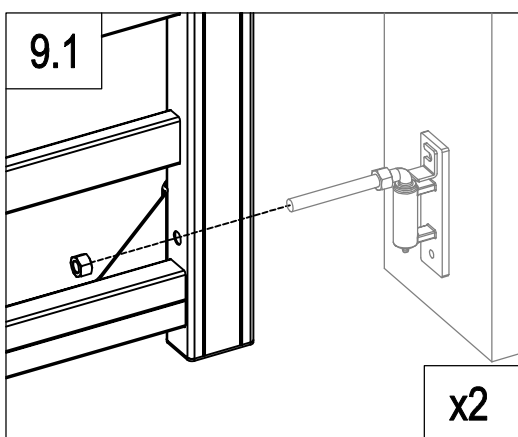
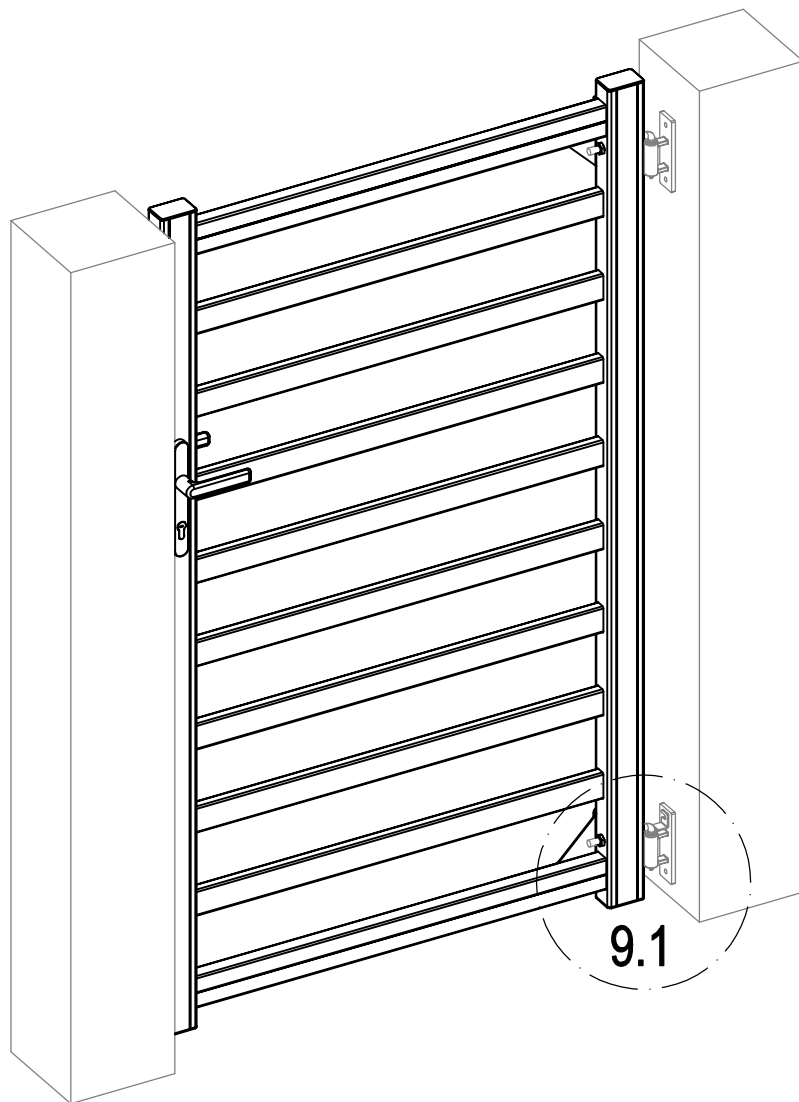

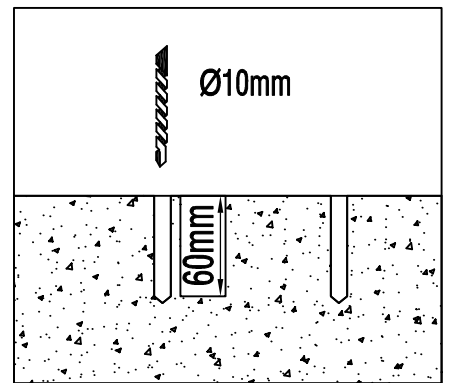
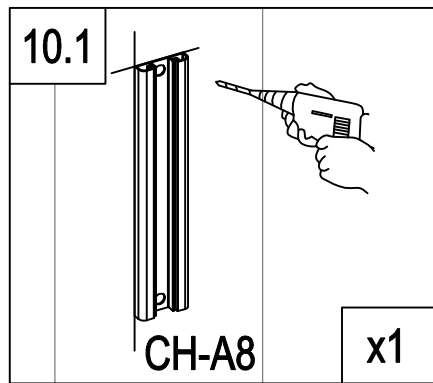
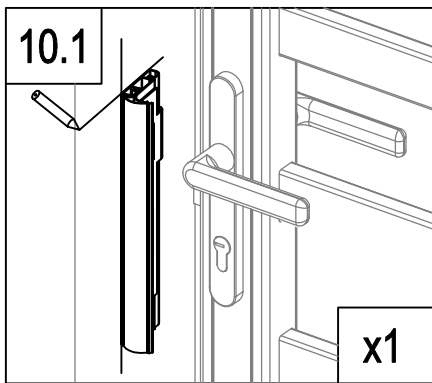
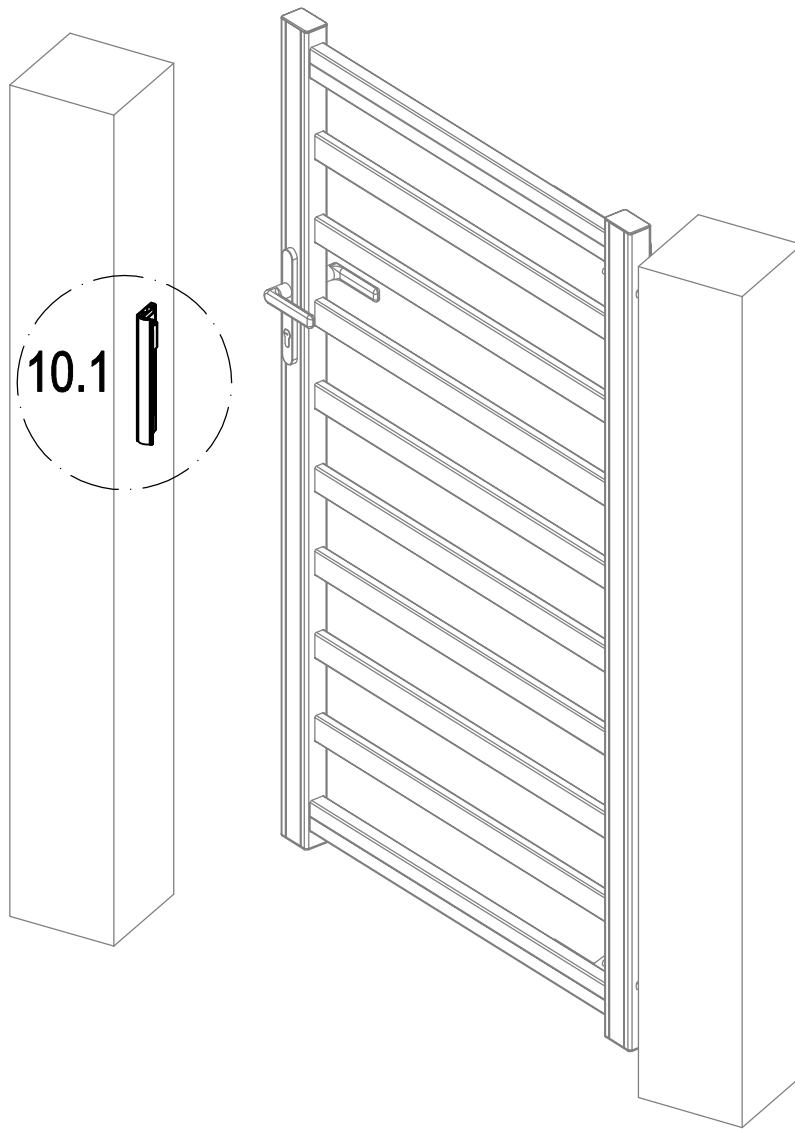



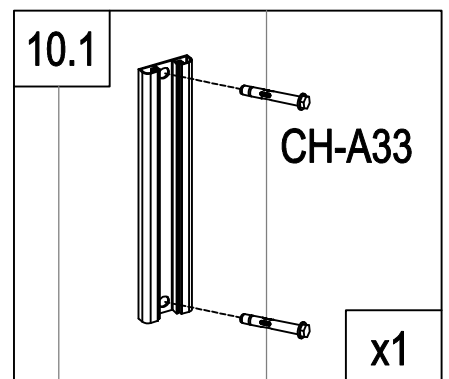

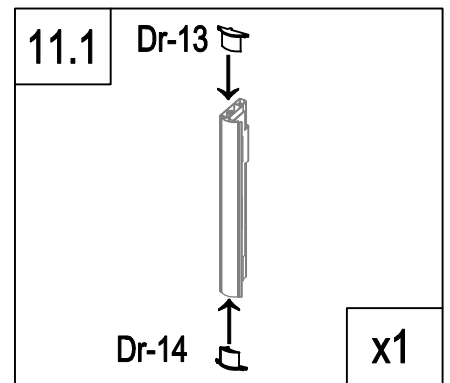
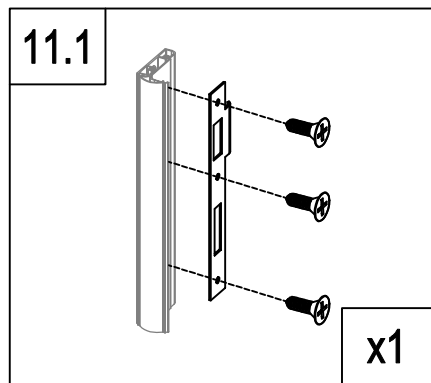
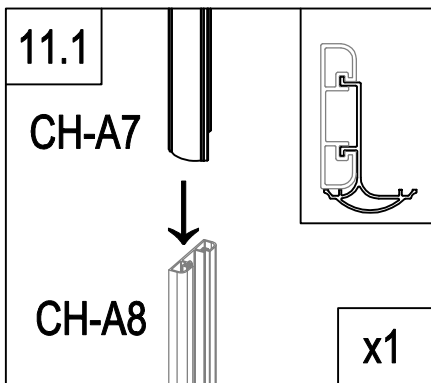
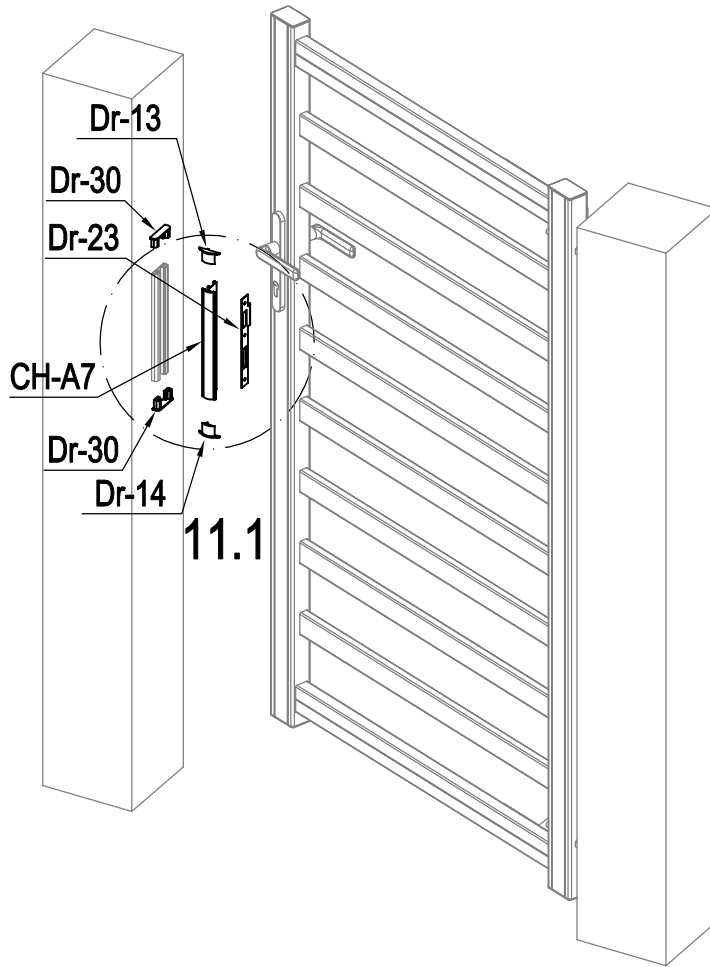
	CH-A8	2
	CH-A7	1
	Dr-23	1
	CH-A33	2





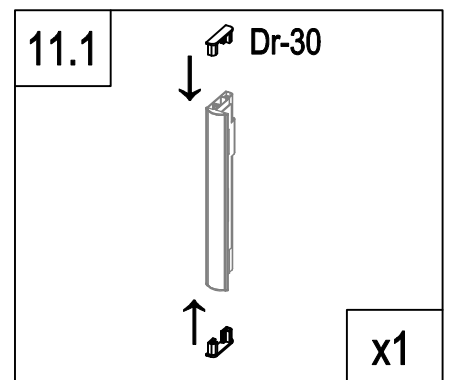

	Dr-13	1
	Dr-14	1
	Dr-30	2
	Dr-26	3

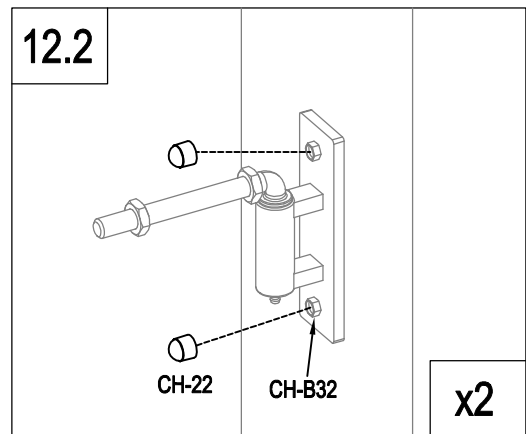
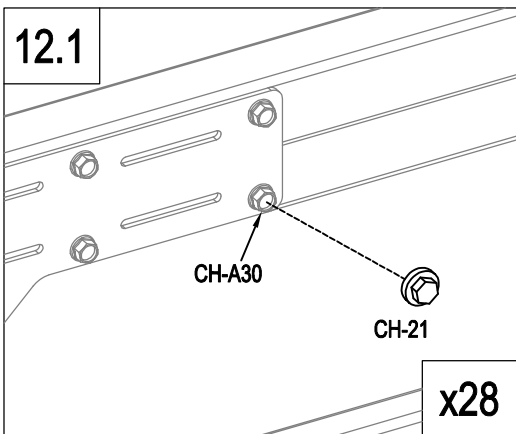
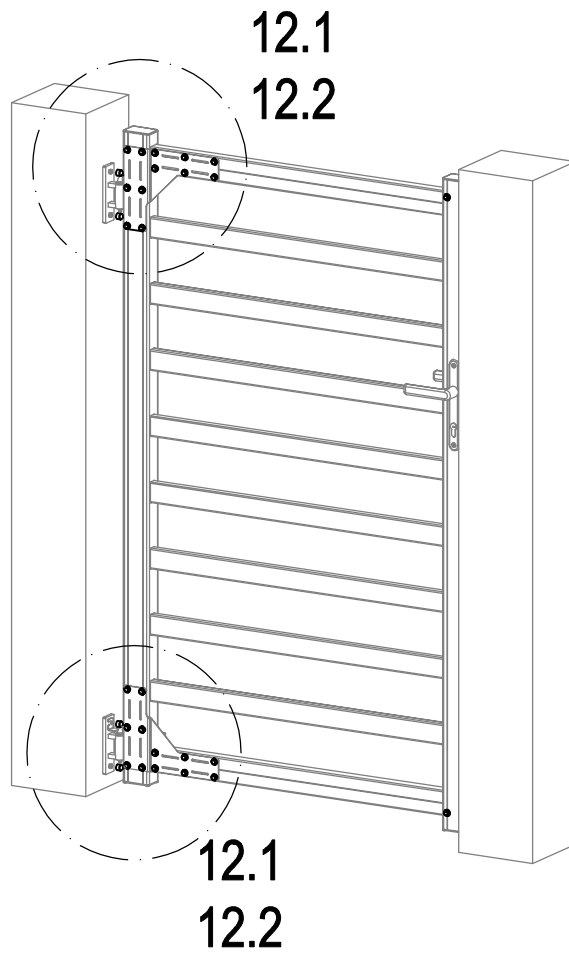



	CH-21	28
	CH-22	4