



BEFORE THE FIRST USING YOUR ELECTRIC STORAGE WATER HEATER, CAREFULLY READ THIS OPERATION MANUAL

DEAR CUSTOMER!

Congratulations on your purchase of an electric water heater THERMEX.

Water heaters THERMEX are designed and manufactured in strict accordance with domestic and international standards guaranteeing operation reliability and safety.

Present manual applies to THERMEX models of Mara Pro. The full name of the model of your heater is specified in "Manufacturer's warranty" section (sub-section "Note of sale") and in the marking plate on the heater casing.

1. APPLICATION

Electric water heater (hereinafter referred to as the EWH) is designed to provide with hot water for domestic and industrial facilities having a cold water supply line pressure of not less than 0.05 MPa and not more than 0.8 MPa.

EWH shall be operated indoors in heated spaces and it is not designed for operation in continuous flow mode.

2. SCOPE OF SUPPLY

Water heater	- 1 pcs.
Safety valve of GP type	- 1 pcs.
Operation manual	- 1 pcs.
Installation kit	- 1 set
Packaging	- 1 pcs.

3. MAIN TECHNICAL CHARACTERISTICS

EWH power supply shall be within the range of 220-240 V. Supply network frequency 50/60 Hz \pm 1%. Volume of the inner tank and heating element power are specified in the marking plate on the casing. Thread diameter in water inlet and outlet pipes - G1/2 ".

The manufacturer reserves the right to make changes to the design, complete set and specifications of the heater without prior notice.

Model	Code	Average heating time $\Delta T = 45^{\circ} \text{C}$ at 1.5 kW	Installation
Mara 30 (pro)	111 408	1 h 06 min.	vertical / horizontal

Model	Code	Average heating time $\Delta T = 45^{\circ} \text{C}$ at 2.0 kW	Installation
Mara 50 (pro)	111 409	1 h 23 min.	vertical / horizontal
Mara 80 (pro)	111 410	2 h 13 min.	vertical / horizontal
Mara 100 (pro)	111 411	2 h 46 min.	vertical / horizontal

4. DESCRIPTION AND PRINCIPLE OF OPERATION

The outside casing of the EWH is made of steel. Inner tanks have a special bio-glass-porcelain coating reliably protecting the inner surface against chemical corrosion. The space between the outside casing and the inner tank is filled with polyurethane foam - a modern, ecologically clean thermal insulation, which has the best heat-saving characteristics. Mara Pro models have two screwed nozzles: for inlet of cold water (Fig. 1, p. 3) with a blue ring and for outlet of hot water (Fig. 1, p. 2) — with a red ring. The control panel, in all models, is on the front side of the EWH. (Fig. 1, p.16).

Dry heating element (DHE), thermostat and thermal switch sensors are mounted on the removable flange. DHE is used to heat water and thermostat provides with possibility of heating temperature regulation up to $+75^{\circ}\text{C}$.

Safety valve (Fig. 1, p. 5) operates as the check valve, ensuring protection of the water ingress from the water heater into the sewage system in case of pressure drop in the sewage system and in case of pressure rise in the tank at high water heating, as well as the functions of the safety valve, releasing overpressure in the tank at high water heating. During water heater operation water may leak out of the exhaust outlet pipe of the safety valve to relieve excessive pressure, which is made for the purpose of water heater safety. This outlet pipe shall remain open to the atmosphere and be installed constantly down.

Drainage of water from the safety valve exhaust pipe into the drain shall be provided with installation of the corresponding EWH drainage.

It is required regularly (at least once a month) to discharge a small amount of water through the exhaust pipe of the safety valve into the drain to remove lime deposits and to test the operating functionality of the valve. Handle (Fig. 1, p. 15) is intended to open the valve. It is necessary to control when operating water heater this handle to be in position closing water draining from the tank.

5. SPECIFYING SECURITY MEASURES

Electrical safety and corrosion protection of EWH are guaranteed only if there is an effective grounding in accordance with applicable electric installation rules and regulations.

Plumbing pipes and fittings shall conform to parameters of water main and have the required certificates of quality.

When installing and operating EWH the following is not allowed:

- To power EWH if EWH is not filled with water.
- To remove the protective cover when the power is on.
- Use EWH without grounding or use water pipes as grounding.
- To connect EWH to water supply with pressure exceeding 0.8 MPa.
- To connect EWH to the water supply without safety valve.
- To drain water from EWH with power switched on.
- To use spare parts not recommended by the manufacturer.
- To use water from the EWH for cooking.
- To use water containing impurities (sand, small stones), which might lead to EWH and safety valve breakdown.
- To modify design and installation dimensions of EWH brackets.

Ambient temperature shall be within the range of 5°C to 40°C. Water in freezing EWH at negative temperatures results in malfunction, which is not a warranty case.



Attention should be paid to children so that they do not play with EWH. EWH is not intended for use by persons (including children) with limited physical, sensory or mental capabilities, or by persons who do not know how to use the EWH, except for cases when this happens under the supervision or instructions by persons responsible for safety of the EWH.

During EWH operation, it shall be inspected regularly for proper health (absence of dripping, burning smell, wiring sparks, etc.). In the case of long interruptions in water heater operation, water supply failures, EWH shall be disabled and cold water inlet valve shall be shut off.

6. INSTALLATION AND CONNECTION

All installation, plumbing and electrical works shall be performed by qualified personnel.

7. ARRANGEMENT AND INSTALLATION

All installation, plumbing and electrical works shall be performed by qualified personnel.

EWH installation shall be performed in accordance with marking on the housing.

It is recommended to install EWH as close as possible to the place of hot water using to reduce heat loss in the pipes.

When choosing the place of installation it should be taken into account the total weight of EWH filled with water. Walls and floor with low carrying capacity should be strengthened accordingly. When drilling (making) holes in the wall consider cables, ducts and pipes in the wall.

EWH is suspended by brackets on hook anchors fixed in the wall. Hooks mounting on the wall shall exclude spontaneous movement of EWH brackets along them.

The manufacturer bears no liability for EWH falling associated with improper installation of anchors and their selection.

For EWH maintenance the distance from the protective cover to the nearest surface in the direction of the removable flange axis shall be at least 30 cm for all models.



In order to avoid damage of the user's and/or third parties' property in the event of a faulty hot water system, it is required to install EWH in spaces with waterproofing and drainage to the sewers, and in no case to place under items exposed to the water under EWH. When placed in unprotected areas a protective plate (not supplied) with drainage into sewers shall be installed under the EWH.

In case of placing EWH in hard-to-reach places in order to perform maintenance and warranty service (mezzanine floors, niches, ceiling voids, etc.), installation and dismantling of EWH is carried out by the user on his own or for his own account.

Note: safety tray is not included into the scope of EWH supply.

8. CONNECTION TO WATER MAINS

Cold water shall be supplied to EWH using pre-filter with water treatment level not less than 200 μm .

Install pressure relief valve (Fig. 1, p.5) at the cold water inlet (Fig. 1, p. 3) tube with the blue ring, by 3.5-4 turnings, ensuring junction tightness with any sealing material (flax, FUM tape, etc.).

During EWH operation you can observe water leak out of the outlet pipe of the safety valve for excessive pressure release to ensure safety of the water heater. It is recommended to connect to a drainage hole a rubber or silicone pipe of the relevant diameter for moisture removal.

Connection to the water supply line shall be carried out in accordance with Fig. 1 using copper, plastic pipes or special flexible sanitary wiring. Do not use any used flexible wiring. It is recommended to supply water to EWH through filter installed on the cold water main (not included in the scope of supply).



Do not use used flexible feed pipes. Do not operate the EWH without safety valve or with valve made by other manufacturers.

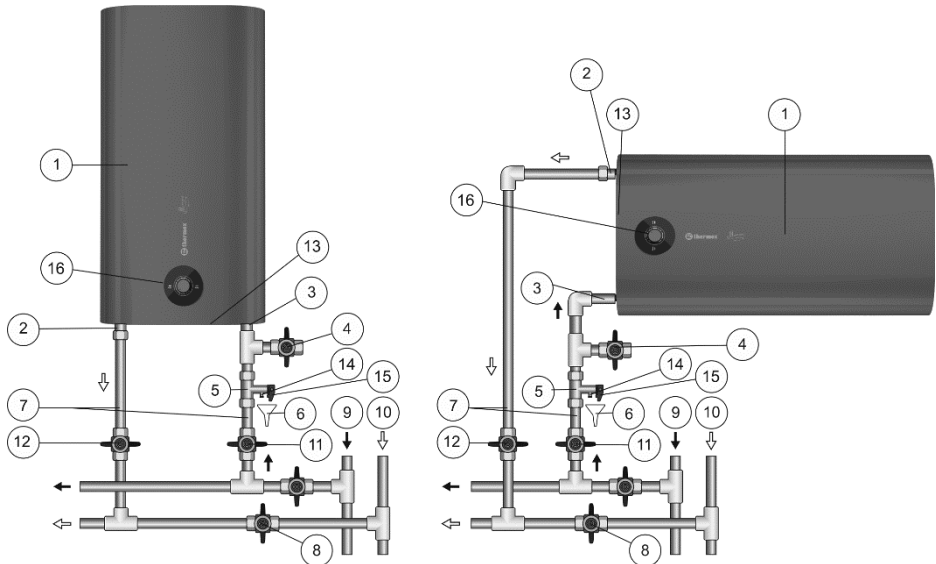

Figure 1. EWH connection diagram to water supply

Figure 1: 1 – EWH, 2 – hot water pipe, 3 – cold water pipe, 4 – drain valve (not in the scope of supply), 5 – safety valve, 6 – drainage (not in the scope of supply), 7 – feed pipe, 8 – shut off valve when EWH operation, 9 – cold water main, 10 – hot water main, 11 – cold water shut-off valve, 12 – hot water shut-off valve, 13 – protective cover, 14 – exhaust pipe of the safety valve, 15 – handle for opening pressure relief valve, 16 – control panel.

After connecting EWH make sure that cold water shut-off valve is open and hot water shut-off valve (Fig. 1, p. 8) is closed. Open cold water tap in EWH (Fig. 1, p. 11), hot water outlet valve (Fig. 1, p. 12) and hot water tap on mixer to ensure outflow of air from the EWH. When the final EWH filling, water will continuously flow out of mixer tap. When connecting EWH in places not provided with water supply it is permitted to supply water in EWH from auxiliary tank using pumping station, or from reservoir placed at a height of not less than 5 meters over the top of EWH.

Note: for ease of maintenance during EWH operation it is recommended to install drain valve (Fig. 1, p. 4) in accordance with Fig. 1 (for models not equipped with drain-pipe (not in the scope of EWH supply)).

If the water pressure exceeds 0.8 MPa, at EWH cold water inlet, before the safety valve (in the direction of water flow), the appropriate pressure reducing valve (not supplied with the EWH) shall be installed to reduce water pressure to standard.

9. CONNECTION TO POWER SUPPLY

Prior to the water heater connection to electrical network, make sure its parameters complies with the technical specifications of the water heater.

ATTENTION! Prior to power activation make sure EWH is filled with water!

Water heater shall be earthed to ensure safe operation. EWH is equipped with the stationary power cable (option) with Europlug (option). Power outlet shall have an earth terminal with the connected earthing wire and located in the area protected from moisture, or comply with the requirements not less than IPX4.

10. OPERATION

The EWH is switched on/off by turning the indicator line on the control knob located on the protective cover of the water heater (Fig. 1, p. 16) to the "OFF" zone. The water temperature in the inner tank is adjusted using the control knob (Fig. 1, p. 16) in the range of values from "OFF" (minimum values) to "HIGH" (maximum values). The control indicator lamp displays the operating mode of the EWH - it glows when the water is heated and goes out when the set temperature is reached.

11. TECHNICAL MAINTENANCE

When performing maintenance scale on DHE is checked. At the same time residue that may accumulate in the bottom of the EWH is removed. If there is scale on THE, it can be removed by using scale removing means or mechanically. It is recommended to hold the first technical maintenance after a year from the time of connection by experts of a specialized organization and depending on intensity of scale and residue to determine intervals of follow-up maintenance. This action will extend the maximum EWH service life.

The first replacement of the magnesium anode shall be made no later than 12 months from the date of EWH installation. In case of no mark of installation in warranty certificate with the seal of installation company, the period is calculated from the date of purchase. Regular periodic maintenance and annual replacement of the magnesium anode in time is imperative to maintain the manufacturer's warranty. Replacement of the anode must be accompanied by a mark in the warranty card in case of replacement by a service organization, or an attached sales receipt for its purchase in case of replacement by the owner.



ATTENTION: accumulation of scale on DHE may cause its damage .

Note: Damages to DHE due to scale formation are not subject to warranty. Regular maintenance is not included in the warranty of the manufacturer and the seller.

The following shall be carried out for maintenance:

- Turn off EWH power;
- Cool hot water or discharge it through the mixer;
- Cut off supply of cold water into EWH;
- Unscrew the relief valve or open drain valve;
- To put on the cold water supply inlet or discharge valve a rubber hose, sending the other end down the drain;
- Open hot water tap on mixer and drain water from the EWH through the hose;
- Remove the protective cover, disconnect wires, unscrew and remove from the casing the removable flange;
- Clean if necessary DHEs from scale and remove residue from the tank;
- Assemble, fill the EWH with water and power on.

In models with drain pipe, it is enough to cut off the flow of cold water into the EWH, unscrew the drain stub on drain pipe and open hot water tap. Once the water is discharged, you can open for a while cold water supply in EWH for additional tank washing.

When conducting EWH maintenance by forces of specialized organization mark with the seal of organization performing maintenance shall be made in service coupon.

12. POSSIBLE FAULTS AND REMEDIES.

Malfunction	Possible cause	How to fix
Hot water pressure from EWH decreased. Cold water pressure keeps at the level.	Clogged inlet safety valve	Remove the valve and clean it in water
Heating time increased	DHE is covered with a layer of sludge	Remove the flange and clean the DHE
	Supply voltage decreased	Contact power main operation service
Frequent tripping of thermal switch	The set temperature is close to the limit	Set lower value of water heating temperature

	Thermostat tube is covered with sludge	Take out the EWH the removable flange and gently clean the tube from scale
EWH operates but is not heating water	Valve (Fig. 1, p. 8) is not closed or out of order	Close or replace the valve (Fig. 1, p. 8)
Powered EWH does not heat water. No backlights of indicator lamps.	<ol style="list-style-type: none"> 1) No voltage in electric network; 2) Damaged power cord; 3) Thermal switch actuated and not switched on. 	<ol style="list-style-type: none"> 1) Check voltage at the electrical outlet; 2) Contact a qualified service center; 3) Disconnect from the power supply, remove EWH protective cover, press the button on thermal switch until you hear a click install the cover and turn on the power.

These faults are not defects of EWH and shall be fixed by the consumer or by a specialized organization at his own expense.

In case of failure to fix problems using the above recommendations or in case of others problems revealing you should contact the authorized service center listed in the operation manual.

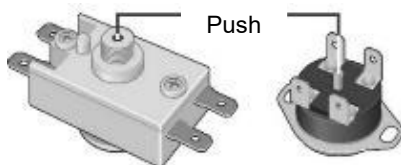

Figure 2. Thermal switch arrangement diagram

13. TRANSPORTATION AND STORAGE OF ELECTRIC WATER HEATERS

Transportation and storage of electric water heaters shall be carried out in accordance with manipulation marks on the packaging:



- need to protect the goods from moisture



- fragile, delicate handling



- recommended storage temperature range from +5° to +40° C



- correct vertical position of cargo;

14. DISPOSAL

When complying with the rules of EWH installation, operation and maintenance and when water quality complying with current standard the manufacturer sets EWH lifespan of 9 years from the date of purchase.

All parts of the heater are made of materials allowing, where appropriate, environmentally sound disposal which must be made in accordance with the rules and regulations of the country where the water heater is operated.

When disposing of the EWH comply with local environmental laws and guidelines.

The manufacturer reserves the right to make changes to the design and specifications of the heater without prior notice.

15. MANUFACTURER'S WARRANTY

The manufacturer sets 2 years as the period of warranty for water heater, and warranty period for parts and components is as follows:

- for water containing tank (inner tank) – 5 years;
- for other components (heating element, thermostat, indicator lights, gaskets, temperature indicator, pressure relief valve) - 2 years.

The warranty period is calculated from the date of EWH sale. If there is no or corrected date of sale and shop stamp, the warranty period is calculated from the date of EWH manufacture. Claims within the warranty period are accepted only on presentation of the warranty card with marks of the seller, and the identification plate on the casing of the EWH. Release date of a water heater is encoded in a unique serial number, located on the identification plate on the casing. EWH serial number consists of thirteen

digits. The third and fourth digits of the serial number are year of manufacture, the fifth and sixth digits - month of release, the seventh and eighth digits - day of EWH release. Claims within the warranty period are accepted only on presentation of the guarantee card with marks of the seller, and the identification plate on the casing of the EWH.

The warranty shall apply to EWH only. Responsibility for compliance with principles of installation and connection shall be borne by the buyer (in case of connection by his own) or by the installer carrying out connection.

The first replacement of the magnesium anode shall be made no later than 12 months from the date of EWH installation. In case of no mark of installation in warranty certificate with the seal of installation company, the period is calculated from the date of purchase. Regular periodic maintenance and annual replacement of the magnesium anode in time is imperative to maintain the manufacturer's warranty. Replacement of the anode must be accompanied by a mark in the warranty card in case of replacement by a service organization, or an attached sales receipt for its purchase in case of replacement by the owner.

The manufacturer shall not be liable for defects due to violations of principles of installation, operation and maintenance of EWH set forth herein, including in cases where these defects have arisen due to invalid parameters of mains (electricity and water), where EWH is operated, and due to the intervention of a third party. Manufacturer's warranty does not cover claims for appearance of EWH.

16. INFORMATION ON THE MANUFACTURER

Manufacturer:

AnHui Weber New Energy Water Heating System Equipments Co., Ltd.

No. 500 YinHuangXi Road, Ma'anshan economic and Technological Development Zone, Anhui, China

All models have been certified and comply with requirements of European Directives: 2014/35/EU, 2014/30/EU and 2011/65/EU (RoHS).



NOTE OF SALE

Model _____ Serial No. _____

Date of sale _____, 20 ____ .

Dealer: _____

Dealer's representative signature _____



The product is completed; I have no claims for the appearance of the product. Operation manual with the necessary marks is received. I have read, understood and accepted operation rules and warranty terms.

Customer's signature: _____



WARRANTY CERTIFICATE 1

Model		Dealer's seal
Serial No.		
Date of sale		
Dealer		

To be filled by the dealer



WARRANTY CERTIFICATE 2

Model		Dealer's seal
Serial No.		
Date of sale		
Dealer		

To be filled by the dealer

Date of acceptance		Stamp of service center
Issue date		
Defect		
Executed work		
Expert (full name)		

Filled in by service center

Date of acceptance		Stamp of service center
Issue date		
Defect		
Executed work		
Expert (full name)		

Filled in by service center



WARRANTY CERTIFICATE 3

Model		Dealer's seal
Serial No.		
Date of sale		
Dealer		

To be filled by the dealer



WARRANTY CERTIFICATE 4

Model		Dealer's seal
Serial No.		
Date of sale		
Dealer		

To be filled by the dealer

Date of acceptance		Stamp of service center
Issue date		
Defect		
Executed work		
Expert (full name)		

Filled in by service center

Date of acceptance		Stamp of service center
Issue date		
Defect		
Executed work		
Expert (full name)		

Filled in by service center